



**Receiver  
With HAC & waterproof  
8x15x1.5 mm**

**BR815S15YN32WP**

**Revision**

<b>Date</b>	<b>Version</b>	<b>Status</b>	<b>Changes</b>	<b>Approver</b>
2019/6/13	V0.1	Draft	First release	AX
2019/6/26	V0.2	Draft	Add waterproof testing description and update marking rules	AX
2020/8/5	V2.0	Draft	Update Membrane material Update F0	AX
2020/8/11	V2.1	Draft	Update RMS & amp and THD curve limit	AX

# 1. Mechanical Characteristics

## 1.1. Main Dimensions

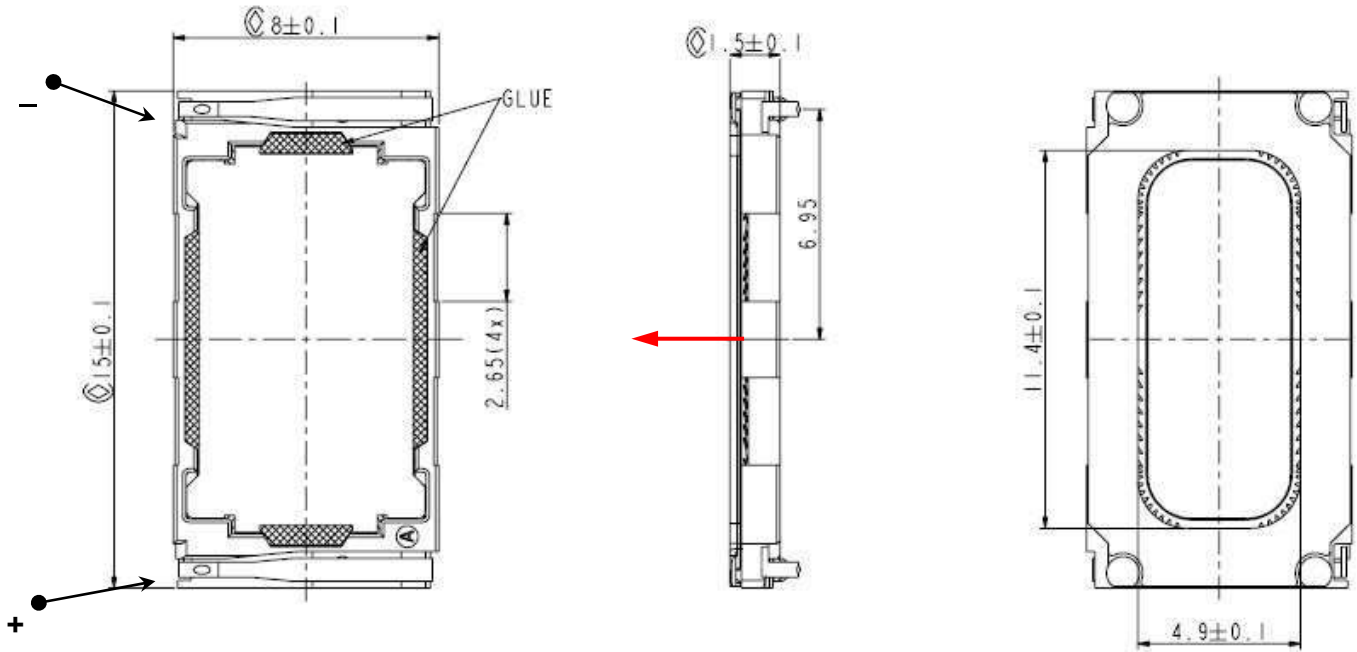

Positive voltage on pin '+' moves membrane in direction of red arrow!

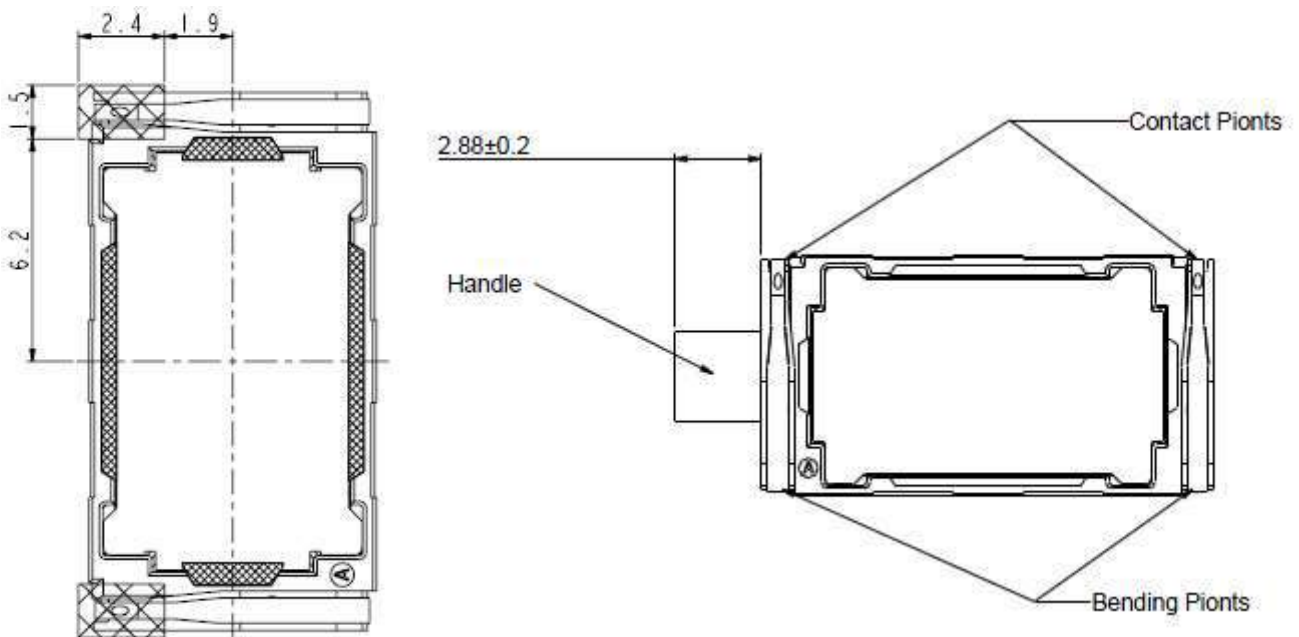

Recommend PAD layout

The Mesh Handle Direction

### 1.2. Spring Force

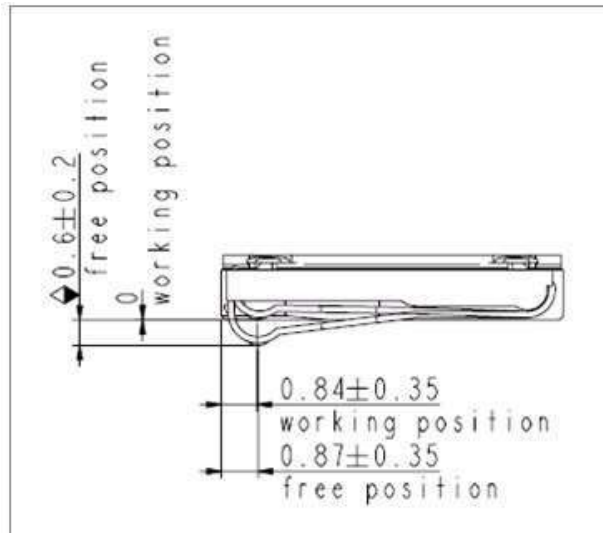
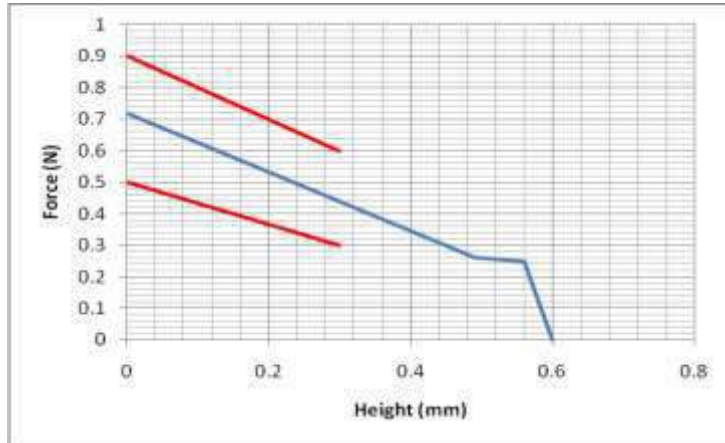

### 1.3. Part Marking/Labeling

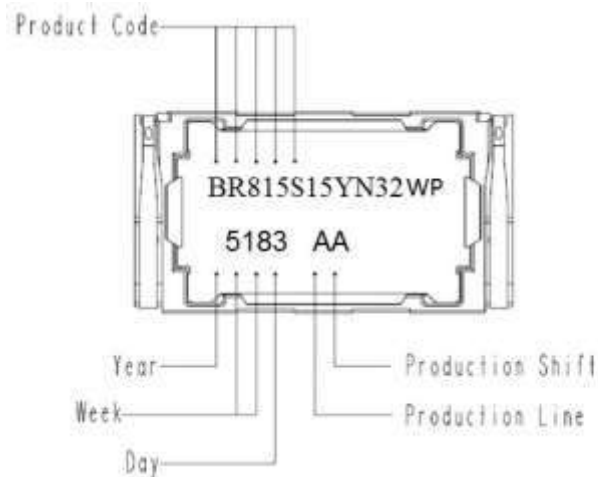

## 1.4. Forces on Component

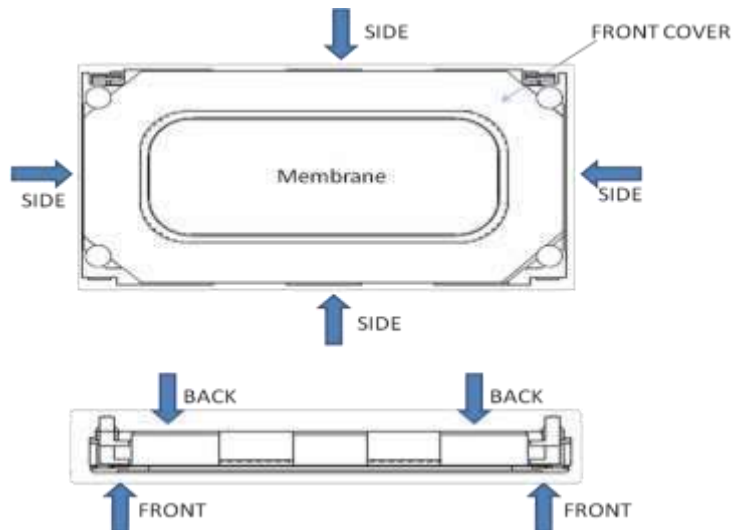

State	Maximum Permanent Force[N]	Maximum Handling Force[N]
From Back To Front(cover)	10	15
Membrane	0	0
From Side to Side	5	10

## 1.5. Material List

1. MATERIAL of BASKET: PC
2. MATERIAL of MEMBRANE: PEEK+PU
3. MATERIAL of POT/ TOPPLATE: SOFT MAGNETIC IRON, Ni Plating
4. MATERIAL of MAGNET: Nd Fe B
5. MATERIAL of SPRING CONTACT: STAINLESS STEEL
6. PLATING of SPRING CONTACT: 1-3  $\mu\text{m}$  Ni, 0.5 $\mu\text{m}$  minimum Au (CONTACT POINT)
7. MATERIAL of COVER: Brass CuZn, Ni Plating
8. DIMENSION: 8x15x1.5mm
9. MASS: 0.554 g
- 10.CONNECTIONS: SPRING CONTACT
- 11.DIRECTION of CONNECTOR: VERTICAL TO PCB (ORIENTATED)

### 1.6. Waterproof parameter

Waterproof level IPX7  
 100% inspected via air leaking testing process and equipment

## 2. Electro-Acoustic Characteristics

### 2.1. Baffle

Typical frequency response measured according to chapter 2.6

(Baffle 1cm distance at 566mVrms)

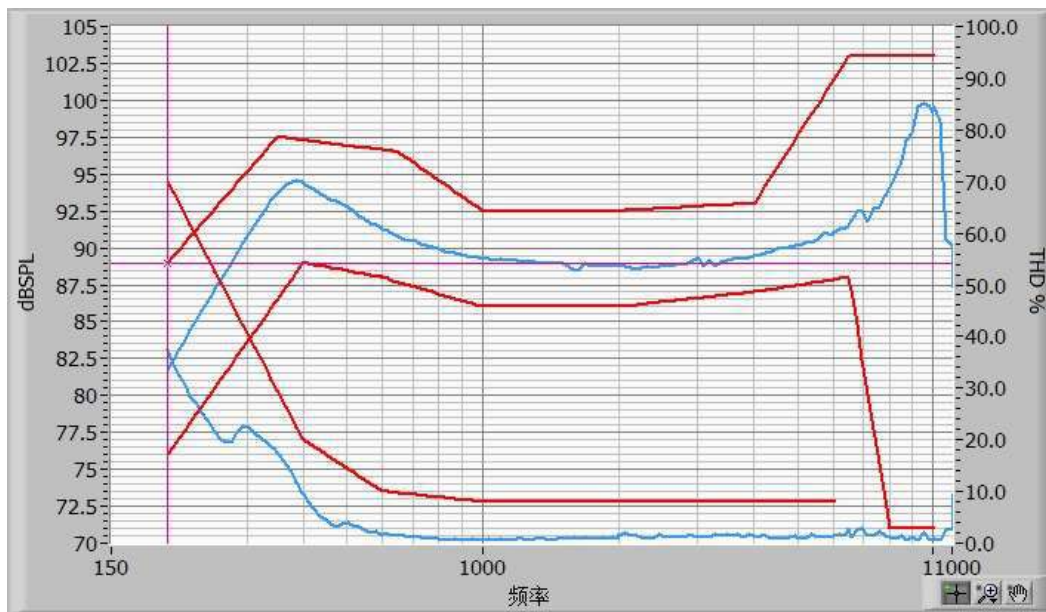

f(Hz)	SPL lower limit(dB)	f(Hz)	SPL upper limit(dB)	f(Hz)	THD upper limit(%)
200	76	200	89	200	70
400	89	350	97.5	400	20
600	88	650	96.5	600	10
1000	86	1000	92.5	1000	8
2000	86	2000	92.5	6000	8
4000	87	4000	93		
6500	88	6500	103		
8000	71	10000	103		
10000	71				

## 2.2. Electro-Acoustic Parameters

Receiver mounted in baffle acc. to chapter 2.6 and 3.2 high leak ear acc. to chapter 2.7

1. Rated impedance	Z:	32Ω
2. Voice coil resistance	R:	28.8Ω±2.88Ω
3. Resonance frequency	f <sub>0</sub> :	350Hz±35Hz
4. Maximum diaphragm excursion above the top of the surface:		0.2mm
5. Nominal characteristic sensitivity(@3.2 high leak; 1KHz, 10mW)		25.5±2.5 dBPa/V
6. Nominal characteristic sensitivity (@baffle, 10mW, 1cm; average from 1KHz to 3KHz)		89 dBPa re 20uPa
7. THD		according to chapter 2.2

## 2.3. Power Handling

Receiver mounted in lifetime test device (open rear/open front).

1. RATED NOISE POWER (500h, pink noise with the weighting, crest factor is 12dB)	10mW (RMS)
---	------------

Type	Order	F0[Hz]
High Pass	1	250
High Pass	10	100
Low Pass	10	3500

2. OVERLOAD POWER (50h, sinusoidal, 200Hz~6 KHz, allow increase R&B)	30mW (RMS)
---	------------

3. RATED SINUSOIDAL POWER (50h, sinusoidal, 200Hz~6 KHz, no damage)	10mW (RMS)
--	------------

## 2.4. Magnetic field for Hearing Aid characteristics

RECEIVER MOUNTED IN MEASUREMENT SETUP ACC. TO Chapter 2.9

1. CHARACT. FIELD STRENGTH SENSITIVITY  
at 566mV (10mW) 1kHz, measurement plane 15mm  
Axial : 12.13 dB A/m per V  
Radial (Average of 4 Position): 4.50 dB A/m per V
2. FREQUENCY RESPONSE (AXIAL relative to value at 1kHz)

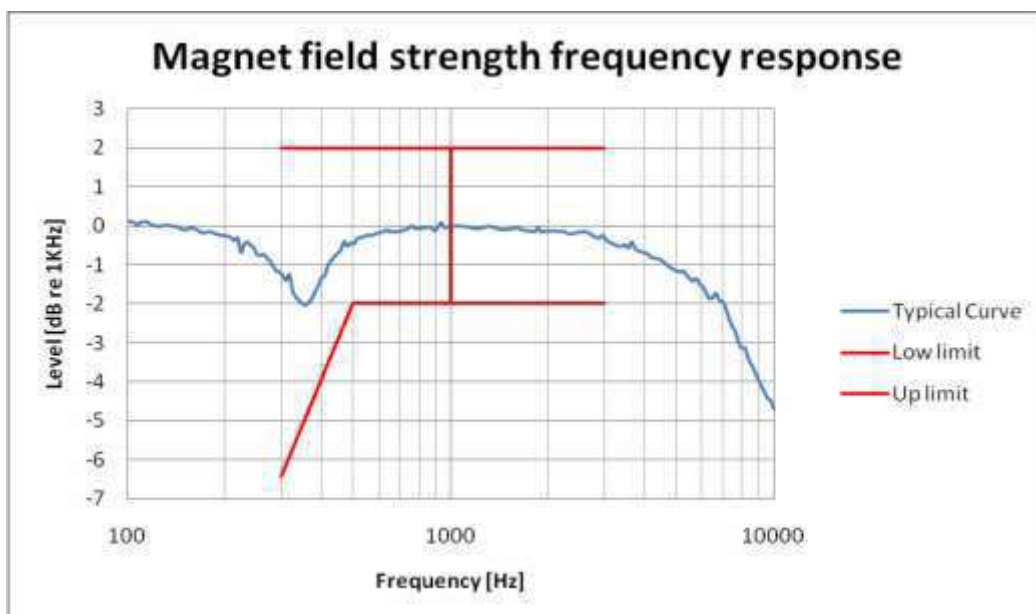

## 2.5. Measurement setup on baffle

### 2.5.1. Measured setup

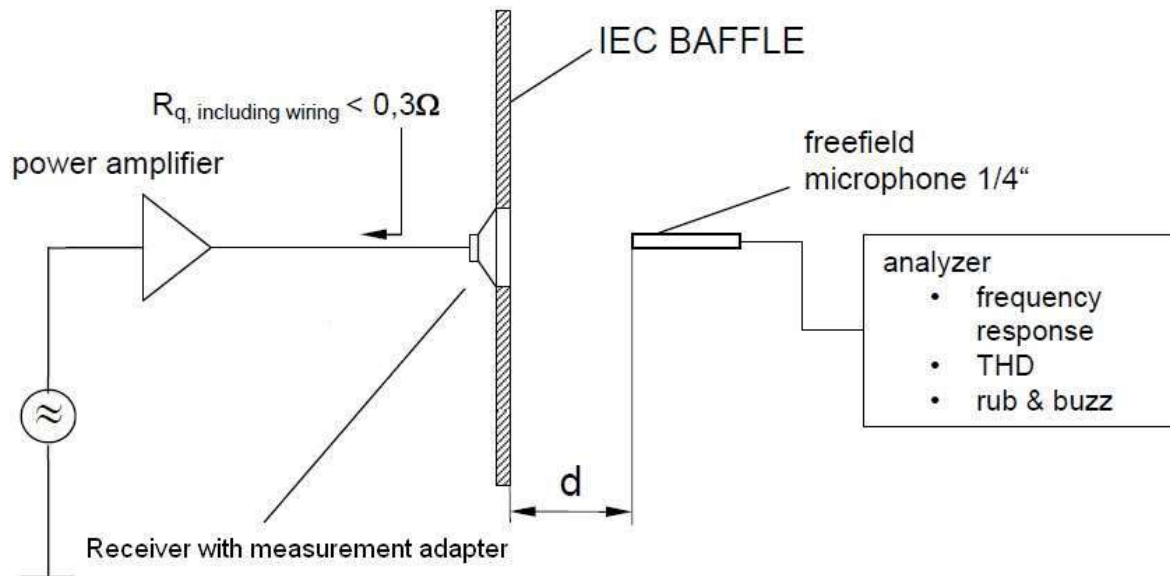

$D=1.0\text{cm.}$



2.5.2. Measured adapter

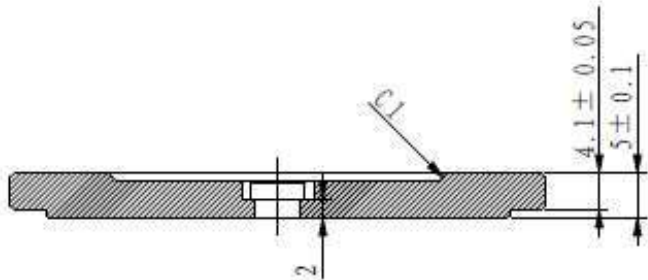

SECTION A-A

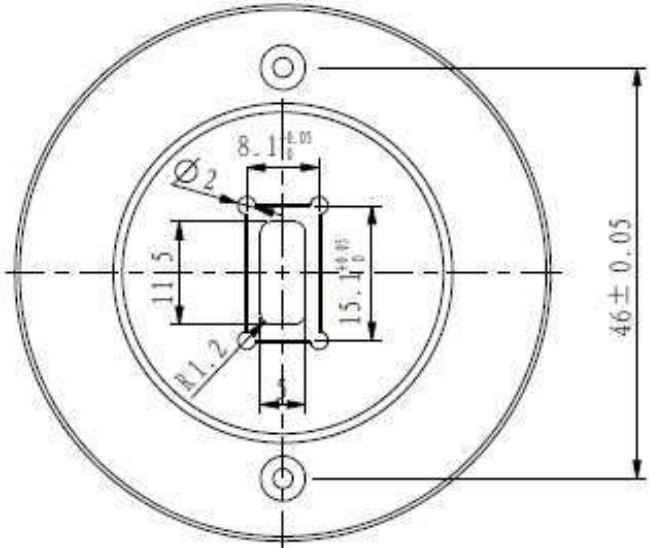

## 2.6. Measurement setup on BK 3.2 high leak

### 2.6.1. Measured setup

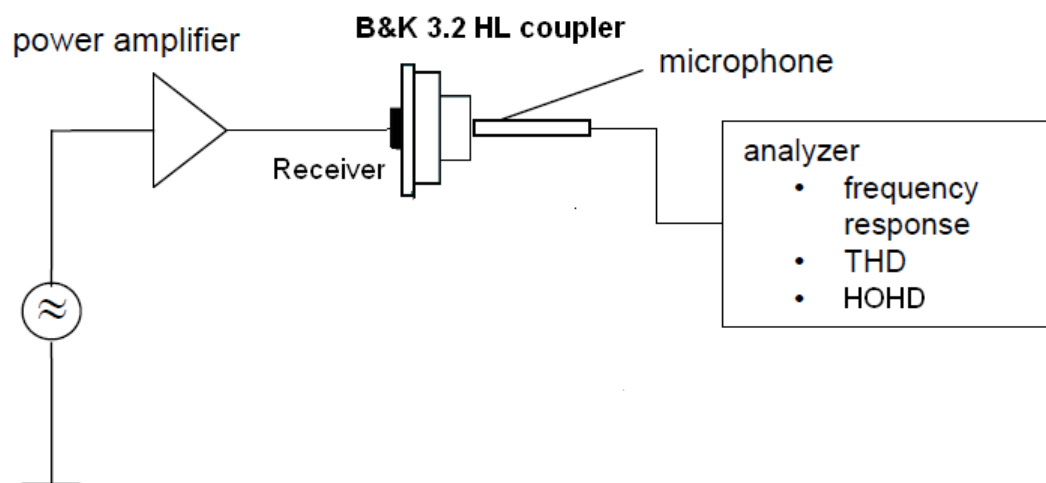

2.6.2. Measured adapter

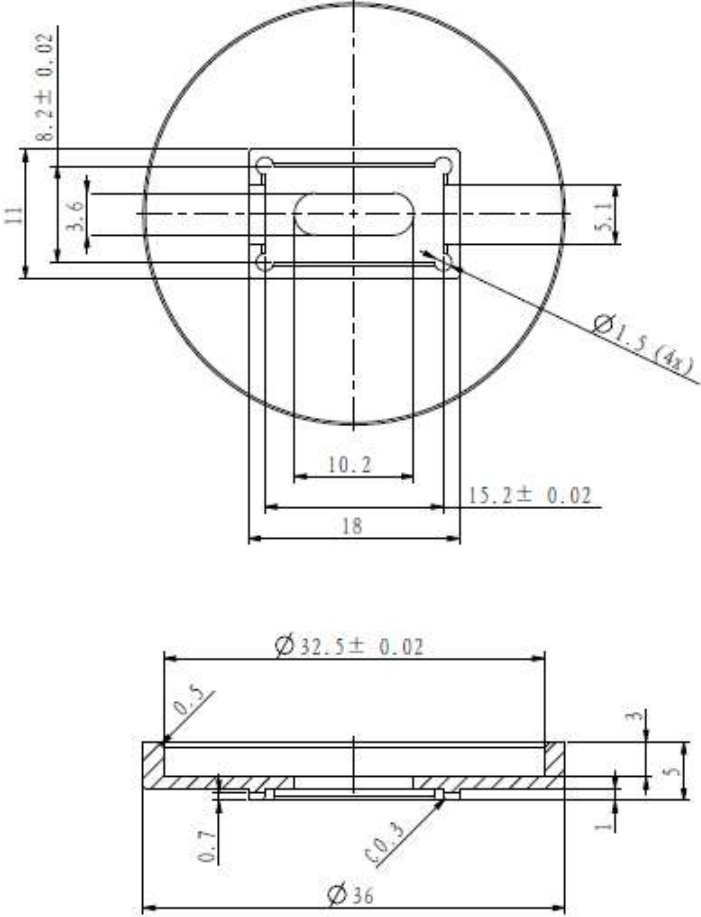

## 2.7. Measured Parameters

### 1. Measure Setup

For the test on baffle, the test signal is cosine log sweep signal, from 10KHz to 100 Hz, 160 steps, used BK 4939 1/4" free field microphone, sn is 2624669.

For the test on BK3.2 high leak, the test signal is cosine log sweep signal, from 10KHz to 100 Hz, 160 steps, used BK 4195 Ear Simulator, sn is 2538591.

### 2. Sensitivity

Sensitivity is expressed in dB rel 1V/1Pa measured at input voltage of 0.566V using the measurement setup according chapter 2.7.

### 3. Frequency response

Frequency response on baffle is measured according to the test setup in chapter 2.6 at input voltage of 0.566V and checked against the tolerance window defined in chapter 2.1.

Frequency response on BK3.2 high leak is measured according to the test setup in chapter 2.7 at input voltage of 0.566V and checked against the tolerance window defined in chapter 2.2.

### 4. Total harmonic distortion (THD)

Is measured according to IEC 268-5 (2nd to 5th harmonics) and the test setup in chapter 2.7 at input voltage of 0.566V and checked against the tolerance window defined in chapter 2.2.

## 2.8. Measurement setup for Hearing Aid

Tests are conducted at Z (Axial) direction, Y and X (Radial) directions  
Measurement Positions acc. to ANS

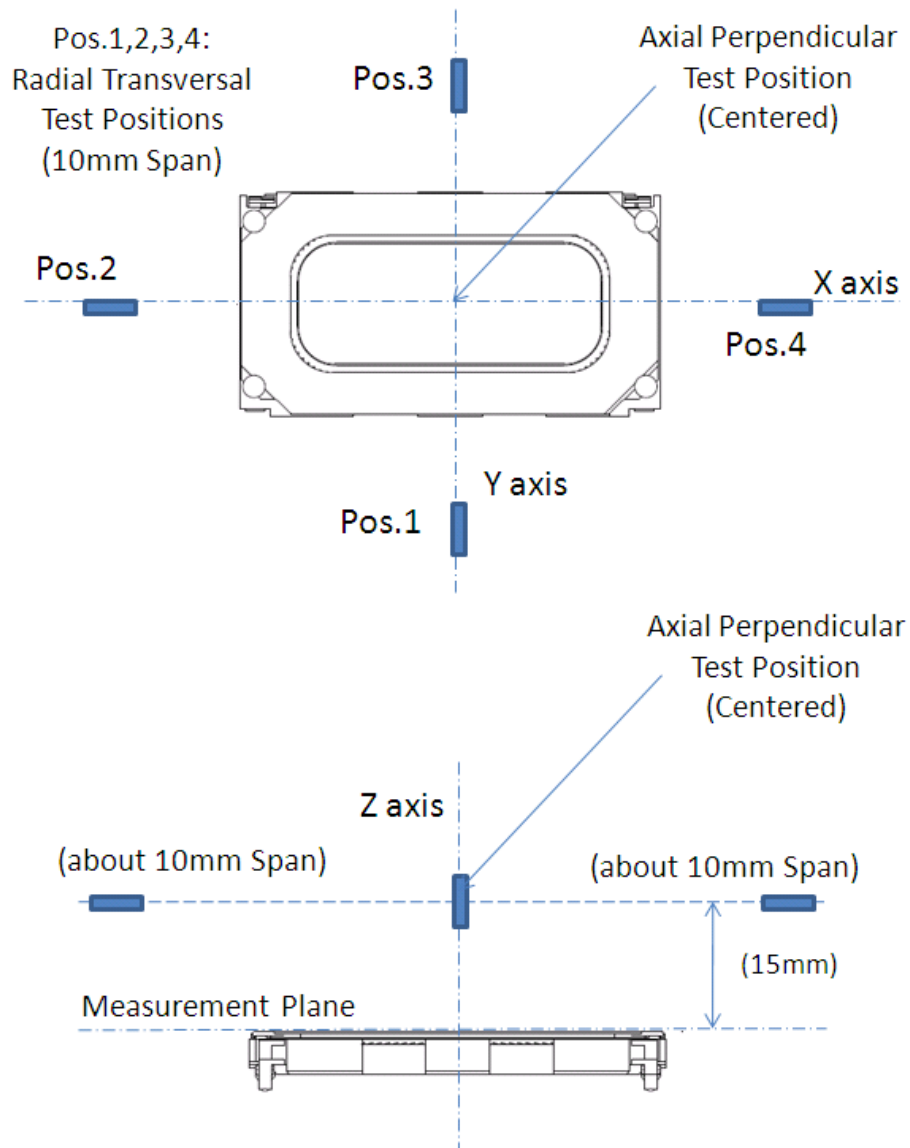

*\*Receiver must be mounted on a **plastic** surface, magnetic ambient levels be low as to not significantly affect the measurement, magnetic shielded chamber would be better.*

## 2.9. Packing information

See document: Packaging Instruction for 8x15x1.5 HAC Receiver  
2403-263-00094-299-EN\_A\_130805

## 2.10. Technical Delivery Terms

See Chapter

## 2.11. Final product measurement

Final product listening test: No audible R&B @10mW

## 2.12. Final product measurement

Final product listening test: No audible R&B @10m

## 3. Environmental Conditions

### 3.1. Storage

The transducer fulfils the specified data after treatment according to the conditions of

**ETS 300 019-2-1** Specification of environmental test: Storage  
Test spec. T 1.2: Weather protected, not temperature controlled storage locations.

### 3.2. Transportation

The transducer fulfils the specified data after treatment according to the conditions of

**ETS 300 019-2-2** Specification of environmental test: Transportation  
Test Spec. T 2.3: Public Transportation

### 3.3. Functionality

The transducer fulfils the specified data after treatment according to the conditions of

**ETS 300 019-2-5** Specification of environmental test: Ground vehicle installations  
Test spec. T 5.1: Protected installation

**ETS 300 019-2-7** Specification of environmental test: Portable and non-stationary use  
Test spec. T 7.3E: Partly weather protected and non-weather protected locations.

## 4. Environmental Tests

### 4.1. Qualification Tests

According to our milestone plan (Product Creation Process), a complete qualification test will be done at design validation on products, manufactured under serial conditions and 1x per year and product family. The qualification process covers all tests described under 4.5 and a complete inspection takes place.

## 4.2. Requalification Tests

1x per month and product family samples are taken and submitted to tests described under 4.5.2

## 4.3. Sample Size, Sequence

Unless otherwise stated 20 arbitrary new samples will be used to perform each test for both, qualification and requalification test as described under 4.1 and 4.2.

## 4.4. Period of Shelf-Life

The period of shelf-life is 5 years.

## 4.5. Testing Procedures

### 4.5.1. Storage Tests

#### Low Temperature Storage Test

Parameter	Test Method and Conditions	Duration	Evaluation Standard
Low Temperature Storage (Ref. BSI BS EN-60068-2-1)	-40°C rel. humidity not controlled	168h	Measurements of acoustic parameters shall be still within specification. Allowed deviations: Sensitivity is allowed to be within +/-3dB from initial value; The distortion shall not increase by more than a factor of 1.4 of the initial value measured at a single frequency bin. E.g.: distortion at frequency bin 400Hz which is initially 10% is allowed to be 14% after the test.

### High Temperature Storage Test

Parameter	Test Method and Conditions	Duration	Evaluation Standard
Dry Heat Storage (Ref. BSI BS EN-60068-2-2 )	+85°C rel. humidity not controlled	168h	Measurements of acoustic parameters shall be still within specification. Allowed deviations: Sensitivity is allowed to be within +/-3dB from initial value; The distortion shall not increase by more than a factor of 1.4 of the initial value measured at a single frequency bin. E.g.: distortion at frequency bin 400Hz which is initially 10% is allowed to be 14% after the test.

### Thermal shock Sequence

Parameter	Test Method and Conditions	Duration	Evaluation Standard
Change of Temperature (Ref. IEC 60068-2-14)	-40°C for 30min and then move to +85°C for 30min; Transition time < 3 min; 20 cycles (40 shocks);	20 cycles	Measurements of acoustic parameters shall be still within specification. Allowed deviations: Sensitivity is allowed to be within +/-3dB from initial value; The distortion shall not increase by more than a factor of 1.4 of the initial value measured at a single frequency bin. E.g.: distortion at frequency bin 400Hz which is initially 10% is allowed to be 14% after the test.



## Humidity Stress Tes

Parameter	Test Method and Conditions	Duration	Evaluation Standard
<b>Damp heat, cyclic</b> <b>(Ref. IEC 60068-2-3)</b>	85°C and 95% RH;	168hrs	Measurements of acoustic parameters shall be still within specification. Allowed deviations: Sensitivity is allowed to be within +/-3dB from initial value; The distortion shall not increase by more than a factor of 1.4 of the initial value measured at a single frequency bin. E.g.: distortion at frequency bin 400Hz which is initially 10% is allowed to be 14% after the test.

### 4.5.2. Operating Tests

#### Cold Operation Test

Parameter	Test Method and Conditions	Duration	Evaluation Standard
Cold Operation Test (Ref. BSI BS EN-60068-2-2, <b>Signal used to be agreed upon with RIM )</b>	-20°C rel. humidity not controlled	72h	Measurements of acoustic parameters shall be still within specification. Allowed deviations: Sensitivity is allowed to be within +/-3dB from initial value; The distortion shall not increase by more than a factor of 1.4 of the initial value measured at a single frequency bin. E.g.: distortion at frequency bin 400Hz which is initially 10% is allowed to be 14% after the test.

**Dry Heat Operation Test**

Parameter	Test Method and Conditions	Duration	Evaluation Standard
Dry Heat Operation (Ref. BSI BS EN-60068-2-1 Signal used to be agreed upon with RIM )	+70°C rel. humidity not controlled	500h	Measurements of acoustic parameters shall be still within specification. Allowed deviations: Sensitivity is allowed to be within +/-3dB from initial value; The distortion shall not increase by more than a factor of 1.4 of the initial value measured at a single frequency bin. E.g.: distortion at frequency bin 400Hz which is initially 10% is allowed to be 14% after the test.

**4.5.3. Salt Mist Test**

Parameter	Test Method and Conditions	Duration	Evaluation Standard
Salt Mist (Ref. IEC 60068-2-52)	The part must be subjected to 2 hours spray of 5% NaCl salt mist, at 35°C then be left at 40°C and 95% RH for 22 hrs.	3 cycles	Measurements of acoustic parameters shall be still within specification. Allowed deviations: Sensitivity is allowed to be within +/-3dB from initial value; The distortion shall not increase by more than a factor of 1.4 of the initial value measured at a single frequency bin. E.g.: distortion at frequency bin 400Hz which is initially 10% is allowed to be 14% after the test.

**4.5.4. Shock Resistance Test (Free Fall Test) - protected product**

Parameter	Test Method and Conditions	Duration	Evaluation Standard
Mechanical shock (Ref. IEC 60068-2-32)	Drop in test box or test adapter; Dropped onto concrete from 1.5m height; Two drops on	40 drops	Measurements of acoustic parameters shall be still within specification. Allowed deviations: Sensitivity is allowed to be

	each side (2x6); One drop on each edge (1x12); Two drops on each corner (2x8); In total of 40 drops		within +/-3dB from initial value; The distortion shall not increase by more than a factor of 1.4 of the initial value measured at a single frequency bin. E.g.: distortion at frequency bin 400Hz which is initially 10% is allowed to be 14% after the test there shall be no loose particles dissipated from the components during the test
--	---	--	---

#### 4.5.5. Impact Durability Test (Tumble Test) – protected product

Parameter	Test Method and Conditions	Duration	Evaluation Standard
Impact durability (in a Tumble Tester) (Ref. IEC60068-2-32Ed)	Impact durability (in a Tumble Tester) DUT in drop Test adapter/Jig 170grams; Jig size: 120mm*60mm*18mm; 100drops, 1m Random drops on steel base.	100 drops, 1m DUT power off	Measurements of acoustic parameters shall be still within specification. Allowed deviations: Sensitivity is allowed to be within +/-3dB from initial value; The distortion shall not increase by more than a factor of 1.4 of the initial value measured at a single frequency bin. E.g.: distortion at frequency bin 400Hz which is initially 10% is allowed to be 14% after the test there shall be no loose particles dissipated from the components during the test

#### 4.5.6. G-Force Test

Parameter	Test Method and Conditions	Duration	Evaluation Standard
G-Force Test	Test adapter 170grams; Jig size: 120mm*60mm*18mm; 5000g, 0.2msec;	/	Measurements of acoustic parameters shall be still within specification. Allowed deviations:

			<p>Sensitivity is allowed to be within +/-3dB from initial value;</p> <p>The distortion shall not increase by more than a factor of 1.4 of the initial value measured at a single frequency bin.</p> <p>E.g.: distortion at frequency bin 400Hz which is initially 10% is allowed to be 14% after the test</p> <p>There shall be no loose particles dissipated from the components during the test</p>
--	--	--	--

#### 4.5.7. Resistance to Electrostatic Discharge

Parameter	Test Method and Conditions	Duration	Evaluation Standard
Resistance to ESD IEC61000-4-2 Level 4 (SPR c 2.5.1)	One pole is grounded and the ESD pulse is applied to the other pole. The speaker must be stressed first with one polarisation and then with the other polarisation. DUT must be discharged between each ESD exposure. Level 4: contact +/- 8kV, air +/- 15kV	10 exposures on each polarity / 5 units DUT Power off	Measurements of acoustic parameters shall be still within specification. Allowed deviations: Sensitivity is allowed to be within +/-3dB from initial value; The distortion shall not increase by more than a factor of 1.4 of the initial value measured at a single frequency bin. E.g.: distortion at frequency bin 400Hz which is initially 10% is allowed to be 14% after the test.

#### 4.5.8. Sine Vibration Test

Parameter	Test Method and Conditions	Duration	Evaluation Standard
Sine Vibration Test (Ref. IEC 60068-2-6)	10–150 Hz, 50 m/sec <sup>2</sup> acceleration; 90 minute in each axis; 270 minutes (3 axes) in total;	270minutes	Measurements of acoustic parameters shall be still within specification. Allowed deviations: Sensitivity is allowed to be within +/-3dB from initial value;

			<p>The distortion shall not increase by more than a factor of 1.4 of the initial value measured at a single frequency bin.</p> <p>E.g.: distortion at frequency bin 400Hz which is initially 10% is allowed to be 14% after the test.</p> <p>There shall be no loose particles dissipated from the components during the test</p>
--	--	--	---

#### 4.5.9. Random Vibration Test

Parameter	Test Method and Conditions	Duration	Evaluation Standard
Random Vibration Test Ref. IEC 60068-2-64	5 – 500 Hz, 0.01g <sup>2</sup> /Hz; 100 minutes at each axis, total 300 minutes (3 axes)	300minutes	Measurements of acoustic parameters shall be still within specification. Allowed deviations: Sensitivity is allowed to be within +/-3dB from initial value; The distortion shall not increase by more than a factor of 1.4 of the initial value measured at a single frequency bin. E.g.: distortion at frequency bin 400Hz which is initially 10% is allowed to be 14% after the test. There shall be no loose particles dissipated from the components during the test.

#### 4.5.10. Mechanical Shock

Parameter	Test Method and Conditions	Duration	Evaluation Standard
Mechanical Shock Test Ref. IEC 60068-2-27	Peak acceleration 30G, 18 ms duration, 3.4m/s (half-sine); Six successive shocks shall be applied in each direction of three mutually perpendicular axes; In total of 18	18 shocks	Measurements of acoustic parameters shall be still within specification. Allowed deviations: Sensitivity is allowed to be within +/-3dB from initial value; The distortion shall not increase by more than a factor of 1.4 of the initial

	shocks		value measured at a single frequency bin. E.g.: distortion at frequency bin 400Hz which is initially 10% is allowed to be 14% after the test there shall be no loose particles dissipated from the components during the test.
--	--------	--	---

## 5. Related Documents

EN-60068-2	Environmental testing
IPC-SM-785	Guidelines for Accelerated Reliability Testing of Surface Mount Solder Attachment
IEC68-2-14	Temperature Change Testing Guideline
IEC68-2-3,1984	Humidity and Temperature Test guideline
IEC60068-2-52	Low air pressure environmental testing procedure
IEC60068-2-32	Free fall Test Procedure
IEC61000-4-2	ESD Test Guideline
IEC68-2-27	Mechanical Shock Test Guideline