

STRAIGHT SQUARE FLANGE JACK

R142.268.000

CLAMP TYPE - CABLE 6/75+93

Series : **BNC 75**

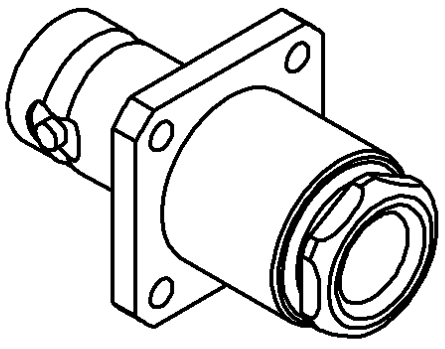
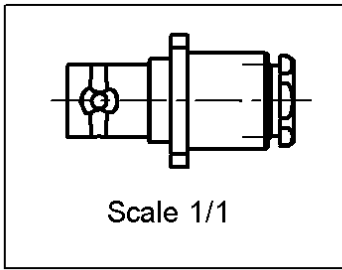
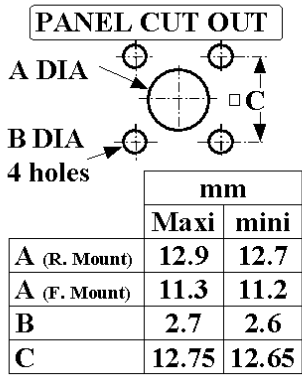
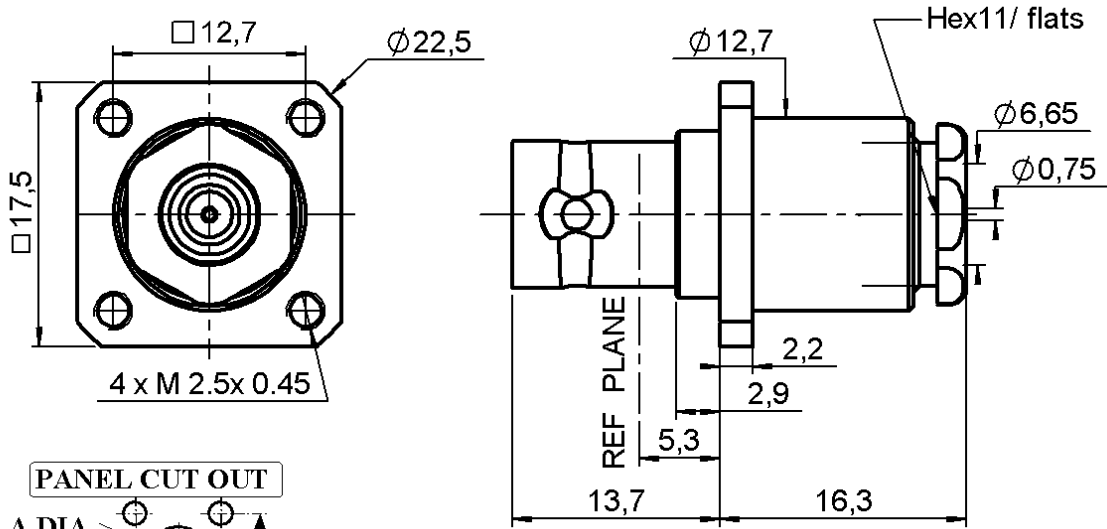

All dimensions are in mm.



COMPONENTS	MATERIALS	PLATINGS (µm)
BODY	BRASS	NICKEL 2
CENTER CONTACT	BERYLLIUM COPPER	GOLD 0.5 OVER NICKEL 2
OUTER CONTACT	-	-
INSULATOR	PTFE	-
GASKET	SILICONE RUBBER	-
OTHERS PARTS	BRASS	NICKEL 2
-	-	-
-	-	-

Issue : 0329 F

In the effort to improve our products, we reserve the right to make changes judged to be necessary.



STRAIGHT SQUARE FLANGE JACK

R142.268.000

CLAMP TYPE - CABLE 6/75+93

Series : **BNC 75**

PACKAGING

Standard	Unit	Other
100	'W' option	Contact us

SPECIFICATION

ELECTRICAL CHARACTERISTICS

Impedance		75 Ω
Frequency		0-1.5 GHz
VSWR	1.30 +	0.000 x F(GHz) Maxi
Insertion loss		0.115 √F(GHz) dB Maxi
RF leakage	- (57 - F(GHz)) dB Maxi
Voltage rating		500 Veff Maxi
Dielectric withstanding voltage		1500 Veff mini
Insulation resistance		5000 MΩ mini

CABLE ASSEMBLY

Stripping	a	b	c	d	e	f
mm	5.50	6.00	0.00	0.00	0.50	0.00

Assembly instruction : **Clamp 02**

Recommended cable(s)
KX 6A
RG 59

Characteristics indicated on this data sheet are those that can be achieved with the highest performance cable. Intrinsic limitations of the cable may diminish the performance of the assembly

Cable retention

- pull off **180** N mini
- torque **NA** N.cm

MECHANICAL CHARACTERISTICS

Center contact retention		
Axial force – Mating end		27 N mini
Axial force – Opposite end		27 N mini
Torque		NA N.cm mini

TOOLING

Part Number	Description	Hexagon
.	.	.

Recommended torque		
Mating		NA N.cm
Panel nut		NA N.cm
Clamp nut		450 N.cm
A/F clamp nut		11.000 mm

Mating life		500 Cycles mini
Weight		18.000 g

OTHERS CHARACTERISTICS

-

ENVIRONMENTAL

Operating temperature		-65/+165 °C
Hermetic seal		NA Atm.cm3/s
Panel leakage		NA

Issue : **0329 F**

In the effort to improve our products, we reserve the right to make changes judged to be necessary.

