

**STRAIGHT MALE RECEPTACLE FOR PCB
SMT TYPE - EDGE CARD**

R114.423.000
SERIES **SMB**

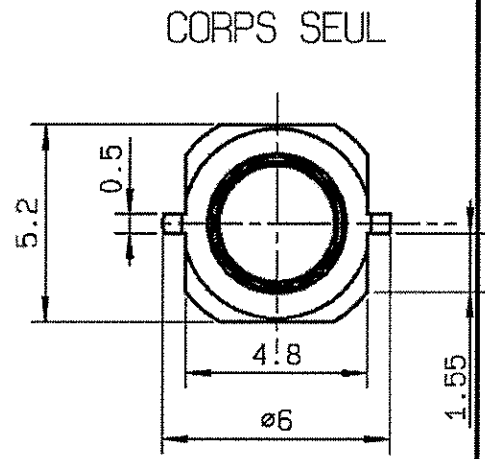
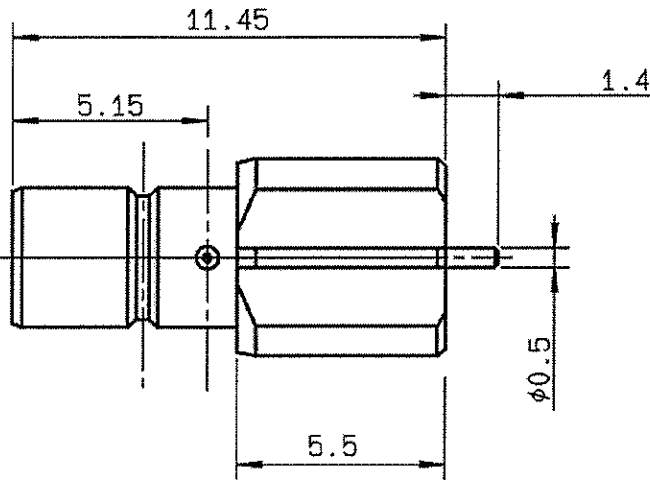

NOMINAL IMPEDANCE	50	Ω
FREQUENCY RANGE	0-4	GHz
TEMPERATURE RATING	-65/+165	°C
V.S.W.R	1.05* + .008 x F(GHz)Maxi	
RF INSERTION LOSS	0.03* √F(GHz)	dB Maxi
VOLTAGE RATING	500	Veff Maxi
DIELECTRIC WITHSTANDING VOLTAGE	1000	Veff Mini
INSULATION RESISTANCE	1000	MΩMini
HERMETIC SEAL	NA	Atm.cm ³ /s
LEAKAGE (pressurized only)	NA	
MECHANICAL DURABILITY	500	Cycles
WEIGHT	1.3	gr
SPECIFICATION		

CABLES :

OTHERS CHARACTERISTICS
*** COAXIAL TRANSMISSION LINE ONLY**

CABLE RETENTION	NA	N Mini
CENTER CONTACT RETENTION		
Axial force - mating end	10	N Mini
Axial force - opposite end	10	N Mini
Torque	NA	cm.N Mini
RECOMMENDED TORQUES		
Mating	NA	cm.N
Panel nut	NA	cm.N
Clamp nut	NA	cm.N

CONNECTOR PARTS	MATERIALS	FINISH	(all values are given in micrometers)
BODY	BRASS	GOLD 0.2 OVER NICKEL 2	
OUTER CONTACT			
CENTER CONTACT	BRASS	GOLD 0.5 OVER NICKEL 2	
INSULATOR	PTFE	-	
GASKET		-	
OTHERS PIECES			

GONZALES

ISSUE 0735 C	CREATION DATE 14/06/1994	FILE PART-NUMBER EPC 94-04
------------------------	------------------------------------	--------------------------------------



The information given here is subject to change without notice. Design changes may be in order to improve the product.

Connect to the future



R114.423.000		
ISSUE	0735C	SERIES
		SMB

SMB SERIES - INFORMATIONS
SOLDER PROCEDURE OF RECEPTACLES IN INDUSTRIAL ENVIRONMENT

- 1 - Deposit solder paste "Sn63Pb35Ag2" on mounting zone by screen printing application. We advise a thickness of 200 micromm (7.800 microinch). Verify that the edges of the zone are clean.
- 2 - Deposit the receptacle on the mounting zone .
 Video camera is preferred to check the positioning of the component. (See page 3)
 Adhesive agents are forbidden on the receptacle.
- 3 - Soldering by infra-red reflow.
 We give under, the typical profile to use.
- 4 - Cleaning of printed circuit boards by DFC solvents (or a substitute product according to the United Nation's environmental programm).
 We advise the vapor-phase method, with or without any ultrasonic waves.
 This cleaning is imperative for using the receptacle.
- 5 - Checking of solder joints and position of the component by visual inspection.

TEMPERATURE PROFIL

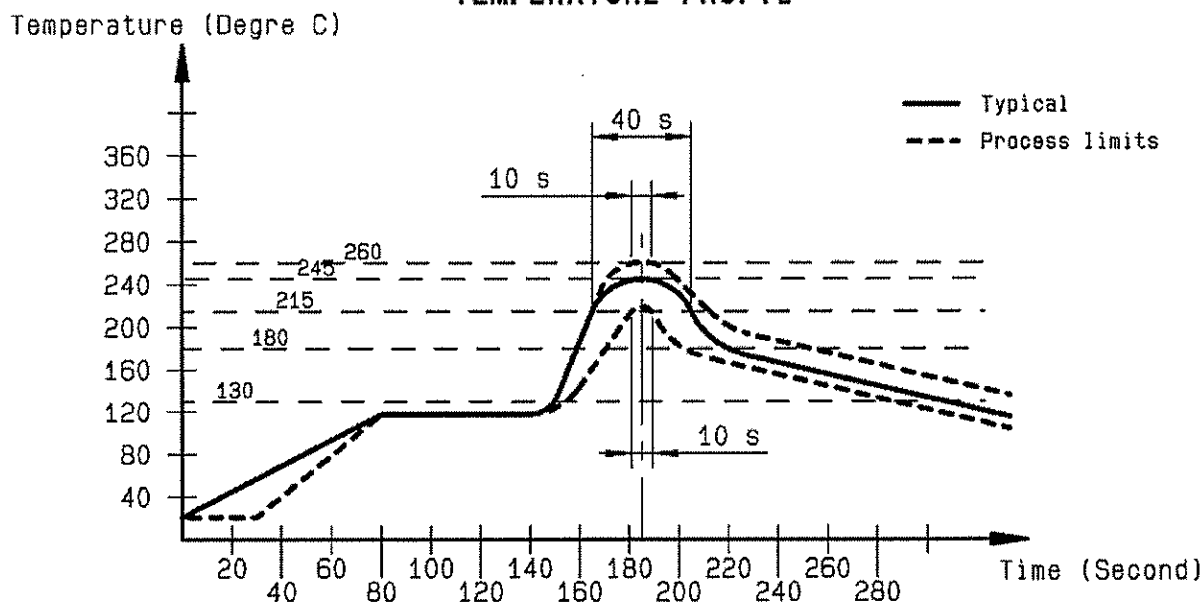

GONZALES



R114.423.000

ISSUE 0735 C SERIES SMB

SMB SERIE - INFORMATIONS

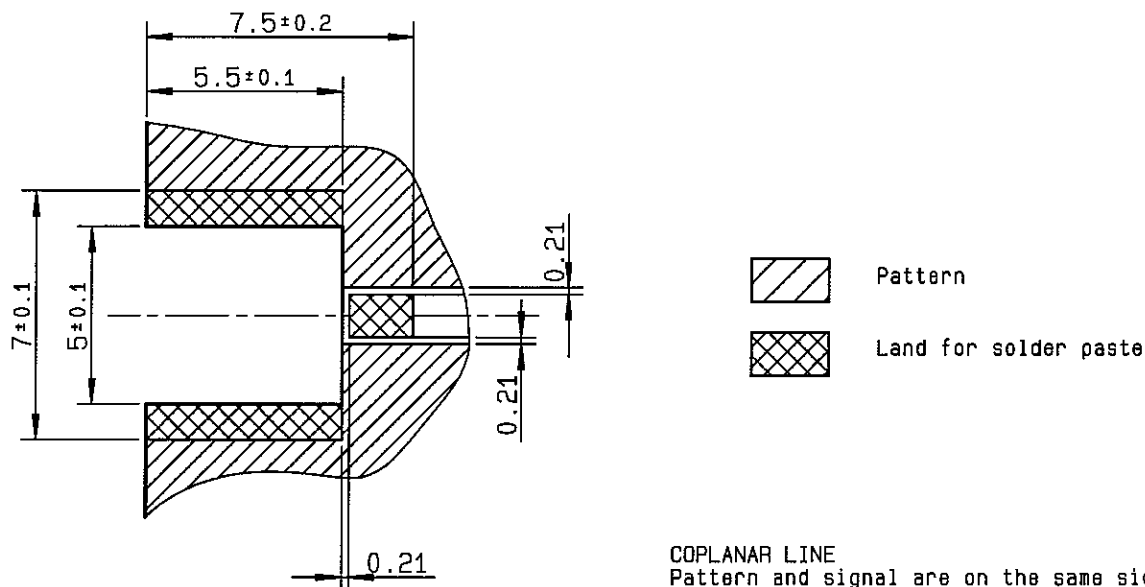

COPLANAR LINE
 Pattern and signal are on the same side
 Thickness of PCB : .063 (1.6 mm)
 The material of PCB is the epoxy resin of glass fabrics bacs.(Er = 4.8)
 The solder resist should be printed except for the land pattern on the PCB.

SHADOW OF SMB RECEPTACLE FOR VIDEO CAMERA

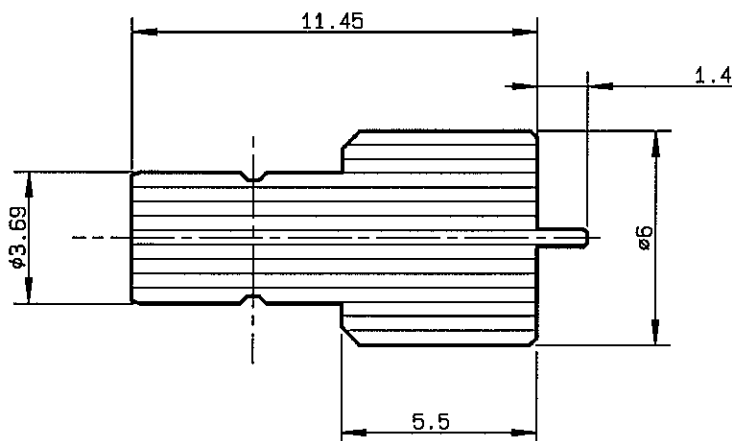

GONZALES