

LOC	DIST	REVISIONS			
P	LTR	DESCRIPTION	DATE	DMY	APVD
A		REV PER 0600-7485-98	5-98	CT	JW

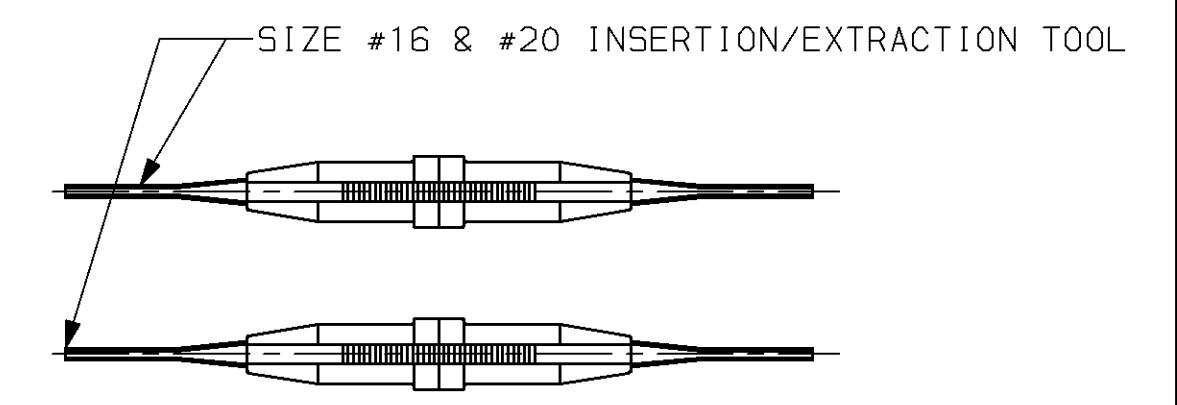
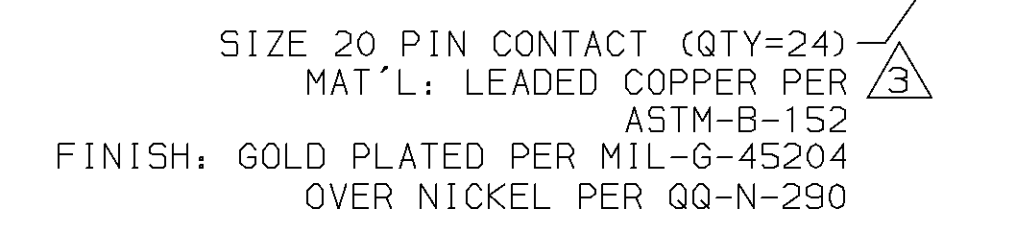
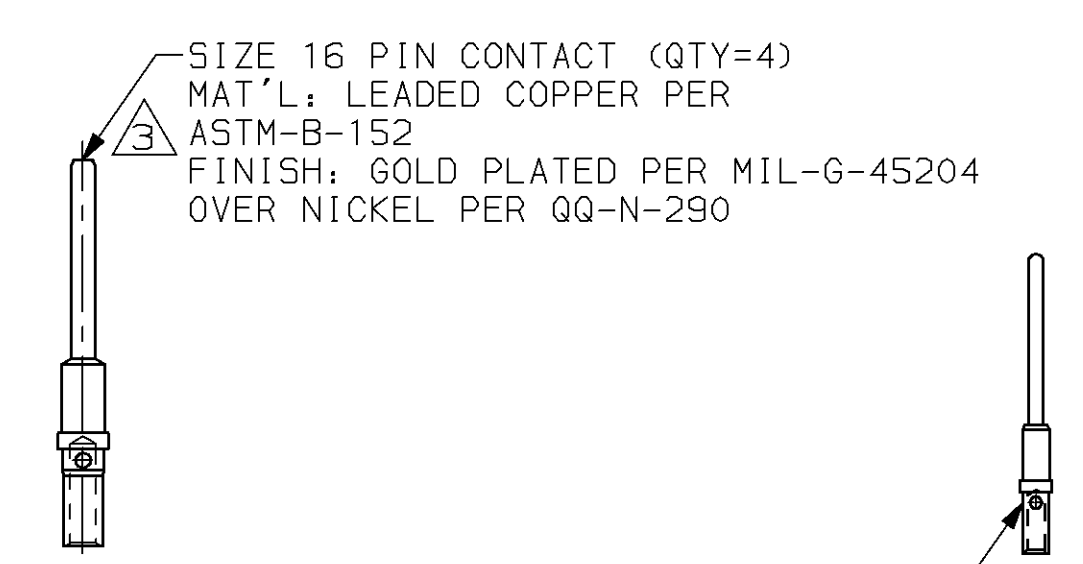
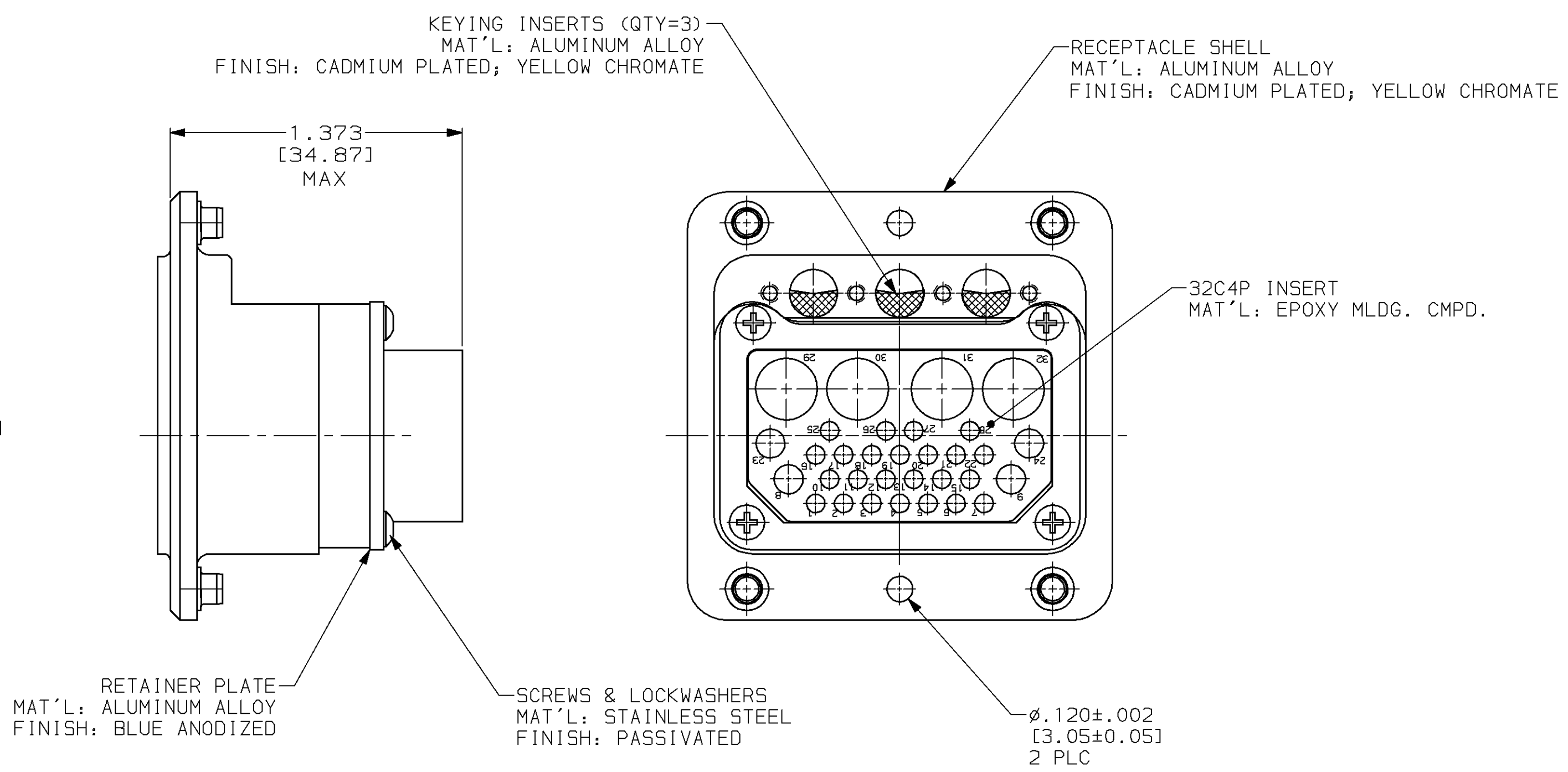
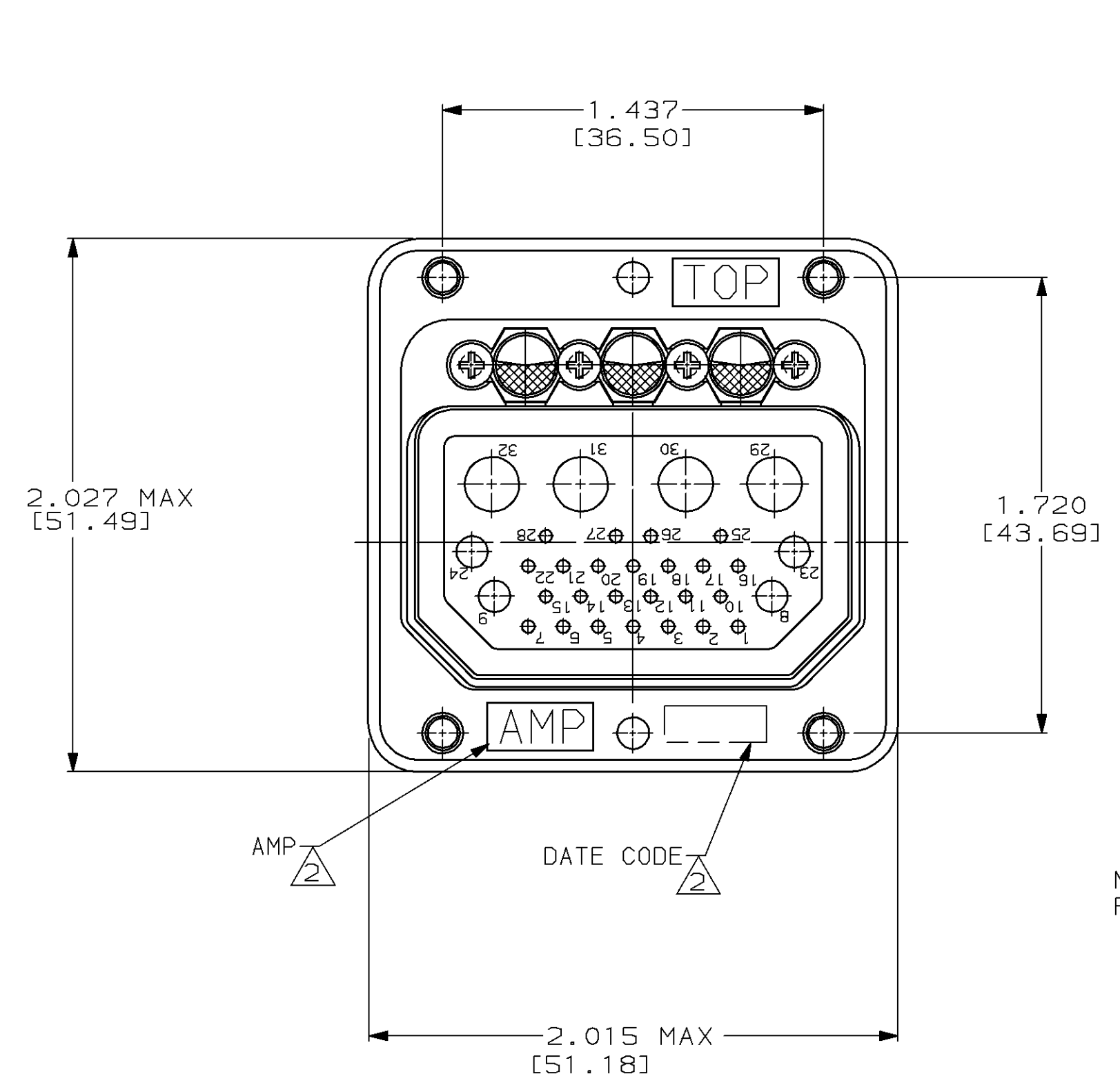
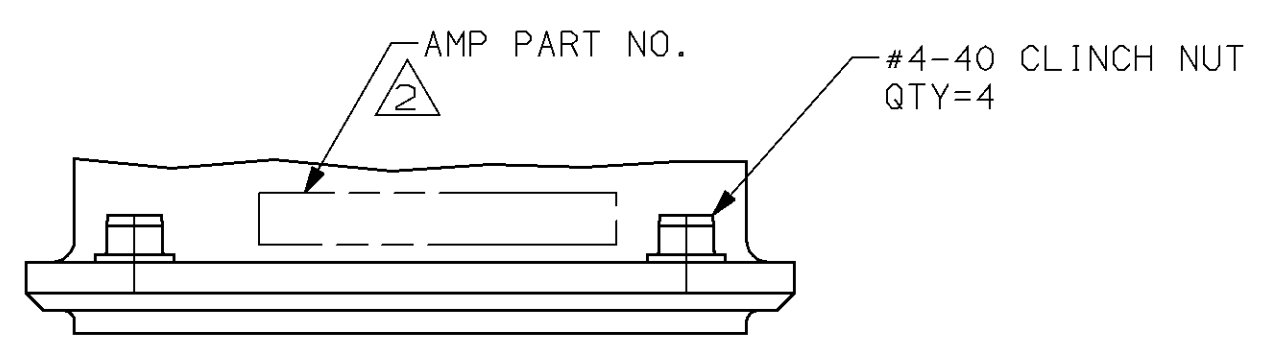

- KEYING ASSEMBLED IN POSITION 01.
- △ AMP, AMP PART NO. AND DATE CODE MARKED IN AREA SHOWN.
 - △ CONTACTS ARE PACKAGED IN A SEPARATE CONTAINER AND SHIPPED WITH CONNECTOR. COAX CONTACTS MUST BE ORDERED SEPARATELY.

1218039-1
 PART NUMBER

THIS DRAWING IS A CONTROLLED DOCUMENT.		DMY C. C. THOMAS 5-19-98	AMP Incorporated Harrisburg, PA 17105-3608	
DIMENSIONS: INCHES (MM)	TOLERANCES UNLESS OTHERWISE SPECIFIED:	CHK J. WEAVER 5-19-98	APVD J. WEAVER 5-19-98	NAME RECEPTACLE ASSY, ARINC 404 RM1R32C4P-0101
0 PLC ±-	1 PLC ±-	PRODUCT SPEC	APPLICATION SPEC	SIZE A1
2 PLC ±-	3 PLC ±.005 (0.13)	WEIGHT	SCALE	CAGE CODE 00779
4 PLC ±-	ANGLES ±-	CUSTOMER DRAWING	SCALE 2:1	DRAWING NO 1218039
MATERIAL SEE CALLOUTS	FINISH SEE CALLOUTS	RESTRICTED TO	SHEET 1 OF 1	REV A