

PRODUCT NUMBER
95615-XXXXLF

PLATING

- 0 = 0.20µm GOLD/GXT ON CONTACT AREA
2µm MIN MATTE TIN ON TAIL
 - 1 = 0.76µm GOLD/GXT ON CONTACT AREA
2µm MIN MATTE TIN ON TAIL
 - 3 = 0.38µm GOLD/GXT ON CONTACT AREA
2µm MIN MATTE TIN ON TAIL
 - 5 = 0.38µm GXT FULL PLATED
 - 6 = 0.76µm GXT FULL PLATED
 - 7 = 0.76µm GOLD/GXT FULL PLATED
 - 9 = 0.20µm GOLD/GXT FULL PLATED
- 1.27µm Ni MIN UNDERPLATING

- RoHS COMPATIBLE, SEE NOTE 6
- PACKAGING, SEE NOTE 5
- TOTAL NB OF POSITIONS, 08 TO 34

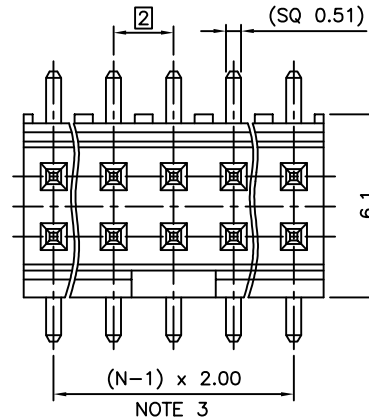

STANDARD PICK-UP CAP

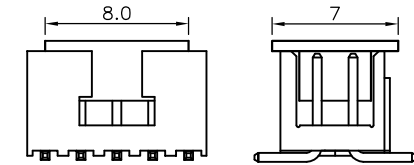
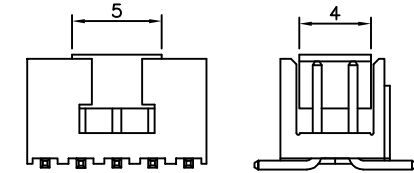

LARGE PICK-UP CAP NOTE 5
NOT AVAILABLE FOR 2X2

NOTES:

1. MATERIAL HOUSING: HIGH TEMP. THERMOPLASTIC
UL 94V-0, COLOR CREAM
2. MATERIAL TERMINAL: COPPER ALLOY
3. TO DETERMINE DIMENSIONS:
N = NUMBER OF POSITIONS PER ROW
4. 7N MIN. PIN RETENTION IN EITHER DIRECTION.
5. PACKAGING:

- = POLYBAGS
- T = TUBE AVAILABILITY : FROM 2x5 UP TO 2x 17
- B = TUBE WITH PICK UP CAP AVAILABLE FROM 2x5 UP TO 2x 17
- K = TAPE AND REEL WITHOUT PICK-UP CAP, AS AVAILABLE
- A = TAPE AND REEL WITH LARGE PICK-UP CAP, AS AVAILABLE
- TR = TAPE AND REEL WITH PICK-UP CAP, AS AVAILABLE.

6. RoHS COMPATIBLE PRODUCT SPECIFICATIONS

- a - PLATING:
 - "LF" MEANS THE PRODUCT IS LEAD-FREE,
2µm MINIMUM MATTE TIN OVER 1.27µm
MINIMUM NICKEL UNDERPLATE.
- b - MANUFACTURING PROCESS COMPATIBILITY
 - THE HOUSING WILL WITHSTAND EXPOSURE TO
260°C PEAK TEMPERATURE FOR 30 SECONDES
MAX IN A CONVECTION, INFRA-RED OR VAPOR
PHASE OR REFLOW OVEN.
- c - LABELLING:
 - MEETS PACKAGING SPECS AS PER GS-14-920
- d - THIS PRODUCT MEETS EUROPEAN DIRECTIVES
AND OTHER COUNTRY REGULATIONS AS DISCRIBED
IN GS-47-0004.

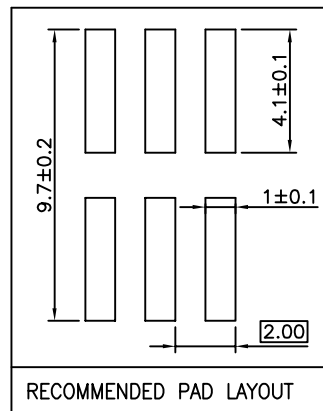
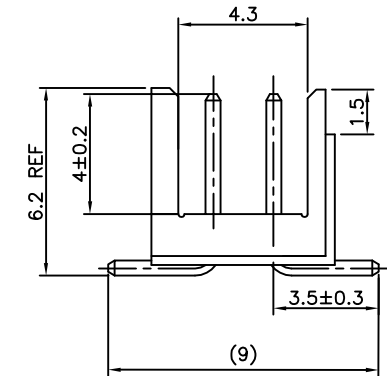
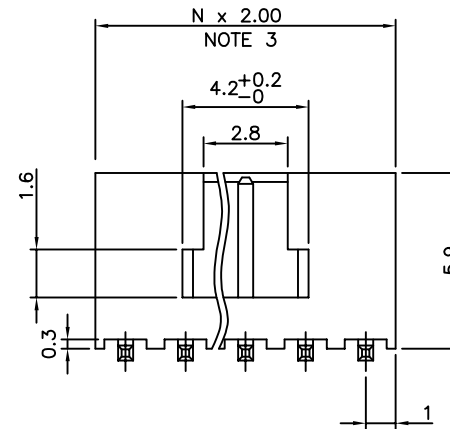

mat'l. code SEE NOTES		surface ISO 1302	tolerance ISO 406 ISO	projection 101	product family MINITEK HEADER
ltr	ecn no	dr	date	tolerances unless otherwise specified	title
T	F-23051	AMA	16.01.15	linear .X ±0.3 .XX ±0.13 .XXX ±0.05	SHR HEADER 2.00mm SMT
M	F07-0191	J.CO	07.09.05	±2'	scale 7:1
N	F08-0145	ELA	08.04.15	dr	JL.CORDIER 97.07.26
P	F11-0071	JCO	11.06.17	engr	J.COMPAGNON 97.07.26
R	F11-0339	JCO	11.12.06	chr	JL.CORDIER 97.07.26
S	B-19190	LMU	14.10.24	appo	J.COMPAGNON 97.07.26
sheet index	revision sheet				sheet 1 of 1 size
					95615 A3
					type CUSTOMER Drawing