

# Current Transducer HLSR-SM/SP33 series $I_{PN} = 10 \dots 50 \text{ A}$

Ref: HLSR 10-SM/SP33, HLSR 20-SM/SP33, HLSR 32-SM/SP33,  
HLSR 40-SM/SP33, HLSR 50-SM/SP33

For the electronic measurement of currents: DC, AC, pulsed..., with galvanic separation between the primary and the secondary circuit.

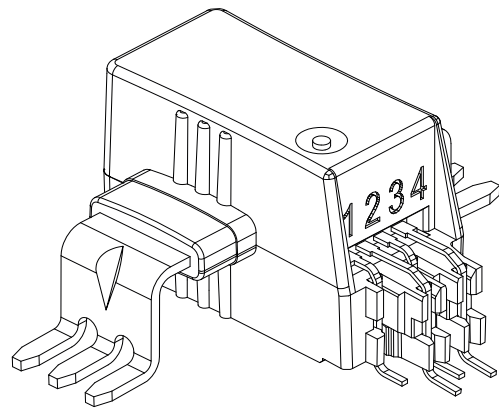

## Features

- Open loop multi-range current transducer
- Voltage output
- Galvanic separation between primary and secondary
- Low power consumption
- Compact design for surface mount PCB mounting
- Factory calibrated
- High bandwidth, very low loss magnetic core.

## Special feature

- Single supply +3.3 V.

## Advantages

- Extremely low profile: h = 12 mm
- Low foot-print
- Low offset drift
- Over-drivable  $U_{ref}$ .

## Applications

- AC variable speed and servo motor drives
- Static converters for DC motor drives
- Battery supplied applications
- Uninterruptible Power Supplies (UPS)
- Switched Mode Power Supplies (SMPS)
- Power supplies for welding applications
- Combiner box
- MPPT.

## Standards

- EN 50178: 1997
- IEC 61010-1: 2010
- IEC 61326-1: 2012
- UL 508: 2010.

## Application Domain

- Industrial.

### Absolute maximum ratings

Parameter	Symbol	Unit	Value
Supply voltage (not destructive)	$U_C$	V	8
Supply voltage (not entering non standard modes)	$U_C$	V	6.5
Primary conductor temperature	$T_B$	°C	120
Electrostatic discharge voltage (HBM - Human Body Model)	$U_{ESD\ HBM}$	kV	2

Stresses above these ratings may cause permanent damage.  
Exposure to absolute maximum ratings for extended periods may degrade reliability.

### UL 508: Ratings and assumptions of certification

File # E189713 Volume: 2 Section: 5

#### Standards

- CSA C22.2 NO. 14-10 INDUSTRIAL CONTROL EQUIPMENT - Edition 11 - Revision Date 2011/08/01
- UL 508 STANDARD FOR INDUSTRIAL CONTROL EQUIPMENT - Edition 17 - Revision Date 2010/04/15

#### Ratings

Parameter	Symbol	Unit	Comment
Primary involved potential		V AC/DC	600
Max surrounding air temperature	$T_A$	°C	105
Primary current	$I_P$	A	According to series primary current
Secondary supply voltage	$U_C$	V DC	5
Output voltage	$U_{out}$	V	0 to 5

### Conditions of acceptability

- 1 - These devices have been evaluated for overvoltage category III and for use in pollution degree 2 environment.
- 2 - A suitable enclosure shall be provided in the end-use application.
- 3 - The terminals have not been evaluated for field wiring.
- 4 - These devices are intended to be mounted on a printed wiring board of end use equipment. The suitability of the connections (including spacings) shall be determined in the end-use application.
- 5 - Primary terminals shall not be straightened since assembly of housing case depends upon bending of the terminals.
- 6 - Any surface of polymeric housing have not been evaluated as insulating barrier.
- 7 - Low voltage control circuit shall be supplied by an isolating source (such as a transformer, optical isolator, limiting impedance or electro-mechanical relay).

### Marking

Only those products bearing the UR Mark should be considered to be Listed or Recognized and covered under UL's Follow-Up Service. Always look for the Mark on the product.

**Insulation coordination**

Parameter	Symbol	Unit	≤ Value	Comment
RMS voltage for AC insulation test, 50/60 Hz, 1 min	$U_d$	kV	4.3	
Impulse withstand voltage 1.2/50 $\mu$ s	$U_{Ni}$	kV	8	
Clearance (pri. - sec.)	$d_{Cl}$	mm	8	Shortest distance through air
Creepage distance (pri. - sec.)	$d_{Cp}$	mm	8	Shortest path along device body
Clearance (pri. - sec.)	-	mm	8	When mounted on PCB with recommended layout
Case material	-	-	V0	According to UL 94
Comparative tracking index	<i>CTI</i>		600	
Application example		V	600	Reinforced insulation, CAT III, PD2, non uniform field according to EN 50178, IEC 61010
Application example		V	1000	Basic insulation, CAT III, PD2, non uniform field according to EN 50178, IEC 61010
Application example		V	600	According to UL 508

**Environmental and mechanical characteristics**

Parameter	Symbol	Unit	Min	Typ	Max	Comment
Ambient operating temperature	$T_A$	°C	-40		105	
Ambient storage temperature	$T_{Ast}$	°C	-40		105	
Mass	$m$	g			5	

**Electrical data HLSR 10-SM/SP33**

 At  $T_A = 25\text{ °C}$ ,  $U_C = +3.3\text{ V}$ ,  $R_L = 10\text{ k}\Omega$  unless otherwise noted (see Min, Max, typ, definition paragraph in [page 9](#)).

Parameter	Symbol	Unit	Min	Typ	Max	Comment
Primary nominal RMS current	$I_{PN}$	A		10		
Primary current, measuring range	$I_{PM}$	A	-25		25	For $U_C = +3.3\text{ V} \pm 5\%$
Number of primary turns	$N_P$	-		1		
Resistance of primary jumper @ $T_A = 25\text{ °C}$	$R_P$	m $\Omega$		0.21		
Resistance of primary jumper @ $T_A = 105\text{ °C}$	$R_P$	m $\Omega$		0.29		$T$ jumper = $120\text{ °C}$
Supply voltage	$U_C$	V	3.135	3.3	3.465	
Current consumption	$I_C$	mA		19	25	
Reference voltage (output)	$U_{ref}$	V	1.63	1.65	1.67	Internal reference
Reference voltage (input)	$U_{ref}$	V	0.5		1.7	External reference
Output voltage range @ $I_{PM}$	$U_{out} - U_{ref}$	V	-1.15		1.15	Over operating temperature range
Internal series resistance of reference voltage	$R_{ref}$	$\Omega$	130	200	300	series
Output internal resistance	$R_{out}$	$\Omega$		2	5	series
Load capacitance	$C_L$	nF	0		6	
Electrical offset voltage referred to primary @ $I_P = 0$	$U_{OE}$	mV	-5		5	$U_{out} - U_{ref}$ @ $U_{ref} = 1.65\text{ V}$ Not guaranteed in REF IN mode with external reference $U_{ref} \neq 1.65\text{ V}$
Electrical offset current referred to primary	$I_{OE}$	mA	-109		109	
Temperature coefficient of $U_{ref}$	$TCU_{ref}$	ppm/K	-150		150	$-40\text{ °C} \dots 105\text{ °C}$
Temperature coefficient of $U_{OE}$ referred to primary	$TCU_{OE}$	mV/K	-0.075		0.075	
Temperature coefficient of $I_{OE}$ referred to primary	$TCI_{OE}$	mA/K	-1.63		1.63	
Nominal sensitivity	$S_N$	mV/A		46		460 mV @ $I_{PN}$
Sensitivity error	$\varepsilon_S$	%	-0.5		0.5	Factory adjustment
Temperature coefficient of $S$	$TCS$	ppm/K	-200		200	
Linearity error 0 ... $I_{PN}$	$\varepsilon_L$	% of $I_{PN}$	-0.5		0.5	
Linearity error 0 ... $I_{PM}$	$\varepsilon_L$	% of $I_{PM}$	-0.8		0.8	
Magnetic offset current (@ $10 \times I_{PN}$ ) referred to primary	$I_{OM}$	A	-0.25		0.25	
Delay time @ 10 % of the final output value for $I_{PN}$ step	$t_{D10}$	$\mu\text{s}$			2	@ 50 A/ $\mu\text{s}$
Delay time @ 90 % of the final output value for $I_{PN}$ step	$t_{D90}$	$\mu\text{s}$			2.5	@ 50 A/ $\mu\text{s}$
Frequency bandwidth (-3 dB)	$BW$	kHz		450		
Noise voltage spectral density referred to primary 100 Hz ... 100 kHz	$u_{no}$	$\mu\text{V}/\sqrt{\text{Hz}}$			16	
RMS noise voltage referred to primary DC ... 10 kHz DC ... 100 kHz DC ... 1 MHz	$U_{no}$	mVpp		9 22 40		
Sum of sensitivity and linearity @ $I_{PN}$	$\varepsilon_{SL}$	% of $I_{PN}$	-1		1	
Sum of sensitivity and linearity @ $I_{PN}$ @ $T_A = +85\text{ °C}$	$\varepsilon_{SL85\text{ °C}}$	% of $I_{PN}$	-3.2		3.2	See formula note <sup>1)</sup>
Sum of sensitivity and linearity @ $I_{PN}$ @ $T_A = +105\text{ °C}$	$\varepsilon_{SL105\text{ °C}}$	% of $I_{PN}$	-3.9		3.9	See formula note <sup>1)</sup>

Note: <sup>1)</sup>  $\varepsilon_{SL}(T_A) = \varepsilon_{SL25} + \left( TCS + \frac{TCI_{OE}}{I_{PN}} \right) \times |T_A - 25|$

**Electrical data HLSR 20-SM/SP33**

 At  $T_A = 25\text{ °C}$ ,  $U_C = +3.3\text{ V}$ ,  $R_L = 10\text{ k}\Omega$  unless otherwise noted (see Min, Max, typ, definition paragraph in [page 9](#)).

Parameter	Symbol	Unit	Min	Typ	Max	Comment
Primary nominal RMS current	$I_{PN}$	A		20		
Primary current, measuring range	$I_{PM}$	A	-50		50	For $U_C = +3.3\text{ V} \pm 5\%$
Number of primary turns	$N_P$	-		1		
Resistance of primary jumper @ $T_A = 25\text{ °C}$	$R_P$	m $\Omega$		0.21		
Resistance of primary jumper @ $T_A = 105\text{ °C}$	$R_P$	m $\Omega$		0.29		$T$ jumper = $120\text{ °C}$
Supply voltage	$U_C$	V	3.135	3.3	3.465	
Current consumption	$I_C$	mA		19	25	
Reference voltage (output)	$U_{ref}$	V	1.63	1.65	1.67	Internal reference
Reference voltage (input)	$U_{ref}$	V	0.5		1.7	External reference
Output voltage range @ $I_{PM}$	$U_{out} - U_{ref}$	V	-1.15		1.15	Over operating temperature range
Internal series resistance of reference voltage	$R_{ref}$	$\Omega$	130	200	300	series
Output internal resistance	$R_{out}$	$\Omega$		2	5	series
Load capacitance	$C_L$	nF	0		6	
Electrical offset voltage referred to primary @ $I_P = 0$	$U_{OE}$	mV	-5		5	$U_{out} - U_{ref}$ @ $U_{ref} = 1.65\text{ V}$ Not guaranteed in REF IN mode with external reference $U_{ref} \neq 1.65\text{ V}$
Electrical offset current referred to primary	$I_{OE}$	mA	-217		217	
Temperature coefficient of $U_{ref}$	$TCU_{ref}$	ppm/K	-150		150	-40 °C ... 105 °C
Temperature coefficient of $U_{OE}$ referred to primary	$TCU_{OE}$	mV/K	-0.075		0.075	
Temperature coefficient of $I_{OE}$ referred to primary	$TCI_{OE}$	mA/K	-3.26		3.26	
Nominal sensitivity	$S_N$	mV/A		23		460 mV @ $I_{PN}$
Sensitivity error	$\epsilon_s$	%	-0.5		0.5	Factory adjustment
Temperature coefficient of $S$	$TCS$	ppm/K	-200		200	
Linearity error 0 ... $I_{PN}$	$\epsilon_L$	% of $I_{PN}$	-0.5		0.5	
Linearity error 0 ... $I_{PM}$	$\epsilon_L$	% of $I_{PM}$	-0.8		0.8	
Magnetic offset current (@ $10 \times I_{PN}$ ) referred to primary	$I_{OM}$	A	-0.25		0.25	
Delay time @ 10 % of the final output value for $I_{PN}$ step	$t_{D10}$	$\mu\text{s}$			2	@ 50 A/ $\mu\text{s}$
Delay time @ 90 % of the final output value for $I_{PN}$ step	$t_{D90}$	$\mu\text{s}$			2.5	@ 50 A/ $\mu\text{s}$
Frequency bandwidth (-3 dB)	$BW$	kHz		450		
Noise voltage spectral density referred to primary 100 Hz ... 100 kHz	$u_{no}$	$\mu\text{V}/\sqrt{\text{Hz}}$			8	
RMS noise voltage referred to primary DC ... 10 kHz DC ... 100 kHz DC ... 1 MHz	$U_{no}$	mVpp		6 13 23		
Sum of sensitivity and linearity @ $I_{PN}$	$\epsilon_{SL}$	% of $I_{PN}$	-1		1	
Sum of sensitivity and linearity @ $I_{PN}$ @ $T_A = +85\text{ °C}$	$\epsilon_{SL85\text{ °C}}$	% of $I_{PN}$	-3.2		3.2	See formula note <sup>1)</sup>
Sum of sensitivity and linearity @ $I_{PN}$ @ $T_A = +105\text{ °C}$	$\epsilon_{SL105\text{ °C}}$	% of $I_{PN}$	-3.9		3.9	See formula note <sup>1)</sup>

**Note:** <sup>1)</sup>  $\epsilon_{SL}(T_A) = \epsilon_{SL25} + \left( TCS + \frac{TCI_{OE}}{I_{PN}} \right) \times |T_A - 25|$

**Electrical data HLSR 32-SM/SP33**

 At  $T_A = 25\text{ °C}$ ,  $U_C = +3.3\text{ V}$ ,  $R_L = 10\text{ k}\Omega$  unless otherwise noted (see Min, Max, typ, definition paragraph in [page 9](#)).

Parameter	Symbol	Unit	Min	Typ	Max	Comment
Primary nominal RMS current	$I_{PN}$	A		32		
Primary current, measuring range	$I_{PM}$	A	-80		80	For $U_C = +3.3\text{ V} \pm 5\%$
Number of primary turns	$N_P$	-		1		
Resistance of primary jumper @ $T_A = 25\text{ °C}$	$R_P$	m $\Omega$		0.21		
Resistance of primary jumper @ $T_A = 105\text{ °C}$	$R_P$	m $\Omega$		0.29		$T$ jumper = $120\text{ °C}$
Supply voltage	$U_C$	V	3.135	3.3	3.465	
Current consumption	$I_C$	mA		19	25	
Reference voltage (output)	$U_{ref}$	V	1.63	1.65	1.67	Internal reference
Reference voltage (input)	$U_{ref}$	V	0.5		1.7	External reference
Output voltage range @ $I_{PM}$	$U_{out} - U_{ref}$	V	-1.15		1.15	Over operating temperature range
Internal series resistance of reference voltage	$R_{ref}$	$\Omega$	130	200	300	series
Output internal resistance	$R_{out}$	$\Omega$		2	5	series
Load capacitance	$C_L$	nF	0		6	
Electrical offset voltage referred to primary @ $I_P = 0$	$U_{OE}$	mV	-5		5	$U_{out} - U_{ref}$ @ $U_{ref} = 1.65\text{ V}$ Not guaranteed in REF IN mode with external reference $U_{ref} \neq 1.65\text{ V}$
Electrical offset current referred to primary	$I_{OE}$	mA	-348		348	
Temperature coefficient of $U_{ref}$	$TCU_{ref}$	ppm/K	-150		150	$-40\text{ °C} \dots 105\text{ °C}$
Temperature coefficient of $U_{OE}$ referred to primary	$TCU_{OE}$	mV/K	-0.075		0.075	
Temperature coefficient of $I_{OE}$ referred to primary	$TCI_{OE}$	mA/K	-5.22		5.22	
Nominal sensitivity	$S_N$	mV/A		14.375		460 mV @ $I_{PN}$
Sensitivity error	$\epsilon_S$	%	-0.5		0.5	Factory adjustment
Temperature coefficient of $S$	$TCS$	ppm/K	-200		200	
Linearity error 0 ... $I_{PN}$	$\epsilon_L$	% of $I_{PN}$	-0.5		0.5	
Linearity error 0 ... $I_{PM}$	$\epsilon_L$	% of $I_{PM}$	-0.8		0.8	
Magnetic offset current (@ $10 \times I_{PN}$ ) referred to primary	$I_{OM}$	A	-0.25		0.25	
Delay time @ 10 % of the final output value for $I_{PN}$ step	$t_{D10}$	$\mu\text{s}$			2	@ 50 A/ $\mu\text{s}$
Delay time @ 90 % of the final output value for $I_{PN}$ step	$t_{D90}$	$\mu\text{s}$			2.5	@ 50 A/ $\mu\text{s}$
Frequency bandwidth (-3 dB)	$BW$	kHz		450		
Noise voltage spectral density referred to primary 100 Hz ... 100 kHz	$u_{no}$	$\mu\text{V}/\sqrt{\text{Hz}}$			5	
RMS noise voltage referred to primary DC ... 10 kHz DC ... 100 kHz DC ... 1 MHz	$U_{no}$	mVpp		4 10 16		
Sum of sensitivity and linearity @ $I_{PN}$	$\epsilon_{SL}$	% of $I_{PN}$	-1		1	
Sum of sensitivity and linearity @ $I_{PN}$ @ $T_A = +85\text{ °C}$	$\epsilon_{SL85\text{ °C}}$	% of $I_{PN}$	-3.2		3.2	See formula note <sup>1)</sup>
Sum of sensitivity and linearity @ $I_{PN}$ @ $T_A = +105\text{ °C}$	$\epsilon_{SL105\text{ °C}}$	% of $I_{PN}$	-3.9		3.9	See formula note <sup>1)</sup>

Note: <sup>1)</sup>  $\epsilon_{SL}(T_A) = \epsilon_{SL25} + \left( TCS + \frac{TCI_{OE}}{I_{PN}} \right) \times |T_A - 25|$

**Electrical data HLSR 40-SM/SP33**

 At  $T_A = 25\text{ °C}$ ,  $U_C = +3.3\text{ V}$ ,  $R_L = 10\text{ k}\Omega$  unless otherwise noted (see Min, Max, typ, definition paragraph in [page 9](#)).

Parameter	Symbol	Unit	Min	Typ	Max	Comment
Primary nominal RMS current	$I_{PN}$	A		40		
Primary current, measuring range	$I_{PM}$	A	-100		100	For $U_C = +3.3\text{ V} \pm 5\%$
Number of primary turns	$N_P$	-		1		
Resistance of primary jumper @ $T_A = 25\text{ °C}$	$R_P$	m $\Omega$		0.21		
Resistance of primary jumper @ $T_A = 105\text{ °C}$	$R_P$	m $\Omega$		0.29		$T$ jumper = $120\text{ °C}$
Supply voltage	$U_C$	V	3.135	3.3	3.465	
Current consumption	$I_C$	mA		19	25	
Reference voltage (output)	$U_{ref}$	V	1.63	1.65	1.67	Internal reference
Reference voltage (input)	$U_{ref}$	V	0.5		1.7	External reference
Output voltage range @ $I_{PM}$	$U_{out} - U_{ref}$	V	-1.15		1.15	Over operating temperature range
Internal series resistance of reference voltage	$R_{ref}$	$\Omega$	130	200	300	series
Output internal resistance	$R_{out}$	$\Omega$		2	5	series
Load capacitance	$C_L$	nF	0		6	
Electrical offset voltage referred to primary @ $I_P = 0$	$U_{OE}$	mV	-5		5	$U_{out} - U_{ref}$ @ $U_{ref} = 1.65\text{ V}$ Not guaranteed in REF IN mode with external reference $U_{ref} \neq 1.65\text{ V}$
Electrical offset current referred to primary	$I_{OE}$	mA	-435		435	
Temperature coefficient of $U_{ref}$	$TCU_{ref}$	ppm/K	-150		150	$-40\text{ °C} \dots 105\text{ °C}$
Temperature coefficient of $U_{OE}$ referred to primary	$TCU_{OE}$	mV/K	-0.075		0.075	
Temperature coefficient of $I_{OE}$ referred to primary	$TCI_{OE}$	mA/K	-6.52		6.52	
Nominal sensitivity	$S_N$	mV/A		11.5		460 mV @ $I_{PN}$
Sensitivity error	$\epsilon_S$	%	-0.5		0.5	Factory adjustment
Temperature coefficient of $S$	$TCS$	ppm/K	-200		200	
Linearity error 0 ... $I_{PN}$	$\epsilon_L$	% of $I_{PN}$	-0.5		0.5	
Linearity error 0 ... $I_{PM}$	$\epsilon_L$	% of $I_{PM}$	-0.8		0.8	
Magnetic offset current (@ $10 \times I_{PN}$ ) referred to primary	$I_{OM}$	A	-0.25		0.25	
Delay time @ 10 % of the final output value for $I_{PN}$ step	$t_{D10}$	$\mu\text{s}$			2	@ 50 A/ $\mu\text{s}$
Delay time @ 90 % of the final output value for $I_{PN}$ step	$t_{D90}$	$\mu\text{s}$			2.5	@ 50 A/ $\mu\text{s}$
Frequency bandwidth (-3 dB)	$BW$	kHz		450		
Noise voltage spectral density referred to primary 100 Hz ... 100 kHz	$u_{no}$	$\mu\text{V}/\sqrt{\text{Hz}}$			4.5	
RMS noise voltage referred to primary DC ... 10 kHz DC ... 100 kHz DC ... 1 MHz	$U_{no}$	mVpp		4 9 14		
Sum of sensitivity and linearity @ $I_{PN}$	$\epsilon_{SL}$	% of $I_{PN}$	-1		1	
Sum of sensitivity and linearity @ $I_{PN}$ @ $T_A = +85\text{ °C}$	$\epsilon_{SL85\text{ °C}}$	% of $I_{PN}$	-3.2		3.2	See formula note <sup>1)</sup>
Sum of sensitivity and linearity @ $I_{PN}$ @ $T_A = +105\text{ °C}$	$\epsilon_{SL105\text{ °C}}$	% of $I_{PN}$	-3.9		3.9	See formula note <sup>1)</sup>

Note: <sup>1)</sup>  $\epsilon_{SL}(T_A) = \epsilon_{SL25} + \left( TCS + \frac{TCI_{OE}}{I_{PN}} \right) \times |T_A - 25|$

**Electrical data HLSR 50-SM/SP33**

 At  $T_A = 25\text{ °C}$ ,  $U_C = +3.3\text{ V}$ ,  $R_L = 10\text{ k}\Omega$  unless otherwise noted (see Min, Max, typ, definition paragraph in [page 9](#)).

Parameter	Symbol	Unit	Min	Typ	Max	Comment
Primary nominal RMS current	$I_{PN}$	A		50		
Primary current, measuring range	$I_{PM}$	A	-125		125	For $U_C = +3.3\text{ V} \pm 5\%$
Number of primary turns	$N_P$	-		1		
Resistance of primary jumper @ $T_A = 25\text{ °C}$	$R_P$	m $\Omega$		0.21		
Resistance of primary jumper @ $T_A = 105\text{ °C}$	$R_P$	m $\Omega$		0.29		$T_{\text{jumper}} = 120\text{ °C}$
Supply voltage <sup>1)</sup>	$U_C$	V	3.135	3.3	3.465	
Current consumption	$I_C$	mA		19	25	
Reference voltage (output)	$U_{ref}$	V	1.63	1.65	1.67	Internal reference
Reference voltage (input)	$U_{ref}$	V	0.5		1.7	External reference
Output voltage range @ $I_{PM}$	$U_{out} - U_{ref}$	V	-1.15		1.15	Over operating temperature range
Internal series resistance of reference voltage	$R_{ref}$	$\Omega$	130	200	300	series
Output internal resistance	$R_{out}$	$\Omega$		2	5	series
Load capacitance	$C_L$	nF	0		6	
Electrical offset voltage referred to primary @ $I_P = 0$	$U_{OE}$	mV	-5		5	$U_{out} - U_{ref}$ @ $U_{ref} = 1.65\text{ V}$ Not guaranteed in REF IN mode with external reference $U_{ref} \neq 1.65\text{ V}$
Electrical offset current referred to primary	$I_{OE}$	mA	-543		543	
Temperature coefficient of $U_{ref}$	$TCU_{ref}$	ppm/K	-150		150	-40 °C ... 105 °C
Temperature coefficient of $U_{OE}$ referred to primary	$TCU_{OE}$	mV/K	-0.075		0.075	
Temperature coefficient of $I_{OE}$ referred to primary	$TCI_{OE}$	mA/K	-8.15		8.15	
Nominal sensitivity	$S_N$	mV/A		9.2		460 mV @ $I_{PN}$
Sensitivity error	$\epsilon_S$	%	-0.5		0.5	Factory adjustment
Temperature coefficient of $S$	$TCS$	ppm/K	-200		200	
Linearity error 0 ... $I_{PN}$	$\epsilon_L$	% of $I_{PN}$	-0.5		0.5	
Linearity error 0 ... $I_{PM}$	$\epsilon_L$	% of $I_{PM}$	-0.8		0.8	
Magnetic offset current (@ $10 \times I_{PN}$ ) referred to primary	$I_{OM}$	A	-0.25		0.25	
Delay time @ 10 % of the final output value for $I_{PN}$ step	$t_{D10}$	$\mu\text{s}$			2	@ 50 A/ $\mu\text{s}$
Delay time @ 90 % of the final output value for $I_{PN}$ step	$t_{D90}$	$\mu\text{s}$			2.5	@ 50 A/ $\mu\text{s}$
Frequency bandwidth (-3 dB)	$BW$	kHz		450		
Noise voltage spectral density referred to primary 100 Hz ... 100 kHz	$u_{no}$	$\mu\text{V}/\sqrt{\text{Hz}}$			4	
RMS noise voltage referred to primary DC ... 10 kHz DC ... 100 kHz DC ... 1 MHz	$U_{no}$	mVpp		3.3 7.3 12		
Sum of sensitivity and linearity @ $I_{PN}$	$\epsilon_{SL}$	% of $I_{PN}$	-1		1	
Sum of sensitivity and linearity @ $I_{PN}$ @ $T_A = +85\text{ °C}$	$\epsilon_{SL85\text{ °C}}$	% of $I_{PN}$	-3.2		3.2	See formula note <sup>1)</sup>
Sum of sensitivity and linearity @ $I_{PN}$ @ $T_A = +105\text{ °C}$	$\epsilon_{SL105\text{ °C}}$	% of $I_{PN}$	-3.9		3.9	See formula note <sup>1)</sup>

Note: <sup>1)</sup>  $\epsilon_{SL}(T_A) = \epsilon_{SL25} + \left( TCS + \frac{TCI_{OE}}{I_{PN}} \right) \times |T_A - 25|$



Maximum continuous DC current

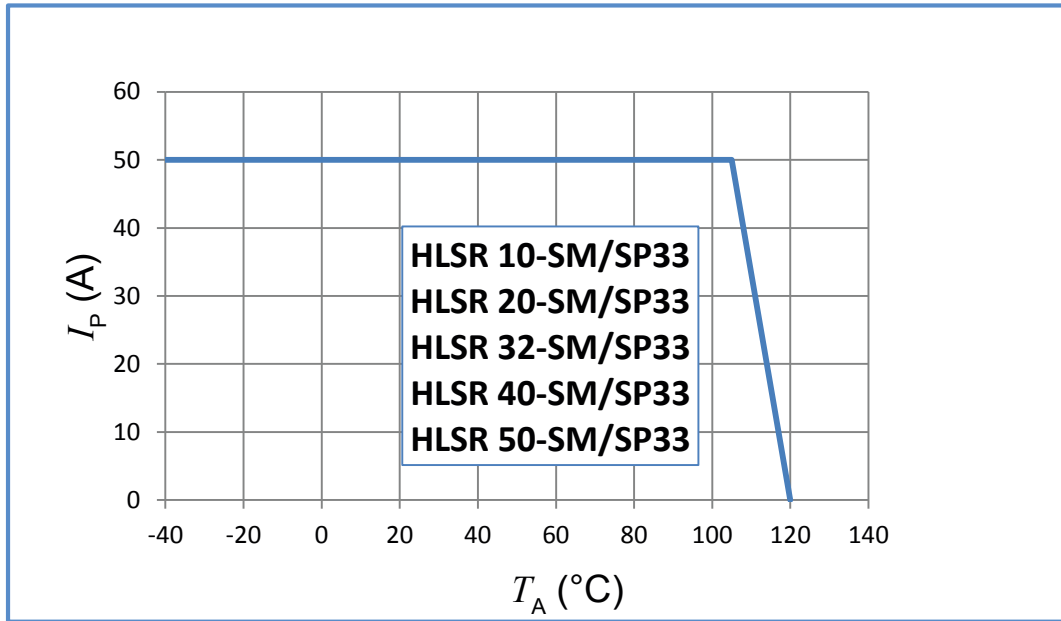

**Important notice:** whatever the usage and/or application, the transducer jumper temperature shall not go above the maximum ratings of 120 °C as stated in page 2 of this datasheet.

Definition of typical, minimum and maximum values

Minimum and maximum values for specified limiting and safety conditions have to be understood as such as well as values shown in “typical” graphs.

On the other hand, measured values are part of a statistical distribution that can be specified by an interval with upper and lower limits and a probability for measured values to lie within this interval.

Unless otherwise stated (e.g. “100 % tested”), the LEM definition for such intervals designated with “min” and “max” is that the probability for values of samples to lie in this interval is 99.73 %.

For a normal (Gaussian) distribution, this corresponds to an interval between -3 sigma and +3 sigma. If “typical” values are not obviously mean or average values, those values are defined to delimit intervals with a probability of 68.27 %, corresponding to an interval between -sigma and +sigma for a normal distribution.

Typical, minimum and maximum values are determined during the initial characterization of the product.

Measuring range versus external reference voltage

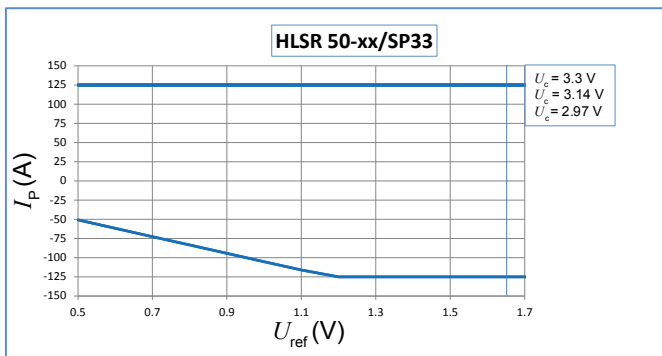
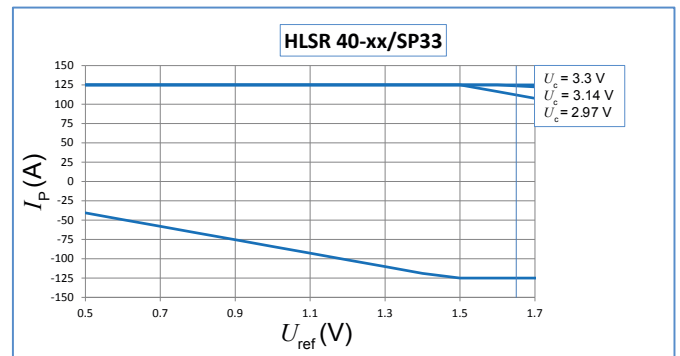
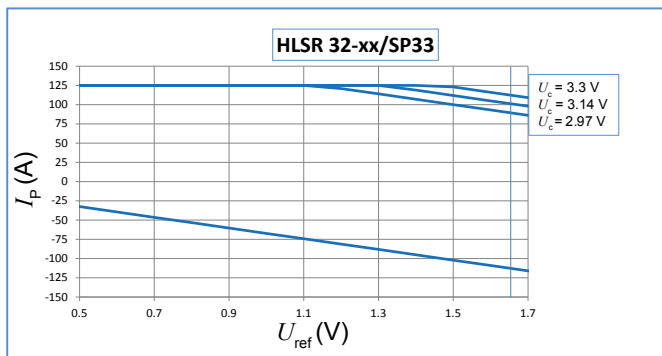
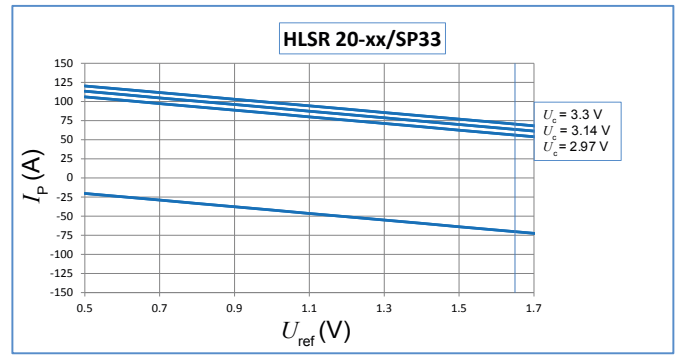
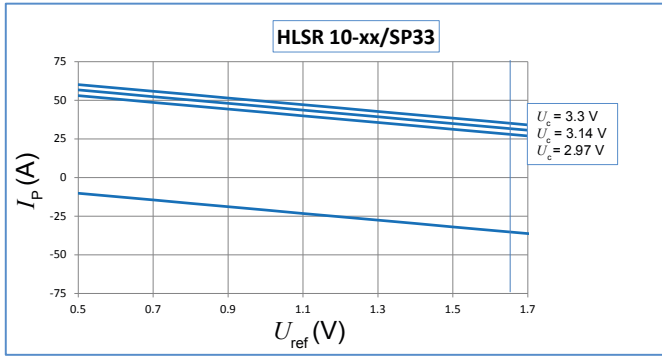

PCB footprint (in mm)

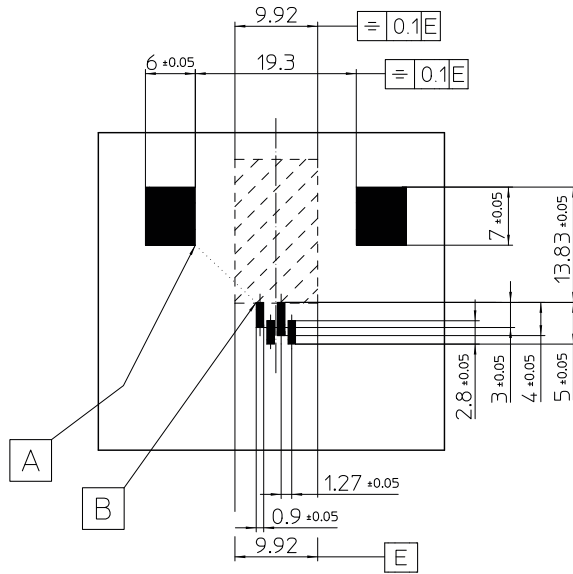

Recommended PCB layout based on a stencil thickness of 150µm (.006 inch)

	$d_{Cl}$ (mm)	$d_{Cp}$ (mm)
A-B	10	10

Assembly on PCB

- Pb free reflow profile
- No clean process only

Safety

This transducer must be used in limited-energy secondary circuits according to IEC 61010-1.



This transducer must be used in electric/electronic equipment with respect to applicable standards and safety requirements in accordance with the manufacturer's operating instructions.



Caution, risk of electrical shock.

When operating the transducer, certain parts of the module can carry hazardous voltage (eg. primary busbar, power supply). Ignoring this warning can lead to injury and/or cause serious damage. This transducer is a build-in device, whose conducting parts must be inaccessible after installation. A protective housing or additional shield could be used. Main supply must be able to be disconnected.

