

PRODUCT SPECIFICATION

DATE OF ISSUED : March 15, 2001

DATA	REVISION RECORD	MARK	DRAWING BY	CHECKED BY	APPROVED BY
BUSINESS SECTION		ENGINEERING SECTION			SPECIFICATION NO.
CHECKED BY	APPROVED BY	REPORTED BY	CHECKED BY	APPROVED BY	

PRODUCT SPECIFICATION

1. SCOPE:

This specification applies to the MULTILAYER CHIP IMPEDER ARRAY (MZA3216Type) delivered to _____

2. PART NUMBER:

•Part numbers description : Refer to page 3.

3. OUTLINE DRAWING AND DIMENSION:

•Outline drawing : Refer to page 2.
•Dimensions : Refer to page 2.

4. ELECTRICAL CHARACTERISTICS:

•Electrical characteristics : Refer to page 3.

5. MEASUREMENT METHODS:

•Measurement methods and conditions : Refer to page 4 and page5.
•Measuring condition : Unless otherwise specified, measurement should be performed at 5~35°C and 45~85% RH. However, for referee purpose at 20±2°C and 60~70% RH.

6. RELIABILITY TEST:

•Reliability test : Refer to page 6 through page 9.

7. PACKING AND PACKAGING:

•Tape and reel packaging : Refer to page 10 and page 11.
•Package the product in a manner which protects against moisture and mechanical shock. The labels will contain the following information.
•Customer name
•Customer part number
•TDK item
•TDK item code
•Inspection number
•Remarks
•Quantity
•TDK logo

8. OTHERS:

•Caution when handling : Refer to page 12.

3. OUTLINE DRAWING AND DIMENSIONS:

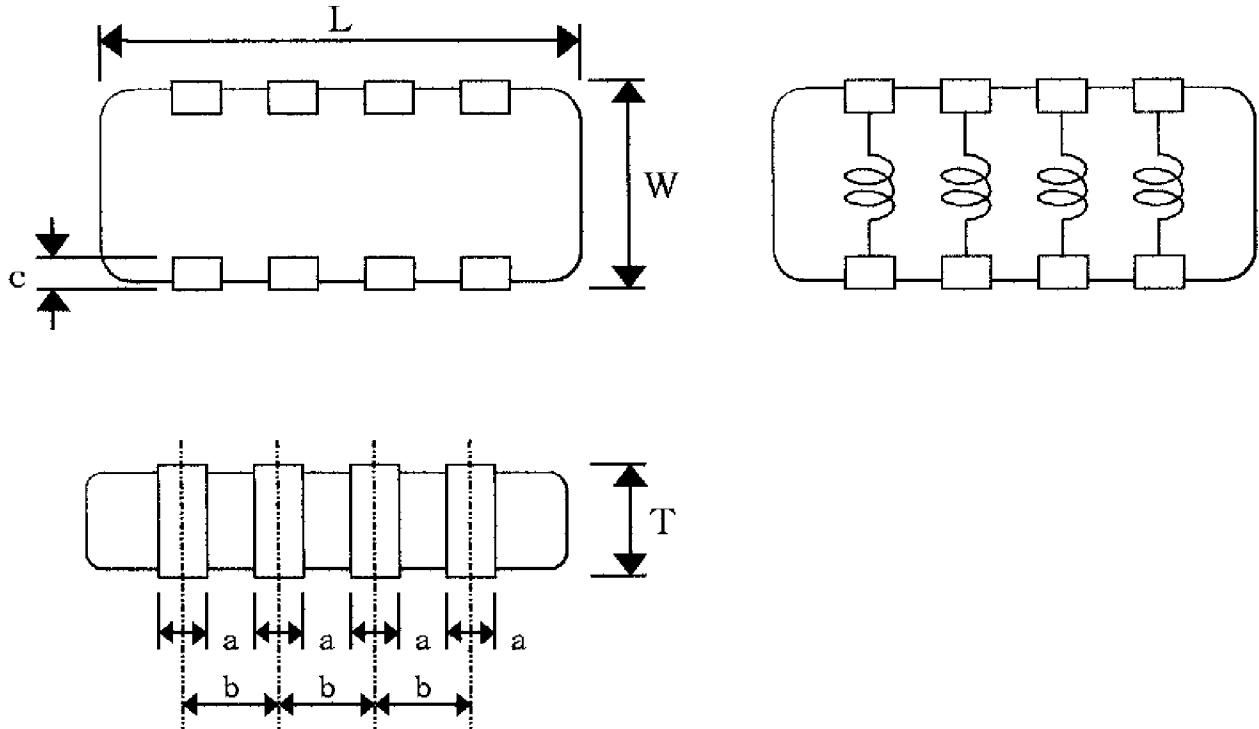

[Figure-1]

[Table-1]

Unit : mm

TYPE	Mechanical dimensions					
	L	W	T	a	b	c
MZA3216	3.2 ± 0.2	1.6 ± 0.2	0.8 ± 0.2	0.4 ± 0.15	0.8 ± 0.1	0.15 以上

[Figure-2]

Ferrite
 Internal electrode (Ag)
 Pull out electrode (Ag)
 Terminal electrode : Inside(Ag)
 Terminal electrode :
 Outside(Electro-plating)

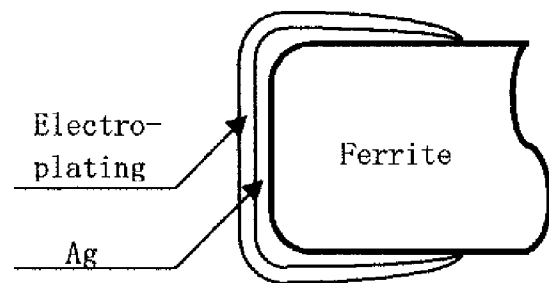

4. ELECTRICAL CHARACTERISTICS:

4.1 Electrical characteristics

[Table - 2]

P#	Item	Impedance	$R_{DC} (\Omega)$	$I_{DC} (mA)$	
		100MHz, (Ω)	MAX	MAX	
	MZA3216R121AT	$120 \pm 25\%$	0.20	150	
	MZA3216R301AT	$300 \pm 25\%$	0.40	100	
	MZA3216R601AT	$600 \pm 25\%$	0.60	100	
	MZA3216R102AT	$1000 \pm 25\%$	0.80	50	
	MZA3216Y121BT	$120 \pm 25\%$	0.25	150	
	MZA3216Y301BT	$300 \pm 25\%$	0.40	100	
	MZA3216Y601BT	$600 \pm 25\%$	0.60	100	
	MZA3216Y102BT	$1000 \pm 25\%$	0.80	50	

4.2 Electrical characteristics

Temperature Normal temperature (5~35°C)

Relative humidity Normal humidity (45~85%)

Standard measurement conditions are above stated, if abnormal situation happened, it's measured following conditions.

Temperature $20 \pm 2^\circ\text{C}$

Relative humidity 60~70%

TEST METHOD	SPEC. NO. N00UZ-092	P4
-------------	------------------------	----

5. TEST METHOD:

5.1 Impedance

5.1.1 Test equipment and test fixture

Test equipment : Impedance analyzer 4195A(HP)
 Test fixture : 16092A

Remarks : In case of measure the frequency characteristics over 1GHz,
 use following instruments.

Test equipment : Impedance analyzer 4291A(HP)
 Test fixture : 16193A

5.1.2 Test method

Set the measurement frequency , and put a specimen in test fixture ,
 and read the frequency.

5.2 Direct-Current of Resistance (R_{DC})

5.2.1 Measurement circuit

[Figure-3]

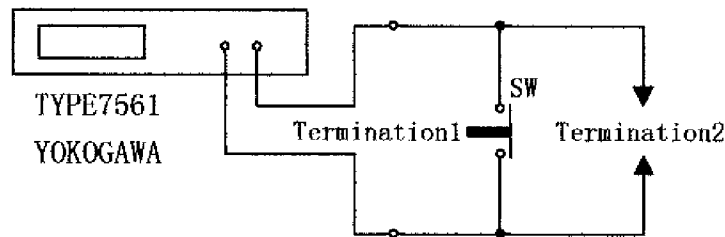

5.2.2 Test Method

- 1) Connect milli-ohm meter TYPE7561 across Termination 1.
- 2) Put a specimen in Termination 2.
- 3) Read the R_{DC} value during the switch is off.

Remarks: Never to take in and out a specimen in the
 Termination 2 while switch is off.

5.3 Rated current

5.3.1 Measurement circuit

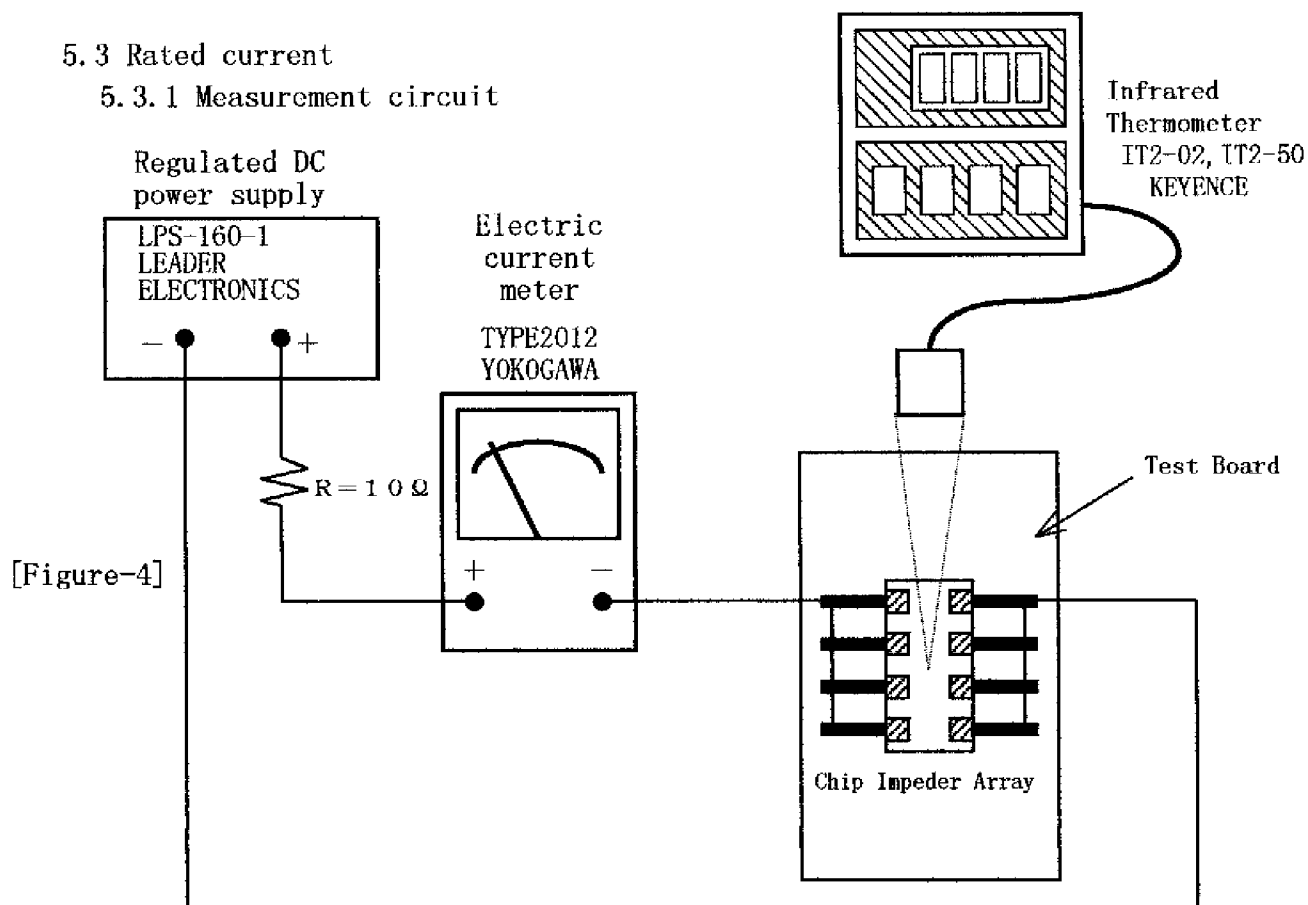

5.3.2 Test Method

- 1) Solder specimen impeder on the printed circuit board in appended Figure-8.
- 2) Set test current to be 0 mA.
- 3) Measure initial value of chip surface temperature.
- 4) Gradually increase voltage, and measure chip surface temperature for corresponding current.

5.3.3 Definition of I. d. c.

Definition of I. d. c. is direct electric current as chip surface temperature rose just 5°C against chip surface temperature.

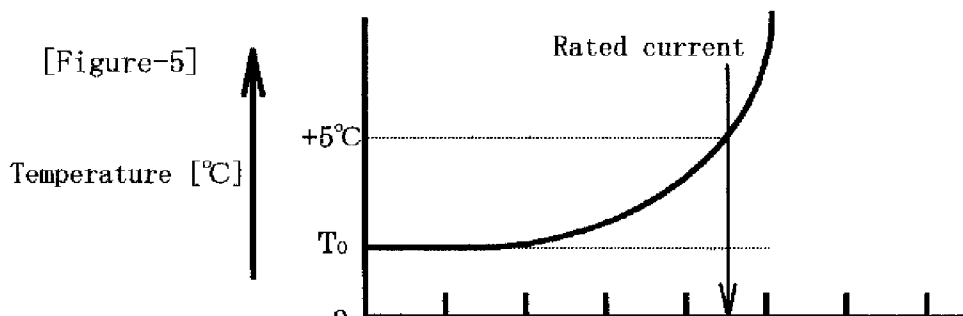

6. RELIABILITY TEST

[Table-3]

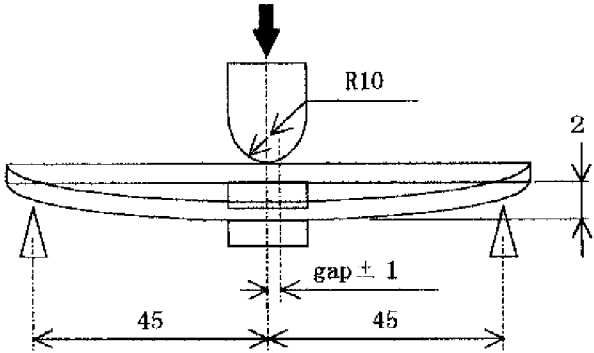
NO.	Item	Specification	Test method
6.1	Bending test	No mechanical damage.	<p>Solder specimen impeder on the test printed circuit board in appended Figure-8. Apply the load in direction of the arrow until the bending reaches 2mm. (See Figure-6)</p>  <p>[Figure-6] Unit : mm</p>
6.2	Vibration test	No mechanical damage. Impedance Variation to be within $\pm 20\%$	<p>Apply vibrations in each of the x, y and z directions for 2 hours for a total of 6 hours.</p> <p>Frequency : 10~55~10Hz</p> <p>Total amplitude : 1.5mm</p> <p>Sweep time : 1 min</p>
6.3	Drop test	No mechanical damage. Impedance Variation to be within $\pm 20\%$	<p>Drop soldered specimen impeder 10 times from a height of 1 meter.</p>
6.4	Humidity test (Steady state)	No mechanical damage. Impedance Variation to be within $\pm 20\%$	<p>Leave the specimen impeder at $60 \pm 2^\circ\text{C}$ and 90 to 95%RH for 500 ± 12 hours.</p> <p>Measure the test items after leaving them in normal temperature and humidity for 1 to 2 hours.</p>
6.5	Life test	No mechanical damage. Impedance Variation to be within $\pm 20\%$	<p>Leave the specimen impeder at $85 \pm 2^\circ\text{C}$ for 500 ± 12 hours.</p> <p>Measure the test items after leaving them in normal temperature and humidity for 1 to 2 hours.</p>

[Table-3] Continue

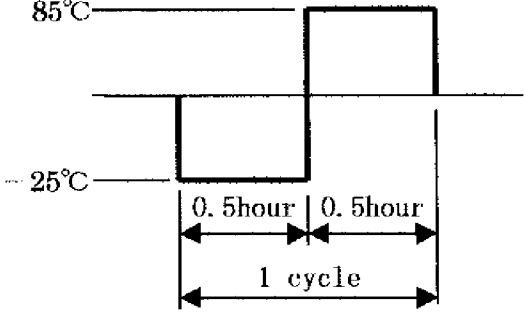
NO.	Item	Specification	Test method
6.6	Cold test	No mechanical damage. Impedance Variation to be within $\pm 20\%$	Leave the specimen impeder at $40 \pm 2^\circ\text{C}$ for 500 ± 12 hours. Measure the test items after leaving them in normal temperature and humidity for 1 to 2 hours.
6.7	Temperature cycling test	No mechanical damage. Impedance Variation to be within $\pm 20\%$	Solder specimen impeder on the test printed circuit board in appended Figure-9, then go through 100 cycles under the following conditions. [Figure-7]  85°C - 25°C 0.5hour 0.5hour 1 cycle
6.8	Resistance to soldering test	No mechanical damage. Terminal electrodes should remain over than 90% Impedance variation to be within $\pm 30\%$	After flux application and preheat for 2 to 3 minutes at 150°C to 180°C , then dip in solder at $260 \pm 5^\circ\text{C}$ for 10 ± 0.5 seconds. Flux : Isopropyl alcohol (JIS-K-8839) Solder : JIS-Z-3282 H63A
6.9	Solserbility	The terminal electrodes should be covered by new solder over than 90%	After flux application and preheat for 2 to 3 minutes at 150°C to 180°C , then dip in solder at $230 \pm 5^\circ\text{C}$ for 4 ± 1 seconds. Flux : Rosin (JIS-K-5902) dissolved in Isopropyl Alcohol (JIS-K-8839) at the weight rate of 25% Solder : JIS-Z-3282 H63A

TEST P. C BOARD

[Figure-8]

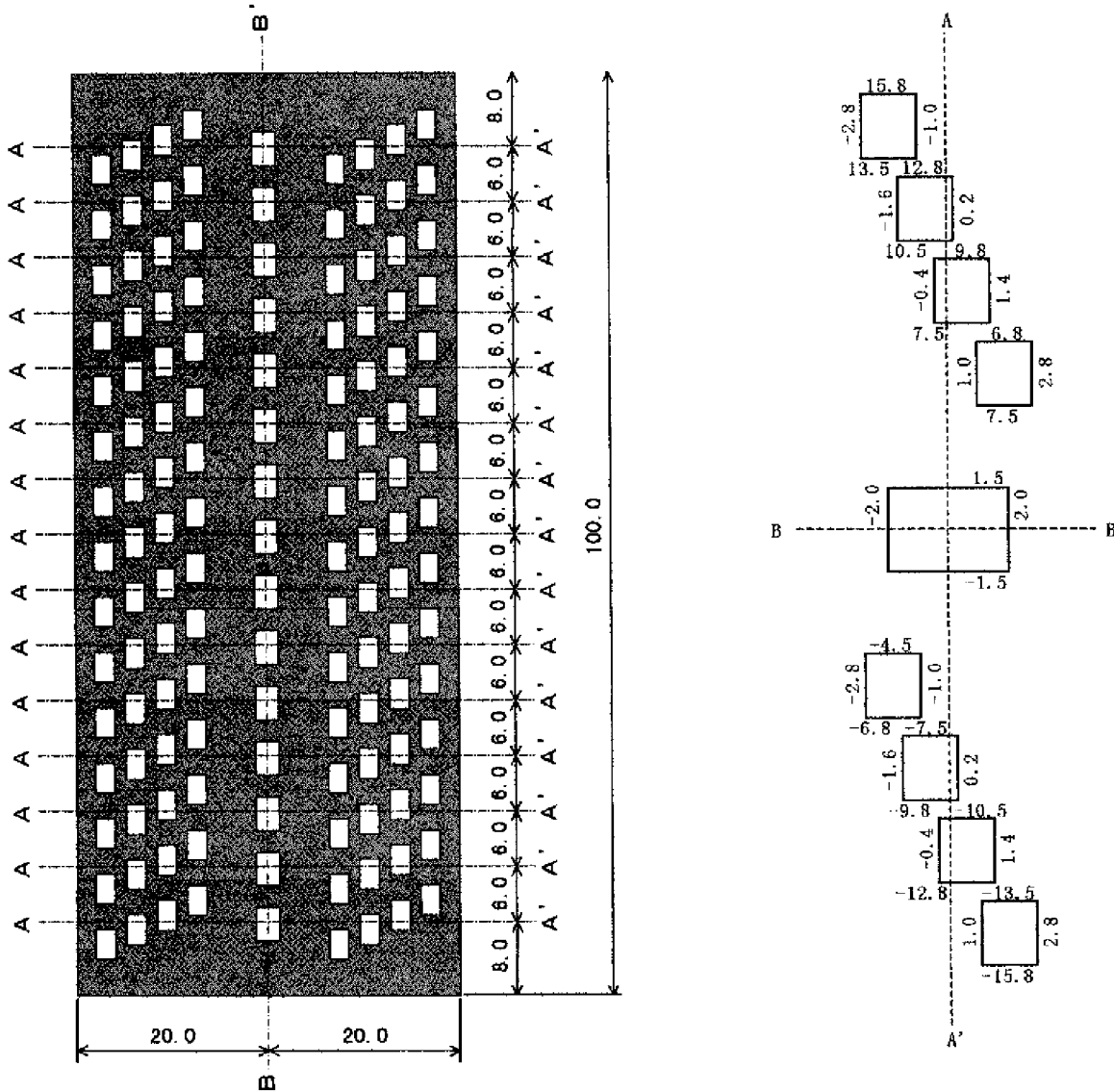

Unit : mm

1. Applicable specification : JPCA.

2. Material

Glass epoxy resin (G-10) : JIS-C-6485

3. Thickness $t = 0.8\text{mm}$

4. Treatment

The shaded portion of printed circuit board is covered with solder resist FLUX (ASAHI NO. 22).

TEST P. C BOARD

[Figure-9]

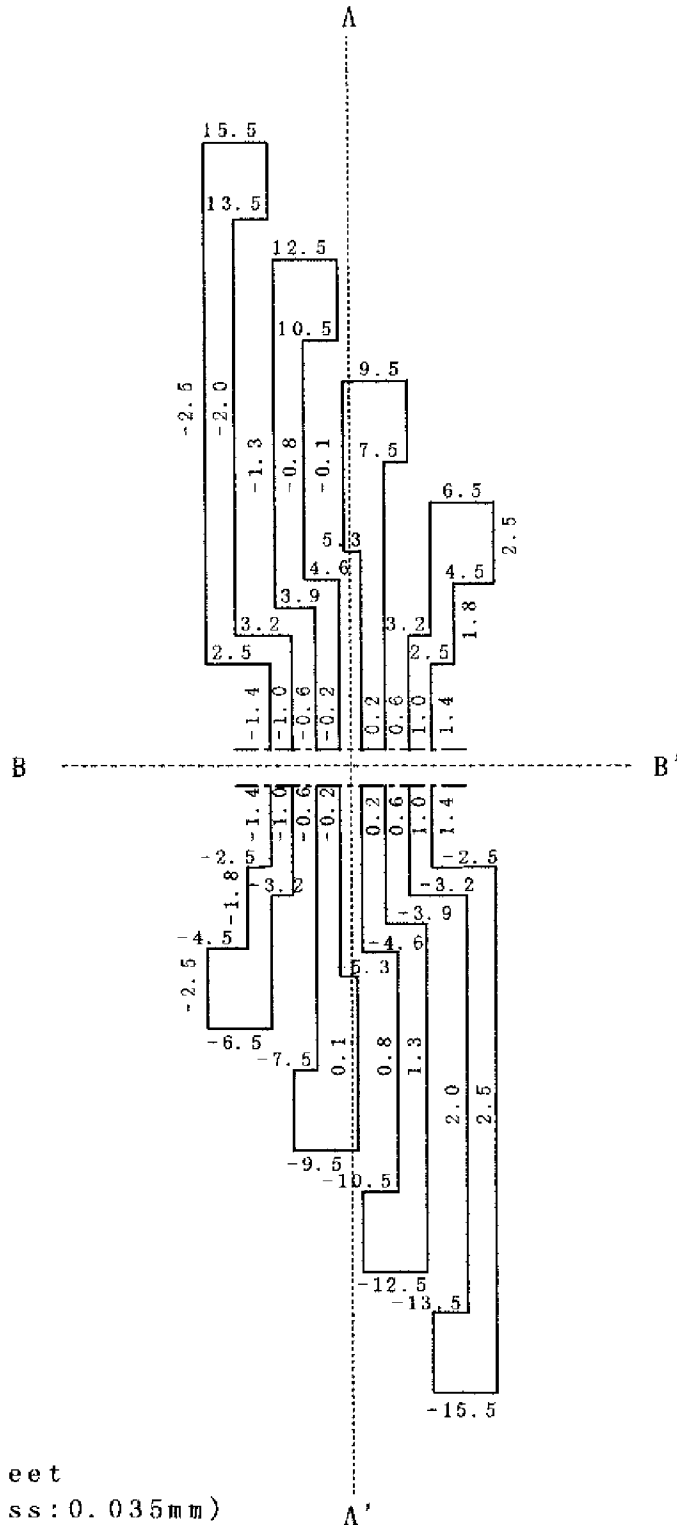

Copper sheet
(Thickness: 0.035mm)

Unit : mm

7. PACKING AND PACKAGING

7.1 Tape and Reel packaging

7.1.1 Reel dimensions and label

[Figure-10]

* Shaded portion is hole

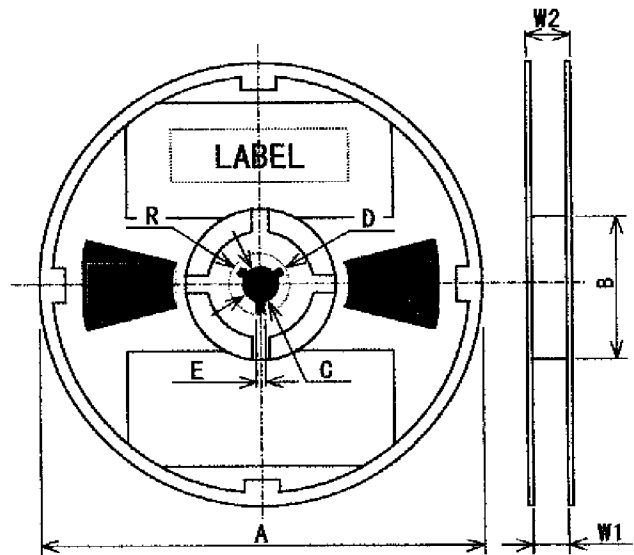

[Table-4]

(Unit : mm)

Type	A	B	C	D	E	W1	W2	R
3216	$\phi 178 \pm 2.0$	$\phi 60 \pm 2.0$	$\phi 13 \pm 0.5$	$\phi 21 \pm 0.8$	2.0 ± 0.5	9 ± 0.3	13 ± 1.4	1.0

7.1.2 Tape dimensions and material

[Figure-11]

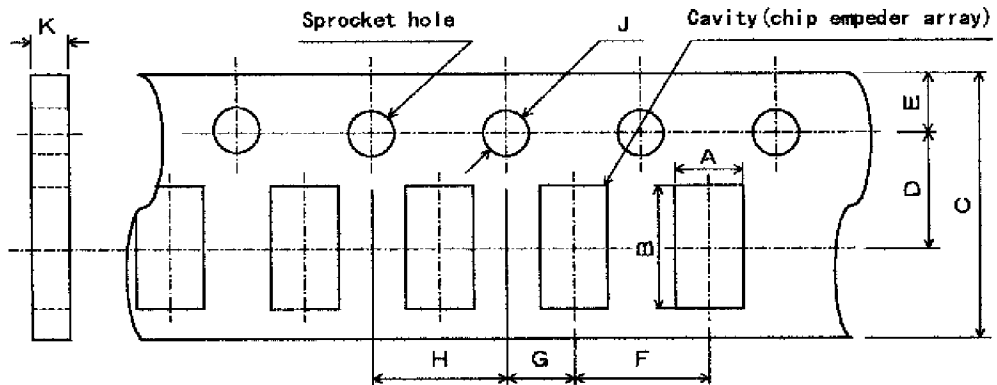

Tape dimensions [Table-5]

Type	A	B	C	D	E	F	G	H
3216	2.0 ± 0.2	3.6 ± 0.2	8.0 ± 0.3	3.5 ± 0.05	1.75 ± 0.1	4.0 ± 0.1	2.0 ± 0.05	4.0 ± 0.1
Type	J	K						
3216	1.5 ± 0.1 -0.0	1.1 MAX						

Carrier tape material : Paper

7.1.3 Shape of Packing

[Figure-12]

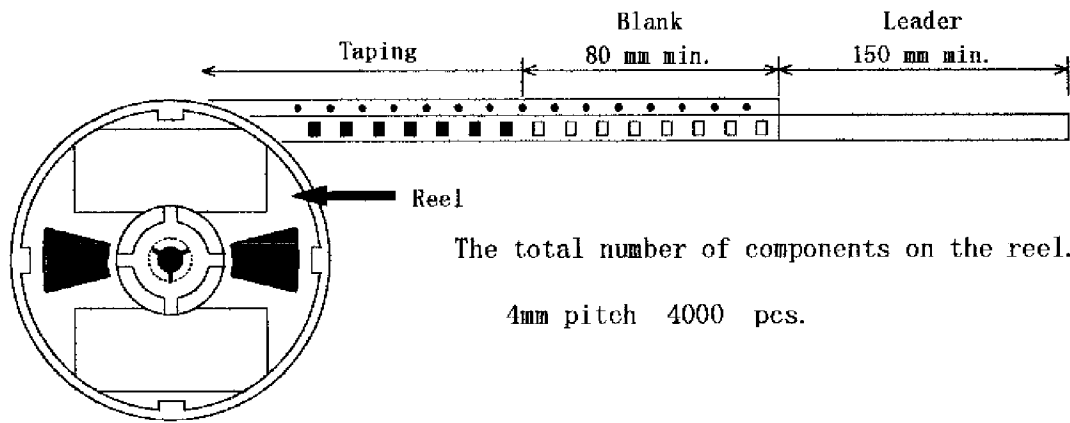

The total number of components on the reel.

4mm pitch 4000 pcs.

8. OTHERS

8.1 Operating temperature range

-25°C ~ +85°C

8.2 Storage temperature range

-40°C ~ +85°C

8.3 Humidity range

0~90%RH (The least upper temperature is 38°C)

8.4 Illustration of parts name

MZA 3 2 1 6 Y 1 0 2 B ○ △△△
(1) (2) (3) (4) (5) (6) (7)

- (1) Multilayer chip impeder
- (2) Dimension (3.2mm×1.6mm)
- (3) Material name
- (4) Impedance (102 : 1000 Ω)
- (5) Type of frequency characteristic
- (6) Package type (T : Taping)
- (7) Control number

8.5 Caution when handling

8.5.1 Preheating process before soldering is required.

Preheat the components so that the temperature difference between MZA and soldering temperature should be kept within 150°C

8.5.2 MZA should be handled with care not to apply mechanical force by bending P.C. board on which MZA are mounted.

8.5.3 Do not use MZA over rated electric current.

8.5.4 WRIST-STRAP for preventing static electricity should be used.

8.5.5 Do not use magnet near by MZA.

8.5.6 Recommended retouch condition by iron.

Retouch condition by iron is less than 300°C, Within 3 sec.