

THIS DRAWING IS UNPUBLISHED.

RELEASED FOR PUBLICATION

ALL RIGHTS RESERVED.

© COPYRIGHT - By -

LOC  
AF

DIST  
50

REVISIONS

| P | LTR | DESCRIPTION               | DATE      | DWN | APVD |
|---|-----|---------------------------|-----------|-----|------|
|   | L1  | REVISED PER ECO-14-013052 | 22AUG2014 | NK  | DC   |

1 CONTINUOUS STRIP ON REELS.

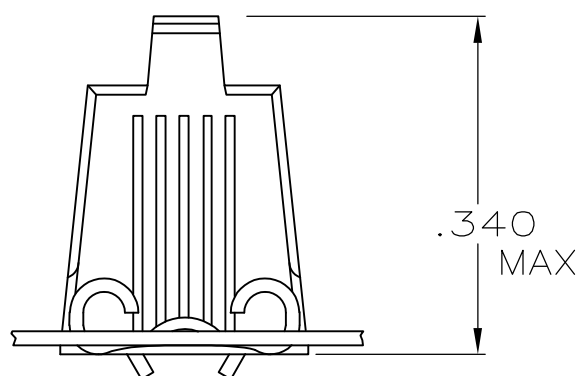
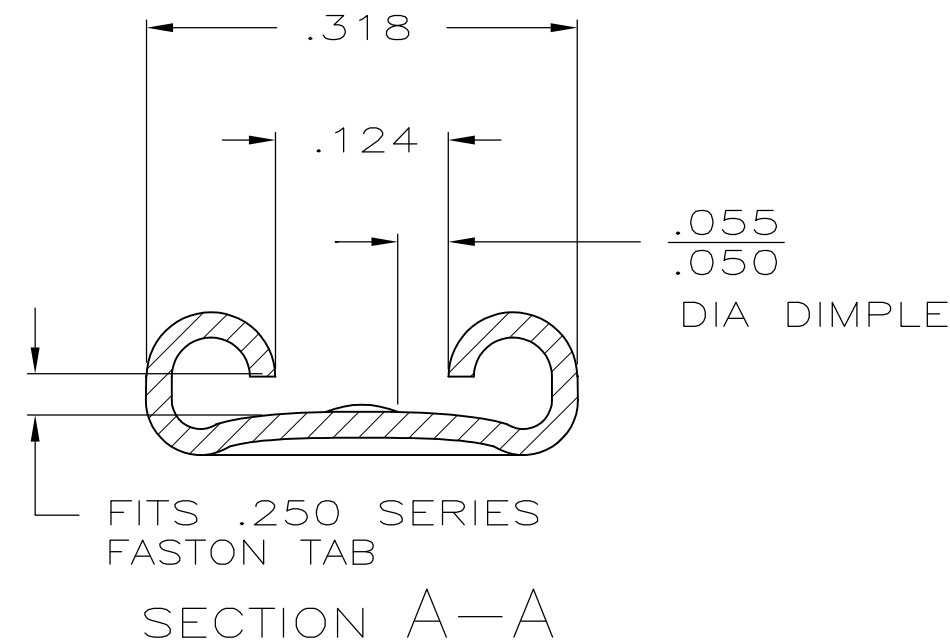
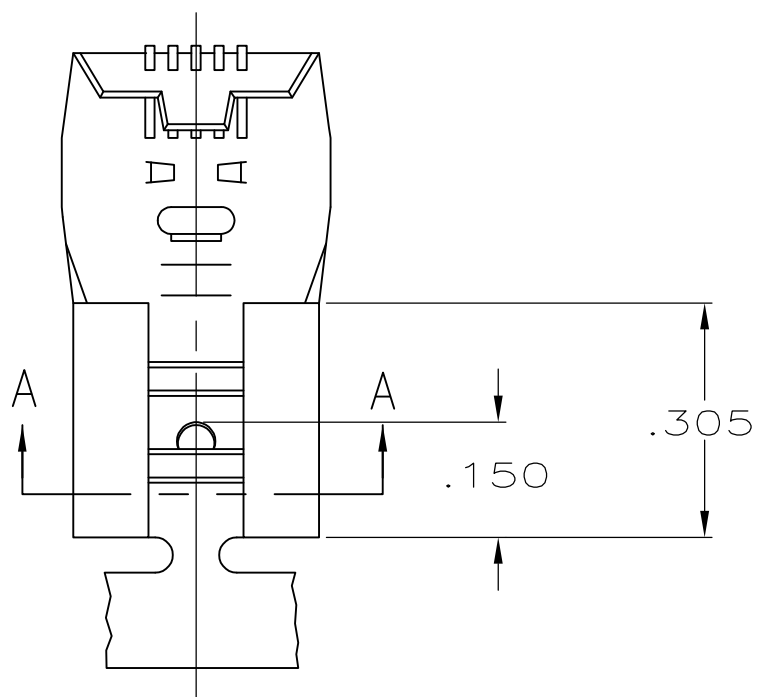

|          |                  |                      |        |                       |                    |
|----------|------------------|----------------------|--------|-----------------------|--------------------|
|          | 18-12            | .032±.001            | TIN    | BRASS                 | 62021-3            |
| OBSOLETE | <del>18-12</del> | <del>.032±.001</del> |        | <del>.018 BRASS</del> | <del>62021-2</del> |
| OBSOLETE | <del>18-12</del> | <del>.032±.001</del> | SILVER | .018 PHOS. BRONZE     | 62021-1            |
|          | WIRE SIZE        | TAB THK              | FINISH | MATERIAL              | PART NO            |

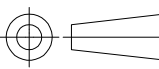
|   |  |                            |  |                 |            |               |   |
|---|--|----------------------------|--|-----------------|------------|---------------|---|
| THIS DRAWING IS A CONTROLLED DOCUMENT.  |  | DWN<br>JR RUTH<br>2/3/86   |  <b>TE Connectivity</b><br>NAME<br>.250 SERIES FLAG FASTON RECEPTACLE |                 |            |               |   |
| DIMENSIONS: INCHES  |  | CHK<br>M FEHER<br>2/6/86   |  |                 |            |               |   |
|  |  | APVD<br>C MEYERS<br>2/7/86 |  |                 |            |               |   |
| TOLERANCES UNLESS OTHERWISE SPECIFIED:  |  | PRODUCT SPEC               |  |                 |            |               |   |
| 0 PLC ± -<br>1 PLC ± -<br>2 PLC ± -<br>3 PLC ± .015<br>4 PLC ± -<br>ANGLES ± -        |  | APPLICATION SPEC           | SIZE   | CAGE CODE       | DRAWING NO | RESTRICTED TO |   |
| MATERIAL<br>SEE TABLE   |  | FINISH<br>SEE TABLE        | WEIGHT<br>-  | A3              | 00779      | C-62021       | - |
| CUSTOMER DRAWING  |  |                            | SCALE<br>NTS   | SHEET<br>1 OF 1 | REV<br>L1  |               |   |