

THIS DRAWING IS UNPUBLISHED. RELEASED FOR PUBLICATION
 © COPYRIGHT - ALL RIGHTS RESERVED.

LOC		DIST		REVISIONS			
P	LTR	DESCRIPTION	DATE	DWN	APVD		
AP	-						
D1		REVISED DRAWING ECO-14-014682	30SEP2014	NCL	DAO		
D2		REVISED DRAWING ECO-14-019131	05JAN2015	NCL	NMS		
D3		REVISED DRAWING ECO-16-006926	06MAY2016	NCL	NMS		
D4		REVISED DRAWING ECO-18-008340	29MAY2018	NMS	JMM		

creo
 Creo Parametric 2.0
DO NOT REVISE
EXCEPT BY CAD

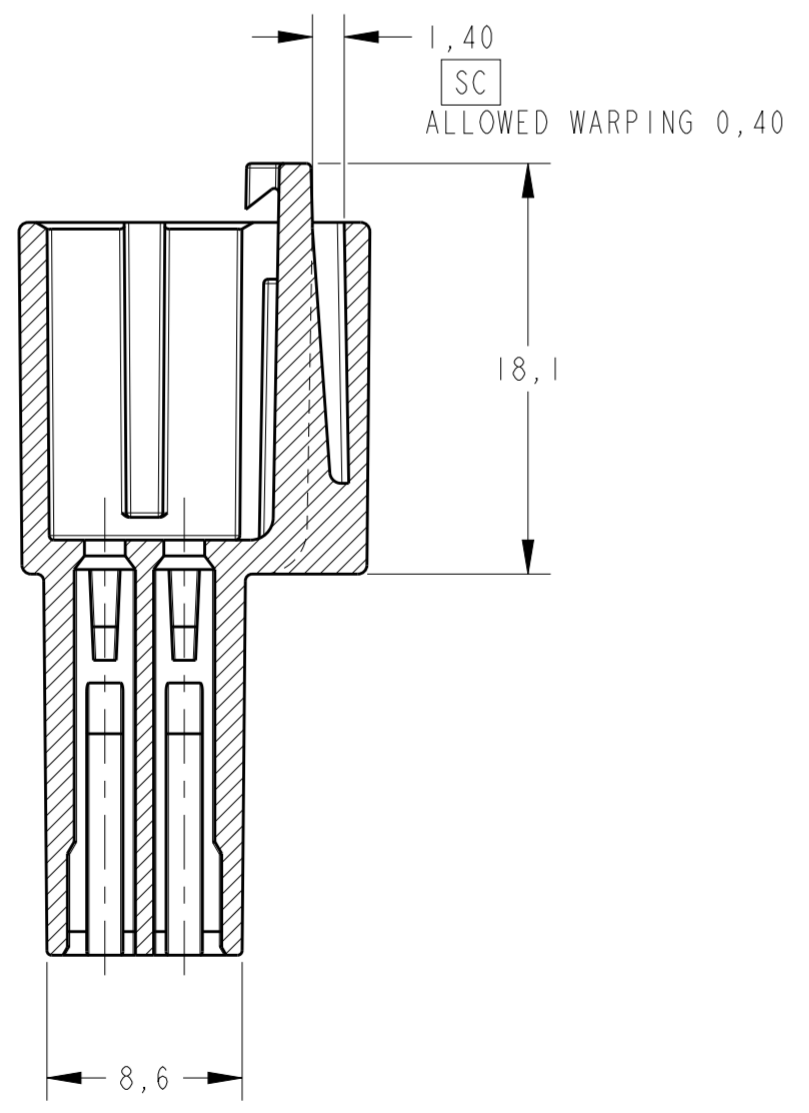
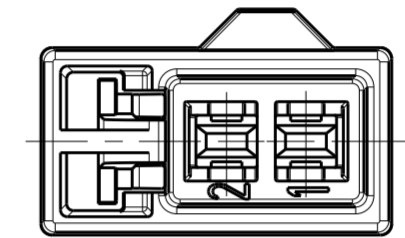
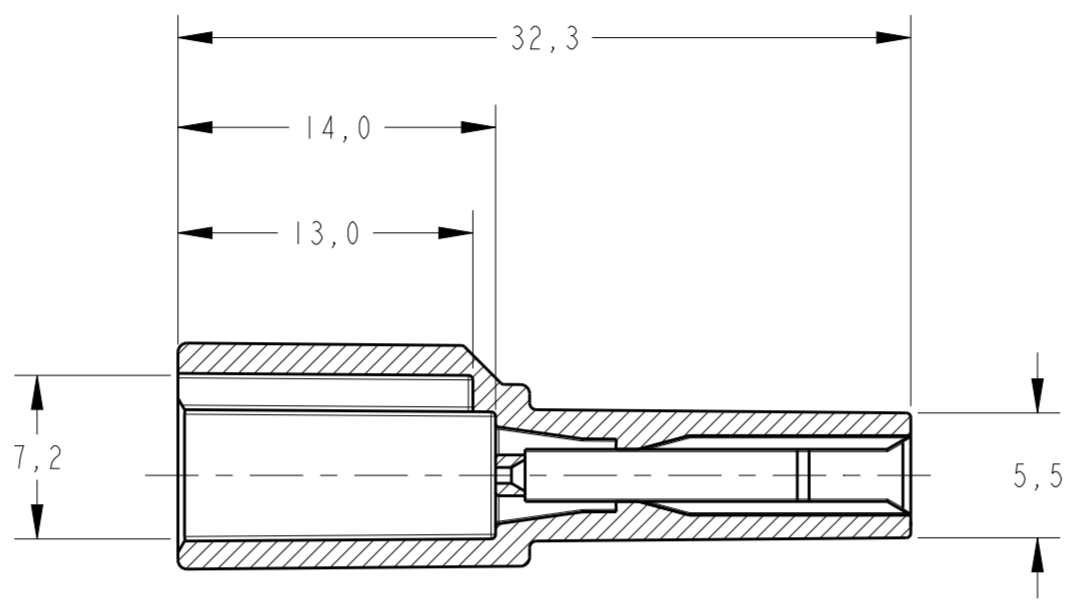
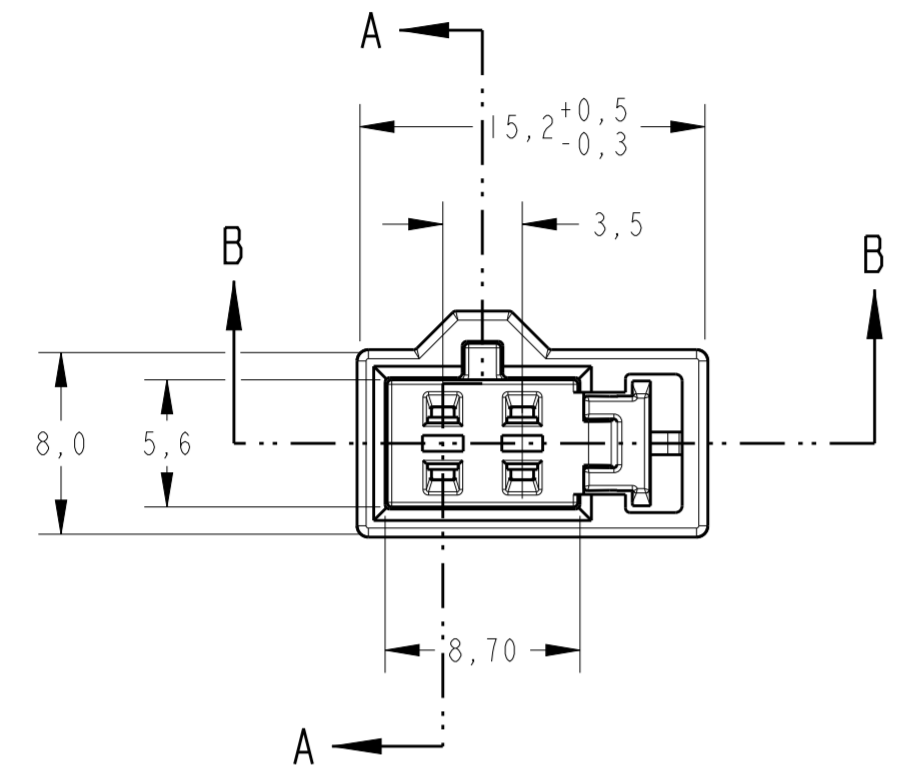

I -SC - CARACTERÍSTICA SIGNIFICATIVA, CONFORME TE 102-37072.
 CC - CARACTERÍSTICA CRÍTICA, CONFORME TE 102-37072.

I -SC - SIGNIFICANT CHARACTERISTIC, ACCORDING TO TE 102-37072.
 CC - CRITICAL CHARACTERISTIC, ACCORDING TO TE 102-37072.

GRAVAÇÃO MARKING
LOGOTIPO AMP AMP LOGO
CÓDIGO PAÍS PRODUTOR MANUFACTURER COUNTRY CODE
NOMENCLATURA MATERIAL MATERIAL NOMENCLATURE
NÚMERO COMPONENTE TE TE COMPONENT NUMBER
NÚMERO CAVIDADE CAVITY NUMBER
IDENTIFICAÇÃO CIRCUITO CIRCUIT IDENTIFICATION
LOGOTIPO VW VW LOGO
NÚMERO PEÇA CLIENTE CUSTOMER PART NUMBER

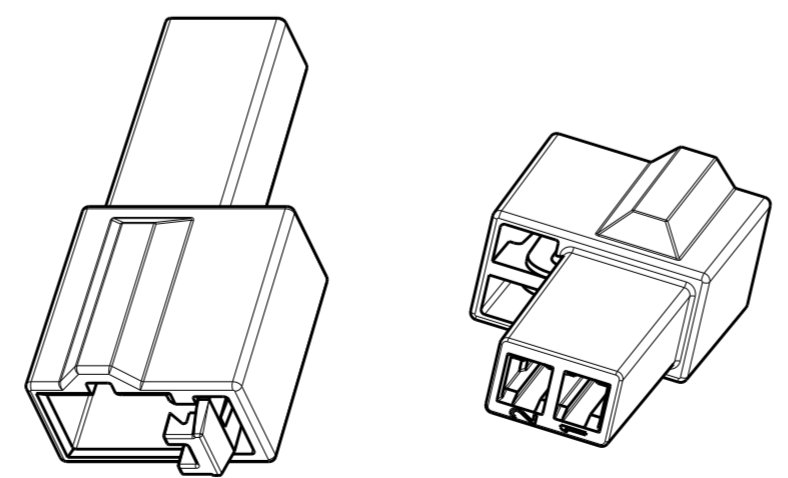

THIS DRAWING IS A CONTROLLED DOCUMENT.		DWN	M. R. BRIZ	21MAY1997	PRETO / BLACK FINISH		PA 6.6 MATERIAL	493224-1 PART NUMBER	
DIMENSIONS: mm		CHK	J. R. GOLDSCHMIDT	26 JUN 1997	STE		TE Connectivity		
TOLERANCES UNLESS OTHERWISE SPECIFIED:		APVD	A. VICENZA	20 AUG 1997	HOUSING, 2 POSN., MICRO TIMER TAB.		HOUSING, 2 POSN., MICRO TIMER TAB.		
0 PLC ±	1 PLC ±0,3	PRODUCT SPEC							
2 PLC ±0,2	3 PLC ±	APPLICATION SPEC							
4 PLC ±	ANGLES ±1°	WEIGHT							
FINISH		MATERIAL		SIZE		CAGE CODE		DRAWING NO	
SEE TABLE		SEE TABLE		A2		00779		C-493224	
		CUSTOMER DRAWING		SCALE		SHEET		REV	
				3:1		1 OF 1		D4	