

### FEATURES

**Evaluation kit for the ADM1184  $\pm 0.8\%$  accurate quad voltage monitor**

**LEDs provide a clear visual indication of device operation**

**Dedicated power and enable/disable switches**

**On-board test points allow examination of ADM1184 operation**

### GENERAL DESCRIPTION

The EVAL-ADM1184 evaluation kit demonstrates the operation of the ADM1184 as a quad voltage monitor in a multiple supply system.

The ADM1184 monitors four separate voltage rails. Each rail is adjustable using the on-board rotary switches or dedicated switches, allowing the user to investigate the result of altering each of the monitored input voltages and to simulate fault conditions.

LEDs provide a visual indication of the status of the main supply voltage, of the four monitored voltage rails, of the four outputs (OUT1 to OUT3), and of the system power-good signal (PWRGD).

### EVALUATION KIT CONTENTS

**ADM1184 main evaluation board**

**2 ADM1184 samples**

### DIGITAL PHOTO OF ADM1184 EVALUATION BOARD



Figure 1.

### Rev. 0

Evaluation boards are only intended for device evaluation and not for production purposes. Evaluation boards are supplied "as is" and without warranties of any kind, express, implied, or statutory including, but not limited to, any implied warranty of merchantability or fitness for a particular purpose. No license is granted by implication or otherwise under any patents or other intellectual property by application or use of evaluation boards. Information furnished by Analog Devices is believed to be accurate and reliable. However, no responsibility is assumed by Analog Devices for its use, nor for any infringements of patents or other rights of third parties that may result from its use. Analog Devices reserves the right to change devices or specifications at any time without notice. Trademarks and registered trademarks are the property of their respective owners. Evaluation boards are not authorized to be used in life support devices or systems.

## TABLE OF CONTENTS

|   |   |                                      |   |
|---|---|--------------------------------------|---|
| Features .....  | 1 | Powering the Evaluation Board .....  | 5 |
| General Description .....                                   | 1 | Theory of Operation .....            | 5 |
| Evaluation Kit Contents.....                                | 1 | Simulating a Power-Up Sequence ..... | 5 |
| Digital Photo Of ADM1184 Evaluation Board.....              | 1 | Observing Fault Conditions .....     | 5 |
| Revision History .....                                      | 2 | Evaluation Board Schematics.....     | 6 |
| Evaluation Board Hardware .....                             | 3 | Ordering Informations.....           | 8 |
| Connector, Switch, Jumper, LED, and Test Point Functions .. | 3 | Bill of Materials.....               | 8 |
| Evaluation Board Operation .....                            | 5 | Ordering Guide .....                 | 8 |
| ADM1184 Samples.....  | 5 | ESD Caution.....                     | 8 |

## REVISION HISTORY

10/08—Revision 0: Initial Version

## EVALUATION BOARD HARDWARE

### CONNECTOR, SWITCH, JUMPER, LED, AND TEST POINT FUNCTIONS

Table 1. Connector Functions

| Pin | Name            | Function   |
|-----|-----------------|--|
| J1  | Power connector | J1-1: Connects the positive terminal of the bench power supply to the evaluation board<br>J1-2: Connects the ground terminal of the bench power supply to the evaluation board |
| J3  | Terminal block  | J3-1: Connects a 9 V power supply to the evaluation board<br>J3-2: Connects a 9 V power supply to ground   |

Table 2. Switch Functions

| Switch | Description   | Position                    | Function   |
|--------|---|-----------------------------|--|
| S0     | Switch for powering board on/off  | 9 V<br>V <sub>CC</sub>      | Set to this position when powering the board via J3<br>Set to this position when powering the board via J1 |
| S1     | Switch for turning on/off the 3.3 V rail which is monitored by the VIN1 pin | On position<br>Off position | Enables Regulator U1<br>Disables Regulator U1  |
| S2     | Switch for turning on/off the 2.5 V rail which is monitored by the VIN2 pin | On position<br>Off position | Enables Regulator U2<br>Disables Regulator U2  |
| S3     | Switch for turning on/off the 1.8 V rail which is monitored by the VIN3 pin | On position<br>Off position | Enables Regulator U3<br>Disables Regulator U3  |
| S4     | Switch for turning on/off the 1.5 V rail which is monitored by the VIN4 pin | On position<br>Off position | Enables Regulator U4<br>Disables Regulator U4  |
| VR1    | Rotary switch   | N/A                         | Reduces the 3.3 V supply level when the switch is turned clockwise   |
| VR2    | Rotary switch   | N/A                         | Reduces the 2.5 V supply level when the switch is turned clockwise   |
| VR3    | Rotary switch   | N/A                         | Reduces the 1.8 V supply level when the switch is turned clockwise   |
| VR4    | Rotary switch   | N/A                         | Reduces the 1.5 V supply level when the switch is turned clockwise   |

Table 3. Jumper Functions

| Jumper | Description                                      | Default      |
|--------|--|--------------|
| J2     | Connects J1-1 to J3-1                            | Not inserted |
| J5     | Connects VR2 to the feedback pin of Regulator U2 | Inserted     |
| J6     | Connects VR3 to the feedback pin of Regulator U3 | Inserted     |
| J8     | Connects VR1 to the feedback pin of Regulator U1 | Inserted     |
| J12    | Connects VR4 to the feedback pin of Regulator U4 | Inserted     |

Table 4. LED Functions

| LED | Name         | Function  |
|-----|--------------|---|
| D1  | VCC          | A red LED indicates that the board is powered on              |
| D2  | 3.3 V (VIN1) | A yellow LED indicates the status of the 3.3 V supply voltage |
| D3  | 2.5 V (VIN2) | A yellow LED indicates the status of the 2.5 V supply voltage |
| D4  | 1.8 V (VIN3) | A yellow LED indicates the status of the 1.8 V supply voltage |
| D5  | 1.5 V (VIN4) | A yellow LED indicates the status of the 1.5 V supply voltage |
| D6  | OUT1         | A green LED indicates when the OUT1 output is asserted        |
| D7  | OUT2         | A green LED indicates when the OUT2 output is asserted        |
| D8  | OUT3         | A green LED indicates when the OUT3 output is asserted        |
| D9  | PWRGD        | A green LED indicates when the PWRGD output is asserted       |

# EVAL-ADM1184

**Table 5. Test Point Functions**

| <b>Test Point</b> | <b>Function</b>                                  |
|-------------------|--|
| 1_5V              | Connected to the 1.5 V rail                      |
| 1_8V              | Connected to the 1.8 V rail                      |
| 2_5V              | Connected to the 2.5 V rail                      |
| 3_3V              | Connected to the 3.3 V rail                      |
| GND               | Connected to ground                              |
| GND1              | Connected to ground                              |
| GND2              | Connected to ground                              |
| GND3              | Connected to ground                              |
| OUT1              | Connected to the OUT1 pin of the ADM1184 device  |
| OUT2              | Connected to the OUT2 pin of the ADM1184 device  |
| OUT3              | Connected to the OUT3 pin of the ADM1184 device  |
| PWRGD             | Connected to the PWRGD pin of the ADM1184 device |
| VIN1              | Connected to VIN1 pin of the ADM1184 device      |
| VIN2              | Connected to VIN2 pin of the ADM1184 device      |
| VIN3              | Connected to VIN3 pin of the ADM1184 device      |
| VIN4              | Connected to VIN4 pin of the ADM1184 device      |

# EVALUATION BOARD OPERATION

## ADM1184 SAMPLES

Two loose ADM1184 samples are included in the evaluation kit. If the board does not have a device soldered in place, place a single sample in the socket labeled U6 before powering on the evaluation board.

## POWERING THE EVALUATION BOARD

There are two methods of powering the EVAL-ADM1184: connect a 9 V power supply through J3 or connect a bench supply through J1. When using a 9 V power supply, be sure to place S2 to the 9 V position; alternatively, when using a bench supply, adjust S2 to the V<sub>CC</sub> position.

## THEORY OF OPERATION

Four voltage rails are monitored by the ADM1184. Resistor networks external to the VIN1, VIN2, VIN3, and VIN4 pins set the trip points for the monitored rails, 3.3 V, 2.5 V, 1.8 V, and 1.5 V.

Output OUT1 to Output OUT3 are solely dependent on their associated input (that is, VIN1, VIN2, or VIN3). Before the voltage on a VIN<sub>x</sub> input reaches 0.6 V, the corresponding output is switched to ground. When VIN<sub>x</sub> detects 0.6 V, OUT<sub>x</sub> is asserted after a 30 μs delay.

When all four monitored supplies exceed their programmed thresholds a system power good signal (PWRGD) is asserted. There is an internal 190 ms delay associated with the assertion

of the PWRGD output. After PWRGD is asserted, if any of the four monitored supplies drops below its programmed threshold, the corresponding OUT<sub>x</sub> output and the PWRGD output are deasserted. If the supply monitored by VIN4 drops below its programmed threshold, the PWRGD output is only deasserted.

## SIMULATING A POWER-UP SEQUENCE

Begin with all four rotary positions turned fully counter-clockwise. Power on each of the four voltage rails by switching the associated dedicated switch, S1 to S4, to the on position. The rails may be powered on in any order. Yellow LEDs (D2, D3, D4, and D5) provide a visual indication of the status of each of the four voltage rails, while green LEDs (D6, D7, D8, and D9) indicate when the OUT1 to OUT3 outputs and the system PWRGD signal are asserted. The 190 ms delay associated with the assertion of the power-good signal is easily observed.

## OBSERVING FAULT CONDITIONS

Fault conditions may be investigated by using the four rotary switches, VR1 to VR4. By turning a rotary switch clockwise, the associated input voltage is reduced.

Each rotary switch (VR1 to VR4) controls the voltage at each of the VIN1 to VIN4 inputs. As the rotary switch is turned clockwise, the voltage monitored by VIN<sub>x</sub> is reduced. When the voltage at the VIN<sub>x</sub> input pin drops below 0.6 V, OUT<sub>x</sub> is switched to ground. The PWRGD output is also deasserted immediately.

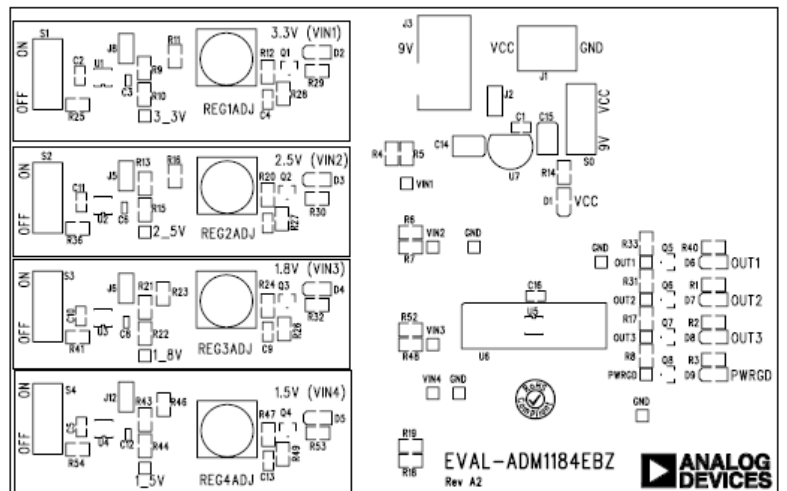

Figure 2. ADM1184 Evaluation Board Silkscreen

# EVAL-ADM1184

## EVALUATION BOARD SCHEMATICS

07766-002

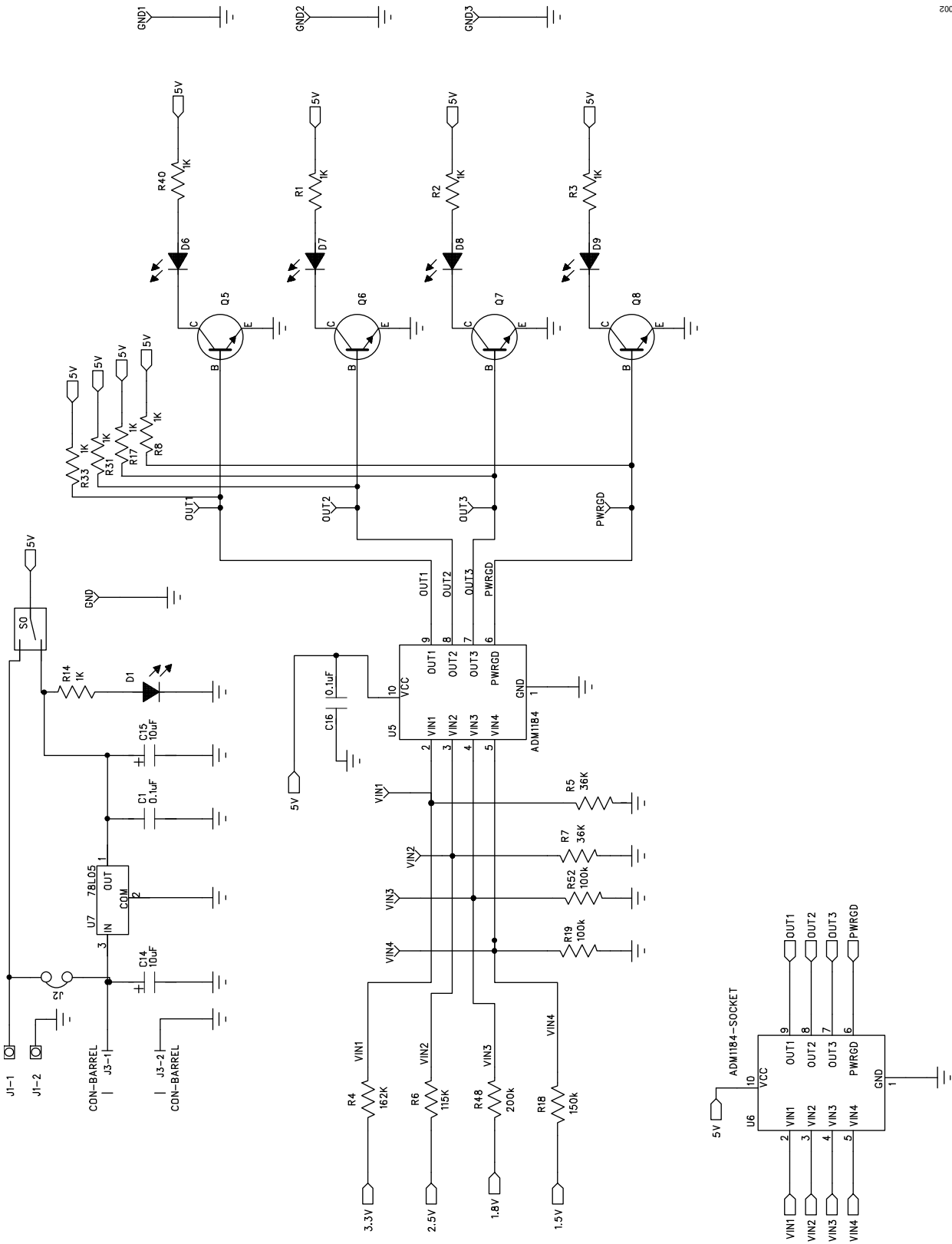

Figure 3. ADM1184 Evaluation Board Schematic, Page 1

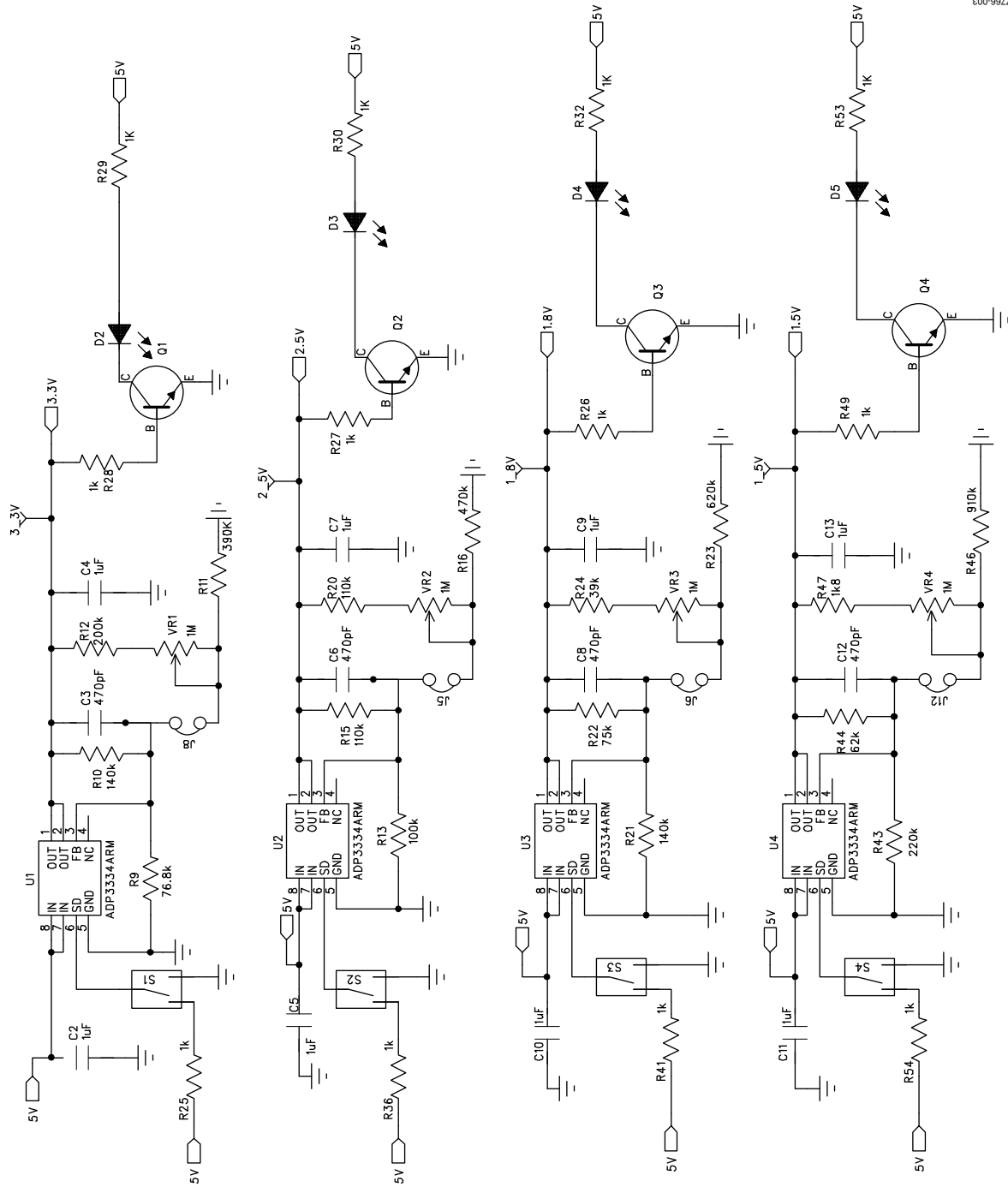

Figure 4. ADM1184 Evaluation Board Schematic, Page 2

# EVAL-ADM1184

## ORDERING INFORMATION

### BILL OF MATERIALS

Table 6.

| Qty | Reference Designator  | Description  | Part No. <sup>1</sup>        |
|-----|---|--|------------------------------|
| 2   | C1, C16   | 0.1 µF, 0603 capacitor                             | FEC 432210                   |
| 8   | C2, C4, C5, C7, C9, C10, C11, C13   | 1 µF, 0603 capacitor                               | FEC 3188840                  |
| 4   | C3, C6, C8, C12   | 470 pF, 0402 capacitor                             | FEC 3019366                  |
| 2   | C14, C15  | 10 µF, 0603 capacitor                              | FEC 9753893                  |
| 1   | D1  | 0805 red LED                                       | FEC 1021302                  |
| 4   | D2, D3, D4, D5  | 0805 yellow LED                                    | FEC 1318247                  |
| 4   | D6, D7, D8, D9  | 0805 green LED                                     | FEC 1318243                  |
| 1   | J1  | 2-pin terminal block, connector/power              | FEC 151789                   |
| 5   | J2, J5, J6, J8, J12   | Jumper, SIP-2P                                     | FEC 1022247                  |
| 1   | J3  | DC barrel power connector, connector\barrel        | FEC 224959                   |
| 8   | Q1, Q2, Q3, Q4, Q5, Q6, Q7, Q8  | NPD SMD transistor, SOT-23                         | FEC 1081239                  |
| 21  | R1, R2, R3, R8, R14, R17, R25, R26, R27, R28, R29, R30, R31, R32, R33, R36, R40, R41, R49, R53, R54 | 1 kΩ, 0805 resistor                                | FEC 9332383                  |
| 1   | R4  | 162 kΩ, 0805 resistor                              | FEC 1160272                  |
| 2   | R5, R7  | 36 kΩ, 0805 resistor                               | FEC 1108905                  |
| 1   | R6  | 115 kΩ, 0805 resistor                              | FEC 1140356                  |
| 1   | R9  | 76.8 kΩ, 0805 resistor                             | FEC 1141007                  |
| 2   | R10, R21  | 140 kΩ, 0805 resistor                              | FEC 1160268                  |
| 1   | R11   | 390 kΩ, 0805 resistor                              | FEC 9333185                  |
| 2   | R12, R48  | 200 kΩ, 0805 resistor                              | FEC 9332782                  |
| 3   | R13, R19, R52   | 100 kΩ, 0805 resistor                              | FEC 9332405                  |
| 2   | R15, R20  | 110 kΩ, 0805 resistor                              | FEC 9332464                  |
| 1   | R16   | 470 kΩ, 0805 resistor                              | FEC 9333282                  |
| 1   | R18   | 150 kΩ, 0805 resistor                              | FEC 9332626                  |
| 1   | R22   | 75 kΩ, 0603 resistor                               | FEC 9331522                  |
| 1   | R23   | 620 kΩ, 0805 resistor                              | FEC 9333444                  |
| 1   | R24   | 39 kΩ, 0805 resistor                               | FEC 9333177                  |
| 1   | R43   | 220 kΩ, 0805 resistor                              | FEC 9332839                  |
| 1   | R44   | 62 kΩ, 0805 resistor                               | FEC 9333436                  |
| 1   | R46   | 910 kΩ, 0805 resistor                              | FEC 9333657                  |
| 1   | R47   | 1.8 kΩ, 0805 resistor                              | FEC 9332715                  |
| 5   | S0, S1, S2, S3, S4  | SPDT slide switch, SW-SPDT-SLIDE                   | FEC 1123875                  |
| 4   | VR1, VR2, VR3, VR4  | Trimmer potentiometer, 1 M, VRES_ROTARY            | FEC 9608290                  |
| 16  | 1_5V, 1_8V, 2_5V, 3_3V, GND, GND1, GND2, GND3, OUT1, OUT2, OUT3, PWRGD, VIN1, VIN2, VIN3, VIN4      | Testpoint  | FEC 8731144                  |
| 4   | U1, U2, U3, U4  | ADP3334ARM adjustable LDO regulator, MS08          | Free issue by Analog Devices |
| 1   | U5  | ADM1184 quad voltage monitor MS010                 | Free issue by Analog Devices |
| 1   | U6  | 10-pin MSOP socket, MS010-SKT                      | Abrel Products 6560102211    |
| 1   | U7  | 3-terminal 0.1 A positive voltage regulator, TO-92 | FEC 9489444                  |

<sup>1</sup> FEC = Farnell Electronics.

### ORDERING GUIDE

| Model                        | Description            |
|------------------------------|------------------------|
| EVAL-ADM1184EBZ <sup>1</sup> | ADM1184 Evaluation Kit |

<sup>1</sup> Z = RoHS Compliant Part.

### ESD CAUTION



**ESD (electrostatic discharge) sensitive device.** Charged devices and circuit boards can discharge without detection. Although this product features patented or proprietary protection circuitry, damage may occur on devices subjected to high energy ESD. Therefore, proper ESD precautions should be taken to avoid performance degradation or loss of functionality.