

Frequency Foldback Current Mode PWM Controller

FEATURES

- Frequency Foldback Reduces Operating Frequency Under Fault Conditions
- Accurate Programmable Volt-Second Clamp
- Programmable Maximum Duty Cycle Clamp
- Oscillator Synchronization
- Overcurrent Protection
- Shutdown With Full Soft Start
- Wide Gain Bandwidth Amplifier (GBW > 2.5 MHz)
- Current Mode Operation
- Precision 5-V Reference

DESCRIPTION

The UCC3884 is a high performance current mode PWM controller intended for single ended switch mode power supplies. The chip implements a frequency foldback scheme that decreases the oscillator frequency as the output voltage falls below a programmed value. This technique decreases the average output current sourced into a low impedance load which can occur during an output short circuit or overload condition. Excessive short circuit current is more prevalent in high frequency converters where the propagation delay and switch turn-off time forces a minimum attainable duty cycle. An accurate volt-second clamp limits the duty cycle during line or load transient conditions which could otherwise saturate the transformer. The volt-second clamp may also be used with an external overvoltage protection circuit to handle fault conditions such as current sense disconnect or current transformer saturation.

The frequency foldback, volt-second clamp, cycle-by-cycle current limit, and overcurrent shutdown provide a rich set of protection features for use in peak current-mode pulse width modulators.

OSCILLATOR SYNCHRONIZATION

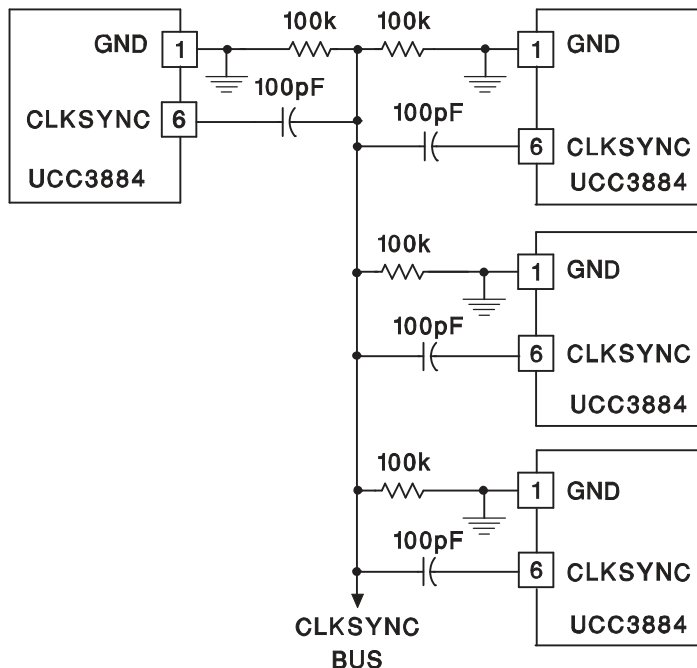

Please be aware that an important notice concerning availability, standard warranty, and use in critical applications of Texas Instruments semiconductor products and disclaimers thereto appears at the end of this data sheet.

ABSOLUTE MAXIMUM RATINGS⁽¹⁾

	VALUE	UNIT
Supply voltage	15	V
Output sink current	1	A
Output source current	0.5	
All other pins	6	V
Storage temperature	–65 TO 150	°C
Junction temperature	–40 TO 150	
Lead temperature (soldering, 10 sec)	300	

(1) Currents are positive into, negative out of the specified terminal.

ORDERING INFORMATION

T _J	PACKAGED DEVICES ⁽¹⁾	
	SOP (D)	PDIP(N)
–40°C to 85°C	UCC2884D (16)	UCC2884N (16)
0°C to 70°C	UCC3884D (16)	UCC3884N (16)

(1) Both the D and N packages are available taped and reeled (indicated by the TR suffix on the device type e.g., UCC2884DTR)

CONNECTION DIAGRAMS

N or D Package (Top View)

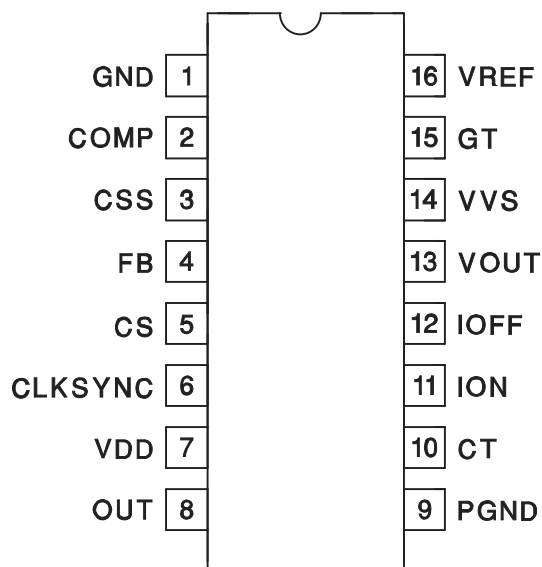

Block Diagram

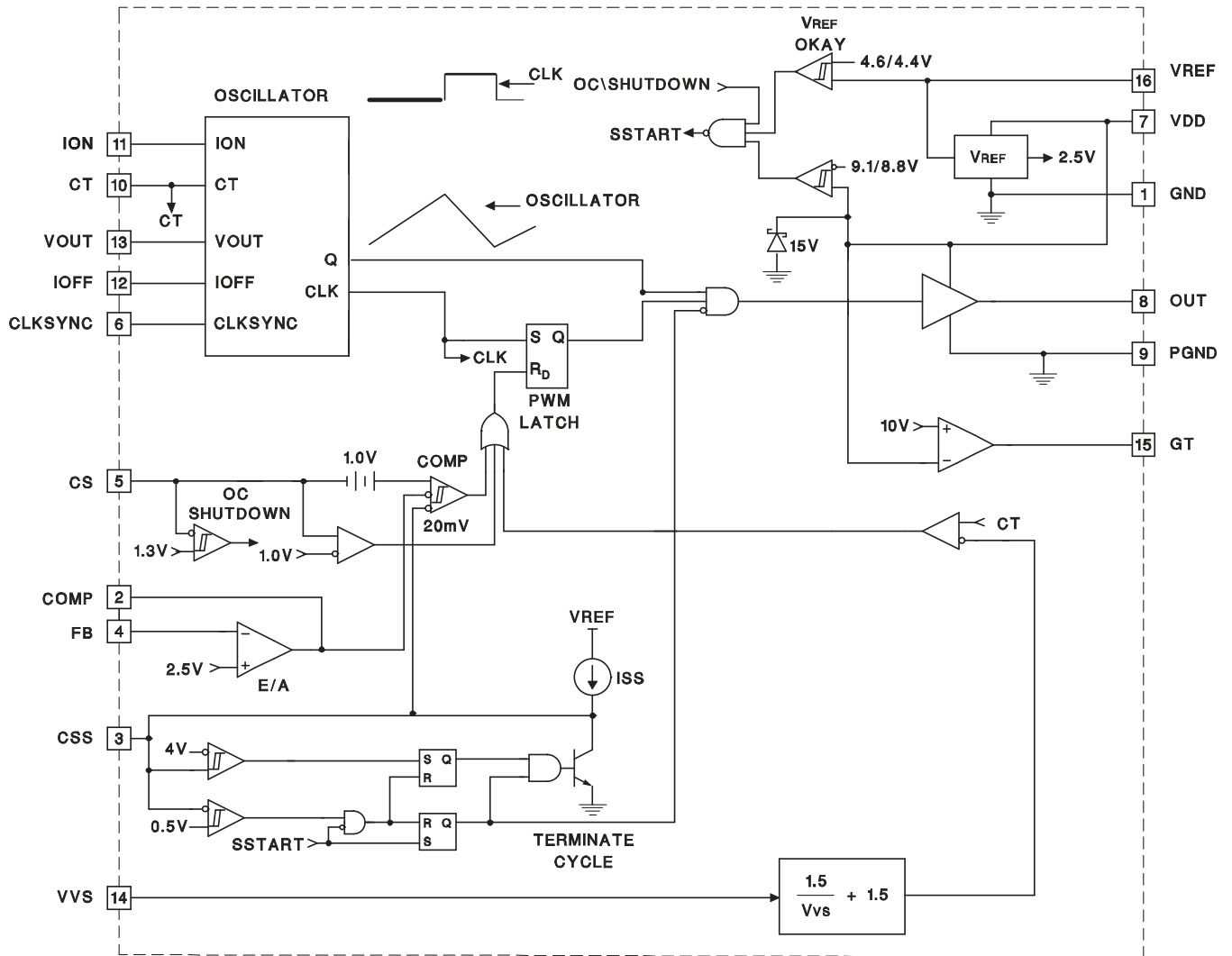

ELECTRICAL CHARACTERISTICS

Unless otherwise specified, these specifications apply for $T_A = -40^\circ\text{C}$ to 85°C for the UCC2884, and 0°C to 70°C for the UCC3884, $C_T = 220\text{ pF}$, $R_{ON} = 53\text{ k}\Omega$, $R_{OFF} = 38\text{ k}\Omega$, $V_{OUT} = V_{REF}$, $V_{VS} = 0\text{ V}$, $C_{SS} = 2.5\text{ nF}$, $V_{DD} = 11\text{ V}$, Output no load, $T_A = T_J$.

PARAMETER	TEST CONDITIONS	MIN	TYP	MAX	UNIT
5-V Reference					
V_{REF}	$I_{REF} = 0\text{ mA}$	4.86	5	5.14	V
Line regulation	$V_{DD} = 10\text{ V}$ to 12 V		1	10	mV
Load regulation	$0 < I_{REF} < 5\text{ mA}$		1	20	
Short circuit	$V_{REF} = 0\text{ V}$		15	45	mA
Oscillator					
Accuracy	$V_{OUT} = V_{REF}$	360	400	440	kHz
Foldback frequency	$V_{OUT} = 0.75\text{ V}$	200	230	260	
CLKSYNC output high		4.8	5	5.2	V
CLKSYNC output low			0.0	0.4	
CLKSYNC sink current	$CLKSYNC = 1\text{ V}$	1.2	2.2		mA
CLKSYNC source current	$CLKSYNC = 3\text{ V}$		-0.2	0.1	
CLKSYNC input threshold	$CLKSYNC$ from 5 V to 0 V (edge detect)	2.5	3.0	3.5	V
Error Amplifier					
I_B	Total bias current; regulating level	-1		1	μA
FB voltage	$FB = COMP$	2.43	2.5	2.57	V
A_{VO}		50	90		dB
GBW	$F = 100\text{ kHz}$ ⁽¹⁾	2.5	5		MHz
Output source current	$FB = 2.3\text{ V}$, $COMP = 2.5\text{ V}$	-0.6	-1.2		mA
Output sink current	$FB = 2.7\text{ V}$, $V_{COMP} = 1\text{ V}$	0.250	1.5		
V_{OL}	$I_O = 100\text{ }\mu\text{A}$		0.3	0.9	V
V_{OL}	$I_O = -100\text{ }\mu\text{A}$	2.7	3.1	3.5	
PWM					
Minimum duty cycle	$FB = 3\text{ V}$, $CS = 0\text{ V}$			0%	
Maximum duty cycle	$FB = 0\text{ V}$, $CS = 0\text{ V}$	75%	78%	81%	
Current Sense					
Input bias current (CS)				3.0	μA
CS shutdown threshold		1.235	1.3	1.365	V
CS shutdown hysteresis			20		mV
CS over current threshold		0.95	1	1.05	V
Current/FAULT					
Soft start charge current		-10	-20	-30	μA
Soft start discharge current		10	20	30	
V_{OL}			0	50	mV
Soft start complete threshold		3.6	4	4.4	V
Soft start restart threshold		0.4	0.5	0.6	

(1) Specified by design. Not 100% tested in production.

ELECTRICAL CHARACTERISTICS (continued)

Unless otherwise specified, these specifications apply for $T_A = -40^{\circ}\text{C}$ to 85°C for the UCC2884, and 0°C to 70°C for the UCC3884, $C_T = 220\text{ pF}$, $R_{ON} = 53\text{ k}\Omega$, $R_{OFF} = 38\text{ k}\Omega$, $V_{OUT} = V_{REF}$, $V_{VS} = 0\text{ V}$, $C_{SS} = 2.5\text{ nF}$, $V_{DD} = 11\text{ V}$, Output no load, $T_A = T_J$.

PARAMETER	TEST CONDITIONS	MIN	TYP	MAX	UNIT
Volt Second Clamp					
Duty cycle	$V_{VS} = 1.4\text{ V}$, $T_A = 40^{\circ}\text{C}$ to 85°C	50%	60%	70%	
	$V_{VS} = 1.4\text{ V}$, $T_A = 0^{\circ}\text{C}$ to 70°C	52%	57%	67%	
	$V_{VS} = 3.6\text{ V}$, $T_A = -40^{\circ}\text{C}$ to 85°C	20.5%	22.0%	25.5%	
	$V_{VS} = 3.6\text{ V}$, $T_A = 0^{\circ}\text{C}$ to 70°C	20.5%	22.0%	23.5%	
I_B	$V_{VS} = 3.7\text{ V}$	-1		1	μA
Output Stage					
Output low saturation	$I_{OUT} = 100\text{ mA}$		0.5	0.9	V
Output low saturation	$I_{OUT} = -50\text{ mA}$		0.5	0.9	
	$I_{OUT} = 200\text{ mA}$ ⁽²⁾			1.9	
UVLO output low saturation	$I_{OUT} = 20\text{ mA}$, $V_{DD} = 0\text{ V}$		0.7	1.2	ns
Rise time	$C_L = 1\text{ nF}$		50	70	
Fall time	$C_L = 1\text{ nF}$		30	50	
Undervoltage Lockout					
Turn-on threshold voltage		8.4	8.9	9.4	V
Hysteresis		200	600	1000	mV
Startup Regulator					
Regulated VDD voltage		9.5	10	10.5	V
VDD override threshold				10.7	
Overall					
V_{DD} range				14.5	V
I_{DD} (run)	$f = 400\text{ kHz}$	2	5	10	mA
I_{DD} startup current	$V_{DD} = 5.4\text{ V}$	100		250	μA
VDD clamp	$I_{DD} = 10\text{ mA}$	12	13.5	15	V

(2) Specified by design. Not 100% tested in production.

PIN DESCRIPTIONS

CLKSYNC: An edge triggered active low TTL signal to this pin synchronizes the oscillator to an external clock. When VOUT decreases below 3.0 V, the frequency foldback circuit is activated and the controller becomes unsynchronized. When VOUT exceeds 3.0 V, the controller resynchronizes to the external clock.

COMP: The output of the voltage error amplifier used for compensation. The output is clamped to 3.0 V minimum.

CS: Current sense input. This pin accepts a voltage proportional to converter inductor current. The voltage CS is compared to the output of the compensated error amplifier to control the on-time of the switch. Voltage mode control can be realized by driving this pin with fixed sawtooth ramp. Voltage feedforward is achieved by making the peak of this ramp proportional to the input voltage.

CSS: A capacitor, CSS, to ground programs the soft-start time for the power-up sequence. This function is also used when an overcurrent fault occurs. As CSS is charged, the PWM comparator uses the lowest of either the voltage at CSS or the error amplifier output voltage to determine the duty cycle. The duty cycle, therefore, slowly increases during the soft-start cycle. The faults that cause CSS to discharge and shutdown the controller are the logical OR of VREF below 4.4 V or VDD below 8.8 V. If a fault is still present when CSS is discharged below 0.5 V, the supply remains off until the fault is cleared. The soft-start time is determined by:

$$t_{SS} = 3.5 \times \frac{C_{SS}}{I_{SS}}$$

where I_{SS} is 20 μ A. A current limit terminates the present cycle. It does not generate a soft start cycle.

CT: A capacitor, C_T to ground, is charged and discharged creating the oscillator waveform. This waveform varies between 1.5 V and 3.5 V. The operating frequency is determined by:

$$f = \frac{4.4}{C_T \times \left(\frac{R_{ON}}{1.5} + \frac{R_{OFF}}{3.5} \right)}$$

The ratio of the time duration of the positive sloped portion of the CT voltage waveform to the period gives the maximum duty cycle.

FB: The inverting input of the voltage amplifier used to sense the output voltage. The non-inverting input of the error amplifier is internally connected to 2.5 V.

GND: The ground pin internally used for all the amplifiers and as the return for all resistor and capacitor connections to the UCC3884.

GT: Used to drive an external depletion-mode MOSFET for the housekeeping power supply. The MOSFET is turned off when the bootstrap winding voltage exceeds 10 V. There is 300 mV of hysteresis around the 10-V, turn-off voltage to prevent oscillation. See Typical Application.

IOFF: A resistor, R_{OFF} , to ground, programs the discharge current of the timing capacitor C_T . This is a variable discharge current which determines the negative slope of the oscillator voltage waveform at CT. The discharge time is dependent on the voltage at the VOUT pin. The discharge current is given by:

$$I_{OFF} = \frac{VOUT}{R_{OFF}}$$

The VOUT pin is internally clamped to 3.5 V maximum.

ION: A resistor, R_{ON} , to ground programs the charge current of the timing capacitor, C_T , which generates the positive slope of the oscillator waveform. The charge time is constant and corresponds to the maximum output on-time at OUT. The charge current equation is:

$$I_{ON} = \frac{1.5V}{R_{ON}}$$

When required the linear positive slope of the C_T voltage could be buffered and used to provide slope compensation into the CS pin.

OUT: The output of the controller. The peak source current is 0.5 A and the peak sink current is 1.0 A. The faults listed under the CSS description turn off this output.

PGND: The power ground pin is used as the return for the output transistor drive stage.

VDD: The input voltage of the chip. A low ESR and ESL ceramic capacitor from this pin to GND should be used to bypass internal switching transients.

VOUT: This pin accomplishes frequency foldback by controlling the discharge current for the oscillator C_T capacitor. A dc voltage proportional to the output voltage is connected to this pin. To startup with zero output voltage the user should tie a resistor between VREF and VOUT. The value depends on the lowest desired operating frequency. When VOUT decreases below 3.5 V the frequency decreases by reducing the discharge current I_{OFF} . When VOUT increases, the frequency increases by increasing the discharge current. The maximum operating frequency occurs when $VOUT = 3.5$ V. The C_T charge time is constant to assure a maximum output duty cycle. This pin must be above 3.0 V to allow synchronization to occur.

VREF: This pin is the output of the 5-V regulated reference. Bypass this pin with a low ESR and ESL ceramic capacitor (e.g., 0.47 μ F).

VVS: Provides a programmable duty cycle clamp which is dependent upon the input voltage. A resistor divider network reduces the input voltage supplied to VVS. The device determines the reciprocal of the voltage at VVS and scales the result. The voltage is then compared to the oscillator waveform to clamp the duty cycle. The purpose of this clamp is to reduce the likelihood of saturating the isolation transformer during unusual line or load conditions.

APPLICATION INFORMATION

Theory of Operation

The UCC3884 current-mode PWM controller contains a programmable oscillator which includes the ability to synchronize multiple PWMs. The positive and negative sloped portions of the oscillator waveform (measured at CT), have time intervals that are set by external resistors at ION and IOFF. The operating frequency is inversely proportional to the timing capacitor. The negative sloped portion of the oscillator waveform is extended in time as the measured output voltage decreases providing protection during output faults. The power supply output voltage and the voltage from VREF are fed back to VOUT. When the output voltage decreases, the voltage at VOUT also decreases. As VOUT decreases below 3.5 V, the operating frequency decreases. This reduction in frequency allows the duty cycle to decrease below what the CS to OUT delay would otherwise permit. This is referred to as frequency foldback. An output short circuit or overload causes the converter to enter the frequency foldback mode. Synchronization to other controllers can only occur during normal operation, that is, when VOUT is greater than 3.0 V.

GT is provided to turn off an external depletion-mode MOSFET after startup when the bootstrap winding exceeds 10 V. This depletion-mode MOSFET is used in the housekeeping section of the converter to simplify startup biasing circuitry. The amplifier that drives this MOSFET has 300 mV of hysteresis to avoid oscillation during power up.

An accurate programmable volt-second technique clamps the duty cycle. The duty cycle limit is inversely proportional to input voltage and a resistor divider network is used to program the proportionality constant. At a given input voltage and constant load, under closed loop control, the operating duty cycle is a fixed value. The volt-second clamp duty cycle may then be set somewhat higher than this operating duty cycle. For other input voltages, the volt-second clamp still exceeds the steady state operating duty cycle. This allows normal closed loop operation of the converter. It is during a load transient (a fault such as a momentary short circuit) as the error amplifier increases the duty cycle, that when the volt-second clamp accurately limits the maximum volt-seconds. This ensures that the transformer does not saturate during a fault which can fail the power supply. After the fault is removed the converter resumes closed loop control.

CSS is provided which allows the UCC3884 to be disabled with an external transistor. The increasing pulse width at OUT during soft start should be programmed to be less than the pulse width of the duty cycle limit that the frequency foldback circuitry creates. The frequency foldback circuit will be in effect during soft start since the output voltage fed back to VOUT is less than 3.5 V. Designing the circuit in this fashion allows a proper startup sequence.

The current sense feedback pin has an overcurrent protection feature which forces a soft start cycle only if the device is not currently in a soft-start cycle. A 1-V bias at the PWM comparator's non-inverting input and a reset dominant PWM latch permit zero duty cycle operation.

The error amplifier has a wide gain-bandwidth product and its non-inverting input is internally set to 2.5 VDC.

Synchronization Techniques

The following explains two synchronization techniques:

1. **Initially Undefined Master** If the user does not care which unit is the master, then the oscillator frequencies are designed as accurate as necessary and one unit becomes the master and synchronizes the remaining units. The user never knows exactly which unit will be the master upon power up.
2. **User-Defined Master** If the user does care which unit is the master, a unit should be identified as the master, and the frequency and maximum duty cycle clamp should be programmed accordingly. The ROFF resistor which programs the slave units oscillator discharge ramp should be between 50% and 100% of the ROFF resistor which programs the master. This ensures that if a slave unit tries to synchronize the master, the master frequency will still be faster than the slave frequency and the master synchronizes all the remaining units.

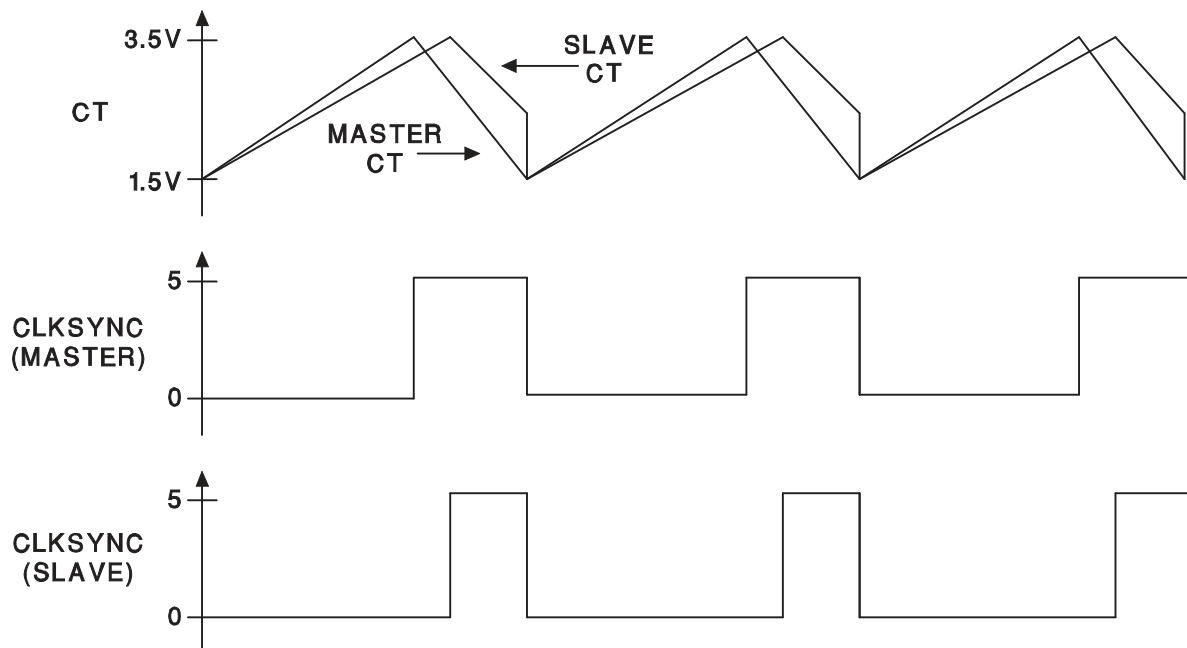

Figure 2. Oscillator Waveforms

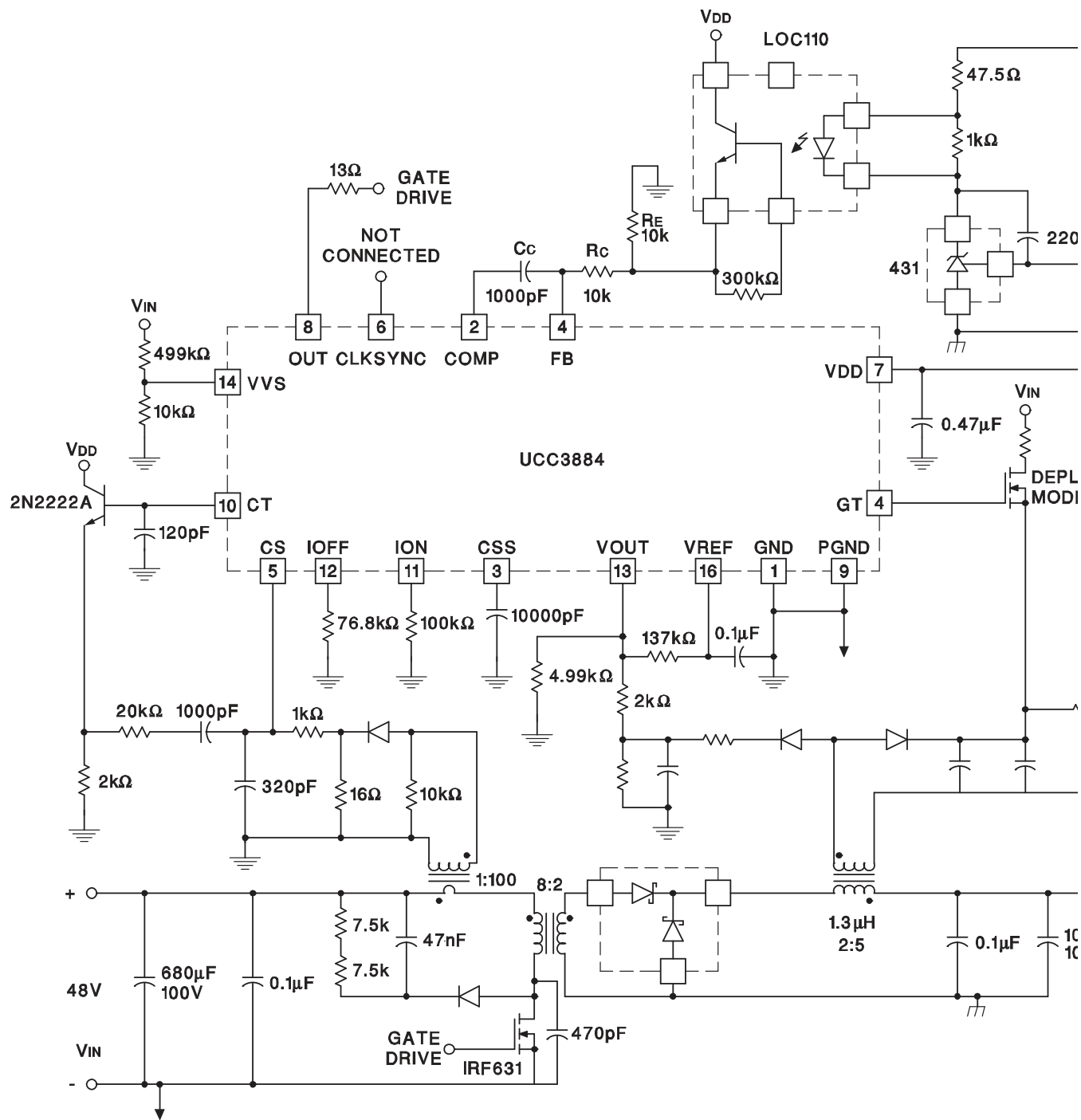

Figure 3. Typical Application

IMPORTANT NOTICE

Texas Instruments Incorporated and its subsidiaries (TI) reserve the right to make corrections, modifications, enhancements, improvements, and other changes to its products and services at any time and to discontinue any product or service without notice. Customers should obtain the latest relevant information before placing orders and should verify that such information is current and complete. All products are sold subject to TI's terms and conditions of sale supplied at the time of order acknowledgment.

TI warrants performance of its hardware products to the specifications applicable at the time of sale in accordance with TI's standard warranty. Testing and other quality control techniques are used to the extent TI deems necessary to support this warranty. Except where mandated by government requirements, testing of all parameters of each product is not necessarily performed.

TI assumes no liability for applications assistance or customer product design. Customers are responsible for their products and applications using TI components. To minimize the risks associated with customer products and applications, customers should provide adequate design and operating safeguards.

TI does not warrant or represent that any license, either express or implied, is granted under any TI patent right, copyright, mask work right, or other TI intellectual property right relating to any combination, machine, or process in which TI products or services are used. Information published by TI regarding third-party products or services does not constitute a license from TI to use such products or services or a warranty or endorsement thereof. Use of such information may require a license from a third party under the patents or other intellectual property of the third party, or a license from TI under the patents or other intellectual property of TI.

Reproduction of TI information in TI data books or data sheets is permissible only if reproduction is without alteration and is accompanied by all associated warranties, conditions, limitations, and notices. Reproduction of this information with alteration is an unfair and deceptive business practice. TI is not responsible or liable for such altered documentation. Information of third parties may be subject to additional restrictions.

Resale of TI products or services with statements different from or beyond the parameters stated by TI for that product or service voids all express and any implied warranties for the associated TI product or service and is an unfair and deceptive business practice. TI is not responsible or liable for any such statements.

TI products are not authorized for use in safety-critical applications (such as life support) where a failure of the TI product would reasonably be expected to cause severe personal injury or death, unless officers of the parties have executed an agreement specifically governing such use. Buyers represent that they have all necessary expertise in the safety and regulatory ramifications of their applications, and acknowledge and agree that they are solely responsible for all legal, regulatory and safety-related requirements concerning their products and any use of TI products in such safety-critical applications, notwithstanding any applications-related information or support that may be provided by TI. Further, Buyers must fully indemnify TI and its representatives against any damages arising out of the use of TI products in such safety-critical applications.

TI products are neither designed nor intended for use in military/aerospace applications or environments unless the TI products are specifically designated by TI as military-grade or "enhanced plastic." Only products designated by TI as military-grade meet military specifications. Buyers acknowledge and agree that any such use of TI products which TI has not designated as military-grade is solely at the Buyer's risk, and that they are solely responsible for compliance with all legal and regulatory requirements in connection with such use.

TI products are neither designed nor intended for use in automotive applications or environments unless the specific TI products are designated by TI as compliant with ISO/TS 16949 requirements. Buyers acknowledge and agree that, if they use any non-designated products in automotive applications, TI will not be responsible for any failure to meet such requirements.

Following are URLs where you can obtain information on other Texas Instruments products and application solutions:

Products

Amplifiers	amplifier.ti.com
Data Converters	dataconverter.ti.com
DSP	dsp.ti.com
Clocks and Timers	www.ti.com/clocks
Interface	interface.ti.com
Logic	logic.ti.com
Power Mgmt	power.ti.com
Microcontrollers	microcontroller.ti.com
RFID	www.ti-rfid.com
RF/IF and ZigBee® Solutions	www.ti.com/lprf

Applications

Audio	www.ti.com/audio
Automotive	www.ti.com/automotive
Broadband	www.ti.com/broadband
Digital Control	www.ti.com/digitalcontrol
Medical	www.ti.com/medical
Military	www.ti.com/military
Optical Networking	www.ti.com/opticalnetwork
Security	www.ti.com/security
Telephony	www.ti.com/telephony
Video & Imaging	www.ti.com/video
Wireless	www.ti.com/wireless

Mailing Address: Texas Instruments, Post Office Box 655303, Dallas, Texas 75265
Copyright © 2008, Texas Instruments Incorporated