

SECTION B-B

REEL

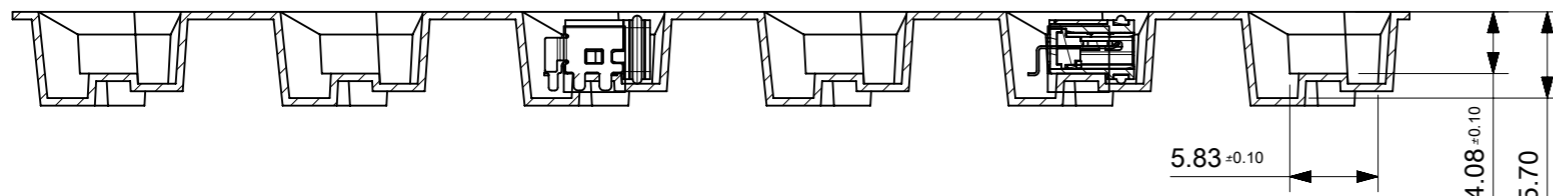

SECTION A-A

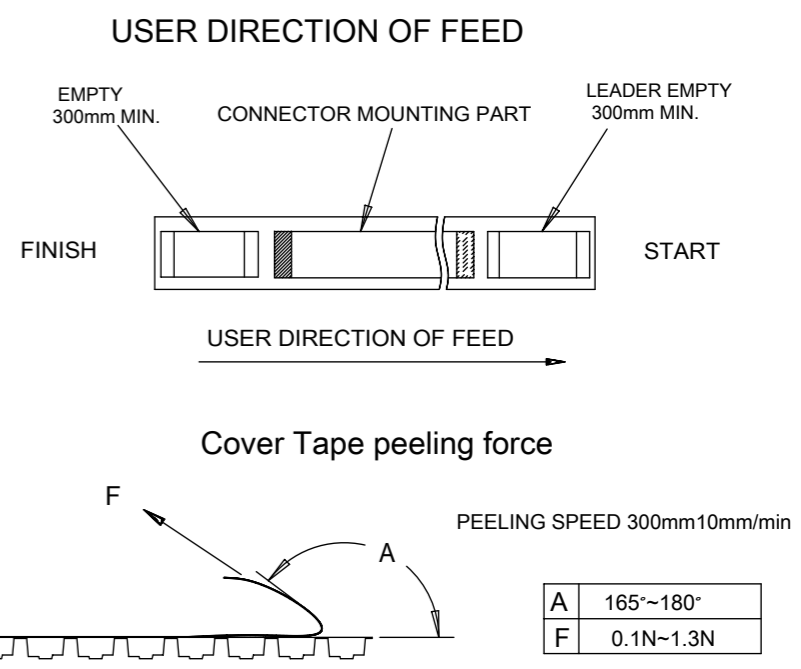

NOTES:

1. MATERIAL: 0.50±0.05mm PS/CLEAR.
2. GENERAL TOLERANCE: ±0.20mm UNLESS OTHERWISE STATED.
3. DRAFT ANGLE: 5° MAXIMUM TYP.
4. UNLESS OTHERWISE SPECIFIED RADIUS: 0.30mm MAXIMUM.
5. MAXIMUM CUMULATIVE TOLERANCE FOR 10 SOCKETS HOLE PITCH: ±0.20mm.
6. NO HIT MARKS, BRIDGES AND CRACKS ALLOWED.
7. CAMBERS DON'T EXCEED 1.0mm IN 250mm.
8. CARRIER TAPE PART NUMBER: 88596-1619.
9. COMPLIANT TO RoHS DIRECTIVE 2011/65/EU AND ELV 2000/53/EC.

THIS DRAWING CONTAINS INFORMATION THAT IS PROPRIETARY TO MOLEX ELECTRONIC TECHNOLOGIES, LLC AND SHOULD NOT BE USED WITHOUT WRITTEN PERMISSION											
QUALITY SYMBOLS	2018/02/05 2018/02/07 2018/02/07	GENERAL TOLERANCES (UNLESS SPECIFIED)		DIMENSION UNITS	SCALE	<p>PACKAGING DRAWING FOR USB, MICRO-B WATER PROOF</p> <p>PACKAGING DESIGN DRAWING</p>					
		ANGULAR TOL ± 3.0 °		mm	2:1						
▽A = 0	EC NO: 171707 DRWN: TLI97 CHK'D: RZHANG APPR: RZHANG	4 PLACES ±	TLI97	DATE	2017/06/14						
▽E = 0		3 PLACES ±	CHK'D BY	DATE							
▽F = 0		2 PLACES ± 0.2	RZHANG	2017/08/01							
▽ = 0		1 PLACE ± 0.25	DRAWING SIZE	THIRD ANGLE PROJECTION							
▽ = 0		0 PLACES ±	A3								
▽ = 0		DRAFT WHERE APPLICABLE MUST REMAIN WITHIN DIMENSIONS				SERIES	MATERIAL NUMBER	CUSTOMER			
						204926	SEE TABLE	GENERAL MARKET			
						DOCUMENT NUMBER		DOC TYPE	DOC PART	SHEET NUMBER	
						2049263333		PDD	000	1 OF 2	

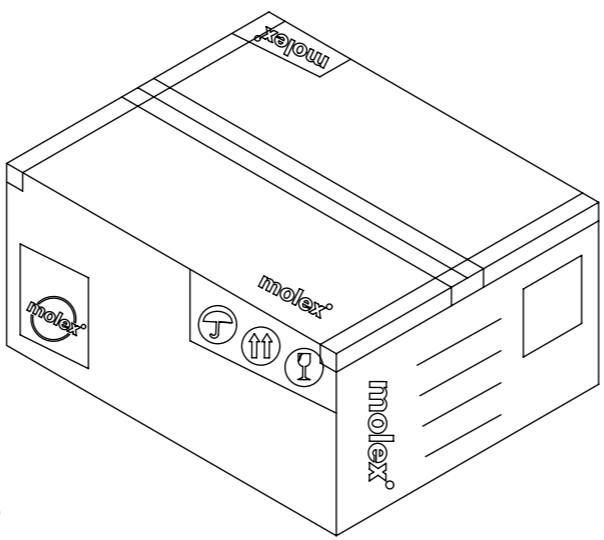
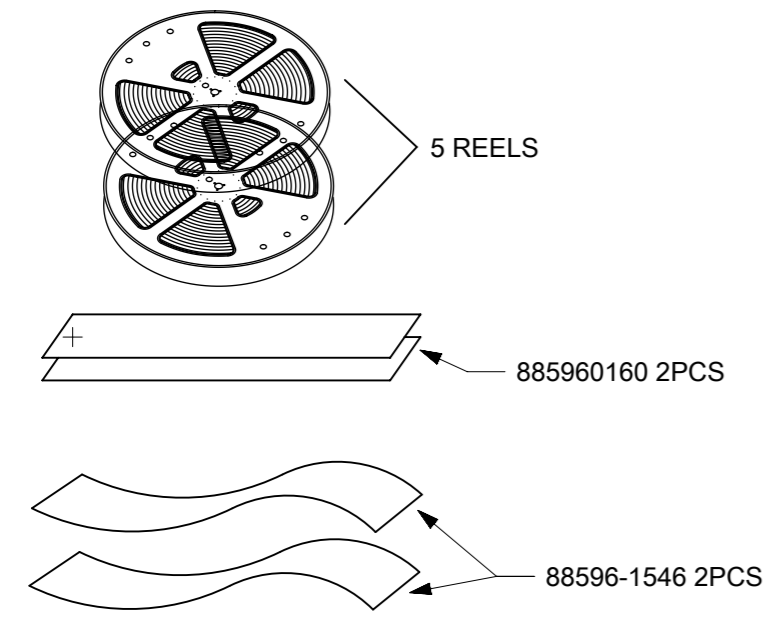
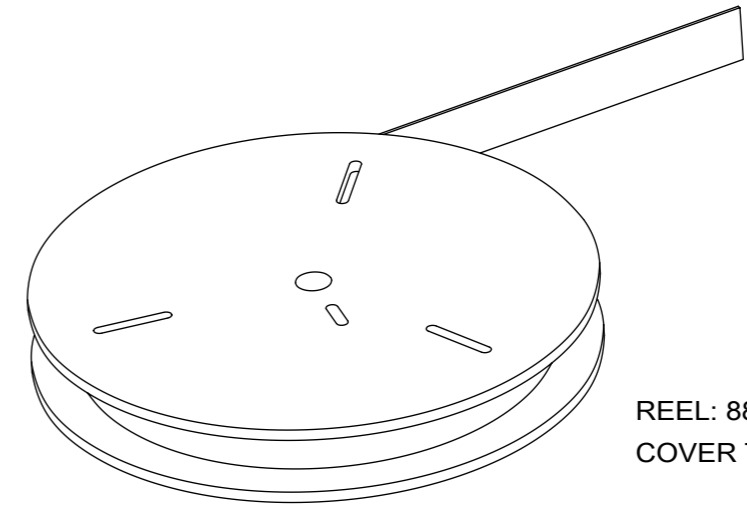
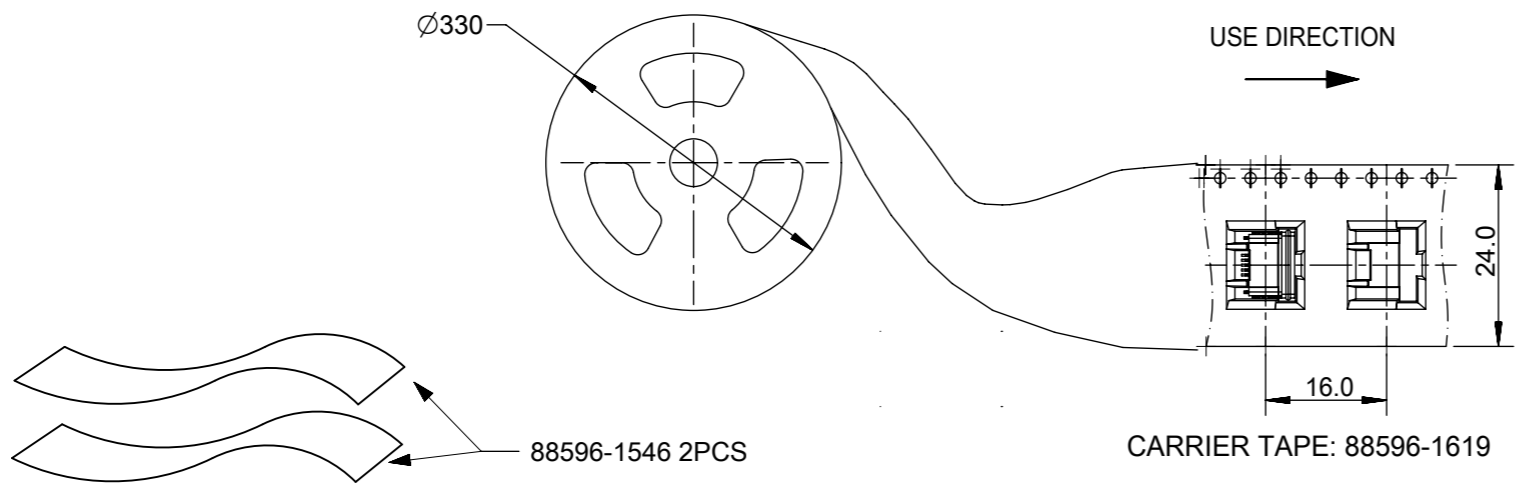

- NOTES:
1. QUANTITY: 700PCS/REEL.
 2. 5 REELS IN A CARTON.
 3. COMPLIANT TO RoHS DIRECTIVE 2011/65/EU AND ELV 2000/53/EC.

204926-1104	3,500PCS	700PCS	5
204926-1103	3,500PCS	700PCS	5
PART NUMBER	PARTS PER SHIPPING CARTON (S.P.Q)	PARTS PER REEL	TOTAL REELS PER CARTON

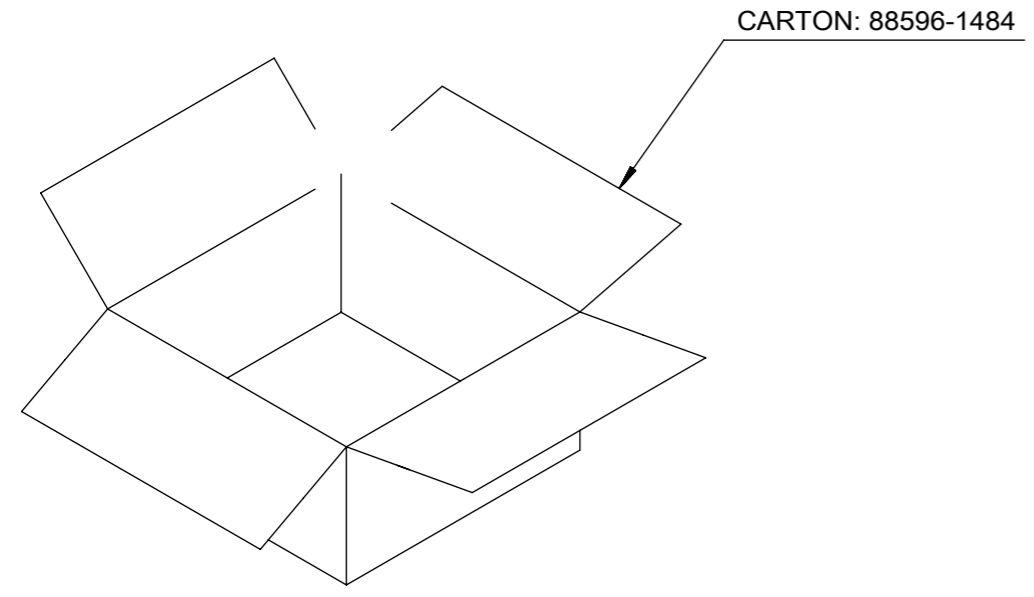

QUALITY SYMBOLS A = 0 E = 0 EP = 0 ▼ = 0 C = 0 ⊗ = 0 ■ = 0 ▽ = 0	THIS DRAWING CONTAINS INFORMATION THAT IS PROPRIETARY TO MOLEX ELECTRONIC TECHNOLOGIES, LLC AND SHOULD NOT BE USED WITHOUT WRITTEN PERMISSION				DIMENSION UNITS: mm SCALE: 1:1				
	EC NO: 171707 DRWN: TLI97 CHK'D: RZHANG APPR: RZHANG	GENERAL TOLERANCES (UNLESS SPECIFIED) ANGULAR TOL ± 3.0 °		DRWN BY: TLI97 DATE: 2017/06/14		PACKAGING DRAWING FOR USB, MICRO-B WATER PROOF			
		4 PLACES ± 3 PLACES ± 2 PLACES ± 0.2 1 PLACE ± 0.25 0 PLACES ±		CHK'D BY: RZHANG DATE: 2017/08/01					PACKAGING DESIGN DRAWING
		DRAFT WHERE APPLICABLE MUST REMAIN WITHIN DIMENSIONS		APPR BY: RZHANG DATE: 2017/08/01		SERIES: 204926	MATERIAL NUMBER: SEE TABLE		
		DRAWING SIZE: A3 THIRD ANGLE PROJECTION		DOCUMENT NUMBER: 2049263333	DOC TYPE: PDD	DOC PART: 000	SHEET NUMBER: 2 OF 2		