

**MATERIAL**

Polyamide based (PA) technopolymer, black colour, matte finish.

**CLOSING CAP**

Polypropylene based (PP) technopolymer, orange or black colour, glossy finish with matte central surface, snap-in mounting.

**STANDARD EXECUTION**

Assembly by means of hexagon head screws or standard lock nuts (not supplied) to put in place inside the knob by pressing.

**SPECIAL EXECUTIONS ON REQUEST**

- On the surface of the closing cap words, marks, graphic symbols, etc. can be tamppointed in colours.

**ASSEMBLY INSTRUCTIONS**

1. The base of the knob should rest on a flat surface.
2. Insert the screw or the lock nut into the knob hole by means of a thrust tool.
3. Push until the insert is completely fitted in.
4. Assemble the snap-in closing cap.



FM design

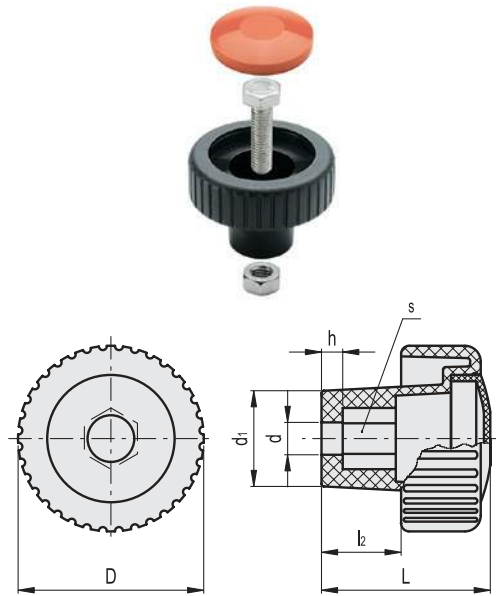

Conversion Table					
1 mm = 0.039 inch					
D		d		s	
mm	inch	mm	inch	mm	inch
35	1,38	5	0.20	8	0.31
50	1,97	6	0.24	10	0.39
70	2,76	8	0.31	13	0.51
		10	0.39	17	0.65
		12	0.47	19	0.74
		14	0.55	22	0.86



C2  
RAL2004

C9  
RAL9005

Code	Description	D	d	L	d1	l2	h	s	♻️
138711	MCT.35 EH-5-C2	35	5	32	18	15	4	8	12
138712	MCT.35 EH-5-C9	35	5	32	18	15	4	8	12
138721	MCT.35 EH-6-C2	35	6	32	18	15	4	10	11
138722	MCT.35 EH-6-C9	35	6	32	18	15	4	10	11
138731	MCT.35 EH-8-C2	35	8	32	18	15	4	13	10
138732	MCT.35 EH-8-C9	35	8	32	18	15	4	13	10
138751	MCT.50 EH-6-C2	50	6	40	23	21	5	10	23
138752	MCT.50 EH-6-C9	50	6	40	23	21	5	10	23
138761	MCT.50 EH-8-C2	50	8	40	23	21	5	13	22
138762	MCT.50 EH-8-C9	50	8	40	23	21	5	13	22
138771	MCT.50 EH-10-C2	50	10	40	23	21	5	17	21
138772	MCT.50 EH-10-C9	50	10	40	23	21	5	17	21
138791	MCT.70 EH-8-C2	70	8	71	30.5	40	9	13	64
138792	MCT.70 EH-8-C9	70	8	71	30.5	40	9	13	64
138801	MCT.70 EH-10-C2	70	10	71	30.5	40	9	17	63
138802	MCT.70 EH-10-C9	70	10	71	30.5	40	9	17	63
138811	MCT.70 EH-12-C2	70	12	71	30.5	40	9	19	62
138812	MCT.70 EH-12-C9	70	12	71	30.5	40	9	19	62
138821	MCT.70 EH-14-C2	70	14	71	30.5	40	9	22	61
138822	MCT.70 EH-14-C9	70	14	71	30.5	40	9	22	61

**RIGHT ASSEMBLY**

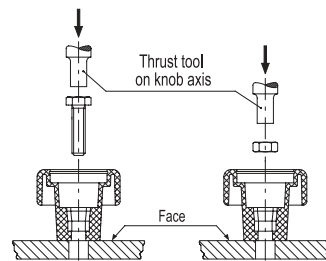

**WRONG ASSEMBLY**

