

# BMI270

6-axis, smart, low-power Inertial Measurement Unit for high-performance applications



## BMI270 – Data sheet

Document revision	1.2
Document release date	June 2020
Document number	BST-BMI270-DS000-04
Technical reference code	0 273 017 008
Notes	Data and descriptions in this document are subject to change without notice. Product photos and pictures are for illustration purposes only and may differ from the real product appearance

# Basic Description

## BMI270

The device is a highly integrated, low power inertial measurement unit (IMU) that combines precise acceleration and angular rate (gyroscopic) measurement with intelligent on-chip motion-triggered interrupt features.

BMI270 integrates:

- 16-bit digital, triaxial accelerometer with  $\pm 2g/\pm 4g/\pm 8g/\pm 16g$  range
- 16-bit digital, triaxial gyroscope with  $\pm 125dps/\pm 250dps/\pm 500dps/\pm 1000dps/\pm 2000dps$  range

### Key features

- Compact standard size LGA mold package, 14 pins, footprint 2.5x3.0mm<sup>2</sup> height 0.83mm
- Output data rates (ODR): 25 Hz ... 6.4 kHz (gyroscope) and 0.78 Hz ... 1.6 kHz (accelerometer)
- Programmable low-pass filter (accelerometer | gyroscope): bandwidth 5.5 | 11 ... 740 | 751 Hz
- Wide power supply range: Analog VDD 1.71V ... 3.6V and independent VDDIO 1.2V...3.6V
- Ultra-low current consumption: typ. 685  $\mu$ A (in full ODR and aliasing free operation)
- Performance mode for gyroscope to minimize noise level: typ. < 7 mdps / $\sqrt$ Hz.
- Built-in power management unit (PMU) for advanced power management and low power modes
- Rapid startup time: 2 ms for gyroscope (in fast start mode) and 2 ms for accelerometer
- Freely configurable secondary digital interface
  - 400 kHz I<sup>2</sup>C (Fm) master interface hub for 1 I2C AUX sensor (e.g. ext. magnetometer, pressure)
    - data synchronized to IMU
  - 10 MHz slave SPI (4-wire, 3-wire) for high speed, calibration free OIS / Dual OIS (SPI) applications
    - Up to 6.4 kHz ODR, control register access and down to 680  $\mu$ s group delay
    - Connectible latency optimized low pass-filters with programmable cut-off frequencies
- 2 KB on-chip FIFO buffer for accelerometer, gyroscope, timestamps, and AUX sensor data
- Fast offset error compensation for accelerometer and gyroscope
- Fast sensitivity error compensation for gyroscope (CRT, reducing the error down to typ. 0.4%)
- HW synchronization of accelerometer, gyroscope, and AUX sensor (< 1  $\mu$ s)
- Sensortime stamps for accurate system (host) and sensor (IMU) time synchronization (<40  $\mu$ s)
- 2 independent programmable I/O pins for interrupt and synchronization events
- RoHS compliant, halogen and lead free
- BMI270 Features
  - Significant motion/Any motion/Motion detect/No motion/Stationary detect/Wrist wear wakeup/Wrist worn step counter and detector/Activity change recognition/Push arm down/Pivot up/Wrist jiggle/Flick in /out

## Typical Applications

- Wearables
- Hearables
- Smart clothing
- Augmented / virtual reality (AR/VR)
- Activity & Context Recognition

## Target Devices

- Fitness trackers, wristbands, smart watches
- Earbuds, ankle bands, neck bands
- Smart clothes
- Augmented and virtual reality glasses and controllers

## Table of contents

<b>1. Specifications .....</b>	<b>8</b>
<b>2. Absolute maximum ratings .....</b>	<b>14</b>
<b>3. Quick Start Guide .....</b>	<b>15</b>
<b>4. Functional Description and Features .....</b>	<b>21</b>
4.1. System Configurations .....	21
4.2. Block Diagram .....	22
4.3. Supply Voltage and Power Management .....	22
4.4. Power-On-Reset (POR) and Device Initialization.....	23
4.5. Power Modes.....	24
4.6. Sensor Data.....	26
4.7. FIFO.....	33
4.8. Advanced Features .....	42
Global Configuration .....	42
Anymotion Detection .....	44
Nomotion Detection .....	46
Significant Motion Detection .....	48
Activity and Activity Change Recognition .....	48
Wrist Wear Wakeup .....	49
Wrist Wear Navigation Gesture Detector .....	51
Step counter / detector (Wrist-worn).....	54
4.9. General Interrupt Pin Configuration.....	55
4.10.Auxiliary Sensor Interface.....	56
4.11.OIS Interface.....	61
4.12.Sensor Self-Test .....	64
4.13.Offset Compensation .....	66
4.14.Sensitivity Error Compensation .....	68

4.15. Non-Volatile Memory .....	69
4.16. Error Reporting .....	70
4.17. Soft-Reset .....	70
<b>5. Register Description .....</b>	<b>71</b>
5.1. General Remarks .....	71
5.2. Register Map .....	72
<b>6. Digital Interfaces .....</b>	<b>127</b>
6.1. Interfaces .....	127
6.2. Primary Interface .....	128
6.3. Primary Interface Digital Protocol Selection .....	129
6.4. Primary Interface SPI .....	129
6.5. Primary Interface I <sup>2</sup> C .....	134
6.6. Secondary Interface .....	138
<b>7. Pinout and Connection Diagram .....</b>	<b>140</b>
7.1. Pin-out .....	140
7.2. Connection Diagrams without Secondary Interface .....	143
7.3. Connection Diagrams with I2C Auxiliary Interface .....	145
7.4. Connection Diagrams with OIS Interface .....	147
<b>8. Package .....</b>	<b>150</b>
8.1. Package outline dimensions .....	150
8.2. Sensing axis orientation .....	151
8.3. Landing pattern recommendation .....	153
8.4. Marking .....	154
8.5. Soldering guidelines .....	155
8.6. Handling instructions .....	155
8.7. Environmental safety .....	155

- 9. Legal disclaimer ..... 156**
  - 9.1. Engineering samples .....156
  - 9.2. Product use.....156
  - 9.3. Application examples and hints .....156
  
- 10.Document history and modifications ..... 157**

Table 1: Basic electrical parameter specifications .....	8
Table 2: Accelerometer characteristics .....	9
Table 3: Gyroscope Characteristics .....	11
Table 4: Electrical characteristics temperature sensor .....	13
Table 5: Absolute maximum ratings .....	14
Table 6: Power Modes.....	24
Table 7: Cutoff freq. of the accelerometer according to ODR, Normal & Performance Mode .....	26
Table 8: Accelerometer noise according to ODR, Normal & Performance Mode, +/- 8g range .....	26
Table 9: Accelerometer group delay according to ODR, Normal & Performance Mode.....	27
Table 10: Cutoff frequency of the gyroscope according to ODR, Normal & Performance Mode.....	28
Table 11: Gyroscope noise according to ODR, Normal Mode, +/- 2000 dps range .....	28
Table 12: Gyroscope noise according to ODR, Performance Mode, +/- 2000 dps range .....	29
Table 13: Gyroscope group delay according to ODR, Normal and Performance Modes .....	29
Table 14: Positive use-case scenarios for the wrist wear wakeup gestures.....	50
Table 15: Step counter Configuration.....	54
Table 16: OIS Register Map .....	62
Table 17: Mapping for primary interface.....	128
Table 18: Electrical specifications of the interface pins.....	128
Table 19: Timing specifications for SPI .....	129
Table 20: Timing specification for I <sup>2</sup> C of the device .....	134
Table 21: Mapping of the device pins for secondary interface .....	138
Table 22: Pin-out and pin connections .....	141
Figure 1: Any-motion detection .....	45
Figure 2: No-motion detection .....	47
Figure 3: Device co-ordinate system assumed for gesture detection .....	49
Figure 4: Flick-in/out movement .....	51
Figure 5: Push arm-down/pivot up .....	52
Figure 6: Wrist Jiggle .....	52
Figure 7: 9-DOF Solution w/ magnetometer (AUX) connected to the 2 <sup>nd</sup> I/F .....	56
Figure 8: OIS interface .....	61
Figure 9: Digital Interfaces.....	127
Figure 10: SPI timing diagram .....	130
Figure 11: I <sup>2</sup> C timing diagram.....	135

# 1. Specifications

Unless stated otherwise, the given values are over lifetime, operating temperature and voltage ranges. Minimum/maximum values are  $\pm 3\sigma$ .

Table 1: Basic electrical parameter specifications

OPERATING CONDITIONS						
Parameter	Symbol	Condition	Min	Typ	Max	Unit
Supply Voltage Core Domain	V <sub>DD</sub>		1.71	1.8	3.6	V
Supply Voltage I/O Domain	V <sub>DDIO</sub>		1.2	1.8	3.6	V
Voltage Input Low Level	V <sub>IL</sub>	SPI & I <sup>2</sup> C			0.3V <sub>DDIO</sub>	-
Voltage Input High Level	V <sub>IH</sub>	SPI & I <sup>2</sup> C	0.7V <sub>DDIO</sub>			-
Voltage Output Low Level	V <sub>OL</sub>	V <sub>DDIO</sub> ≥ 1.62V, I <sub>OL</sub> ≤ 2mA, SPI			0.2V <sub>DDIO</sub>	-
		V <sub>DDIO</sub> < 1.62V, I <sub>OL</sub> ≤ 1.5mA, SPI			0.2V <sub>DDIO</sub>	
Voltage Output High Level	V <sub>OH</sub>	V <sub>DDIO</sub> ≥ 1.62V, I <sub>OH</sub> ≤ 2mA, SPI	0.8V <sub>DDIO</sub>			-
		V <sub>DDIO</sub> ≤ 1.62V, I <sub>OH</sub> ≤ 1.5mA, SPI	0.8V <sub>DDIO</sub>			
Current consumption	I <sub>DD</sub>	A+G Performance Mode V <sub>DD</sub> = 1.8 V, T <sub>A</sub> = 25°C, ODR <sub>max</sub>		970		μA
		A+G Normal Mode V <sub>DD</sub> = 1.8 V, T <sub>A</sub> = 25°C, ODR <sub>max</sub>		685		
		A+G Low Power Mode V <sub>DD</sub> = 1.8 V, T <sub>A</sub> = 25°C, ODR <sub>25Hz</sub>		420		
		A <sub>only</sub> Normal Mode V <sub>DD</sub> = 1.8 V, T <sub>A</sub> = 25°C, ODR <sub>max</sub>		210		
		A <sub>only</sub> Low Power Mode V <sub>DD</sub> = 1.8 V, T <sub>A</sub> = 25°C, ODR <sub>25Hz</sub>		10		
		A+G Suspend mode, V <sub>DD</sub> = 1.8 V, T <sub>A</sub> = 25°C		3.5		
		Advanced features V <sub>DD</sub> = 1.8 V, T <sub>A</sub> = 25°C, depends on enabled feature set		3		



Power on time	t <sub>PO</sub>	Time from supply “on” to SPI or I2C I/F operational			2	ms
Non-volatile memory (NVM) write-cycles	nNVM	Using nvm_prog cmd			14	cycles
Operating Temperature	T <sub>A</sub>		-40		+85	°C

Table 2: Accelerometer characteristics

OPERATING CONDITIONS ACCELEROMETER						
Parameter	Symbol	Condition	Min	Typ	Max	Units
Acceleration Range	g <sub>FS2g</sub>	Selectable via serial digital interface		±2		g
	g <sub>FS4g</sub>			±4		g
	g <sub>FS8g</sub>			±8		g
	g <sub>FS16g</sub>			±16		g
Start-up time	t <sub>A,SU</sub>	suspend to normal mode VDD= 1.8 V, T <sub>A</sub> =25°C, ODR <sub>max</sub>		2		ms

OUTPUT SIGNAL ACCELEROMETER						
Parameter	Symbol	Condition	Min	Typ	Max	Units
Resolution				16		bit
Sensitivity	S <sub>2g</sub>	g <sub>FS2g</sub> , T <sub>A</sub> =25°C		16384		LSB/g
	S <sub>4g</sub>	g <sub>FS4g</sub> , T <sub>A</sub> =25°C		8192		LSB/g
	S <sub>8g</sub>	g <sub>FS8g</sub> , T <sub>A</sub> =25°C		4096		LSB/g
	S <sub>16g</sub>	g <sub>FS16g</sub> , T <sub>A</sub> =25°C		2048		LSB/g
Sensitivity Error	S <sub>A,err_8g</sub>	T <sub>A</sub> =25°C, nominal V <sub>DD</sub> soldered, over life time		±0.4		%
Sensitivity Temperature Drift	TCS <sub>A</sub>	full T <sub>A</sub> range, nominal V <sub>DD</sub> best fit straight line		0.004		%/K
Sensitivity Supply Volt. Drift	S <sub>A,VDD</sub>	T <sub>A</sub> =25°C, full V <sub>DD</sub> range soldered, over life time		0.0001		%/V
Zero-g Offset	Off <sub>A,life</sub>	T <sub>A</sub> =25°C, nominal V <sub>DD</sub> soldered, over life time		±20		mg
Zero-g Offset Temperature Drift	TCO <sub>A</sub>	full T <sub>A</sub> range, nominal V <sub>DD</sub> best fit straight line		±0.25		mg/K
Zero-g Offset Supply Volt. Drift	Off <sub>A,VDD</sub>	T <sub>A</sub> =25°C, full V <sub>DD</sub> range soldered, over life time		<0.5		mg/V
Power supply rejection ratio	Off_PSR R <sub>A</sub>	100Hz – 1 MHz sine wave, 50mV		<8		mg/50mV

Output Noise	$n_{A,nd}$	Normal mode $T_A = 25^\circ\text{C}$ , nominal $V_{DD}$ , range = 8g		0.16		mg/ $\sqrt{\text{Hz}}$
	$n_{A,rms}$	Normal mode $T_A = 25^\circ\text{C}$ , nominal $V_{DD}$ , BW = 80 Hz ODR = 200 Hz range = 8g		1.51		mg-rms
Nonlinearity	NLA	$T_A = 25^\circ\text{C}$ , nominal $V_{DD}$ , best fit straight line $g_{FS2g}$		0.5		%FS
Output Data Rate	ODR <sub>A,n</sub>	Normal mode	12.5		1600	Hz
	ODR <sub>A,lpm</sub>	Low-power mode	0.78		400	
ODR Accuracy	OAcy <sub>A,n</sub>	Normal mode, variation part to part, $T_A = 25^\circ\text{C}$ , nominal $V_{DD}$ , Accel only operation			1	%
		Normal mode, variation part to part, $T_A = 25^\circ\text{C}$ , nominal $V_{DD}$ , IMU operation			1.7	
	OAcy <sub>A,n,T</sub>	Normal mode, variation full $T_A$ range, same part nominal $V_{DD}$ , Accel only operation		0.03		%K
		Normal mode, variation full $T_A$ range, same part nominal $V_{DD}$ , IMU operation		0.0037		
Bandwidth (BW) in normal mode	ODR <sub>A,12.5</sub>	3dB cutoff frequency of the accelerometer $T_A = 25^\circ\text{C}$ , nominal $V_{DD}$ ,  Filter setting [acc_bwp] = 0x02		5.5		Hz
	ODR <sub>A,25</sub>			11		
	ODR <sub>A,50</sub>			22		
	ODR <sub>A,100</sub>			44		
	ODR <sub>A,200</sub>			89		
	ODR <sub>A,400</sub>			178		
	ODR <sub>A,800</sub>			343		
	ODR <sub>A,1600</sub>			740		

MECHANICAL CHARACTERISTICS ACCELEROMETER						
Parameter	Symbol	Condition	Min	Typ	Max	Units
Cross Axis Sensitivity	SX <sub>A</sub>	Relative contribution between any two of the three axes		1		%
Alignment Error	E <sub>A</sub>	Relative to package outline		0.5		°
Zero-g offset over PCB strain	Off <sub>A,PCB</sub>	T <sub>A</sub> =25°C, nominal V <sub>DD</sub> soldered, Ø 5 parts		±0.010		mg/μstrain

Table 3: Gyroscope Characteristics

OPERATING CONDITIONS GYROSCOPE						
Parameter	Symbol	Condition	Min	Typ	Max	Unit
Range	R <sub>FS125</sub>	Selectable via serial digital interface		125		dps
	R <sub>FS250</sub>			250		dps
	R <sub>FS500</sub>			500		dps
	R <sub>FS1000</sub>			1,000		dps
	R <sub>FS2000</sub>			2,000		dps
Start-up time	t <sub>G,SU</sub>	suspend to normal mode repeated, V <sub>DD</sub> = 1.8 V, T <sub>A</sub> =25°C, ODR <sub>max</sub>		45		ms
	t <sub>G,FSU</sub>	fast start mode V <sub>DD</sub> = 1.8 V, T <sub>A</sub> =25°C, ODR <sub>max</sub>		2		

OUTPUT SIGNAL GYROSCOPE						
Resolution				16		bit
Sensitivity	R <sub>FS2000</sub>	T <sub>a</sub> =25°C		16.384		LSB/dps
	R <sub>FS1000</sub>	T <sub>a</sub> =25°C		32.768		LSB/dps
	R <sub>FS500</sub>	T <sub>a</sub> =25°C		65.536		LSB/dps
	R <sub>FS250</sub>	T <sub>a</sub> =25°C		131.072		LSB/dps
	R <sub>FS125</sub>	T <sub>a</sub> =25°C		262.144		LSB/dps
Sensitivity Error	S <sub>G_err</sub>	T <sub>A</sub> =25°C, nominal V <sub>DD</sub> soldered, over life time		±2		%
	S <sub>G_err_CR T</sub>	T <sub>A</sub> =25°C, nominal V <sub>DD</sub> soldered, after CRT <sup>1</sup>		±0.4		
Sensitivity Temperature Drift	TCS <sub>G</sub>	full T <sub>A</sub> range, nominal V <sub>DD</sub> best fit straight line		0.02		%/K

<sup>1</sup> See section 4.14 for details.

Sensitivity Supply Volt. Drift	$S_{G,VDD}$	$T_A=25^\circ\text{C}$ , full $V_{DD}$ range soldered, over life time		0.0005		%/V
Zero-rate offset	$\Omega_{oL}$	$T_A=25^\circ\text{C}$ , nominal $V_{DD}$ soldered, over life time		$\pm 0.5$		dps
Zero-rate offset change over temperature	$TCO_G$	Nominal $V_{DD}$ supplies best fit straight line		$\pm 0.015$		dps / K
Zero-rate offset Supply Volt. Drift	$Off_{G,VDD}$	$T_A=25^\circ\text{C}$ , full $V_{DD}$ range soldered, over life time		0.02		dps / V
Power supply rejection ratio	$Off_{PS}$ $RR_G$	100 Hz – 1 MHz sine wave, 50mV		0.40		dps / 50mV
Output Noise	$n_{G,nd}$	Performance mode $T_A=25^\circ\text{C}$ , nominal $V_{DD}$		0.007		dps / $\sqrt{\text{Hz}}$
		Normal mode $T_A=25^\circ\text{C}$ , nominal $V_{DD}$		0.010		dps / $\sqrt{\text{Hz}}$
	$n_{G,rms}$	Performance mode $T_A=25^\circ\text{C}$ , nominal $V_{DD}$ , BW = 74.6 Hz ODR = 200 Hz		0.07		dps-rms
		Normal mode $T_A=25^\circ\text{C}$ , nominal $V_{DD}$ , BW = 74.6 Hz ODR = 200 Hz		0.09		dps-rms
Nonlinearity	$NL_G$	$T_A=25^\circ\text{C}$ , nominal $V_{DD}$ , best fit straight line $R_{FS250}$ , $R_{FS2000}$		0.01		% FS
Output Data Rate	$ODR_{G,n,h}$ $p$	Normal and performance mode	25		6400	Hz
	$ODR_{G,lp}$ $m$	Low-power mode	25		100	
ODR Accuracy	$OAcy_{G,n}$	Normal and performance mode, $T_A=25^\circ\text{C}$ , nominal $V_{DD}$			1.7	%
	$OAcy_{G,n}$ $T$	Normal mode, full $T_A$ range, same part, nominal $V_{DD}$		0.0037		%/K
Bandwidth (BW) in normal and performance mode	$ODR_{G,25}$	3dB cutoff frequency of the gyroscope, $T_A=25^\circ\text{C}$ , nominal $V_{DD}$  Filter setting [gyr_bwp] = 0x02		11		Hz
	$ODR_{G,50}$			20		
	$ODR_{G,10}$ $0$			39		
	$ODR_{G,20}$ $0$			77		
	$ODR_{G,40}$ $0$			152		
	$ODR_{G,80}$ $0$			300		

	ODR <sub>G,16</sub> 00			557		
	ODR <sub>G,32</sub> 00			751		
	ODR <sub>G,64</sub> 00			712		

MECHANICAL CHARACTERISTICS GYROSCOPE						
Parameter	Symbol	Condition	Min	Typ	Max	Units
Cross Axis Sensitivity	SX <sub>G</sub>	Relative contribution between any two of the three axes <sup>2</sup>		0.2		%
Alignment Error	E <sub>A</sub>	Relative to package outline		0.5		°
Zero-rate offset over PCB strain	Off <sub>G, PCB</sub>	T <sub>A</sub> =25°C, nominal V <sub>DD</sub> soldered, Ø 5 parts		±1.5		mdps / µstrain
g-Sensitivity		Sensitivity to static acceleration stimuli in all three axis			0.1	dps / g

Table 4: Electrical characteristics temperature sensor

OPERATING CONDITIONS AND OUTPUT SIGNAL OF TEMPERATURE SENSOR						
Parameter	Symbol	Condition	Min	Typ	Max	Units
ADC Resolution				16		bits
Temperature Sensor Measurement Range	T <sub>S</sub>		-41		87	°C
Output at 23 °C				0		LSB
Sensitivity	S <sub>T</sub>			512		LSB/K
Output Data Rate Temperature Sensor	ODR <sub>T,G</sub>	Normal mode and performance mode, T <sub>A</sub> =25°C, nominal V <sub>DD</sub> , Gyroscope on			100	Hz
	ODR <sub>T</sub>	All other modes incl. low power mode			0.78	
ODR Accuracy Temperature Sensor	OAcy <sub>T,G</sub>	Normal mode and performance mode, T <sub>A</sub> =25°C, nominal V <sub>DD</sub> , Gyroscope on		<1.5		%
	OAcy <sub>T</sub>	All other modes incl. low power mode		1.5		

<sup>2</sup> For details see section 4.6 Gyroscope DataPost-Processing

## 2. Absolute maximum ratings

Stress above these limits may cause damage to the device. Exceeding the specified electrical limits may affect the device reliability or cause malfunction.

Table 5: Absolute maximum ratings

PARAMETER	CONDITION	MIN	MAX	UNITS
Voltage at Supply Pin	V <sub>DD</sub> Pin	-0.3	4	V
	V <sub>DDIO</sub> Pin	-0.3	4	V
Voltage at any Logic Pin	Non-Supply Pin	-0.3	V <sub>DDIO</sub> +0.3, <4	V
Passive Storage Temp. Range	≤ 65% rel. H.	-50	+150	°C
Non-volatile memory (NVM) Data Retention	T = 85°C, after 15 cycles	10		y
Mechanical Shock	Duration ≤ 200µs		10,000	g
	Duration ≤ 1.0ms		2,000	g
	Free fall onto hard surfaces		1.8	m
ESD according JESD47	HBM at any pin		2	kV
	CDM		500	V
	MM JESD22A115C		200	V

### 3. Quick Start Guide

The purpose of this section is to help developers who want to start working with the device by giving you some very basic hands-on application examples to get started.

#### Note about using the device

The communication between application processor and the device will happen either over I2C or SPI interface. Each register read operation includes dummy bytes:

- I2C: 0
- SPI: 1

For simplicity the dummy bytes are not shown in the examples below. For more information about the interfaces, see Section 6.

The device is configured for advance power save mode after POR or soft reset. For details on the interface operation in advanced power save mode, see the description of Register [PWR\\_CONF.adv\\_power\\_save](#) in Section 5.

Before starting the test, the device has to be properly connected to the master (AP) and powered up. For more information about it, read the related Section 7.

#### First application setup examples algorithms:

After power up by setting the correct voltage to the appropriate external pins, the device enters automatically into the Power On Reset (POR) sequence. In order to properly make use of the device, certain steps from host processor side are needed. The most typical operations will be explained in the following application examples in form of flow diagrams.

#### 1. Testing communication and initializing the device

- Reading chip id [CHIP\\_ID](#) (0x24) (checking correct communication). The interface is coming up configured for I2C, the initial dummy read configures it to SPI.

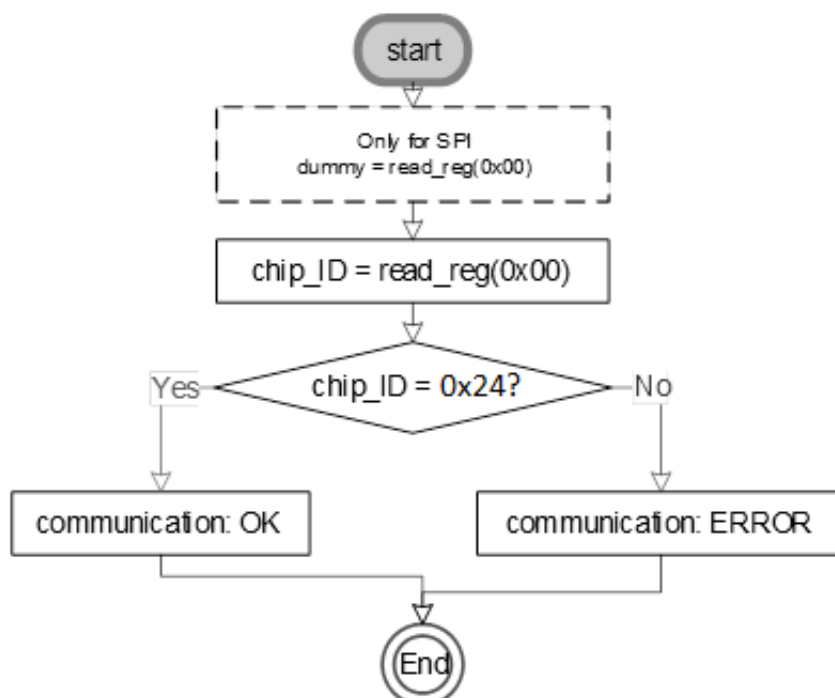

b. Performing initialization sequence<sup>3</sup>

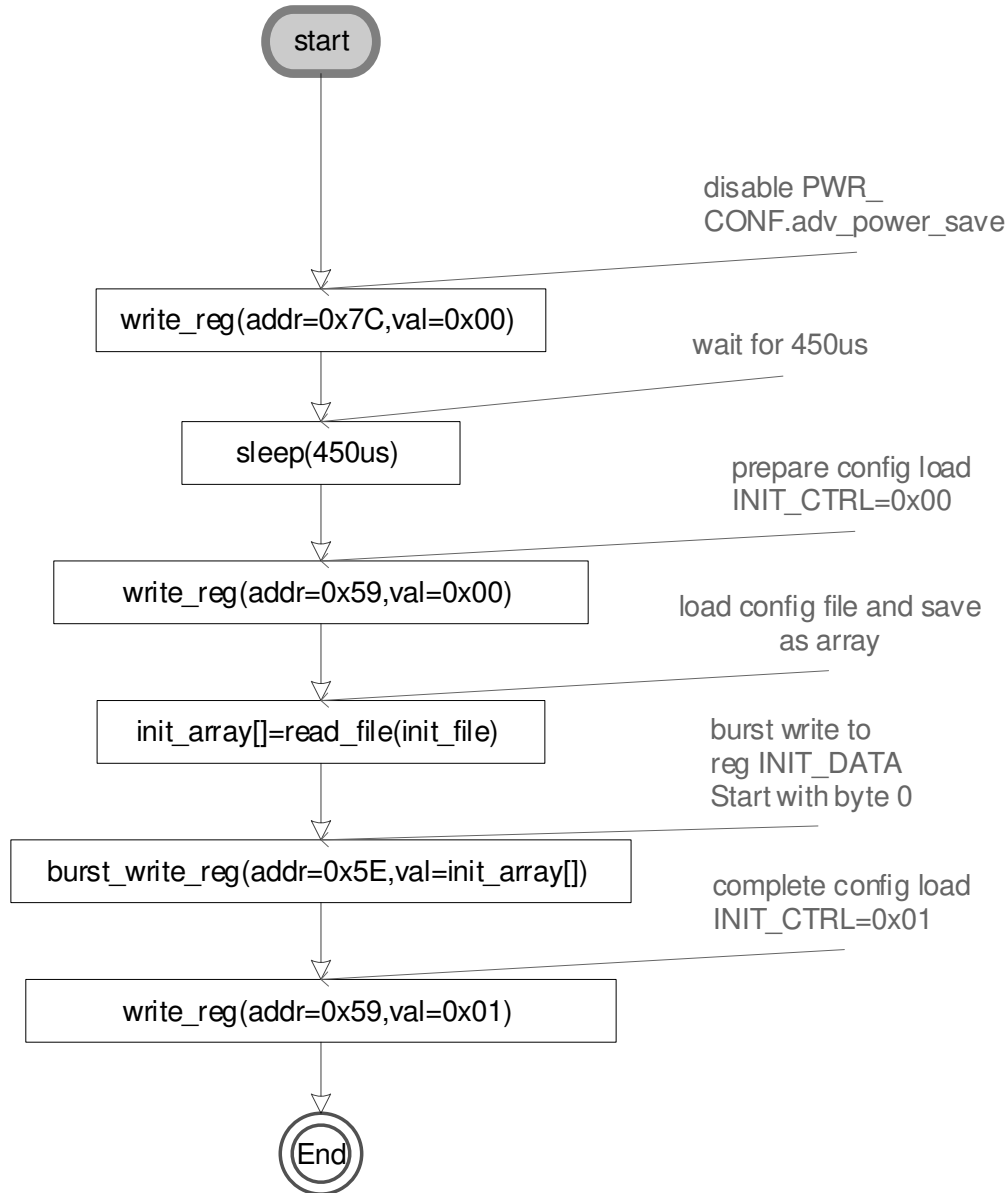

<sup>3</sup> The bmi270\_config\_file in <https://github.com/BoschSensortec/BMI270-Sensor-API/blob/master/bmi270.c>



c. Checking the correct initialization status

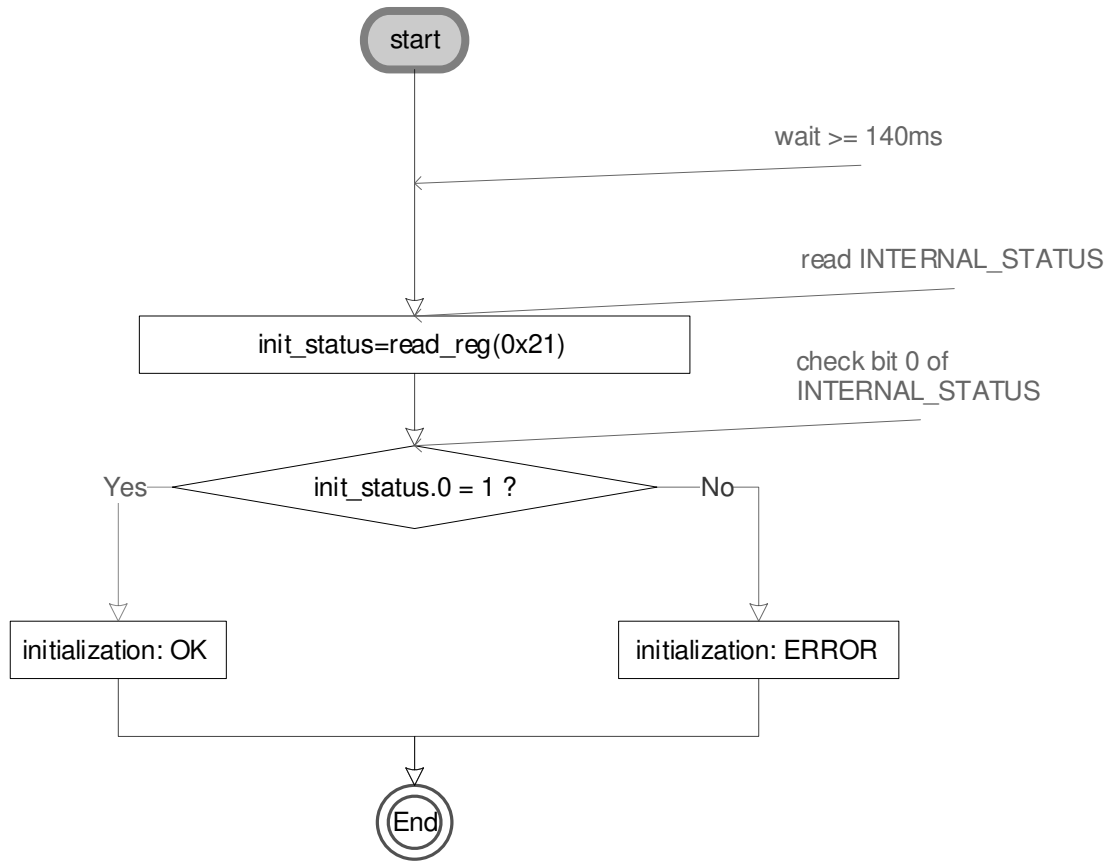

## 2. Configuring the device for low power mode

Setting data processing parameters (power, bandwidth, range) and reading sensor data

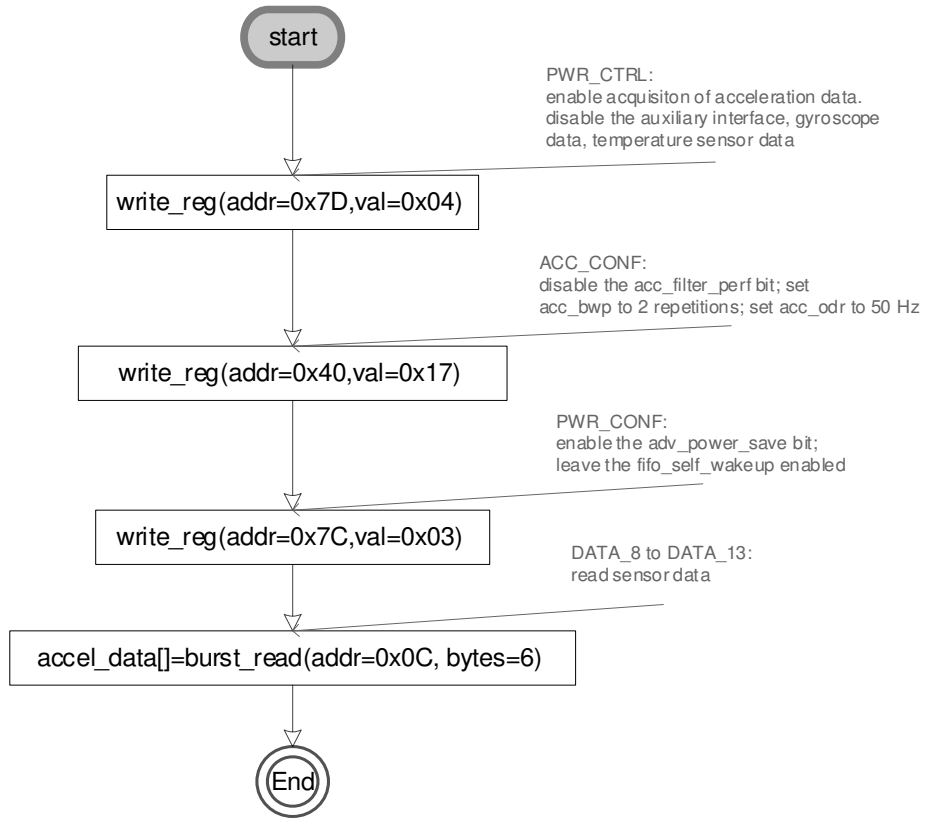

### 3. Configuring the device for normal power mode

Setting data processing parameters (power, bandwidth, range) and reading sensor data

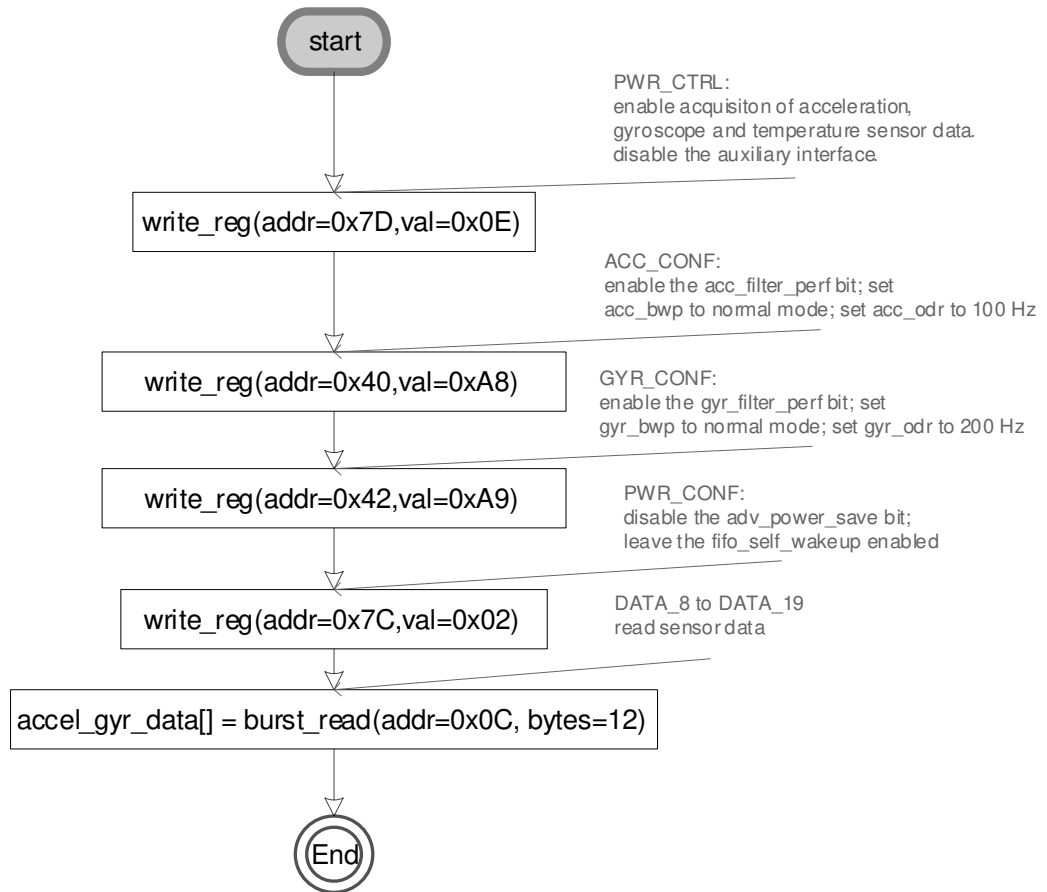

#### 4. Configuring the device for performance mode

Setting data processing parameters (power, bandwidth, range) and reading sensor data

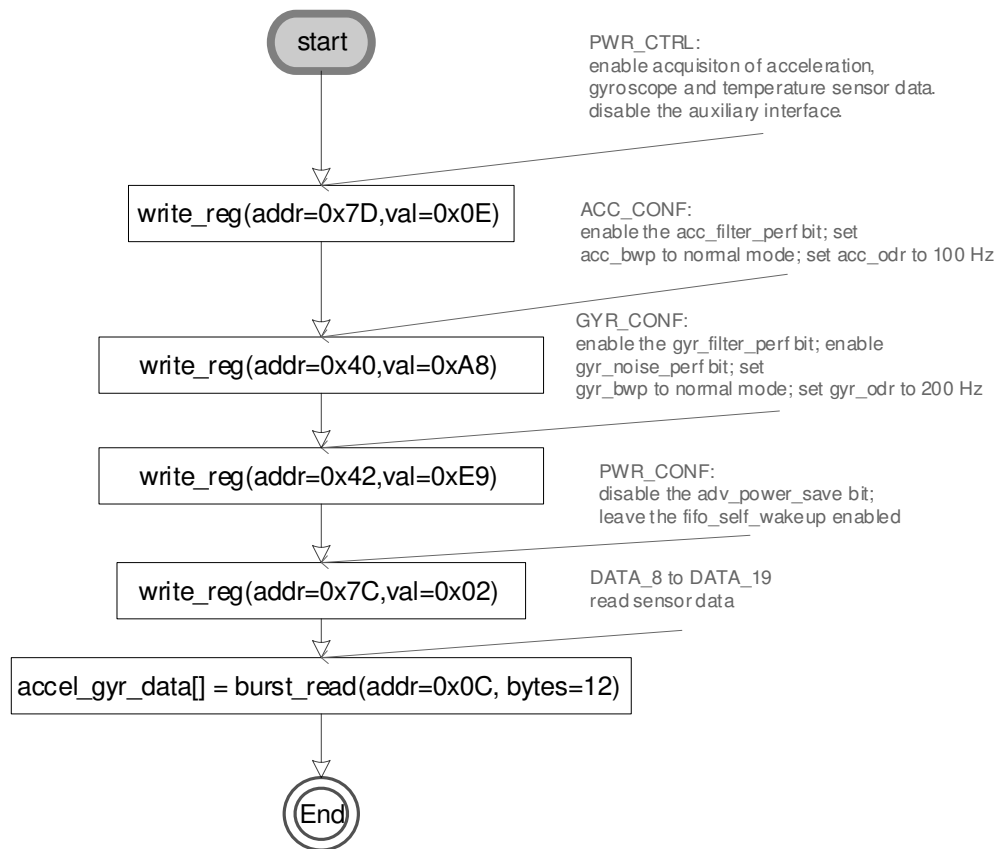

**Further steps:**

The device has additional capabilities that are described in this document and include FIFO, power saving modes, synchronization capabilities with host processor; data synchronization and integration with third-party sensors (see Section 4).

## 4. Functional Description and Features

This section contains references to the registers of the device. A detailed description of the registers including addresses, bit fields, and values is given in Section 5.

### 4.1. System Configurations

The device has 14 external I/F pins and supports the SPI and I2C protocols on its primary interface to the host system. The device supports on its secondary interface (I2C master) an auxiliary sensor configuration (e.g. a magnetometer, see Section 4.10) or an external OIS interface (see Section 4.12). Both configurations work independent of the configuration (SPI/I2C) of the primary interface. If the secondary I/F is configured as AUX I/F, the sensor data of the IMU and the AUX sensor are synchronized.

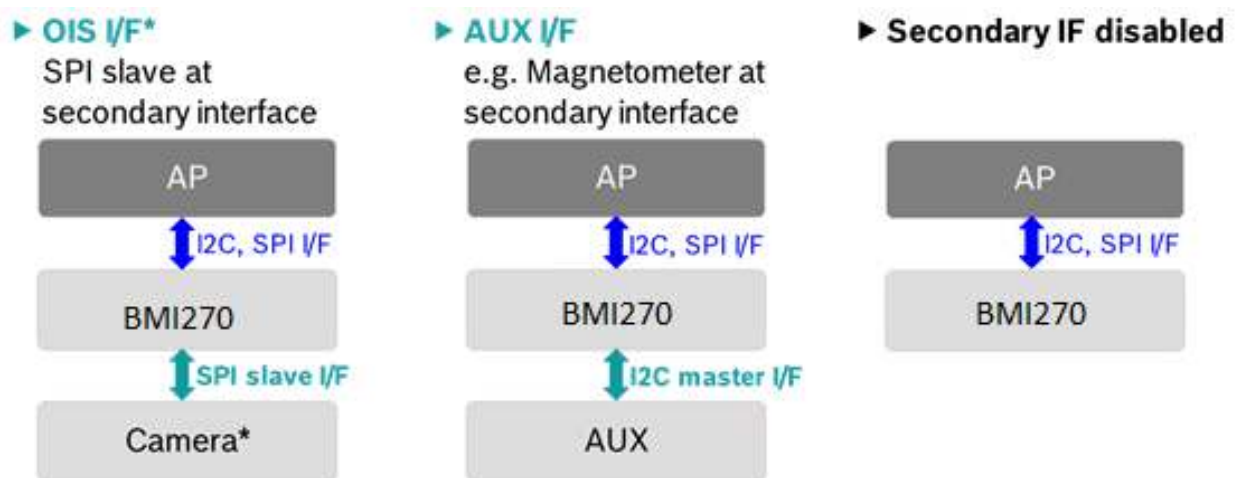

The device includes two sensors, an accelerometer and a gyroscope. The accelerometer measures the direction and magnitude of the force applied to the sensor, reporting zero in a free fall scenario. The gyroscope measures the rotation rate, reporting zero at rest.

## 4.2. Block Diagram

### BMI270

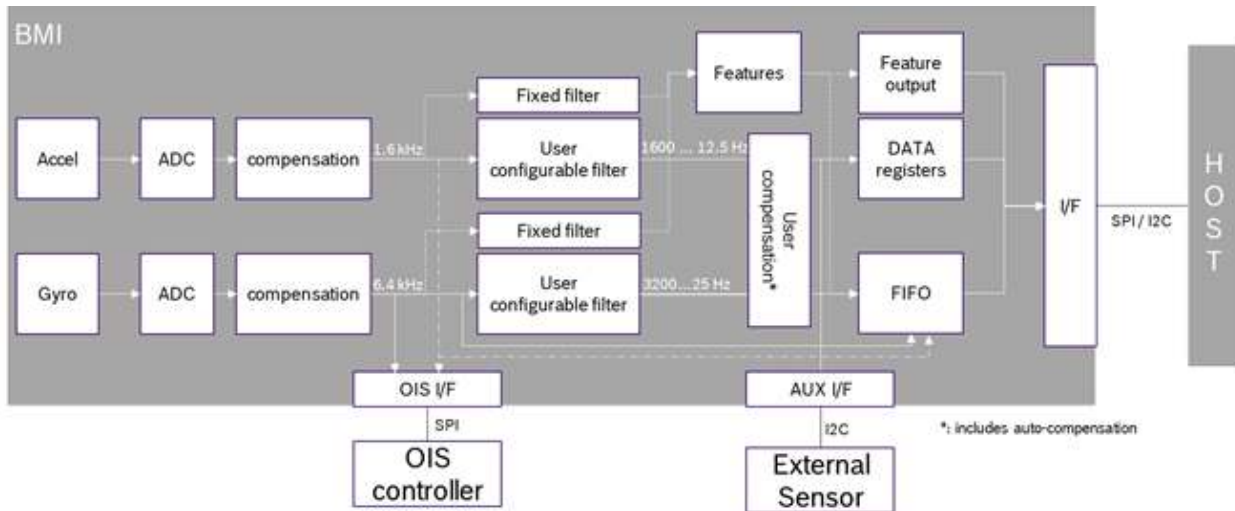

## 4.3. Supply Voltage and Power Management

The device has two distinct power supply pins:

- VDD is the main power supply.
- VDDIO is a separate power supply pin used for supplying power for the interface including the auxiliary interface.

There are no limitations with respect to the voltage level applied to the VDD and VDDIO pins, as long as it lies within the respective operating range. Furthermore, the device can be completely switched off (VDD= 0V) while keeping the VDDIO supply within operating range or vice versa. However, if the VDDIO supply is switched off, all interface pins (CSB, SDX, SCX) must be kept close to GNDIO potential. The device is reset when the supply voltage applied to at least one supply pin VDD or VDDIO falls below the specified minimum values. No constraints exist for the minimum slew-rate of the voltage applied to the VDD and VDDIO pins.

#### 4.4. Power-On-Reset (POR) and Device Initialization

During POR the voltages VDD/VDDIO are ramped to their respective target values. After reaching the target supply voltages, all registers are accessible after a delay of 450 us.

After every POR or soft reset, the IMU remains in suspend mode. To get ready for operation the device must be initialized through the following procedure:

- Disable advanced power save mode: [PWR\\_CONF.adv\\_power\\_save](#) =0b0
- Wait for 450 us (or 12 LSB of [SENSORTIME\\_0](#))
- Write [INIT\\_CTRL.init\\_ctrl](#)=0x00 – to prepare config load
- Upload configuration file
  - Burst write 8 kB initialization data to Register [INIT\\_DATA](#) (start with byte 0 of initialization data)<sup>4</sup>. This requires ca. 6.6 ms at 10 MHz SPI I/F frequency. The configuration file `bmi270_config_file` is available on GitHub (<https://github.com/BoschSensortec/BMI270-Sensor-API/blob/master/bmi270.c>)
  - Optionally: Burst read configuration file from Register [INIT\\_DATA](#) and check correctness by comparing it to the data written to the register in the previous step.
- Write [INIT\\_CTRL.init\\_ctrl](#)=0x01 – to complete config load.  
**Note:** This operation **must not** be performed more than once after POR or soft-reset.
- Wait until Register [INTERNAL\\_STATUS.message](#) contains the value 0b0001. This will happen after at most 20 ms.

After the initialization sequence is completed, the power mode of the device is automatically set to “Configuration mode” (refer to Section 3.2) Now it is possible to switch to other power modes and the device is ready for operation as required and described in the following sections.

---

<sup>4</sup> If the maximum burst write length of the host is less than 8 kB the initialization data can be written in smaller chunks. Between two write operations the Registers [INIT\\_ADDR\\_0](#) and [INIT\\_ADDR\\_1](#) need to be incremented by the length of the first chunk write operation in bytes/2.

### 4.5. Power Modes

The main power modes of the device are:

- Suspend mode: Lowest possible power consumption, while still maintaining its configuration
- Configuration mode: All IMU features accessible at full interface speed
- Low power mode: Motion sensing at lowest possible power consumption
- Normal mode: Aliasing free motion sensing at maximum ODR
- Performance mode: Motion sensing at maximum sensor performance

The table below shows the required configurations for these power modes

Table 6: Power Modes

		<a href="#">PWR_CTRL.acc_en</a>	<a href="#">PWR_CTRL.gyr_en</a>	<a href="#">ACC_CONF.acc_filter_perf</a>	<a href="#">GYR_CONF.gyr_filter_perf</a>	<a href="#">GYR_CONF.gyr_noise_perf</a>	<a href="#">PWR_CONF.adv_power_save</a>	Typ. current consumption * depends on <a href="#">ACC_CONF</a> ** depends on <a href="#">GYR_CONF</a>
Suspend (lowest power mode)		0	0	X	X	X	1	3.5 $\mu$ A
Configuration mode		0	0	X	X	X	0	120 $\mu$ A
Low power mode	Accel only	1	0	0	X	X	1	Down to 4 $\mu$ A*
	Gyro only	0	1	X	0	0		Down to 420 $\mu$ A**
	IMU	1	1	0	0	0		Down to 420 $\mu$ A* **
Normal mode <sup>5</sup>	Accel only	1	0	1	X	X	X	210 $\mu$ A
	Gyro only	0	1	X	1	0		600 $\mu$ A
	IMU	1	1	1	1	0		685 $\mu$ A
Performance mode <sup>5</sup>	Accel only	1	0	1	X	X	X	210 $\mu$ A
	Gyro only	0	1	X	1	1		900 $\mu$ A
	IMU	1	1	1	1	1		970 $\mu$ A

The power state of the IMU is controlled through the registers [PWR\\_CTRL](#) and [PWR\\_CONF](#). The Register [PWR\\_CTRL](#) enables and disables the accelerometer, the gyroscope, the auxiliary sensor, and the temperature sensor. The Register [PWR\\_CONF](#) controls which power state the sensors enter if they are enabled or disabled in the Register [PWR\\_CTRL](#). The power state impacts the behavior of the sensor with respect to start-up time, available functions, etc. but not the sensor data quality.

<sup>5</sup> Accelerometer does not differ in normal and performance mode.



The sensor data quality (e.g. the noise performance and/or the filter characteristics) is controlled in the Register [ACC\\_CONF](#) and Register [GYR\\_CONF](#). In all global power configurations both register contents and FIFO contents are retained.

Table “Power Modes” above shows how to configure the device for the most relevant power modes. But any other combination of the shown register settings is allowed. These registers are described as follows:

[PWR\\_CTRL](#): used to enable and disable sensors (accelerometer, gyroscope, auxiliary, and temperature). Per default, all sensors are disabled.

[PWR\\_CTRL.acc\\_en](#): enable or disable the accelerometer in all power modes.

[PWR\\_CTRL.gyr\\_en](#): enable or disable the gyroscope in all power modes.

[ACC\\_CONF.acc\\_filter\\_perf](#): enable or disable aliasing<sup>6</sup> free acceleration sensing.

[GYR\\_CONF.gyr\\_filter\\_perf](#): enable or disable aliasing<sup>6</sup> free yaw rate sensing.

[GYR\\_CONF.gyr\\_noise\\_perf](#): enable or disable low noise mode for precision yaw rate sensing.

[PWR\\_CONF.adv\\_power\\_save](#): enable or disable the advanced power save configuration. If the device is configured for accelerometer only operation and [ACC\\_CONF.acc\\_filter\\_perf](#)=0b0 or all sensors are disabled, there is a potential for additional (maximal) power saving. If the configuration is set by [PWR\\_CONF.adv\\_power\\_save](#)=0b1, the devices internally reduces the power consumption always to a minimum without compromising data quality defined by the performance parameters set above at the expense of these restrictions which apply:

- Register writes need an inter-write-delay of at least 450  $\mu$ s.
- The sensors log data into the FIFO in all power modes. The user needs to disable advanced power save mode ([PWR\\_CONF.adv\\_power\\_save](#)=0b0), respect the timing constraints in Sections 6.4 and 6.5 before reading the FIFO.
- Longer inter-write delays apply, see Section 6 for details

If [PWR\\_CONF.adv\\_power\\_save](#)=0b0 the device is accessible without the restrictions of the advanced power save configuration after 450  $\mu$ s .

---

<sup>6</sup> An effect that causes different signals to become indistinguishable when sampled with low ODR's.

## 4.6. Sensor Data

### Accelerometer Data

The width of acceleration data is 16 bits given in two's complement representation in the registers [DATA\\_8](#) to [DATA\\_13](#). The 16 bits for each axis are split into an MSB upper part and an LSB lower part. Reading the acceleration data registers shall always start with the LSB part. In order to ensure the integrity of the acceleration data, the content of an MSB register is locked by reading the corresponding LSB register (shadowing procedure).

### Accelerometer Filter Settings

The accelerometer digital filter is configured through the Register [ACC\\_CONF](#).

### Accelerometer Filter Modes

The accelerometer filter modes influence the low pass filter characteristics, in particular the 3dB cutoff frequency, noise, and group delay. The accelerometer filter mode is configured through [ACC\\_CONF.acc\\_bwp](#). This datasheet describes the device in normal filter mode configuration for [ACC\\_CONF.acc\\_bwp](#)=0x02.

### Accelerometer Data Processing in Normal and Performance Mode

The data processing for this mode is configured using [ACC\\_CONF.acc\\_filter\\_perf](#)=0b1. In this power mode, the accelerometer data is sampled at equidistant points in the time, defined by the accelerometer output data rate parameter [ACC\\_CONF.acc\\_odr](#). The output data rate can be configured in one of eight different valid ODR configurations going from 12.5 Hz up to 1600Hz.

The characteristics of the implemented low pass filter are described in the following 2 tables:

Table 7: Cutoff freq. of the accelerometer according to ODR, Normal & Performance Mode

Accelerometer ODR [Hz]	12.5	25	50	100	200	400	800	1600
<b>3dB Cutoff frequency [Hz]</b> normal filter mode <a href="#">ACC_CONF.acc_bwp</a> =0x02	5.5	11	22	44	89	178	343	740

Table 8: Accelerometer noise according to ODR, Normal & Performance Mode, +/- 8g range

ODR in Hz	12.5	25	50	100	200	400	800	1600
<b>RMS-Noise (typ.) [mg]</b> normal filter mode <a href="#">ACC_CONF.acc_bwp</a> =0x02	0.38	0.53	0.75	1.06	1.51	2.13	2.96	4.35

Table 9: Accelerometer group delay according to ODR, Normal &amp; Performance Mode

ODR in Hz	12.5	25	50	100	200	400	800	1600
Group Delay (typ.) [ms] normal filter mode <a href="#">ACC_CONF.acc_bwp=0x02</a>	80	40	20.5	10.5	5.4	2	1.3	0.6

### Accelerometer Data Processing in Low Power Mode

Low power mode can be enabled by [PWR\\_CONF.adv\\_power\\_save=0b1](#) and [ACC\\_CONF.acc\\_filter\\_perf=0b0](#). In this power mode, the accelerometer regularly changes between an idle phase where no measurement is performed and an active phase, where data is acquired. The period of the duty cycle for changing between active and idle mode will be determined by the output data rate ([ACC\\_CONF.acc\\_odr](#)). In low power mode, the output data rate can be configured in one of 10 different valid ODR configurations going from 0.78Hz up to 400Hz.

The samples acquired during the active phase will be averaged and the result will be the output data. The number of averaged samples can be determined by the parameter [ACC\\_CONF.acc\\_bwp](#) through the following formula:

$$\begin{aligned} \text{averaged samples} &= 2^{(\text{Val}(\text{acc\_bwp}))} \\ \text{skipped samples} &= (1600/\text{ODR}) - \text{averaged samples} \end{aligned}$$

A higher number of averaged samples will result in a lower noise level of the signal. Since the active phase is increased, the power consumption will also rise.

### Accelerometer Data Ready Interrupt

This interrupt fires whenever a new data sample set from accelerometer is available in Registers [DATA 8](#) to [DATA 13](#). This allows a low latency data readout. In non-latched mode, the interrupt are cleared automatically after 1/(6400Hz). If this automatic clearance is unwanted, please use latched mode (see Section 4.9). The flag [INT\\_STATUS 1.acc\\_drdy\\_int](#) is cleared when the register [INT\\_STATUS 1](#) is read. The flag [STATUS.drdy\\_acc](#) is cleared when any of the Registers [DATA 8](#) to [DATA 13](#) is read.

To enable the data ready interrupt please map it on the desired INT pin via [INT\\_MAP\\_DATA](#).

### Gyroscope Data

The width of gyroscope data is 16 bits given in two's complement representation in the registers [DATA 14](#) to [DATA 19](#). The 16 bits for each axis are split into an MSB upper part and an LSB lower part. Reading the gyroscope data registers shall always start with the LSB part. In order to ensure the integrity of the gyroscope data, the content of an MSB register is locked by reading the corresponding LSB register (shadowing procedure).

## Gyroscope Filter Settings

The gyroscope digital filter can be configured through the Register [GYR\\_CONF](#).

## Gyroscope Filter Modes

The gyroscope filter modes influence the low pass filter characteristics, in particular the 3dB cutoff frequency, noise, and group delay. The gyroscope filter mode is configured through [GYR\\_CONF.gyr\\_bwp](#). This datasheet describes the device in normal filter mode configuration for [GYR\\_CONF.gyr\\_bwp=0x02](#).

## Gyroscope Data Post-Processing

For optimal gyroscope CAS performance the following data post-processing step is necessary:

$$\text{Rate}_x = \text{DATA\_15} \ll 8 + \text{DATA\_14} - \text{GYR\_CAS.factor\_zx} * (\text{DATA\_19} \ll 8 + \text{DATA\_18}) / 2^9$$

$$\text{Rate}_y = \text{DATA\_17} \ll 8 + \text{DATA\_16}$$

$$\text{Rate}_z = \text{DATA\_19} \ll 8 + \text{DATA\_18}$$

Note: [GYR\\_CAS.factor\\_zx](#) is a 7-bit two-complement encoded sign value; if you do not use BST's sensor API, please make sure that you implement sign extension.

## Gyroscope Data Processing in Normal and Performance Mode

The data processing for these modes is configured using [GYR\\_CONF.gyr\\_filter\\_perf=0b1](#). In these power modes, the gyroscope data is sampled at equidistant points in the time, defined by the gyroscope output data rate parameter [GYR\\_CONF.gyr\\_odr](#). The output data rate can be configured in one of eight different valid ODR configurations going from 25 Hz up to 3.2 kHz. For 6.4 kHz operation use FIFO data readout described in section 4.7.

The characteristics of the implemented low pass filter are described in the following tables:

Table 10: Cutoff frequency of the gyroscope according to ODR, Normal & Performance Mode

Gyroscope ODR [Hz]	25	50	100	200	400	800	1.6 k	3.2 k	6.4 k
<b>3dB Cutoff frequency [Hz]</b> normal filter mode <a href="#">GYR_CONF.gyr_bwp=0x02</a>	11	20	39	77	152	300	557	751	712

Table 11: Gyroscope noise according to ODR, Normal Mode, +/- 2000 dps range

ODR in Hz	25	50	100	200	400	800	1.6 k	3.2 k	6.4 k
<b>RMS-Noise (typ.) [mdps]</b> normal filter mode <a href="#">GYR_CONF.gyr_bwp=0x02</a>	31.0	43.9	62.0	87.7	124	176	248	431	500

Table 12: Gyroscope noise according to ODR, Performance Mode, +/- 2000 dps range

ODR in Hz	25	50	100	200	400	800	1.6 k	3.2 k	6.4 k
<b>RMS-Noise (typ.) [mdps]</b> normal filter mode <a href="#">GYR_CONF.gyr_bwp=0x02</a>	21.7	30.7	43.4	61.4	86.9	123	174	302	350

Table 13: Gyroscope group delay according to ODR, Normal and Performance Modes

ODR in Hz	25	50	100	200	400	800	1.6 k	3.2 k	6.4 k
<b>Group Delay (typ.) [ms]</b> normal filter mode <a href="#">GYR_CONF.gyr_bwp=0x02</a>	40	20.5	10.8	5.97	3.55	2.34	0.97	0.82	0.68

### Gyroscope Data Processing in Low Power Mode

Low power mode can be enabled by [PWR\\_CONF.adv\\_power\\_save=0b1](#) and [GYR\\_CONF.gyr\\_filter\\_perf=0b0](#). In this power mode, the gyroscope regularly changes between an idle phase where no measurement is performed and an active phase, where data is acquired. The period of the duty cycle for changing between active and idle mode will be determined by the output data rate ([GYR\\_CONF.gyr\\_odr](#)). The output data rate can be configured in one of 3 different valid ODR configurations 25Hz, 50Hz, and 100Hz. Four samples are acquired during the active phase and will be averaged and the result will be the output data.

### Gyroscope Data Ready Interrupt

This interrupt fires whenever a new data sample set from the gyroscope is available in Registers [DATA 14](#) to [DATA 19](#). This allows a low latency data readout. In non-latched mode, the interrupt are cleared automatically after 1/(6400Hz). If this automatic clearance is unwanted, please use latched mode (see Section 4.9). The flag [INT\\_STATUS\\_1.gyr\\_drdy\\_int](#) is cleared when the register [INT\\_STATUS\\_1](#) is read. The flag [STATUS.drdy\\_gyr](#) is cleared when any of the Registers [DATA 14](#) to [DATA 19](#) is read.

To enable the data ready interrupt please map it on the desired INT pin via [INT\\_MAP\\_DATA](#).

## Temperature Sensor

The temperature sensor has 16 bits defined as:

Value	Temperature
0x7FFF	$87 - 1/2^9$ °C
...	...
0x0000	23 °C
...	...
0x8001	$-(41 - 1/2^9)$ °C
0x8000	Invalid

The measured temperature is accessible via the Registers [TEMPERATURE\\_0](#) and [TEMPERATURE\\_1](#). After enabling the temperature sensor, the register contains the invalid value 0x8000 until the first temperature measurement is completed.

If the gyroscope is enabled (i.e. [PWR\\_CTRL.gyr\\_en](#)=0b01) the temperature sensor is automatically enabled at an update rate of 100 Hz +/-12%.

If the gyroscope is disabled (i.e. [PWR\\_CTRL.gyr\\_en](#)=0b00, e.g. for accelerometer only operation) the temperature sensor must be manually enabled or disabled using [PWR\\_CTRL.temp\\_en](#). Disabling the temperature sensor reduces the overall current consumption of the device by approximately 1.8 µA in average. If the temperature sensor is enabled it updates the results aligned with bit 7 of the Register [SENSORTIME\\_1](#) at an update rate of 0.78 Hz.

If the gyroscope is enabled and [PWR\\_CONF.adv\\_power\\_save](#)=0b0 and [PWR\\_CTRL.gyr\\_en](#)=0b1, the temperature in Registers [TEMPERATURE\\_0](#) and [TEMPERATURE\\_1](#) is updated every 10 ms (+-12%), if the gyroscope is in standby mode or fast-power up mode, the temperature is updated every 1.28 s aligned with bit 15 of the Register [SENSORTIME\\_1](#).

## Sensor Time

The device supports the concept of sensortime. Its core element is a free running counter with a width of 24 bits. It increments with a resolution of 39.0625us. The user can access the current state of the counter by reading registers [SENSORTIME\\_0](#) to [SENSORTIME\\_2](#).

All sensor events e.g. updates of data registers are synchronous to this sensor time register as defined in the table below. With every update of the data register or the FIFO, a bit  $m$  in the registers [SENSORTIME\\_0](#) to [SENSORTIME\\_2](#) toggles where  $m$  depends on the output data rate for the data register and the output data rate and the FIFO downsampling rate for the FIFO. The table below shows which bit toggles for which update rate of data register and FIFO

Bit $m$ in sensor_time	23	22	21	20	19	18	17	16
Resolution [s]	327.68	163.84	81.92	40.96	20.48	10.24	5.12	2.56
Update rate [Hz]	0.0031	0.0061	0.012	0.024	0.049	0.10	0.20	0.39

Bit $m$ in sensor_time	15	14	13	12	11	10	9	8
Resolution [ms]	1280	640	320	160	80	40	20	10
Update rate [Hz]	0.78	1.56	3.125	6.25	12.5	25	50	100

Bit $m$ in sensor_time	7	6	5	4	3	2	1	0
Resolution [ms]	5	2.5	1.250	0.625	0.3125	0.156	0.078	0.039
Update rate [Hz]	200	400	800	1600	3200			

The sensortime is synchronized with the data capturing in the data register and the FIFO. The sensortime supports multiple seconds of sample counting and a sub-microsecond resolution, see Register [SENSORTIME\\_0](#) for details.

Burst reads on the registers [SENSORTIME\\_0](#) to [SENSORTIME\\_2](#) always deliver consistent values, i.e. the value of the register does not change during the burst read.

### Configuration Changes

If device configuration settings in registers [ACC\\_CONF](#), [ACC\\_RANGE](#), [GYR\\_CONF](#), [GYR\\_RANGE](#), or [AUX\\_CONF](#) are changed while the sensors are enabled (accelerometer [PWR\\_CTRL.acc\\_en](#) = 0b1, gyroscope [PWR\\_CTRL.gyr\\_en](#) or auxiliary sensor [PWR\\_CTRL.aux\\_en](#) = 0b1), the configuration changes are not immediately applied. The configuration changes become effective if a sampling event for the currently active ODR coincides with a sampling event for the newly requested ODR on the sensortime sampling grid. In the case where the currently active ODR equals the newly requested ODR, the configuration changes become effective at the next sampling event. See also following figure

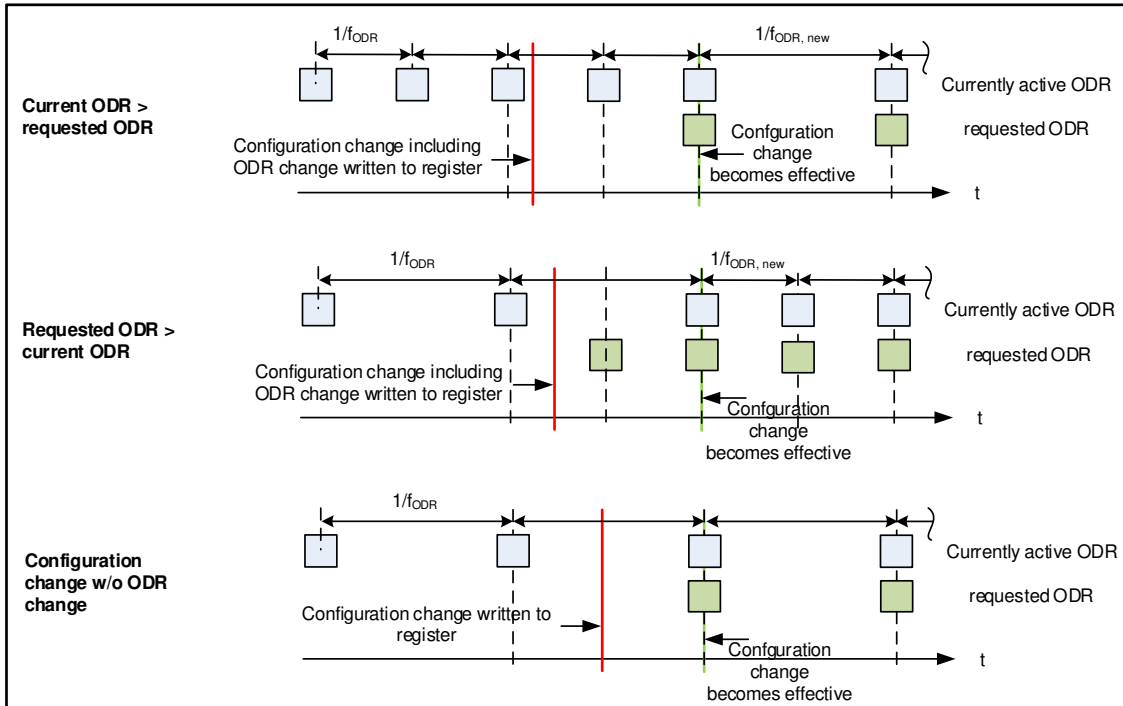



## 4.7. FIFO

The device supports the following FIFO operating modes:

- Streaming mode: overwrites oldest data on FIFO full condition
- FIFO mode: discards newest data on FIFO full condition

The FIFO size is 2048 byte and supports the following interrupts:

- FIFO full interrupt
- FIFO watermark interrupt

FIFO is enabled for accelerometer data with [FIFO CONFIG 1.fifo\\_acc\\_en=0b1](#), for gyroscope data with [FIFO CONFIG 1.fifo\\_gyr\\_en=0b1](#), and auxiliary interface (e.g. magnetometer) data with [FIFO CONFIG 1.fifo\\_aux\\_en=0b1](#) (0b0=disabled).

The FIFO may be used in all power modes of the device to record data. For readout conditions, see following subsection “FIFO in Low Power Mode”.

## Frames

The FIFO captures data in frames, which consist in header mode of a header and a payload data, in headerless mode only payload is stored.

In header mode (standard configuration) each regular frame consists of a one byte header describing properties of the frame (e.g. which sensors are included in this frame) and the payload data itself. Beside the regular frames, which contain the sensor data, there are control frames, which contain metadata (e.g. sensortime).

An overview of the possible frame types is show below

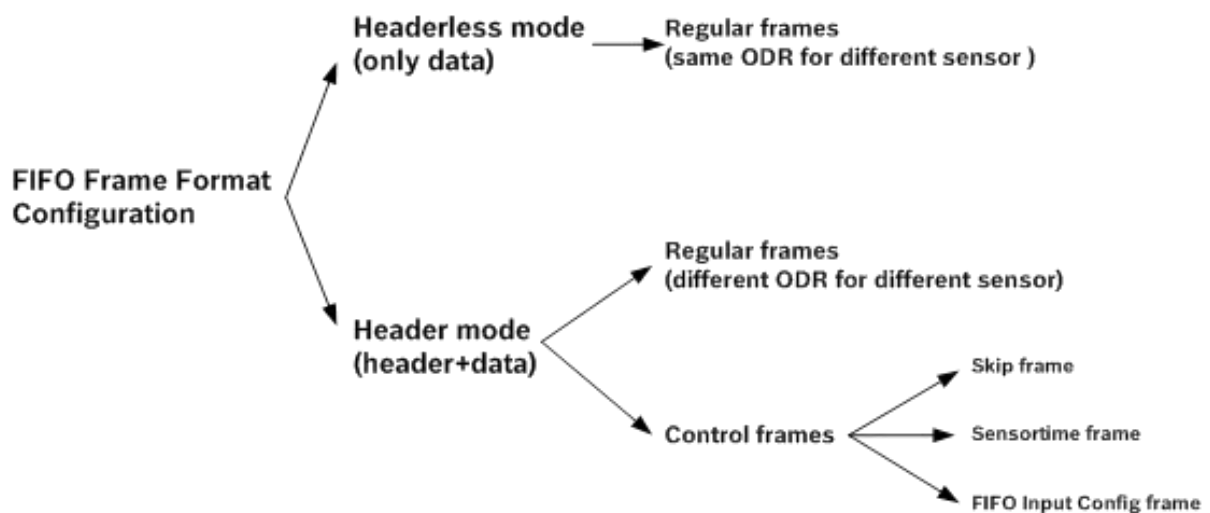

### Header mode

The header has a fixed length of 8 bit and the following format:

Bit	7	6	5	4	3	2	1	0
Content	fh_mode<1:0>		fh_parm<3:0>			fh_ext<1:0>		

These *fh\_mode* and *fh\_parm* and *fh\_ext* fields are defined below

fh_mode<1:0>	Definition	fh_parm <3:0>	fh_ext<1:0>
0b10	Regular frame	Enabled sensors	Tag of INT2 and INT1
0b01	Control frame	Control opcode	
0b00 and 0b11	Reserved	N/A	

fh\_parm=0b0000 is invalid for regular mode, a header of 0x80 indicates an uninitialized frame, which is reported if the fifo read operations reads more data, than contained in the fifo. An uninitialized frame contains one byte of payload 0x00.

In a regular frame, fh\_parm parameter defines which sensors are included in the data part of the frame. The format is

Name	fh_parm<3:0>			
Bit	3	2	1	0
Content	Reserved	FIFO_aux_data	FIFO_gyr_data	FIFO_acc_data

When FIFO\_<sensor x>\_data is 0b1 (0b0) data for sensor x is included (not included) in the data part of the frame.

The fh\_ext<1:0> field are used for external tagging.

The order of the data in the FIFO data frame (see following table) differs from the order defined for the Registers [DATA\\_0](#) to [DATA\\_19](#).

A valid regular frame, contains data of at least one sensor (accelerometer, gyroscope, or auxillary sensor). Only valid frames will be written into the FIFO. E.g. fh\_parm=0b0111 in the header of a frame will result in the data layout shown below.

DATA[X]	Acronym	
X=0	AUX_0	copy of register Val( <a href="#">AUX_RD_ADDR</a> ) in auxiliary sensor register map
X=1	AUX_1	copy of register Val( <a href="#">AUX_RD_ADDR</a> )+1 in auxiliary sensor register map
X=2	AUX_2	copy of register Val( <a href="#">AUX_RD_ADDR</a> )+2 in auxiliary sensor register map
X=3	AUX_3	copy of register Val( <a href="#">AUX_RD_ADDR</a> )+3 in auxiliary sensor register map
X=4	AUX_4	copy of register Val( <a href="#">AUX_RD_ADDR</a> )+4 in auxiliary sensor register map
X=5	AUX_5	copy of register Val( <a href="#">AUX_RD_ADDR</a> )+5 in auxiliary sensor register map
X=6	AUX_6	copy of register Val( <a href="#">AUX_RD_ADDR</a> )+6 in auxiliary sensor register map
X=7	AUX_7	copy of register Val( <a href="#">AUX_RD_ADDR</a> )+7 in auxiliary sensor register map
X=8	GYR_X<7:0> (LSB)	
X=9	GYR_X<15:8> (MSB)	
X=10	GYR_Y<7:0> (LSB)	
X=11	GYR_Y<15:8> (MSB)	
X=12	GYR_Z<7:0> (LSB)	
X=13	GYR_Z<15:8> (MSB)	
X=14	ACC_X<7:0> (LSB)	
X=15	ACC_X<15:8> (MSB)	
X=16	ACC_Y<7:0> (LSB)	
X=17	ACC_Y<15:8> (MSB)	
X=18	ACC_Z<7:0> (LSB)	
X=19	ACC_Z<15:8> (MSB)	

The length of the auxiliary sensor data block in a FIFO frame depends on the configured burst read length of the auxiliary interface in Register [AUX\\_IF\\_CONF.aux\\_rd\\_burst](#):

If the read burst length for the auxiliary sensor is configured to less than 8 byte, the number of data bytes in the regular FIFO frame is reduced accordingly. I.e. in the above example, the gyro data would start before Byte 8.

## Control frames

Control frames are only supported in header mode. There are a number of control frames defined through the *fh\_parm* field. These are shown in below.

A skip frame indicates the number of skipped frames after a FIFO overrun occurred. A sensortime frame contains the sensortime when the last sampled frame stored in the FIFO is read. A FIFO input config frames indicates a change in sensor configuration which affects the sensor data.

The FIFO fill level is contained in registers [FIFO\\_LENGTH 1.fifo byte counter 13 8](#) and [FIFO\\_LENGTH 0.fifo byte counter 7 0](#). The fifo fill level includes the space needed for the regular and the control frames, with the exception of the sensortime frame.

fh_mode<3:0>	Definition	Number of
0x0	Skip Frame	1 byte payload
0x1	Sensortime Frame	3 bytes payload
0x2	Fifo_Input_Config Frame	4 bytes payload
0x3 – 0x7	Reserved	

### Skip Frame (fh\_parm=0x0):

In the case of FIFO overflows, a skip\_frame is prepended to the FIFO content, when read out next time. The data for the frame consists of one byte and contains the number of skipped frames. When more than 0xFF frames have been skipped, 0xFF is returned. A skip frame is expected always as first frame in a FIFO read burst. A skip frame does not consume memory in the FIFO.

### Sensortime Frame (fh\_parm=0x1):

The data for the sensortime frame is a copy of the Register [SENSORTIME 0](#) to [SENSORTIME 2](#) when the last byte of the last sample frame was read. One sensortime frame is always expected as last frame in the FIFO. A sensortime frame is only sent if the FIFO becomes empty during the burst read. A sensortime frame does not consume memory in the FIFO. Sensortime frames are enabled (disabled) by setting [FIFO\\_CONFIG 0.fifo time en](#) to 0b1 (0b0).

### Fifo\_Input\_Config Frame (fh\_parm=0x2):

Whenever the filter configuration of the FIFO input data sources changes, a FIFO input config frame is inserted into the FIFO, before the configuration change becomes active. E.g. when the bandwidth for the accelerometer filter is changed in Register [ACC\\_CONF](#), a FIFO input config frame is inserted before the first frame with accelerometer data with the new bandwidth configuration. The FIFO input config frame contains four byte of data with the format

Bit	7	6	5	4	3	2	1	0
Byte 0	reserved	reserved	aux_ if_ch	aux_ conf_ch	gyr_ range_ch	gyr_ conf_ch	acc_ range_ch	acc_ conf_ch
Byte 1	Sensortime_0 for next frame (may be drop frame)							
Byte 2	Sensortime_1 for next frame (may be drop frame)							
Byte 3	Sensortime_2 for next frame (may be drop frame)							

aux_if_ch	A write to Register <a href="#">AUX_IF_CONF</a> , <a href="#">AUX_RD_ADDR</a> , or <a href="#">AUX_WR_ADDR</a> becomes active.
aux_conf_ch	A write to Register <a href="#">AUX_CONF</a> becomes active.
gyr_range_ch	A write to Register <a href="#">GYR_RANGE</a> becomes active.
gyr_conf_ch	A write to Register <a href="#">GYR_CONF</a> or gyr_FIFO_filt_data or gyr_FIFO_downsampling in Register <a href="#">FIFO_DOWNS</a> becomes active.
acc_range_ch	A write to Register <a href="#">ACC_RANGE</a> becomes active.
acc_conf_ch	A write to Register <a href="#">ACC_CONF</a> or acc_FIFO_filt_data or acc_FIFO_downsampling in Register <a href="#">FIFO_DOWNS</a> becomes active.

If Byte 0 is 0x00, this indicates that this Fifo\_Input\_Config Frame is written, because the fifo or sensor was enabled.

### Headerless mode

When the data rates of all enabled sensor elements are identical, the FIFO header may be disabled in [FIFO CONFIG 1.fifo header en.](#)

The headerless mode supports only regular frames. To be able to distinguish frames from each other, all frames must have the same size. For this reason, any change in configuration that have an impact to frame size or order of data within a frame will cause an instant flush of FIFO, restarting capturing of data with the new settings.

If the auxiliary sensor interface is enabled, the number of auxiliary sensor bytes in a FIFO frame is always [AUX\\_IF\\_CONF.aux\\_rd\\_burst](#) bytes (see section 4.10). If the burst length is less than 8, the device will pad the values read from the auxiliary sensor. E.g. if [AUX\\_IF\\_CONF.aux\\_rd\\_burst=0b01](#) (2 Bytes), a frame with auxiliary sensor, accelerometer, and gyroscope data will look like

DATA[X]	Acronym	
X=0	AUX_0	copy of register Val( <a href="#">AUX_RD_ADDR.read_addr</a> ) in auxiliary sensor register map
X=1	AUX_1	copy of register Val( <a href="#">AUX_RD_ADDR.read_addr+1</a> ) in auxiliary sensor register map
X=2	Padding byte	Undefined value
X=3	Padding byte	Undefined value
X=4	Padding byte	Undefined value
X=5	Padding byte	Undefined value
X=6	Padding byte	Undefined value
X=7	Padding byte	Undefined value
X=8	GYR_X<7:0> (LSB)	
X=9	GYR_X<15:8> (MSB)	
X=10	GYR_Y<7:0> (LSB)	
X=11	GYR_Y<15:8> (MSB)	
X=12	GYR_Z<7:0> (LSB)	
X=13	GYR_Z<15:8> (MSB)	
X=14	ACC_X<7:0> (LSB)	
X=15	ACC_X<15:8> (MSB)	
X=16	ACC_Y<7:0> (LSB)	
X=17	ACC_Y<15:8> (MSB)	
X=18	ACC_Z<7:0> (LSB)	
X=19	ACC_Z<15:8> (MSB)	

## Conditions and Details

### *FIFO frame reads*

If a frame is fully read through the Register [FIFO\\_DATA](#), it gets deleted from the FIFO of the device. If a frame is only partially read it will be repeated completely with the next access both in headerless and in header mode. In headermode, this includes the header. In the case of a FIFO overflow between the first partial read and the second read attempt, the frame is kept only if [FIFO\\_CONFIG\\_0.fifo\\_stop\\_on\\_full](#) =0b1.

### *FIFO overreads*

When more data are read from the FIFO than it contains valid data, 0x8000 is returned in headerless mode. In header mode 0x80 indicates an invalid frame.

### *Frame rates*

The frame sampling rate of the FIFO is defined by the maximum output data rate of the sensors enabled for FIFO sampling. The FIFO sampling configuration is set in register [FIFO\\_CONFIG\\_0](#) to [FIFO\\_CONFIG\\_1](#). It is possible to select filtered or pre-filtered data as an input to the FIFO. If pre-filtered data is selected in register [FIFO\\_DOWNS.acc\\_fifo\\_filt\\_data](#) for the accelerometer, the sample rate is 1600 Hz. If pre-filtered data is selected in register [FIFO\\_DOWNS.gyr\\_fifo\\_filt\\_data](#) for the gyroscope, the sample rate is 6400 Hz. The range of the pre-filtered gyroscope data is defined by [GYR\\_RANGE.ois\\_range](#) and independent of the range configured for the data register and filtered data in the fifo defined by [GYR\\_RANGE.gyr\\_range](#). The input data rate to the FIFO can be reduced by selecting a down-sampling factor  $2^k$  in registers [FIFO\\_DOWNS.acc\\_fifo\\_downs](#) or [FIFO\\_DOWNS.gyr\\_fifo\\_downs](#) where  $k=\{0..7\}$ .

### *FIFO overflow*

In the case of an overflow the FIFO can either stop recording data or overwrite the oldest data. The behavior is controlled by Register [FIFO\\_CONFIG\\_0.fifo\\_stop\\_on\\_full](#). If [FIFO\\_CONFIG\\_0.fifo\\_stop\\_on\\_full](#) =0b0, the FIFO logic may delete the oldest frames. If header mode is enabled and the free FIFO space falls below the maximum size frame, the skip frame is prepended at the next FIFO readout.

If [FIFO\\_CONFIG\\_0.fifo\\_stop\\_on\\_full](#) =0b1, the newest frame may be discarded, if the free FIFO space falls below the maximum size frame. If header mode is enabled, a skip frame is prepended at the next FIFO readout (which is **not** the position where the frame(s) have been discarded).

During a FIFO read operation of the host, no data at the FIFO tail may be dropped. If the host reads the FIFO with a slower rate than it is filled, it may happen that the sensor needs to drop new data, even when [FIFO\\_CONFIG\\_0.fifo\\_stop\\_on\\_full](#) =0b0. These events are recorded in the Register [ERR\\_REG.fifo\\_err](#).

### FIFO data synchronization

All sensor data are sampled with respect to a common ODR time grid. Even if a different ODR is selected for the acceleration and the auxiliary sensor the data remains synchronized:

If a frame contains a sample from a sensor element with ODR  $x$ , then it must contain also samples of all sensor elements with an ODR  $y \geq x$ . This applies for steady state operation. In transition phases, it is more important not to lose data, therefore exceptions are possible if the sensor elements with ODR  $y > x$  do not have data, e.g. due to a sensor configuration change.

FIFO Data Synchronization Scheme in the following figure illustrates the steady state and transient operating conditions.

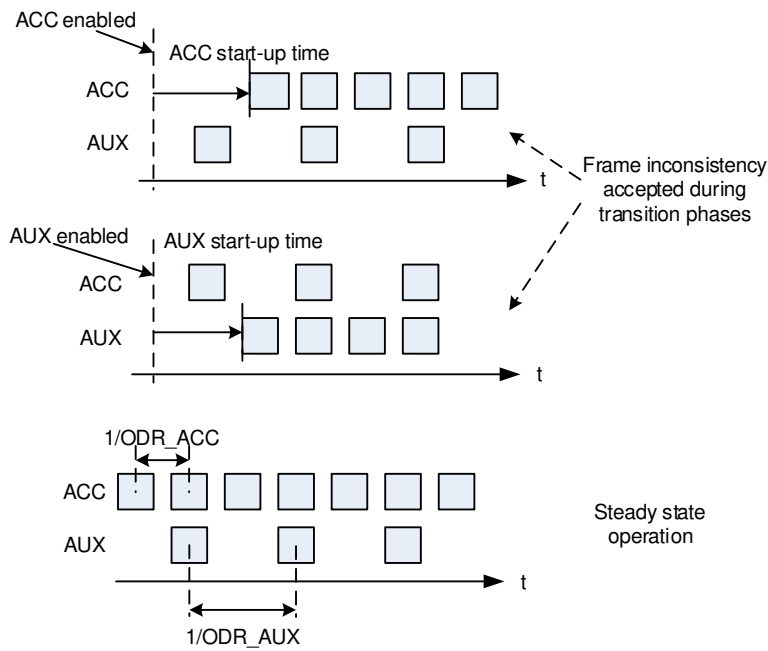



## FIFO synchronization with external interrupts

External interrupts may be synchronized into the FIFO data. For this operation mode the [FIFO CONFIG 1.fifo\\_tag\\_int1\\_en](#) and [FIFO CONFIG 1.fifo\\_tag\\_int2\\_en](#) need to be enabled, as well as [INT1\\_IO\\_CTRL.input\\_en](#) and [INT2\\_IO\\_CTRL.input\\_en](#). The `fh_ext` field in FIFO header will then be set according to the signal at the INT1/INT2 inputs. The minimum active level of the external signal is 10 ns.

## FIFO Interrupts

The FIFO supports two interrupts, a FIFO full interrupt and a watermark interrupt:

- The FIFO full interrupt is issued when the FIFO fill level is above the full threshold. The full threshold is reached just before the last two frames are stored in the FIFO.
- The FIFO watermark is issued when the FIFO fill level is equal or above a watermark defined in Register [FIFO WTM 1.fifo\\_water\\_mark\\_12\\_8](#).

In order to enable/use the FIFO full or watermark interrupts, map them on the desired interrupt pin via [INT\\_MAP\\_DATA](#).

Latched FIFO interrupts will only be cleared, if the status register gets read and the fill level is below the corresponding FIFO interrupt (full or watermark).

## FIFO Reset

The user can trigger a FIFO reset by writing the command `fifo_flush` (0xB0) in [CMD](#). Automatic resets are only performed in the following cases:

- A sensor is enabled or disabled in headerless mode
- A transition between headerless and headermode or vice versa has occurred.
- Size of auxiliary sensor data in a frame changed in header or headerless mode

## FIFO in Low Power Mode

In the low power mode the device supports FIFO usage. The data storage into the FIFO is identical to the normal and performance mode, for the readout the description below applies.

- If [PWR\\_CONF.fifo\\_self\\_wakeup](#)=0b0 the advanced power save configuration needs to be disabled ([PWR\\_CONF.adv\\_power\\_save](#)=0b0) before reading out FIFO data.
- If [PWR\\_CONF.fifo\\_self\\_wakeup](#)=0b1 and the FIFO watermark or FIFO full interrupt is triggered, the restriction for [PWR\\_CONF.adv\\_power\\_save](#)=0b1 (see Section 4.5) do not apply as long as a single burst read on Register [FIFO\\_DATA](#) completes. This may be used to read the complete FIFO with one single burst read without leaving low power mode. Without a FIFO watermark interrupt or full interrupt, the advanced power save configuration needs to be disabled ([PWR\\_CONF.adv\\_power\\_save](#)=0b0) before reading out FIFO data.

## 4.8. Advanced Features

### Global Configuration

The configuration of the interrupt feature engine is described in the Registers [FEATURES](#). These registers are partitioned into several pages, the page valid for the next read or write to the Registers [FEATURES](#) is selected by the Register [FEAT\\_PAGE.page](#). Writes to a [FEATURES](#) register must be 16-bit word oriented, i.e. writes should start at an even address (2m) and the last byte written should be at an odd address (2n+1), where  $0x30 \leq 2m \leq 2n < 0x3F$ . If the write start address is less than 0x30 the write may start at any address (see example 4 below), if the end address is greater than 0x3F, it may stop at any address (see example 5 below).

- For register writes which stop at an even SPI address (2n), the data at the odd SPI address (2n+1) are undefined (see Example 2, 3 below)
- For writes which start at an odd SPI address (2m+1), the data at the even address (2m) are undefined. (see Example 3 below)

Ex. 1) Write 4 bytes starting at address 0x30

0x30	Valid Data
0x31	Valid Data
0x32	Valid Data
0x33	Valid Data

Ex. 2) Write 3 bytes starting at address 0x30

0x30	Valid Data
0x31	Valid Data
0x32	Valid Data
0x33	Undefined

Ex. 3) Write 2 bytes starting at address 0x31

0x30	Undefined
0x31	Valid Data
0x32	Valid Data
0x33	Undefined

Ex. 4) Write 9 bytes starting at address 0x29

0x29	Valid Data
0x2A	Valid Data
⋮	⋮
0x2E	Valid Data
0x2F	Valid Data
0x30	Valid Data
0x31	Valid Data

Ex. 5) Write 5 bytes starting at address 0x3E

0x3E	Valid Data
0x3F	Valid Data
0x40	Valid Data
0x41	Valid Data
0x42	Valid Data
⋮	⋮

Make sure the sensor is initialized properly before the feature configuration is performed (see description in section 4.4.)

Some features generate interrupts. [INT1\\_MAP\\_FEAT](#) and [INT2\\_MAP\\_FEAT](#) configure these features. [INT\\_STATUS\\_0](#) reports the interrupt source.

In order to minimize the power consumption or to enable always-on motion sensing, all advanced features (algorithms) rely on accelerometer data samples.

#### Minimum Bandwidth Settings

If the filter performance of the accelerometer is configured to high performance ([ACC\\_CONF.acc\\_filter\\_perf](#) is 0b1), the features operate at highest performance independent of the ODR and the bandwidth set by the host.

If the filter performance of the accelerometer is configured to low power ([ACC\\_CONF.acc\\_filter\\_perf](#) is 0b0), the feature performance is depending on the ODR and the averaging factor ([ACC\\_CONF.acc\\_bwp](#)) set by the host:

1. For all features, the ODR must be set to minimum 50 Hz

If the device configuration does not meet the minimum requirements, the corresponding flag in the Register [INTERNAL\\_STATUS](#) is set, if one of the advanced features is enabled. In this case the features are still evaluated, the same number of samples are evaluated, but they are sampled at the lower rate.

#### Error Interrupts

The device supports an error interrupt, which triggers if the device cannot be recovered without a soft reset or a POR. This error interrupt is enabled through [INT\\_MAP\\_DATA](#). The interrupt status is available in [INT\\_STATUS\\_1.err\\_int](#). After restarting a device reinitialization must be done.

#### Axis remapping for interrupt features

If the coordinate system of the end device differs from the sensor coordinate system described in Section 8.2 the sensor axis must be remapped to use the orientation dependent features (e.g. orientation interrupt, flat interrupt) properly.

Axis remapping register allows the host to freely map individual axis to the coordinate system of the used platform. Individual axis can be mapped to any other defined axis. The sign value of the axis can be also configured. For example x axis can be mapped to  $-x$  axis,  $+y$  axis,  $-y$  axis,  $+z$  axis or  $-z$  axis. Similarly, other axes also have their own combinations.

Invalid remappings are signaled through the register [INTERNAL\\_STATUS.axes\\_remap\\_error](#) if an advanced feature is enabled.

#### **Note:**

The axis remapping applies only to the data fetched into the features. The [DATA\\_0](#) to [DATA\\_13](#) registers and FIFO are not affected and should be remapped accordingly on the driver level.

#### Configuration settings:

1. [GEN\\_SET\\_1.map\\_x\\_axis](#) – describes which axis shall be mapped to x axis.
2. [GEN\\_SET\\_1.map\\_x\\_axis\\_sign](#) – describes whether the mapped axis shall be inverted or not to be inverted.
3. [GEN\\_SET\\_1.map\\_y\\_axis](#) – describes which axis shall be mapped to y axis.
4. [GEN\\_SET\\_1.map\\_y\\_axis\\_sign](#) – describes whether the mapped axis shall be inverted or not to be inverted.
5. [GEN\\_SET\\_1.map\\_z\\_axis](#) – describes which axis shall be mapped to z axis.
6. [GEN\\_SET\\_1.map\\_z\\_axis\\_sign](#) – describes whether the mapped axis shall be inverted or not to be inverted.

## Anymotion Detection

The anymotion detection uses the slope between two acceleration signals to detect changes in motion. The interrupt is configured by setting enable flag [ANYMO 2.enable](#) along with at least one of the following flags: [ANYMO 1.select x](#), [ANYMO 1.select y](#), and [ANYMO 1.select z](#) respectively for each axis.

It generates an interrupt when the absolute value of the slope (the difference between two accelerations) exceeds the preset [ANYMO 2.threshold](#) for a certain number of consecutive data points [ANYMO 1.duration](#).

The slope (difference) is being computed between the current acceleration sample and the reference sample. The reference sample is updated while the anymotion is detected; basically this means the reference is the last state when sensor detected Anymotion.

The interrupt generated will be reset as soon as the slope value falls below the threshold.

### Configuration settings

1. [ANYMO 2.enable](#) – enable the feature.
2. [ANYMO 1.duration](#) – the number of consecutive data points for which the threshold condition must be respected, for interrupt assertion.
3. [ANYMO 2.threshold](#) – the slope threshold.
4. [ANYMO 1.select x](#) – select the feature for x axis
5. [ANYMO 1.select y](#) – select the feature for y axis
6. [ANYMO 1.select z](#) – select the feature for z axis

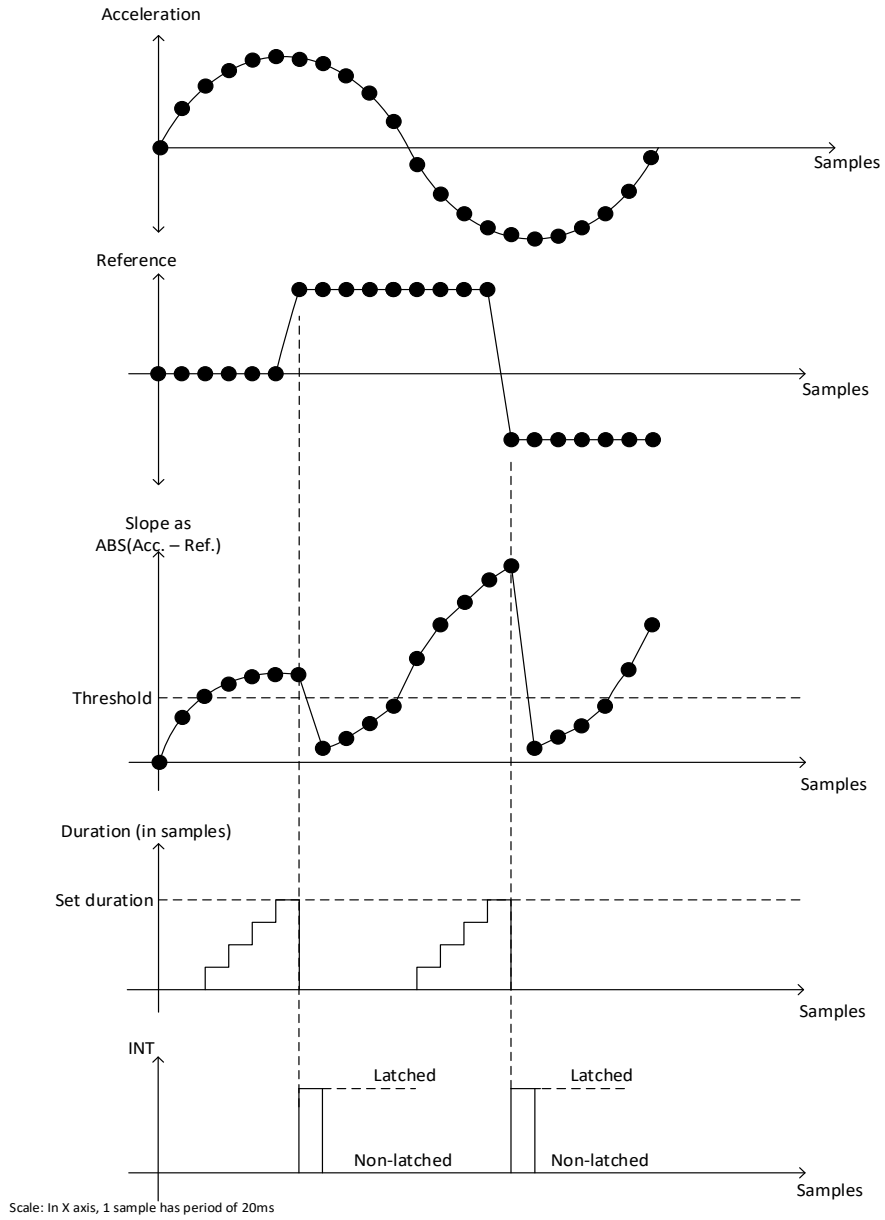

Figure 1: Any-motion detection

## Nomotion Detection

The interrupt is configured by setting enable flag [NOMO 2.enable](#) along with at least one of the following flags: [NOMO 1.select x](#), [NOMO 1.select y](#), and [NOMO 1.select z](#) respectively for each axis.

Nomotion Detection interrupt is generated when the slope on all selected axis remains smaller than a programmable [NOMO 2.threshold](#) for a programmable time. The signals and timings relevant to the nomotion interrupt functionality are depicted in the figure below.

Register [NOMO 1.duration](#) defines the number of consecutive slope data points of the selected axis which must exceed the threshold for an interrupt to be asserted.

### *Configuration settings*

1. [NOMO 2.enable](#) – enable the feature.
2. [NOMO 1.duration](#) – the number of consecutive data points for which the threshold condition must be respected, for interrupt assertion.
3. [NOMO 2.threshold](#) – the slope threshold.
4. [NOMO 1.select x](#) – select the feature for x axis
5. [NOMO 1.select y](#) – select the feature for y axis
6. [NOMO 1.select z](#) – select the feature for z axis

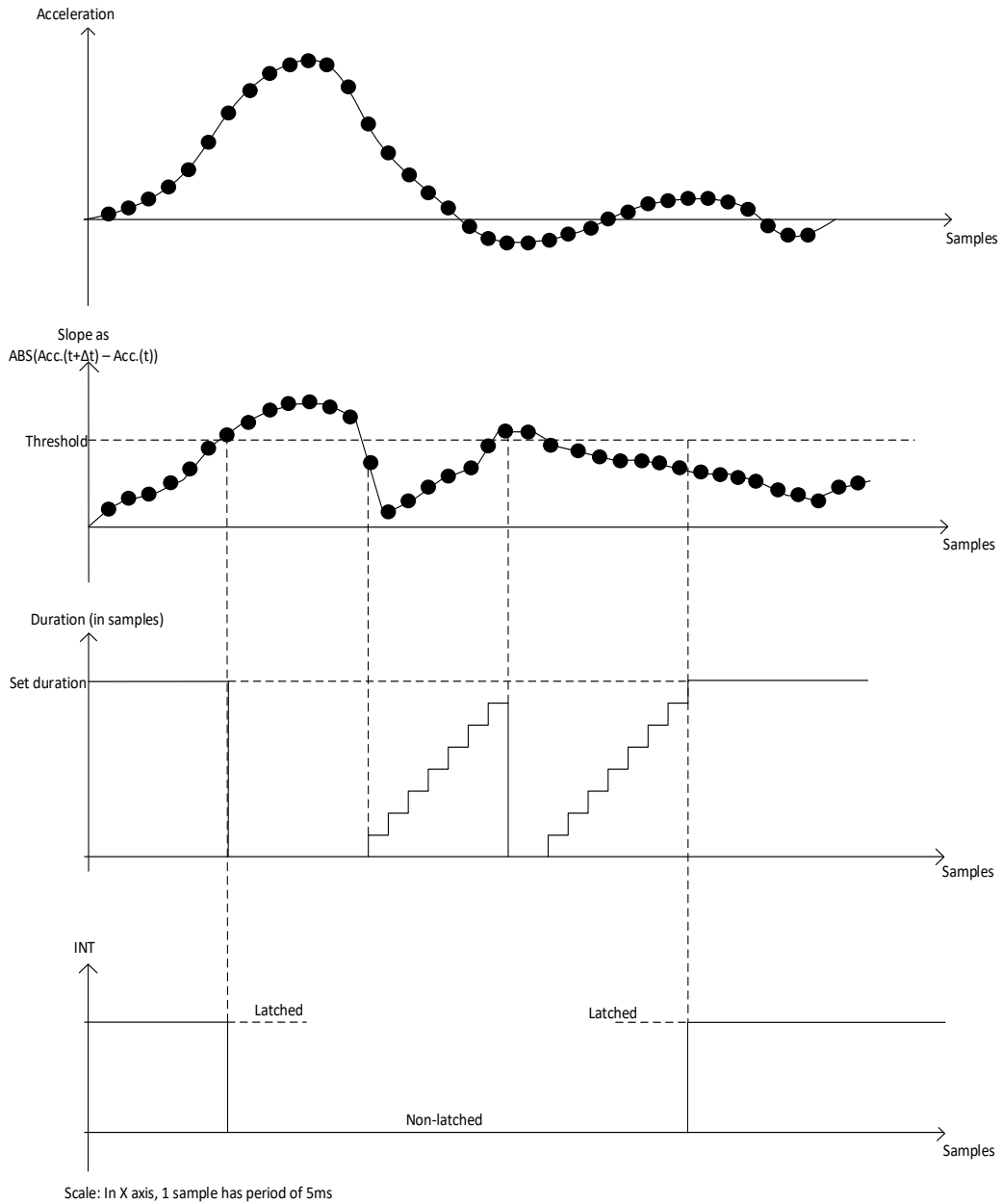

Figure 2: No-motion detection

## Significant Motion Detection

The significant motion interrupt implements the interrupt required for motion detection in Android 4.3 and greater: [https://source.android.com/devices/sensors/sensor-types.html#significant\\_motion](https://source.android.com/devices/sensors/sensor-types.html#significant_motion).

A significant motion is a motion due to a change in the user location.

Examples of such significant motions are walking or biking, sitting in a moving car, coach or train, etc. Examples of situations that does typically not trigger significant motion include phone in pocket and person is stationary or phone is at rest on a table which is in normal office use.

### Configuration settings

1. [SIGMO 2.enable](#) – indicates if this feature is enabled or not.
2. [SIGMO 1.block\\_size](#) – Defines the duration after which the significant motion interrupt is triggered. It is expressed in 50 Hz samples (20 ms). Default value is 0xFA=5sec.

## Activity and Activity Change Recognition

The device can detect simple user activities (unknown, still, walking, running) and can send an interrupt if those are changed, e.g. from walking to running or vice versus. The interrupt is shared with step detector/step counter watermark interrupts and can be configured independently of all other interrupts to any of the interrupt lines.

1. The device reports changes for following activity changes by an interrupt
  1. Still - 0
  2. Walking - 1
  3. Running -2
  4. Unknown – 3
2. Activity interrupt will be triggered only when there is change in status
3. [ACT\\_OUT.act\\_out](#) reports the activity status

During power on, activity will be unknown (0x03) and the device receives an activity change interrupt once activity is enabled, and a new activity detected. When activity is disabled, status will be changed to unknown.

### Configuration settings

[SC 26.en\\_activity](#) indicates if the activity feature is enabled or not



## Wrist Wear Wakeup

Wrist wear wakeup feature is designed to detect any natural way of user moving the hand to see the watch dial when wearing a classical wrist watch. The feature is intended to be used as wakeup gesture (i.e. for triggering screen-on or screen-off) in wrist wearable devices.

This feature has dependency on the device orientation in the user system. Implementation of the feature to detect gesture assumes that the sensor co-ordinate frame is aligned with the device/system co-ordinate frame. The assumed default device/system co-ordinate frame is depicted below. Please refer to section regarding axis remapping

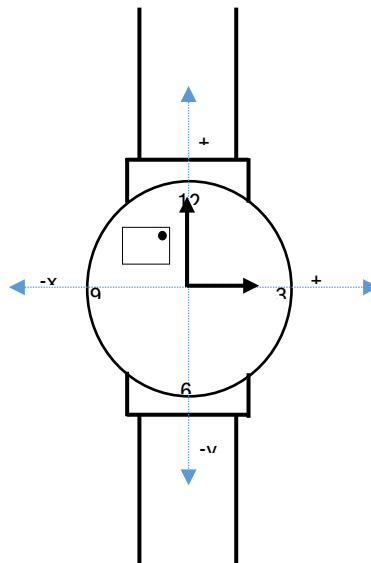

Figure 3: Device co-ordinate system assumed for gesture detection

The feature can distinguish if the device is in one of the following two positions:

- Focus position: In this position, the arm in-front of the body and the user should be able to comfortably look at the watch dial.
- Non-focus position: In this position, the user is not able to look at the watch dial.

[WR\\_WAKEUP\\_3.min\\_angle\\_nonfocus](#) and [WR\\_WAKEUP\\_2.min\\_angle\\_focus](#) can be used to adjust the angle change needed to detect a wrist wear wakeup gesture. [WR\\_WAKEUP\\_4.max\\_tilt\\_lr](#), [WR\\_WAKEUP\\_5.max\\_tilt\\_ll](#), [WR\\_WAKEUP\\_6.max\\_tilt\\_pd](#) and [WR\\_WAKEUP\\_7.max\\_tilt\\_pu](#) can be used to define the maximum tilt angle within which device will still remain in focus position.

Table 14: Positive use-case scenarios for the wrist wear wakeup gestures

Environment	Scenario	Device initial position	User movement
Outdoor / Indoor / train / bus	Walking	Arm swinging / hand in pocket	Lifts and brings the arm in-front of the body to be able to comfortably look at the watch dial
Outdoor / Indoor	Walking / Running / Jogging	Arm swinging	Lift and bring the arm in-front of the body to be able to comfortably look at the watch dial
Outdoor / Indoor / train / bus	Sitting / Standing	Arm is down on side of the body / hand in pocket	Lifts and brings the arm in-front of the body to be able to comfortably look at the watch dial
		Arm is in-front of the body	Rolls the wrist towards the user to look at the watch dial
Indoor / train	Working with computer	Arm on table or arm rest	Rolls the wrist towards the user to look at the watch dial

#### Configuration Settings

- [WR\\_WAKEUP\\_1.enable](#) - Enables the feature.
- [WR\\_WAKEUP\\_2.min\\_angle\\_focus](#) – Cosine of minimum expected attitude change of the device within 1 second time window when moving within focus position.
- [WR\\_WAKEUP\\_3.min\\_angle\\_nonfocus](#) – Cosine of minimum expected attitude change of the device within 1 second time window when moving from non-focus to focus position.
- [WR\\_WAKEUP\\_4.max\\_tilt\\_lr](#) – Sine of the maximum allowed downward tilt angle in landscape right direction of the device, when it is in focus position (i.e. user is able to comfortably look at the dial of wear device).
- [WR\\_WAKEUP\\_5.max\\_tilt\\_ll](#) – Sine of the maximum allowed downward tilt angle in landscape left direction of the device, when it is in focus position (i.e. user is able to comfortably look at the dial of wear device).
- [WR\\_WAKEUP\\_6.max\\_tilt\\_pd](#) – Sine of the maximum allowed backward tilt angle in portrait down direction of the device, when it is in focus position (i.e. user is able to comfortably look at the dial of wear device).
- [WR\\_WAKEUP\\_7.max\\_tilt\\_pu](#) – Sine of the maximum allowed forward tilt angle in portrait up direction of the device, when it is in focus position (i.e. user is able to comfortably look at the dial of wear device).

## Wrist Wear Navigation Gesture Detector

BMI270 is designed for Wear OS by Google™<sup>7</sup> and features wrist gestures such as flick in/out, push arm down/pivot up, wrist jiggle/shake that help navigate the smartwatch.

See <https://support.google.com/wearos/answer/6312406?hl=en>

### Flick in/out

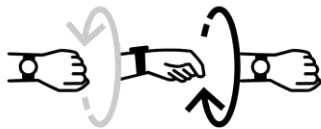

Flick-in movement



Flick-out movement

Figure 4: Flick-in/out movement

For flick-in detection, the user must slowly turn the wrist away from the body (i.e. roll-out shown with a light-grey arrow in) and then quickly bring it back (i.e. roll-in shown with a darker-black arrow in to its original position).

For flick-out detection, the user must quickly turn the wrist away from the body (i.e. roll-out shown with a darker-black arrow in above picture) and then slowly bring it back (i.e. roll-in shown with a light-grey arrow in above picture) to its original position.

The speed of the roll-out and roll-in movements determine if the user performed a flick-in or a flick-out movement. [WR\\_GEST\\_3.min\\_flick\\_samples](#) can be used to control the time difference between the roll-in and roll-out movement. [WR\\_GEST\\_2.min\\_flick\\_peak](#) can be used to adjust the amount to tilt needed on the device to detect a flick gesture.

---

<sup>7</sup> Wear OS by Google is a trademark of Google LLC

### Push arm down/Pivot up

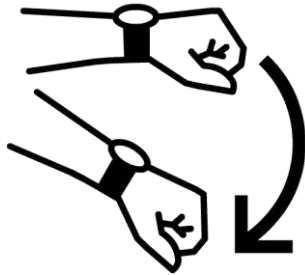

Push-arm-down movement

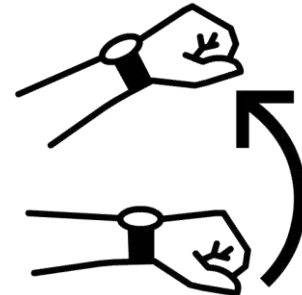

Pivot-up movement

Figure 5: Push arm-down/pivot up

For push-arm down detection, the user should hold the arm in front of the body and quickly push down and then bring it back normally to the original position.

For pivot-up detection, the user should hold the arm in front of the body and quickly pivot up and then bring it back normally to the original position.

### Wrist Jiggle / Shake

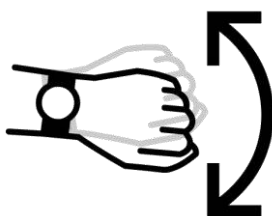

Shake or jiggle movement

Figure 6: Wrist Jiggle

For a jiggle detection, the user must shake the hand quickly.

The device will detect the above mentioned gestures only when the user completes the movement within the duration defined by [WR\\_GEST\\_4.max\\_duration](#).

Once feature is disabled, output will hold the previous value. This feature has dependency on the device orientation in the user system. Please refer to section about axis remapping.

## Configuration settings

- [WR\\_GEST\\_1.enable](#) - Enables the feature.
- [WR\\_GEST\\_1.wearable\\_arm](#) – Configures the device in left (0) or right (1) arm. By default, the wearable device is assumed to be in left arm i.e. default value is 0."
- [WR\\_GEST\\_2.min\\_flick\\_peak](#) – Sine of the minimum tilt angle in portrait down direction of the device when wrist is rolled away (roll-out) from user.
- [WR\\_GEST\\_3.min\\_flick\\_samples](#) – Value of minimum time difference between wrist's roll-out and roll-in movement during flick gesture.
- [WR\\_GEST\\_4.max\\_duration](#) – Maximum time within which gesture movement has to be completed.

## Output details

- [WR\\_GEST\\_OUT.wr\\_gest\\_out](#) – 3-bits indicate type of gestures detected:

Gestures	Value
No gesture	0
Push arm down	1
Pivot up	2
Wrist shake/jiggle	3
Flick in	4
Flick out	5

## Step counter / detector (Wrist-worn)

The wrist worn step counter/detector in BMI270 is optimized for wearable applications including smartwatches/bands/fitness trackers, among others. The stepcounter algorithm is optimized for high accuracy in wrist use-case applications, while Step Detector is optimized for low latency.

Table 15: Step counter Configuration

Configuration	
Parameters	Wrist
<a href="#">SC 1.param 1</a>	301
<a href="#">SC 2.param 2</a>	31700
<a href="#">SC 3.param 3</a>	315
<a href="#">SC 4.param 4</a>	31451
<a href="#">SC 5.param 5</a> (STEP_BUFFER_SIZE)	4
<a href="#">SC 6.param 6</a>	31551
<a href="#">SC 7.param 7</a>	27853
<a href="#">SC 8.param 8</a>	1219
<a href="#">SC 9.param 9</a>	2437
<a href="#">SC 10.param 10</a>	1219
<a href="#">SC 11.param 11</a>	-6420
<a href="#">SC 12.param 12</a>	17932
<a href="#">SC 13.param 13</a>	1
<a href="#">SC 14.param 14</a>	39
<a href="#">SC 15.param 15</a>	25
<a href="#">SC 16.param 16</a>	150
<a href="#">SC 17.param 17</a>	160
<a href="#">SC 18.param 18</a>	1
<a href="#">SC 19.param 19</a>	12
<a href="#">SC 20.param 20</a>	15600
<a href="#">SC 21.param 21</a>	256
<a href="#">SC 22.param 22</a>	1
<a href="#">SC 23.param 23</a>	3
<a href="#">SC 24.param 24</a>	1
<a href="#">SC 25.param 25</a>	14

1. [SC 26.watermark level](#) – watermark level; the step counter will trigger output every time specific number of steps are counted
2. [SC 26.reset counter](#) – flag to reset the counted steps. Step count value can be reset only when any one of features mentioned in this register is enabled.
3. [SC 26.en counter](#) – indicates if the Step Counter feature is enabled or not.
4. [SC 26.en detector](#) – indicates if the Step Detector feature is enabled or not.
5. [SC 26.en activity](#) – indicates if the activity feature is enabled or not
6. [SC 1.param 1](#) to [SC 25.param 25](#) – there are 25 parameters, which can customize the sensitivity of the Step Counter and Detector.

## 4.9. General Interrupt Pin Configuration

### Electrical Interrupt Pin Behavior

Both interrupt pins PIN1 and PIN2 can be configured to show the desired electrical behavior. Interrupt pins can be enabled in [INT1\\_IO\\_CTRL.output\\_en](#) respectively [INT2\\_IO\\_CTRL.output\\_en](#). The characteristic of the output driver of the interrupt pins may be configured with bits [INT1\\_IO\\_CTRL.od](#) and [INT2\\_IO\\_CTRL.od](#). By setting these bits to 0b1, the output driver shows open-drive characteristic, by setting the configuration bits to 0b0, the output driver shows push-pull characteristic.

The electrical behavior of the Interrupt pins, whenever an interrupt is triggered, can be configured as either “active-high” or “active-low” via [INT1\\_IO\\_CTRL.lv](#) respectively [INT2\\_IO\\_CTRL.lv](#).

Both interrupt pins can be configured as input pins via [INT1\\_IO\\_CTRL.input\\_en](#) respectively [INT2\\_IO\\_CTRL.input\\_en](#). This is necessary when FIFO tag feature is used (see Section 4.7 “FIFO synchronization with external interrupts”). If both are enabled, the input (e.g. marking FIFO) is driven by the interrupt output.

The device supports edge and level triggered interrupt inputs, this can be configured through [FIFO\\_CONFIG1.fifo\\_tag\\_int1\\_en](#) and [FIFO\\_CONFIG1.fifo\\_tag\\_int2\\_en](#).

The device supports non-latched and latched interrupts modes for data ready, FIFO watermark, FIFO full, error, and the advanced feature interrupts. The mode is selected by [INT\\_LATCH.int\\_latch](#). Non-latched interrupts are designed for systems using edge triggered interrupts, latched interrupts are designed for systems using level-triggered interrupts.

In latched mode an asserted interrupt status in [INT\\_STATUS\\_0](#) (advanced feature interrupts) or [INT\\_STATUS\\_1](#) (data ready, FIFO and error interrupts) and the selected pin are reset if the corresponding status register is read. If the interrupt activation condition still holds when the interrupt is reset, the interrupt status and pin are asserted again. If more than one interrupt pin is used in latched mode, all interrupts in [INT\\_STATUS\\_0](#) should be mapped to one interrupt pin and all interrupts in [INT\\_STATUS\\_1](#) should be mapped to the other interrupt pin. If just one interrupt pin is used all interrupts may be mapped to this interrupt pin.

In the non-latched mode the selected pin are reset as soon as the activation condition is not valid anymore. The interrupt status bits are active until read by the host.

### Interrupt Pin Mapping

The data ready, FIFO watermark, FIFO full, error, and the advanced feature interrupts are mapped to the external INT1 or INT2 pins by setting the corresponding bits in the Registers [INT\\_MAP\\_DATA](#), [INT1\\_MAP\\_FEAT](#) and [INT2\\_MAP\\_FEAT](#). To unmap these interrupts, the corresponding bits must be reset.

Once an interrupt triggered the output pin, the host can derive the source of the interrupt of the corresponding status bit in the Register: [INT\\_STATUS\\_0](#) and [INT\\_STATUS\\_1](#).

#### 4.10. Auxiliary Sensor Interface

The auxiliary interface allows to attach one auxiliary sensor (AUX, e.g. magnetometer) on the secondary interface of the device as shown in the figure below.

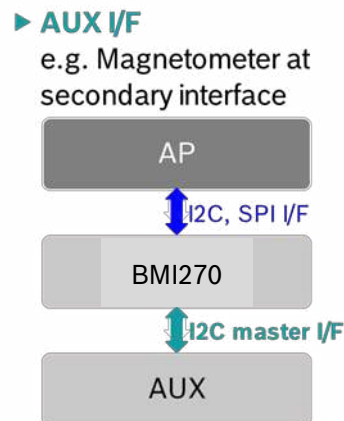

Figure 7: 9-DOF Solution w/ magnetometer (AUX) connected to the 2<sup>nd</sup> I/F

#### Structure and Concept

The device controls the data acquisition of the auxiliary sensor and presents the data to the application processor through the primary I2C or SPI interface. No other I2C master or slave devices must be attached to the auxiliary sensor interface.

The device autonomously reads the sensor data from a compatible auxiliary sensor without intervention of the application processor and stores the data in its data registers and FIFO. The initial setup of the auxiliary sensor after power-on is done through indirect addressing.

The main benefits of the auxiliary sensor interface are

- Synchronization of sensor data of auxiliary sensor and accelerometer. This results in an improved sensor data fusion quality.
- Usage of the device FIFO for auxiliary sensor data (BMM150 does not have a FIFO). This is important for monitoring applications.



## Interface Control

The auxiliary sensor functionality is supported only if an AUX sensor is connected according to Section 7.3 and the auxiliary interface is configured for the auxiliary sensor operation by [PWR\\_CTRL.aux\\_en=0b1](#). If the auxiliary interface is not used for auxiliary sensor operation, then the auxiliary sensor interface must remain disabled by setting [PWR\\_CTRL.aux\\_en=0b0](#) (default).

To change the power mode of the auxiliary sensor, both the power mode of the auxiliary interface and the auxiliary sensor part needs to be changed, e.g. to set the auxiliary sensor to suspend mode:

- The auxiliary sensor part itself must be put into suspend mode by writing the respective configuration bits of the auxiliary sensor part. The power mode of the auxiliary sensor part is controlled by setting the device auxiliary sensor interface into manual mode by [AUX\\_IF\\_CONF.aux\\_manual\\_en=0b1](#) and then communicating with the auxiliary sensor part through the device registers [AUX\\_RD\\_ADDR](#), [AUX\\_WR\\_ADDR](#), and [AUX\\_WR\\_DATA](#). For details see Section 4.10
- Set the auxiliary sensor interface to suspend in Register [PWR\\_CTRL.aux\\_en=0b0](#). Changing the auxiliary sensor interface power mode to suspend does not imply any mode change in the auxiliary sensor.

## Interface Configuration

The configuration registers that control the auxiliary sensor interface operation, are only affecting the interface to the auxiliary sensor, not the configuration of the sensor itself (this must be done in setup mode).

There are three basis configurations of the auxiliary sensor interface:

- No auxiliary sensor access
- Setup mode: Auxiliary sensor access in manual mode
- Data mode: Auxiliary sensor access through hardware readout loop.

The setup of the auxiliary sensor itself must be done through the primary interface using indirect addressing in setup mode. When collecting sensor data, the device autonomously triggers the measurement of the auxiliary sensor using the auxiliary sensor forced mode and the data readout from the auxiliary sensor (data mode).

In setup mode, the auxiliary sensor may be configured and trim data may be read out from the auxiliary sensor. In the data mode the auxiliary sensor data are continuously copied into the device's registers and may be read out from the device directly over the primary interface. For a BMM150 magnetometer, these are the auxiliary sensor data itself and Hall resistance, temperature is not required. The table below shows how to configure these three modes using the registers [PWR\\_CONF](#), [PWR\\_CTRL](#), and [AUX\\_IF\\_CONF.aux\\_manual\\_en](#).

Mode	<a href="#">AUX_IF_CONF.aux_manual_en</a>	<a href="#">PWR_CONF.adv_power_save</a>	<a href="#">PWR_CTRL.aux_en</a>
No auxiliary sensor access	1	1	0
Setup mode	1	0	0
Data mode	0	X	1

[IF\\_CONF.aux\\_en](#) enables (disables) the auxiliary sensor interface. The auxiliary sensor interface operates at 400 kHz. This results in an I2C readout delay of about 250 µs for 10 bytes of data

**Setup mode ([AUX\\_IF\\_CONF.aux\\_manual\\_en =0b1](#))**

Through the primary interface the auxiliary sensor may be accessed using indirect addressing through the AUX\_\* registers. [AUX\\_RD\\_ADDR](#) and [AUX\\_WR\\_ADDR](#) define the address of the register to read/write in the auxiliary sensor register map and triggers the operation itself, when the auxiliary sensor interface is enabled through [PWR\\_CTRL.aux\\_en](#).

For reads, the number of data bytes defined in [AUX\\_IF\\_CONF.aux\\_rd\\_burst](#) are read from the auxiliary sensor and written into the device Register [DATA\\_0](#) to [DATA\\_7](#). For writes only single bytes are written, independent of the settings in [AUX\\_IF\\_CONF.aux\\_rd\\_burst](#). The data for the I2C write to auxiliary sensor must be stored in [AUX\\_WR\\_DATA](#) before the auxiliary sensor register address is written into [AUX\\_WR\\_ADDR](#).

When a read or write operation is triggered by writing to [AUX\\_RD\\_ADDR](#) and [AUX\\_WR\\_ADDR](#), [STATUS.aux\\_busy](#) is set and it is reset when the operation is completed. For reads the [DATA\\_0](#) to [DATA\\_7](#) contains the read data, for writes [AUX\\_WR\\_DATA](#) may be overwritten again.

Configuration phase of the auxiliary sensor.

Example: Read bytes 5 and 6 of auxiliary sensor

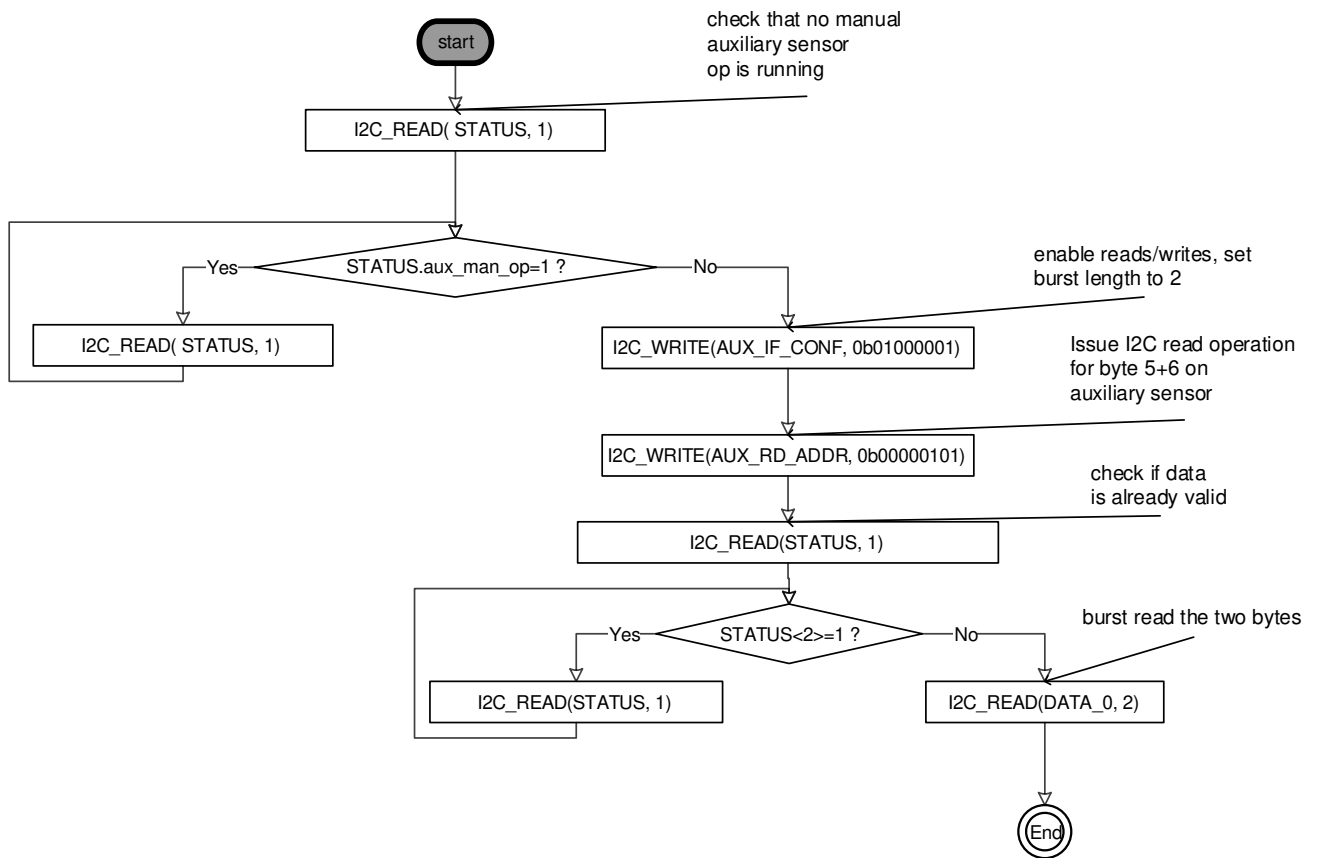

Example: Write 0xEF into byte 3 of auxiliary sensor

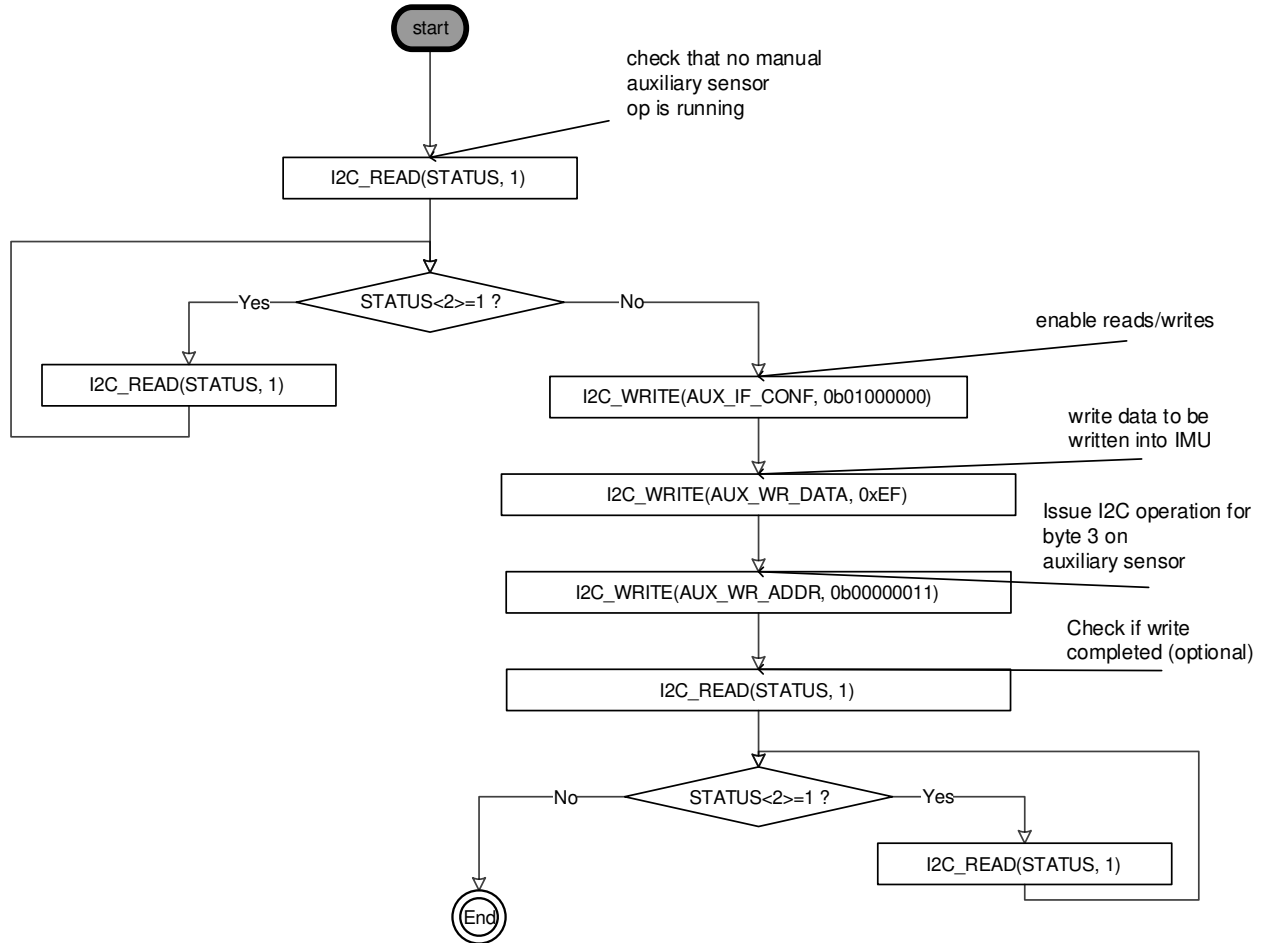

**Data mode ([AUX\\_IF\\_CONF.aux\\_manual\\_en=0](#))**

[AUX\\_RD\\_ADDR.read\\_addr](#) defines the address of the data register from which to read the number of data bytes configured in [AUX\\_IF\\_CONF.aux\\_rd\\_burst](#) from AUX\_0... AUX\_7 data of the auxiliary sensor. These data are stored in the [DATA\\_0](#) up to [DATA\\_7](#) register. the device uses bit 0 of the [DATA\\_6](#) register to determine the data ready status.

The data ready interrupt fires whenever a new data sample set from the AUX sensor is available in Registers [DATA\\_0](#) to [DATA\\_7](#). This allows a low latency data readout. In non-latched mode, the interrupt are cleared automatically after 1/(6400Hz). If this automatic clearance is unwanted, please use latched mode (see Section 4.9). The flag [INT\\_STATUS\\_1.aux\\_drdy\\_int](#) is cleared when the register [INT\\_STATUS\\_1](#) is read. The flag [STATUS.drdy\\_aux](#) is cleared when the Registers [DATA\\_0](#) to [DATA\\_7](#) are read.

To enable the data ready interrupt please map it on the desired INT pin via [INT\\_MAP\\_DATA](#).

[AUX\\_WR\\_ADDR.write\\_addr](#) defines the register address of auxiliary sensor to start a measurement in forced mode in the auxiliary sensor register map. During read and write operations [STATUS.aux\\_busy](#) is set and it is reset, when the operation is completed. The delay (time offset) between triggering an auxiliary sensor measurement and reading the measurement data is specified in [AUX\\_CONF.aux\\_offset](#). Reading of the data is done in a single I2C read operation with a burst length specified in [AUX\\_IF\\_CONF.aux\\_rd\\_burst](#). For BMM150 [AUX\\_IF\\_CONF.aux\\_rd\\_burst](#) should be set to 0b11, i.e. 8 bytes. If [AUX\\_IF\\_CONF.aux\\_rd\\_burst](#) is set to a value lower than 8 bytes, the remaining auxiliary sensor data in the Register [DATA\\_0](#) to [DATA\\_7](#) and the FIFO are undefined.

It is recommended to disable the auxiliary sensor interface ([IF\\_CONF.aux\\_en=0b0](#)) before setting up [AUX\\_RD\\_ADDR.read\\_addr](#) and [AUX\\_WR\\_ADDR.write\\_addr](#) for the data mode. This does not put the auxiliary sensor itself into suspend mode but avoids gathering unwanted data during this phase. Afterwards the auxiliary sensor interface can be enabled ([IF\\_CONF.aux\\_en=0b1](#)) again.

**Delay (Time Offset)**

The device supports starting the measurement of the sensor at the auxiliary sensor interface between 2.5 and 37.5 ms before the Register DATA are updated. This offset is defined in [AUX\\_CONF.aux\\_offset](#). If set to 0b0, the measurement is done right after the last Register DATA update, therefore this measurement will be included in the next register DATA update.

#### 4.11. OIS Interface

The device includes a secondary interface (see Section 6.6 for further details). This may be configured as a dedicated OIS interface. The OIS interface supports phone architectures which share a IMU for a regular host interface (HMI, activity recognition and gesture recognition, PDR, ...) and for optical image stabilization (OIS) at the same time. The OIS interface is a second SPI slave interface, see Section 7.4 for detailed connection diagrams.

The OIS controller has access to low latency accelerometer and gyroscope data through the OIS interface. This is independent of the settings on the host interface. E.g. any settings in the Registers ACC\_CONF and GYR\_CONF will not influence the OIS interface, it remains always in the minimum group delay configuration. With the exception of GYR\_CONF.gyr\_noise\_perf which trades power and noise performance globally for both interfaces, i.e. noise may be reduced w/o compromising group delay. The range of gyroscope data accessible through the OIS interface is independent of the primary interface setting and is configured through GYR\_RANGE.ois\_range. The range of the accelerometer data accessible through the OIS interface is identical to the range setting for the primary interface and configured through ACC\_RANGE.acc\_range.

The use-case for this data is to stabilize photo and video images by real-time motion compensation of the camera lenses.

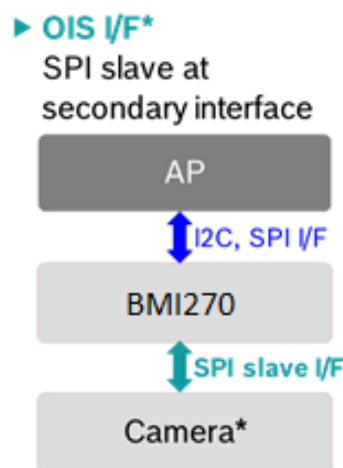

Figure 8: OIS interface

\*) supported by the marked leading providers of OIS controllers.

By default, the OIS interface is in disabled state. If the system design requires an OIS interface, the host enables it by `IF_CONF.ois_en=0b1`. If the OIS interface is enabled the sensors may be controlled both through the host controller and the OIS controller. The OIS controller has access to a dedicated OIS register map.

The OIS data are controlled through the register `OIS_CTRL_S`. This includes enabling and disabling the accelerometer and gyroscope.

The IMU sensor signals for the OIS use case are provided through the secondary interface (in registers `OIS_DATA`, OIS Register Map, see following subsection)

Table 16: OIS Register Map

## OIS Register Map

			read/write		read only		write only		reserved	
Register Address	Register Name	Default Value	7	6	5	4	3	2	1	0
0x7F			reserved							
...			reserved							
0x41			reserved							
0x40	<a href="#">OIS_CTRL_S</a>	0x00	acc_en	gyr_en	reserved					
0x3F		0x00	reserved							
...		0x01	reserved							
0x18		0x00	reserved							
0x17	<a href="#">OIS_DATA_11</a>	0x00	gyr_z_15_8							
0x16	<a href="#">OIS_DATA_10</a>	0x00	gyr_z_7_0							
0x15	<a href="#">OIS_DATA_9</a>	0x00	gyr_y_15_8							
0x14	<a href="#">OIS_DATA_8</a>	0x00	gyr_y_7_0							
0x13	<a href="#">OIS_DATA_7</a>	0x00	gyr_x_15_8							
0x12	<a href="#">OIS_DATA_6</a>	0x00	gyr_x_7_0							
0x11	<a href="#">OIS_DATA_5</a>	0x00	acc_z_15_8							
0x10	<a href="#">OIS_DATA_4</a>	0x00	acc_z_7_0							
0x0F	<a href="#">OIS_DATA_3</a>	0x00	acc_y_15_8							
0x0E	<a href="#">OIS_DATA_2</a>	0x00	acc_y_7_0							
0x0D	<a href="#">OIS_DATA_1</a>	0x00	acc_x_15_8							
0x0C	<a href="#">OIS_DATA_0</a>	0x00	acc_x_7_0							
0x0B		0x00	reserved							
...		-	reserved							
0x00		0x27	reserved							

**Register (0x0C..0x17) OIS\_DATA\_0..11**

## DESCRIPTION:

These 12 registers publish accelerometer and gyroscope data. The register map layout is identical to the host register map (see Section 5, Registers [DATA 8](#) .. [DATA 19](#)). The registers of both register maps are separate instances and thus their content is not a simple copy of each other. The OIS registers provide output data of a separate low latency datapath.

RESET: 0x00

DEFINITION (Go to [register map](#)):

Address	Bit	Name	Description	Reset	Access
0x0C..0x17		OIS_DATA_0..11		0x00	
	7...0		acc_x_7_0 to gyr_z_15_8	0x0	R

**Register (0x40) OIS\_CTRL\_S**

DESCRIPTION: controls the IMU through the OIS interface

RESET: 0x00

DEFINITION (Go to [register map](#)):

Address	Bit	Name	Description	Reset	Access
0x40		OIS_CTRL_S		0x00	
	7	acc_en	Enables accelerometer via OIS interface in registers OIS_DATA_0 till OIS_DATA_5 with minimum group delay @ 1.6KHz ODR	0x0	RW
	6	gyr_en	Enables gyroscope via OIS interface in registers OIS_DATA_6 till OIS_DATA_11 with minimum group delay @ 6.4KHz ODR	0x0	RW

## 4.12. Sensor Self-Test

### Accelerometer

Activating the self-test results in a static offset of the acceleration data. Any external acceleration or gravitational force applied to the sensor during active self-test will be observed in the output as a superposition of both acceleration and self-test signal.

The recommended self test procedure is as follows:

1. Enable accelerometer with register [PWR\\_CTRL.acc\\_en](#)=1b1.
2. Set  $\pm 16g$  range in register [ACC\\_RANGE.acc\\_range](#)
3. Set self test amplitude to high by setting [ACC\\_SELF\\_TEST.acc\\_self\\_test\\_amp](#) = 1b1
4. Set [ACC\\_CONF.acc\\_odr](#)=1600Hz, Continuous sampling mode, [ACC\\_CONF.acc\\_bwp](#)=norm\_avg4, [ACC\\_CONF.acc\\_filter\\_perf](#)=1b1.
5. Wait for > 2 ms
6. Set positive self-test polarity ([ACC\\_SELF\\_TEST.acc\\_self\\_test\\_sign](#)= 1b1)
7. Enable self-test [ACC\\_SELF\\_TEST.acc\\_self\\_test\\_en](#) = 1b1
8. Wait for > 50ms
9. Read and store positive acceleration value of each axis from registers [DATA 8](#) to [DATA 13](#)
10. Set negative self-test polarity [ACC\\_SELF\\_TEST.acc\\_self\\_test\\_sign](#)= 1b0)
11. Enable self-test [ACC\\_SELF\\_TEST.acc\\_self\\_test\\_en](#) = 1b1
12. Wait for > 50ms
13. Read and store negative acceleration value of each axis from registers [DATA 8](#) to [DATA 13](#)
14. Calculate difference of positive and negative acceleration values and compare against minimum difference signal values defined in the table below
15. Disable self-test [ACC\\_SELF\\_TEST.acc\\_self\\_test\\_en](#) = 1b0

The table below shows the minimum differences for each axis in order for the self test to pass. The actually measured signal differences can be significantly larger.

Self-test: Resulting minimum difference signal

	x-axis signal	y-axis signal	z-axis signal
Accelerometer	> +16g	< -15g	> +10g

It is recommended to perform a reset of the device after a self-test has been performed. If the reset cannot be performed, the following sequence must be kept to prevent unwanted interrupt generation: disable interrupts, change parameters of interrupts, wait for at least 50ms, and enable desired interrupts.



## Gyroscope

The gyroscope self test consists of independent parts, a drive test, a sense test, and a datapath test.

To perform a gyroscope self-test

1. Issue a soft reset (see Section 4.17) or a power-on reset (POR) (see Section 4.4)
2. Initialize device (see Section 4.4)
3. Disable APS [PWR\\_CONF.adv\\_power\\_save=0b0](#) and wait for 450us
4. Enable accelerometer [PWR\\_CTRL.acc\\_en=0b1](#)
5. Ensure that the device is at rest during self-test execution
6. Send *g\_trigger* command using the register [CMD](#)
7. Self-test is complete, after the device sets [GYR\\_SELF\\_TEST\\_AXES.gyr\\_st\\_axes\\_done=0b1](#)
8. [GYR\\_GAIN\\_STATUS.g\\_trig\\_status](#) reports a successful self-test or execution errors
9. The test passed if all axes report the status “ok” by [GYR\\_SELF\\_TEST\\_AXES.gyr\\_axis \[xyz\]\\_ok=0b1](#).

During the gyroscope self-test described above and at every gyroscope startup, i.e.:

- [PWR\\_CTRL.gyr\\_en](#): 0b0->0b1 and [PWR\\_CONF.fup\\_en](#)==0b0  
or
- [PWR\\_CONF.fup\\_en](#): 0b0->0b1 and [PWR\\_CTRL.gyr\\_en](#)==0b0

a drive test is automatically performed and if it fails it is reported through [ERR\\_REG.fatal\\_err](#) latest after 320 ms.

## 4.13. Offset Compensation

### Accelerometer

The device offers manual compensation as well as inline calibration.

Offset compensation is performed with pre-filtered data, and the offset is then applied to both, pre-filtered and filtered data. If necessary the result of this computation is saturated to prevent any overflow errors (the smallest or biggest possible value is set, depending on the sign).

The offset compensation Registers [OFFSET\\_0](#) to [OFFSET\\_2](#) are images of the corresponding registers in the NVM. With each image update the contents of the NVM registers are written to the public registers. The public registers can be overwritten by the user at any time.

The offset compensation registers have a width of 8 bit using two's complement notation. The offset resolution (LSB) is 3.9 mg and the offset range is +- 0.5 g. Both are independent of the range setting. Offset compensation needs to be enabled through [NV\\_CONF.acc\\_off\\_en](#) = 0b1

#### *Manual Offset Compensation*

The contents of the public compensation Register [OFFSET\\_0](#) to [OFFSET\\_2](#) may be set manually via the digital interface. After modifying the Register [OFFSET\\_0](#) to [OFFSET\\_2](#) the next data sample is not valid.

Offset compensation needs to be enabled through [NV\\_CONF.acc\\_off\\_en](#).

#### *Fast Offset Compensation FOC (Semi-Automatic Offset Compensation)*

For certain applications, it is often desirable to calibrate the offset once and to store the compensation values permanently. This can be achieved by using manual offset compensation to determine the proper compensation values and then storing these values permanently in the NVM.

Each time the device is reset, the compensation values are loaded from the non-volatile memory into the image registers and used for offset compensation.

### Gyroscope

Offset compensation is performed with pre-filtered data, and the offset is then applied to both, pre-filtered and filtered data. If necessary the result of this computation is saturated to prevent any overflow errors (the smallest or biggest possible value is set, depending on the sign).

The offset compensation Registers [OFFSET\\_3](#) to [OFFSET\\_6](#) are images of the corresponding registers in the NVM. With each image update the contents of the NVM registers are written to the public registers. The public registers can be overwritten by the user at any time.

The offset compensation field for each axis has a width of 10 bit using two's complement notation. The offset resolution (LSB) is 61 mdps and the offset range is +- 31 dps. Both are independent of the range setting.

Offset compensation needs to be enabled through [OFFSET\\_6.gyr\\_off\\_en](#).

#### *Manual Offset Compensation*

The contents of the compensation Register [OFFSET\\_3](#) to [OFFSET\\_6](#) may be set manually via the digital interface. After modifying the Register [OFFSET\\_3](#) to [OFFSET\\_6](#) the next data sample is not valid. Offset compensation needs to be enabled through [OFFSET\\_6.gyr\\_off\\_en](#).

#### *Fast Offset Compensation FOC (Semi-Automatic Offset Compensation)*

For certain applications, it is often desirable to calibrate the offset once and to store the compensation values permanently. This can be achieved by using manual offset compensation to determine the proper compensation values and then storing these values permanently in the NVM.

Each time the device is reset, the compensation values are loaded from the non-volatile memory into the image registers and used for offset compensation.

#### *In-use Offset Compensation IOC (Full-Automatic Offset Compensation)*

MEMS devices typically show offset drifts due to thermomechanical stress effects within the application, the use-case or over lifetime. To compensate such potential drifts the device offers an in-use offset compensation (IOC), which operates fully autonomous without any necessary host interaction and in parallel to the normal device operation.

The host can choose to use either the built-in full automatic IOC feature to compensate the gyroscope offset in registers [OFFSET 3](#) ... [OFFSET 6](#) or control these registers manually. This is controlled by the Register [GEN SET 1.gyro\\_self\\_off](#).

The device will update the gyroscope offset registers automatically if all of the following conditions are met (host should not update the registers [OFFSET 3](#) ... [OFFSET 6](#) when this feature is enabled):

- Bit [GEN SET 1.gyro\\_self\\_off](#) is 1
- Bit [OFFSET 6.gyr\\_off\\_en](#) is 1
- Accelerometer is enabled from either primary or OIS interface
- Gyroscope is enabled from primary interface
- Gyroscope is disabled from OIS interface

If any one of the above conditions are not met, then the feature is disabled. In this case, host can update the gyroscope offset registers. The recommended way to disable this feature is to clear the [GEN SET 1.gyro\\_self\\_off](#) bit to 0.

#### 4.14. Sensitivity Error Compensation

##### Accelerometer

The device supports an ultra-low sensitivity (gain) compensation already by design. Refer to Section 1.

##### Gyroscope

The device supports sensitivity (gain) compensation (e.g. to compensate for a soldering drift). This can be done either manually by rotating the device and comparing against a known reference or motionless using CRT (*Component ReTrim*).

##### Manual SENS Error Compensation

The device supports correcting the sensitivity difference, with respect to the reference system using manual SENS error compensation. Assuming the offset of the gyro is compensated, gain compensation is enabled ([OFFSET6.gyr\\_gain\\_en=0b1](#)) and the gyroscope reports  $\omega_m$ , whereas the reference system reports  $\omega_r$ , the host must supply the rate ratios  $\omega_{r[x-z]}/\omega_{m[x-z]}$  in the Registers [GYR\\_GAIN\\_UPD \[1-3\]](#). The encoding is given by

- a. Bit width = 11 bits (FxF representation is 1.10)
- b. Resolution =  $0.0009765 = 2^{-10}$  (i.e. 0.09765% i.e. <0.1%)
- c. Range = 0.75 .. 1.25 (i.e. 1 +/- 25%)  
e.g. 1+25% = 1.25 is represented as

b10	b9	b8	b7	b6	b5	b4	b3	b2	b1	b0
1	0	1	0	0	0	0	0	0	0	0

e.g. 1+0.09765% = 1.0009765 is represented as

b10	b9	b8	b7	b6	b5	b4	b3	b2	b1	b0
1	0	0	0	0	0	0	0	0	0	1

e.g. 1-0.09765% = 0.9990234 is represented as

b10	b9	b8	b7	b6	b5	b4	b3	b2	b1	b0
0	1	1	1	1	1	1	1	1	1	1

e.g. 1-25% = 0.75 is represented as

b10	b9	b8	b7	b6	b5	b4	b3	b2	b1	b0
0	1	1	0	0	0	0	0	0	0	0

The host must enable the update operation via Register [GYR\\_GAIN\\_UPD 3.enable](#) =0b1 and disable the gyroscope ([PWR\\_CTRL.gyr\\_en](#)=0b0) before triggering the manual SENS error compensation operation via issuing a command *usr\_gain* to the Register [CMD](#). After [GYR\\_GAIN\\_UPD 3.enable](#) bit gets cleared, the operation is completed, and the host can reenble the gyroscope ([PWR\\_CTRL.gyr\\_en](#)=0b1)

In case the compensation reaches the compensation range limit, the device reports this through Register [GYR\\_GAIN\\_STATUS](#).

This compensated sensitivity value may be retained over power cycles by storing it in NVM, see Section 4.15 for details.

### **Component ReTrimming Feature CRT (Fast, motionless SENS Error Compensation)**

For motionless SENS error compensation (CRT) the following flow needs to be executed:

1. Issue a soft reset (see Section 4.17) or a power-on reset (POR) (see Section 4.4)
2. Initialize device (see Section 4.4)
3. Disable APS [PWR\\_CONF.adv\\_power\\_save=0b0](#) and wait for 450us
4. Enable accelerometer [PWR\\_CTRL.acc\\_en=0b1](#)
5. Ensure that the device is at rest during CRT execution
6. Set [GYR\\_CRT\\_CONF.crt\\_running=0b1](#)
7. Set [G\\_TRIG\\_1.select=1](#)
8. Set [G\\_TRIG\\_1.block=0](#)
9. Send *g\_trigger* command using the register [CMD](#)
10. CRT is complete, after the device sets [GYR\\_CRT\\_CONF.crt\\_running=0b0](#)
11. [GYR\\_GAIN\\_STATUS.g\\_trig\\_status](#) reports a successful CRT run or execution errors
12. Optionally, the new gyroscope gain values can be programmed to NVM. See Section 4.15 for details about NVM programming.
13. The new gain values are applied automatically at the next start of the gyroscope.

If the device detects motion during the CRT flow, the operation is aborted and the gain remains unchanged. If CRT is abort, Register [GYR\\_GAIN\\_STATUS.g\\_trig\\_status](#) will be set to 0x03.

CRT may run in the full operating temperature range. We recommend to run CRT at the operating temperature of the device. The sensitivity error is typically minimal at the temperature CRT was performed at.

We recommend performing CRT according the description above for one-time CRT calibration. Both one-time and repeated CRT is supported by the device.

## **4.15. Non-Volatile Memory**

The registers [NV\\_CONF\\_OFFSET\\_0](#) to [OFFSET\\_6](#), [AUX\\_IF\\_TRIM](#), and [DRV](#) have an NVM backup which are accessible by the user. In addition, the registers for the sensitivity error compensation for the gyroscope are included in the NVM backup (see Section 4.14).

The content of the NVM is loaded to the image registers after a reset (either POR or softreset). As long as the image update is in progress, [STATUS.cmd\\_rdy](#) is 0b0, otherwise it is 0b1.

The image registers can be read and written like any other register.

Writing to the NVM is a 4-step procedure:

1. Set [PWR\\_CONF.adv\\_power\\_save](#) = 0b0
2. Write the new contents to the image registers.
3. Prepare NVM write by setting [GEN\\_SET\\_1.nvm\\_prog\\_prep](#) =0b1
4. Wait 40 ms
5. Write 0b1 to bit [NVM\\_CONF.nvm\\_prog\\_en](#) in order to unlock the NVM.
6. Write *prog\_nvm* to the [CMD](#) register to trigger the write process.
7. Power off or restart the device e.g. POR/ Softreset; see Section 4.4 / 4.17

Writing to the NVM always renews the entire NVM contents and is limited in write cycles. It is possible to check the write status by reading [STATUS.cmd\\_rdy](#). While [STATUS.cmd\\_rdy](#) = 0b0, the write process is still in progress; when [STATUS.cmd\\_rdy](#) = 0b1, writing is completed. An NVM write cycle can only be initiated, if [PWR\\_CONF.adv\\_power\\_save](#) = 0b0.

Until boot phase is finished (after POR or softreset), the serial interface is not operational. The NVM shadow registers must not be accessed during an ongoing NVM command (initiated through the Register [CMD](#)). In all other cases, register can be read or written.

As long as an NVM read (during sensor boot and soft reset) or an NVM write is ongoing, writes to sensor registers are discarded, reads return the Register [STATUS](#) independent of the read address.

## 4.16. Error Reporting

Device errors during operation are reported through the registers [ERR\\_REG](#) (hardware errors), [EVENT](#) (POR and invalid configuration events), [INTERNAL\\_STATUS](#) (initialization and invalid configuration), and [INTERNAL\\_ERROR](#) (unexpected behavior). Reserved bits in the error registers are for Bosch Sensortec internal purposes and can be ignored.

The register [ERR\\_REG\\_MSK](#) controls which bits in Register [ERR\\_REG](#) trigger an interrupt. Register [INT\\_MAP\\_DATA.err\\_int1](#) and [INT\\_MAP\\_DATA.err\\_int2](#) defines on which interrupt pin, the error interrupt is mapped.

Illegal settings in configuration registers [ACC\\_CONF](#) and [GYR\\_CONF](#) will result in an error code in Register [EVENT](#). The content of the data register is undefined.

Sensor Self-Test errors are covered in Section 4.12.

## 4.17. Soft-Reset

A softreset can be initiated at any time by writing the command *softreset* (0xB6) to register [CMD](#). The softreset performs a fundamental reset to the device which is largely equivalent to a power cycle. Following a delay, all user configuration settings are overwritten with their default state (setting stored in the NVM) wherever applicable. This command is functional in all operation modes but must not be performed while NVM writing operation is in progress.

To access the SPI or I2C interface after a soft-reset, the same timing constraints apply as for power on, see Section 1 for details.

## 5. Register Description

### 5.1. General Remarks

This section contains register definitions. REG[x]<y> denotes bit y in byte x in register REG. Val(Name) is the value contained in the register interpreted as non-negative binary number. When writing to reserved bits, the reset value should be written if not stated different.

For most of the registers auto address increment applies for, with the exception of the registers below, which trap the address:

- [FIFO\\_DATA](#)
- [INIT\\_DATA](#)

Register read from a burst read must remain consistent. In order to ensure this, when a read starts in one register of a group, the registers in this group are shadowed:

- [STATUS](#), [DATA\\_x](#), [SENSORTIME\\_x](#), [TEMPERATURE\\_x](#), [SC\\_OUT\\_x](#), [FIFO\\_LENGTH\\_x](#)
- [FEATURES](#)

The registers listed below are clear-on-read:

- [ERR\\_REG](#)
- [STATUS.drdy\\_acc](#) (cleared when [DATA\\_9.acc\\_x\\_15\\_8](#) is read),
- [STATUS.drdy\\_gyr](#) (cleared when [DATA\\_15.gyr\\_x\\_15\\_8](#) is read)
- [STATUS.drdy\\_aux](#) (cleared when [DATA\\_1.aux\\_x\\_15\\_8](#) is read)
- [EVENT](#)
- [INT\\_STATUS\\_0](#)
- [INT\\_STATUS\\_1](#)

The register clearance happens, when bit 0 of the corresponding register is read.

### 5.2. Register Map

read/write	read only	write only	reserved
------------	-----------	------------	----------

Corresponding to BMI270\_main.tbin version: 4.8

Register Address	Register Name	Default Value	7	6	5	4	3	2	1	0	
0x7E	<a href="#">CMD</a>	0x00	cmd								
0x7D	<a href="#">PWR_CTL</a>	0x00	reserved				temp_en	acc_en	gyr_en	aux_en	
0x7C	<a href="#">PWR_CONFE</a>	0x03	reserved					fup_en	fifo_self_wake_up	adv_power_save	
0x7B	-	-	reserved								
...	-	-	reserved								
0x78	-	-	reserved								
0x77	<a href="#">OFFSET 6</a>	0x00	gyr_gain_en	gyr_off_en	gyr_usr_off_z_9_8		gyr_usr_off_y_9_8		gyr_usr_off_x_9_8		
0x76	<a href="#">OFFSET 5</a>	0x00	gyr_usr_off_z_7_0								
0x75	<a href="#">OFFSET 4</a>	0x00	gyr_usr_off_y_7_0								
0x74	<a href="#">OFFSET 3</a>	0x00	gyr_usr_off_x_7_0								
0x73	<a href="#">OFFSET 2</a>	0x00	off_acc_z								
0x72	<a href="#">OFFSET 1</a>	0x00	off_acc_y								
0x71	<a href="#">OFFSET 0</a>	0x00	off_acc_x								
0x70	<a href="#">NV_CONF</a>	0x00	reserved				acc_off_en	i2c_wdt_en	i2c_wdt_sel	spi_en	
0x6F	-	-	reserved								
0x6E	<a href="#">GYR_SELF_TEST_AXES</a>	0x00	reserved				gyr_axis_z_ok	gyr_axis_y_ok	gyr_axis_x_ok	gyr_st_axes_done	
0x6D	<a href="#">ACC_SELF_TEST</a>	0x00	reserved				acc_self_test_amp	acc_self_test_sig	reserved	acc_self_test_en	
0x6C	<a href="#">DRV</a>	0xFF	io_pad_i2c_b2	io_pad_drv2			io_pad_i2c_b1	io_pad_drv1			
0x6B	<a href="#">IF_CONF</a>	0x00	reserved		aux_en	ois_en	reserved		spi3_ois	spi3	
0x6A	<a href="#">NVM_CONFIG</a>	0x00	reserved							nvm_prog_en	reserved
0x69	<a href="#">GYR_CRT_CONF</a>	0x00	reserved				rdy_for_dl	crt_running	reserved		
0x68	<a href="#">AUX_IF_TRIM</a>	0x01	reserved					spare3	asda_pupsel		
0x67	-	-	reserved								
...	-	-	reserved								
0x60	-	-	reserved								
0x5F	<a href="#">INTERNAL_ERROR</a>	0x00	reserved			feat_eng_disabled	reserved	int_err_2	int_err_1	reserved	



0x5E	<a href="#">INIT_DATA</a>	0x00	data							
0x5D	-	-	reserved							
0x5C	<a href="#">INIT_ADDR_1</a>	0x00	base_11_4							
0x5B	<a href="#">INIT_ADDR_0</a>	0x00	reserved				base_0_3			
0x5A	-	-	reserved							
0x59	<a href="#">INIT_CTRL</a>	0x00	init_ctrl							
0x58	<a href="#">INT_MAP_DATA</a>	0x00	err_int2	drdy_int2	fwm_int2	ffull_int2	err_int1	drdy_int1	fwm_int1	ffull_int1
0x57	<a href="#">INT2_MAP_FEAT</a>	0x00	reserved	any_motion_out	no_motion_out	wrist_gesture_out	wrist_wake_up_out	activity_out	step_counter_out	sig_motion_out
0x56	<a href="#">INT1_MAP_FEAT</a>	0x00	reserved	any_motion_out	no_motion_out	wrist_gesture_out	wrist_wake_up_out	activity_out	step_counter_out	sig_motion_out
0x55	<a href="#">INT_LATCH</a>	0x00	reserved							int_latch
0x54	<a href="#">INT2_IO_CTRL</a>	0x00	reserved			input_en	output_en	od	lvl	reserved
0x53	<a href="#">INT1_IO_CTRL</a>	0x00	reserved			input_en	output_en	od	lvl	reserved
0x52	<a href="#">ERR_REG_MSK</a>	0x00	aux_err	fifo_err	reserved	internal_err			fatal_err	
0x51	-	-	reserved							
0x50	-	-	reserved							
0x4F	<a href="#">AUX_WR_DATA</a>	0x02	write_data							
0x4E	<a href="#">AUX_WR_ADDR</a>	0x4C	write_addr							
0x4D	<a href="#">AUX_RD_ADDR</a>	0x42	read_addr							
0x4C	<a href="#">AUX_IF_CONF</a>	0x83	aux_manual_en	aux_fcw_write_en	reserved		man_rd_burst		aux_rd_burst	
0x4B	<a href="#">AUX_DEV_ID</a>	0x20	i2c_device_addr							reserved
0x4A	<a href="#">SATURATION</a>	0x00	reserved		gyr_z	gyr_y	gyr_x	acc_z	acc_y	acc_x
0x49	<a href="#">FIFO_CONFIG_1</a>	0x10	fifo_gyr_en	fifo_acc_en	fifo_aux_en	fifo_header_en	fifo_tag_int2_en		fifo_tag_int1_en	
0x48	<a href="#">FIFO_CONFIG_0</a>	0x02	reserved						fifo_time_en	fifo_stop_on_full
0x47	<a href="#">FIFO_WTM_1</a>	0x02	reserved			fifo_water_mark_12_8				
0x46	<a href="#">FIFO_WTM_0</a>	0x00	fifo_water_mark_7_0							
0x45	<a href="#">FIFO_DOWNS</a>	0x88	acc_fifo_filter_data	acc_fifo_downs			gyr_fifo_filter_data	gyr_fifo_downs		

0x44	<a href="#">AUX_CON F</a>	0x46	aux_offset				aux_odr				
0x43	<a href="#">GYR_RAN GE</a>	0x00	reserved				ois_rang e	gyr_range			
0x42	<a href="#">GYR_CON F</a>	0xA9	gyr_filter _perf	gyr_nois e_perf	gyr_bwp		gyr_odr				
0x41	<a href="#">ACC_RAN GE</a>	0x02	reserved						acc_range		
0x40	<a href="#">ACC_CON F</a>	0xA8	acc_filde r_perf	acc_bwp			acc_odr				
0x3F	<a href="#">FEATURES [15]</a>	0x00	features_in_out								
...	...	-									
0x30	<a href="#">FEATURES [0]</a>	0x00									
0x2F	<a href="#">FEAT_PAG E</a>	0x00	reserved					page			
0x2E	-	-	reserved								
...	-	-	reserved								
0x27	-	-	reserved								
0x26	<a href="#">FIFO_DATA</a>	0x00	fifo_data								
0x25	<a href="#">FIFO_LEN GTH_1</a>	0x00	reserved		fifo_byte_counter_13_8						
0x24	<a href="#">FIFO_LEN GTH_0</a>	0x00	fifo_byte_counter_7_0								
0x23	<a href="#">TEMPERAT URE_1</a>	0x80	tmp_data_15_8								
0x22	<a href="#">TEMPERAT URE_0</a>	0x00	tmp_data_7_0								
0x21	<a href="#">INTERNAL STATUS</a>	0x00	Reserve d	odr_50h z_error	axes_re map_err or	Reserve d	message				
0x20	<a href="#">WR_GEST ACT</a>	0x00	reserved			act_out		wr_gest_out			
0x1F	<a href="#">SC_OUT_1</a>	0x00	byte_1								
0x1E	<a href="#">SC_OUT_0</a>	0x00	byte_0								
0x1D	<a href="#">INT_STATU S_1</a>	0x00	acc_drd y_int	gyr_drdy _int	aux_drd y_int	reserved		err_int	fwm_int	ffull_int	
0x1C	<a href="#">INT_STATU S_0</a>	0x00	reserved	any_mot ion_out	no_moti on_out	wrist_ge sture_ou t	wrist_we ar_wake up_out	activity_ out	step_co unter_ou t	sig_moti on_out	
0x1B	<a href="#">EVENT</a>	0x01	reserved			error_code			reserved	por_dete cted	
0x1A	<a href="#">SENSORTI ME_2</a>	0x00	sensor_time_23_16								
0x19	<a href="#">SENSORTI ME_1</a>	0x00	sensor_time_15_8								
0x18	<a href="#">SENSORTI ME_0</a>	0x00	sensor_time_7_0								

0x17	<a href="#">DATA 19</a>	0x00	gyr_z_15_8						
0x16	<a href="#">DATA 18</a>	0x00	gyr_z_7_0						
0x15	<a href="#">DATA 17</a>	0x00	gyr_y_15_8						
0x14	<a href="#">DATA 16</a>	0x00	gyr_y_7_0						
0x13	<a href="#">DATA 15</a>	0x00	gyr_x_15_8						
0x12	<a href="#">DATA 14</a>	0x00	gyr_x_7_0						
0x11	<a href="#">DATA 13</a>	0x00	acc_z_15_8						
0x10	<a href="#">DATA 12</a>	0x00	acc_z_7_0						
0x0F	<a href="#">DATA 11</a>	0x00	acc_y_15_8						
10x0E	<a href="#">DATA 10</a>	0x00	acc_y_7_0						
0x0D	<a href="#">DATA 9</a>	0x00	acc_x_15_8						
0x0C	<a href="#">DATA 8</a>	0x00	acc_x_7_0						
0x0B	<a href="#">DATA 7</a>	0x00	aux_r_15_8						
0x0A	<a href="#">DATA 6</a>	0x00	aux_r_7_0						
0x09	<a href="#">DATA 5</a>	0x00	aux_z_15_8						
0x08	<a href="#">DATA 4</a>	0x00	aux_z_7_0						
0x07	<a href="#">DATA 3</a>	0x00	aux_y_15_8						
0x06	<a href="#">DATA 2</a>	0x00	aux_y_7_0						
0x05	<a href="#">DATA 1</a>	0x00	aux_x_15_8						
0x04	<a href="#">DATA 0</a>	0x00	aux_x_7_0						
0x03	<a href="#">STATUS</a>	0x10	drdy_ac c	drdy_gyr	drdy_au x	cmd_rdy	reserved	aux_bus y	reserved
0x02	<a href="#">ERR REG</a>	0x00	aux_err	fifo_err	reserved	internal_err			fatal_err
0x01	-	-	reserved						
0x00	<a href="#">CHIP_ID</a>	0x24	chip_id						

## FEATURES Pages

Register Address	Register Name	Page 0	Page 1	Page 2	Page 3
0x30	<a href="#">FEATURES[0,1]</a>	<a href="#">SC_OUT_0_1</a>	<a href="#">Reserved</a>	<a href="#">NOMO_1</a>	<a href="#">SC_1</a>
0x32	<a href="#">FEATURES[2,3]</a>	<a href="#">SC_OUT_2_3</a>	<a href="#">G_TRIG_1</a>	<a href="#">NOMO_2</a>	<a href="#">SC_2</a>
0x34	<a href="#">FEATURES[4,5]</a>	<a href="#">ACT_OUT</a>	<a href="#">GEN_SET_1</a>	<a href="#">SIGMO_1</a>	<a href="#">SC_3</a>
0x36	<a href="#">FEATURES[6,7]</a>	<a href="#">WR_GEST_OUT</a>	<a href="#">GYR_GAIN_UPD_1</a>	<a href="#">Reserved</a>	<a href="#">SC_4</a>
0x38	<a href="#">FEATURES[8,9]</a>	<a href="#">GYR_GAIN_STATUS</a>	<a href="#">GYR_GAIN_UPD_2</a>	<a href="#">Reserved</a>	<a href="#">SC_5</a>
0x3A	<a href="#">FEATURES[10,11]</a>	<a href="#">Reserved</a>	<a href="#">GYR_GAIN_UPD_3</a>	<a href="#">Reserved</a>	<a href="#">SC_6</a>
0x3C	<a href="#">FEATURES[12,13]</a>	<a href="#">GYR_CAS</a>	<a href="#">ANYMO_1</a>	<a href="#">Reserved</a>	<a href="#">SC_7</a>
0x3E	<a href="#">FEATURES[14,15]</a>	<a href="#">Reserved</a>	<a href="#">ANYMO_2</a>	<a href="#">SIGMO_2</a>	<a href="#">SC_8</a>

## FEATURES Pages

Register Address	Register Name	Page 4	Page 5	Page 6	Page 7
0x30	<a href="#">FEATURES[0,1]</a>	<a href="#">SC_9</a>	<a href="#">SC_17</a>	<a href="#">SC_25</a>	<a href="#">WR_WAKEUP_1</a>
0x32	<a href="#">FEATURES[2,3]</a>	<a href="#">SC_10</a>	<a href="#">SC_18</a>	<a href="#">SC_26</a>	<a href="#">WR_WAKEUP_2</a>
0x34	<a href="#">FEATURES[4,5]</a>	<a href="#">SC_11</a>	<a href="#">SC_19</a>	<a href="#">SC_27</a>	<a href="#">WR_WAKEUP_3</a>
0x36	<a href="#">FEATURES[6,7]</a>	<a href="#">SC_12</a>	<a href="#">SC_20</a>	<a href="#">WR_GEST_1</a>	<a href="#">WR_WAKEUP_4</a>
0x38	<a href="#">FEATURES[8,9]</a>	<a href="#">SC_13</a>	<a href="#">SC_21</a>	<a href="#">WR_GEST_2</a>	<a href="#">WR_WAKEUP_5</a>
0x3A	<a href="#">FEATURES[10,11]</a>	<a href="#">SC_14</a>	<a href="#">SC_22</a>	<a href="#">WR_GEST_3</a>	<a href="#">WR_WAKEUP_6</a>
0x3C	<a href="#">FEATURES[12,13]</a>	<a href="#">SC_15</a>	<a href="#">SC_23</a>	<a href="#">WR_GEST_4</a>	<a href="#">WR_WAKEUP_7</a>
0x3E	<a href="#">FEATURES[14,15]</a>	<a href="#">SC_16</a>	<a href="#">SC_24</a>	<a href="#">Reserved</a>	<a href="#">Reserved</a>

### Register (0x00) CHIP\_ID

DESCRIPTION: Chip identification code

RESET: 0x24

DEFINITION (Go to [register map](#)):

Address	Bit	Name	Description	Reset	Access
0x00		CHIP_ID		0x24	
	7...0	chip_id	Chip identification code	0x24	R

### Register (0x02) ERR\_REG

DESCRIPTION: Reports sensor error conditions

RESET: 0x00

DEFINITION (Go to [register map](#)):

Address	Bit	Name	Description	Reset	Access
0x02		ERR_REG		0x00	
	0	fatal_err	Fatal Error, chip is not in operational state (Boot-, power-system). This flag will be reset only by power-on-reset or softreset.	0x0	R
	4...1	internal_err	Internal error, please contact your Bosch Sensortec regional support team.	0x0	R
	6	fifo_err	Error when a frame is read in streaming mode (so skipping is not possible) and fifo is overfilled (with virtual and/or regular frames). This flag will be reset when read.	0x0	R
	7	aux_err	Error in I2C-Master detected. This flag will be reset when read.	0x0	R

## Register (0x03) STATUS

DESCRIPTION: Sensor status flags

RESET: 0x10

DEFINITION (Go to [register map](#)):

Address	Bit	Name	Description	Reset	Access
0x03		STATUS		0x10	
	2	aux_busy	'1'('0') indicate a (no) Auxiliary sensor interface operation is ongoing triggered via AUX_RD_ADDR, AUX_WR_ADDR or from FCU.	0x0	R
	4	cmd_rdy	CMD decoder status. '0' -> Command in progress '1' -> Command decoder is ready to accept a new command	0x1	R
	5	drdy_aux	Data ready for Auxiliary sensor. It gets reset, when one Auxiliary sensor DATA register is read out	0x0	R
	6	drdy_gyr	Data ready for Gyroscope. It gets reset, when one Gyroscope DATA register is read out	0x0	R
	7	drdy_acc	Data ready for Accelerometer. It gets reset, when one Accelerometer DATA register is read out	0x0	R

## Register (0x04) DATA\_0

DESCRIPTION: AUX\_X(LSB)

RESET: 0x00

DEFINITION (Go to [register map](#)):

Address	Bit	Name	Description	Reset	Access
0x04		DATA_0		0x00	
	7...0	aux_x_7_0	copy of register Val(AUX_IF[1]) in Auxiliary sensor register map.	0x0	R

## Register (0x05) DATA\_1

DESCRIPTION: AUX\_X(MSB)

RESET: 0x00

DEFINITION (Go to [register map](#)):

Address	Bit	Name	Description	Reset	Access
0x05		DATA_1		0x00	
	7...0	aux_x_15_8	copy of register Val(AUX_IF[1])+1 in Auxiliary sensor register map	0x0	R

## Register (0x06) DATA\_2

DESCRIPTION: AUX\_Y(LSB)

RESET: 0x00

DEFINITION (Go to [register map](#)):

Address	Bit	Name	Description	Reset	Access
0x06		DATA_2		0x00	
	7...0	aux_y_7_0	copy of register Val(AUX_IF[1])+2 in Auxiliary sensor register map	0x0	R

## Register (0x07) DATA\_3

DESCRIPTION: AUX\_Y(MSB)

RESET: 0x00

DEFINITION (Go to [register map](#)):

Address	Bit	Name	Description	Reset	Access
0x07		DATA_3		0x00	
	7...0	aux_y_15_8	copy of register Val(AUX_IF[1])+3 in Auxiliary sensor register map	0x0	R

## Register (0x08) DATA\_4

DESCRIPTION: AUX\_Z(LSB)

RESET: 0x00

DEFINITION (Go to [register map](#)):

Address	Bit	Name	Description	Reset	Access
0x08		DATA_4		0x00	
	7...0	aux_z_7_0	copy of register Val(AUX_IF[1])+4 in Auxiliary sensor register map	0x0	R

## Register (0x09) DATA\_5

DESCRIPTION: AUX\_Z(MSB)

RESET: 0x00

DEFINITION (Go to [register map](#)):

Address	Bit	Name	Description	Reset	Access
0x09		DATA_5		0x00	
	7...0	aux_z_15_8	copy of register Val(AUX_IF[1])+5 in Auxiliary sensor register map	0x0	R

## Register (0x0A) DATA\_6

DESCRIPTION: AUX\_R(LSB)

RESET: 0x00

DEFINITION (Go to [register map](#)):

Address	Bit	Name	Description	Reset	Access
0x0A		DATA_6		0x00	
	7...0	aux_r_7_0	copy of register Val(AUX_IF[1])+6 in Auxiliary sensor register map	0x0	R

## Register (0x0B) DATA\_7

DESCRIPTION: AUX\_R(MSB)

RESET: 0x00

DEFINITION (Go to [register map](#)):

Address	Bit	Name	Description	Reset	Access
0x0B		DATA_7		0x00	
	7...0	aux_r_15_8	copy of register Val(AUX_IF[1])+7 in Auxiliary sensor register map	0x0	R

## Register (0x0C) DATA\_8

DESCRIPTION: ACC\_X(LSB)

RESET: 0x00

DEFINITION (Go to [register map](#)):

Address	Bit	Name	Description	Reset	Access
0x0C		DATA_8		0x00	
	7...0	acc_x_7_0		0x0	R

## Register (0x0D) DATA\_9

DESCRIPTION: ACC\_X(MSB)

RESET: 0x00

DEFINITION (Go to [register map](#)):

Address	Bit	Name	Description	Reset	Access
0x0D		DATA_9		0x00	
	7...0	acc_x_15_8		0x0	R



**Register (0x0E) DATA\_10**

DESCRIPTION: ACC\_Y(LSB)

RESET: 0x00

DEFINITION (Go to [register map](#)):

Address	Bit	Name	Description	Reset	Access
0x0E		DATA_10		0x00	
	7...0	acc_y_7_0		0x0	R

**Register (0x0F) DATA\_11**

DESCRIPTION: ACC\_Y(MSB)

RESET: 0x00

DEFINITION (Go to [register map](#)):

Address	Bit	Name	Description	Reset	Access
0x0F		DATA_11		0x00	
	7...0	acc_y_15_8		0x0	R

**Register (0x10) DATA\_12**

DESCRIPTION: ACC\_Z(LSB)

RESET: 0x00

DEFINITION (Go to [register map](#)):

Address	Bit	Name	Description	Reset	Access
0x10		DATA_12		0x00	
	7...0	acc_z_7_0		0x0	R

**Register (0x11) DATA\_13**

DESCRIPTION: ACC\_Z(MSB)

RESET: 0x00

DEFINITION (Go to [register map](#)):

Address	Bit	Name	Description	Reset	Access
0x11		DATA_13		0x00	
	7...0	acc_z_15_8		0x0	R

## Register (0x12) DATA\_14

DESCRIPTION: GYR\_X(LSB)

RESET: 0x00

DEFINITION (Go to [register map](#)):

Address	Bit	Name	Description	Reset	Access
0x12		DATA_14		0x00	
	7...0	gyr_x_7_0		0x0	R

## Register (0x13) DATA\_15

DESCRIPTION: GYR\_X(MSB)

RESET: 0x00

DEFINITION (Go to [register map](#)):

Address	Bit	Name	Description	Reset	Access
0x13		DATA_15		0x00	
	7...0	gyr_x_15_8		0x0	R

## Register (0x14) DATA\_16

DESCRIPTION: GYR\_Y(LSB)

RESET: 0x00

DEFINITION (Go to [register map](#)):

Address	Bit	Name	Description	Reset	Access
0x14		DATA_16		0x00	
	7...0	gyr_y_7_0		0x0	R

## Register (0x15) DATA\_17

DESCRIPTION: GYR\_Y(MSB)

RESET: 0x00

DEFINITION (Go to [register map](#)):

Address	Bit	Name	Description	Reset	Access
0x15		DATA_17		0x00	
	7...0	gyr_y_15_8		0x0	R

## Register (0x16) DATA\_18

DESCRIPTION: GYR\_Z(LSB)

RESET: 0x00

DEFINITION (Go to [register map](#)):

Address	Bit	Name	Description	Reset	Access
0x16		DATA_18		0x00	
	7...0	gyr_z_7_0		0x0	R

## Register (0x17) DATA\_19

DESCRIPTION: GYR\_Z(MSB)

RESET: 0x00

DEFINITION (Go to [register map](#)):

Address	Bit	Name	Description	Reset	Access
0x17		DATA_19		0x00	
	7...0	gyr_z_15_8		0x0	R

## Register (0x18) SENSORTIME\_0

DESCRIPTION: Sensor time &lt;7:0&gt;

RESET: 0x00

DEFINITION (Go to [register map](#)):

Address	Bit	Name	Description	Reset	Access
0x18		SENSORTIME_0		0x00	
	7...0	sensor_time_7_0	Sensor time <7:0>	0x0	R

## Register (0x19) SENSORTIME\_1

DESCRIPTION: Sensor time &lt;15:8&gt;

RESET: 0x00

DEFINITION (Go to [register map](#)):

Address	Bit	Name	Description	Reset	Access
0x19		SENSORTIME_1		0x00	
	7...0	sensor_time_15_8	Sensor time <15:8>.	0x0	R

## Register (0x1A) SENSORTIME\_2

DESCRIPTION: Sensor time &lt;23:16&gt;

RESET: 0x00

DEFINITION (Go to [register map](#)):

Address	Bit	Name	Description	Reset	Access
0x1A		SENSORTIME_2		0x00	
	7...0	sensor_time_23_16	Sensor time <23:16> The sensor time is a 24 bit counter available in suspend, low power, and normal mode. The value of the SENSORTIME register is shadowed, when it is read in a burst read with the data register at the beginning of the operation and the shadowed value is returned. When the fifo is read the register is shadowed, whenever a new frame is read. The resolution of the sensor_time is 39.0625 us, and it is synchronous to ODR. The register wraps if it reaches 0xFFFFFFFF.	0x0	R

## Register (0x1B) EVENT

DESCRIPTION: Sensor event flags. Will be cleared on read when bit 0 is sent out over the bus.

RESET: 0x01

DEFINITION (Go to [register map](#)):

Address	Bit	Name	Description	Reset	Access															
0x1B		EVENT		0x01																
	0	por_detected	'1' after device power up or softreset, '0' after status read.	0x1	R															
	4...2	error_code	Error codes for persistent errors <table border="1"> <thead> <tr> <th>Value</th> <th>Name</th> <th>Description</th> </tr> </thead> <tbody> <tr> <td>0x00</td> <td>no_error</td> <td>no error is reported</td> </tr> <tr> <td>0x01</td> <td>acc_err</td> <td>error in Register ACC_CONF</td> </tr> <tr> <td>0x02</td> <td>gyr_err</td> <td>error in Register GYR_CONF</td> </tr> <tr> <td>0x03</td> <td>acc_and_gyr_err</td> <td>error in Registers ACC_GYR &amp; GYR_CONF</td> </tr> </tbody> </table>	Value	Name	Description	0x00	no_error	no error is reported	0x01	acc_err	error in Register ACC_CONF	0x02	gyr_err	error in Register GYR_CONF	0x03	acc_and_gyr_err	error in Registers ACC_GYR & GYR_CONF	0x0	R
Value	Name	Description																		
0x00	no_error	no error is reported																		
0x01	acc_err	error in Register ACC_CONF																		
0x02	gyr_err	error in Register GYR_CONF																		
0x03	acc_and_gyr_err	error in Registers ACC_GYR & GYR_CONF																		

### Register (0x1C) INT\_STATUS\_0

DESCRIPTION: Interrupt/Feature Status. Will be cleared on read.

RESET: 0x00

DEFINITION (Go to [register map](#)):

Address	Bit	Name	Description	Reset	Access
0x1C		INT_STATUS_0		0x00	
	0	sig_motion_out	Sigmotion output.	0x0	R
	1	step_counter_out	Step-counter watermark or Step-detector output	0x0	R
	2	activity_out	Step activity output	0x0	R
	3	wrist_wear_wakeup_out	Wrist wear wakeup output	0x0	R
	4	wrist_gesture_out	Wrist gesture output	0x0	R
	5	no_motion_out	No motion detection output	0x0	R
	6	any_motion_out	Any motion detection output	0x0	R
	7	reserved	Reserved	0x0	R

### Register (0x1D) INT\_STATUS\_1

DESCRIPTION: Interrupt Status 1. Will be cleared on read when bit 0 is sent out over the bus.

RESET: 0x00

DEFINITION (Go to [register map](#)):

Address	Bit	Name	Description	Reset	Access
0x1D		INT_STATUS_1		0x00	
	0	ffull_int	FIFO Full Interrupt	0x0	R
	1	fwm_int	FIFO Watermark Interrupt	0x0	R
	2	err_int	ERROR Interrupt	0x0	R
	5	aux_drdy_int	Auxiliary Data Ready Interrupt	0x0	R
	6	gyr_drdy_int	Gyroscope Data Ready Interrupt	0x0	R
	7	acc_drdy_int	Accelerometer Data Ready Interrupt	0x0	R

### Register (0x1E) SC\_OUT\_0

DESCRIPTION: Step counting value byte-0

RESET: 0x00

DEFINITION (Go to [register map](#)):

Address	Bit	Name	Description	Reset	Access
0x1E		SC_OUT_0		0x00	
	7..0	byte_0	Step counting value byte-0 (least significant byte)	0x0	R

## Register (0x1F) SC\_OUT\_1

DESCRIPTION: Step counting value byte-1

RESET: 0x00

DEFINITION (Go to [register map](#)):

Address	Bit	Name	Description	Reset	Access
0x1F		SC_OUT_1		0x00	
	7...0	byte_1	Step counting value byte-1	0x0	R

## Register (0x20) WR\_GEST\_ACT

DESCRIPTION: Wrist gesture and activity detection output

RESET: 0x00

DEFINITION (Go to [register map](#)):

Address	Bit	Name	Description	Reset	Access																				
0x20		WR_GEST_ACT		0x00																					
	2...0	wr_gest_out	Output value of the wrist gesture detection feature. Value after device initialization is 0b00 i.e. unknown gesture <table border="1"> <thead> <tr> <th>Value</th> <th>Name</th> <th>Description</th> </tr> </thead> <tbody> <tr> <td>0x00</td> <td>unknown_gesture</td> <td>Unknown gesture</td> </tr> <tr> <td>0x01</td> <td>push_arm_down</td> <td>Push arm down gesture</td> </tr> <tr> <td>0x02</td> <td>pivot_up</td> <td>Pivot up gesture</td> </tr> <tr> <td>0x03</td> <td>wrist_shake_jiggle</td> <td>Wrist shake/jiggle gesture</td> </tr> <tr> <td>0x04</td> <td>flick_in</td> <td>Arm flick in gesture</td> </tr> <tr> <td>0x05</td> <td>flick_out</td> <td>Arm flick out gesture</td> </tr> </tbody> </table>	Value	Name	Description	0x00	unknown_gesture	Unknown gesture	0x01	push_arm_down	Push arm down gesture	0x02	pivot_up	Pivot up gesture	0x03	wrist_shake_jiggle	Wrist shake/jiggle gesture	0x04	flick_in	Arm flick in gesture	0x05	flick_out	Arm flick out gesture	0x0
Value	Name	Description																							
0x00	unknown_gesture	Unknown gesture																							
0x01	push_arm_down	Push arm down gesture																							
0x02	pivot_up	Pivot up gesture																							
0x03	wrist_shake_jiggle	Wrist shake/jiggle gesture																							
0x04	flick_in	Arm flick in gesture																							
0x05	flick_out	Arm flick out gesture																							
	4...3	act_out	Output value of the activity detection feature. Value after device initialization is 0b11 i.e. unknown activity <table border="1"> <thead> <tr> <th>Value</th> <th>Name</th> <th>Description</th> </tr> </thead> <tbody> <tr> <td>0x00</td> <td>still</td> <td>User stationary</td> </tr> <tr> <td>0x01</td> <td>walking</td> <td>User walking</td> </tr> <tr> <td>0x02</td> <td>running</td> <td>User running</td> </tr> <tr> <td>0x03</td> <td>unknown</td> <td>Unknown state</td> </tr> </tbody> </table>	Value	Name	Description	0x00	still	User stationary	0x01	walking	User walking	0x02	running	User running	0x03	unknown	Unknown state	0x0	R					
Value	Name	Description																							
0x00	still	User stationary																							
0x01	walking	User walking																							
0x02	running	User running																							
0x03	unknown	Unknown state																							

## Register (0x21) INTERNAL\_STATUS

DESCRIPTION: Error bits and message indicating internal status

RESET: 0x00

DEFINITION (Go to [register map](#)):

Address	Bit	Name	Description	Reset	Access																											
0x21		INTERNAL_STATUS		0x00																												
	3...0	message	Internal Status Message <table border="1"> <thead> <tr> <th>Value</th> <th>Name</th> <th>Description</th> </tr> </thead> <tbody> <tr> <td>0x00</td> <td>not_init</td> <td>ASIC is not initialized</td> </tr> <tr> <td>0x01</td> <td>init_ok</td> <td>ASIC initialized</td> </tr> <tr> <td>0x02</td> <td>init_err</td> <td>Initialization error</td> </tr> <tr> <td>0x03</td> <td>drv_err</td> <td>Invalid driver</td> </tr> <tr> <td>0x04</td> <td>sns_stop</td> <td>Sensor stopped</td> </tr> <tr> <td>0x05</td> <td>nvm_error</td> <td>Internal error while accessing NVM</td> </tr> <tr> <td>0x06</td> <td>start_up_error</td> <td>Internal error while accessing NVM and Initialization error</td> </tr> <tr> <td>0x07</td> <td>compat_error</td> <td>Compatibility error</td> </tr> </tbody> </table>	Value	Name	Description	0x00	not_init	ASIC is not initialized	0x01	init_ok	ASIC initialized	0x02	init_err	Initialization error	0x03	drv_err	Invalid driver	0x04	sns_stop	Sensor stopped	0x05	nvm_error	Internal error while accessing NVM	0x06	start_up_error	Internal error while accessing NVM and Initialization error	0x07	compat_error	Compatibility error	0x0	R
Value	Name	Description																														
0x00	not_init	ASIC is not initialized																														
0x01	init_ok	ASIC initialized																														
0x02	init_err	Initialization error																														
0x03	drv_err	Invalid driver																														
0x04	sns_stop	Sensor stopped																														
0x05	nvm_error	Internal error while accessing NVM																														
0x06	start_up_error	Internal error while accessing NVM and Initialization error																														
0x07	compat_error	Compatibility error																														
	4	Reserved	Reserved	0x0	R																											
	5	axes_remap_error	Incorrect axes remapping. X,Y,Z axes must be mapped to exclusively separate axes i.e. they cannot be mapped to same axes.	0x0	R																											
	6	odr_50hz_error	The minimum bandwidth conditions are not respected for the features which require 50 Hz data.	0x0	R																											
	7	Reserved	Reserved	0x0	R																											

### Register (0x22) TEMPERATURE\_0

DESCRIPTION: Temperature LSB; The temperature is disabled when all sensors are in suspend. The output word of the 16-bit temperature sensor is valid if the Gyroscope is in normal mode, i.e. `gyr_pmu_status=1`. The resolution is  $1/2^9$  K/LSB. The absolute accuracy of the temperature is in the order of:

0x7FFF ->  $87-1/2^9$  °C  
 0x0000 -> 23°C  
 0x8001 ->  $-41+1/2^9$  °C  
 0x8000 -> invalid

If the Gyroscope is in normal mode (see register `PMU_STATUS`), the temperature is updated every 10 ms (+-12%), if the gyroscope is in standby mode or fast-power up mode, the temperature is updated ever 1.28 s aligned with bit 15 of the register `SENSORTIME`.

RESET: 0x00

DEFINITION (Go to [register map](#)):

Address	Bit	Name	Description	Reset	Access
0x22		TEMPERATURE_0		0x00	
	7...0	tmp_data_7_0	Temperature value.	0x0	R

### Register (0x23) TEMPERATURE\_1

DESCRIPTION: Contains the MSBs of temperature sensor value

RESET: 0x80

DEFINITION (Go to [register map](#)):

Address	Bit	Name	Description	Reset	Access
0x23		TEMPERATURE_1		0x80	
	7...0	tmp_data_15_8	Temperature LSBs.	0x80	R

### Register (0x24) FIFO\_LENGTH\_0

DESCRIPTION: FIFO byte count register (LSB)

RESET: 0x00

DEFINITION (Go to [register map](#)):

Address	Bit	Name	Description	Reset	Access
0x24		FIFO_LENGTH_0		0x00	
	7...0	fifo_byte_counter_7_0	Current fill level of FIFO buffer This includes the skip frame for a full fifo. An empty FIFO corresponds to 0x000. The byte counter may be reset by reading out all frames from the FIFO buffer or when the FIFO is reset through the register CMD. The byte counter is updated each time a complete frame was read or written.	0x0	R



### Register (0x25) FIFO\_LENGTH\_1

DESCRIPTION: FIFO byte count register (MSB)

RESET: 0x00

DEFINITION (Go to [register map](#)):

Address	Bit	Name	Description	Reset	Access
0x25		FIFO_LENGTH_1		0x00	
	5..0	fifo_byte_counter_13_8	FIFO byte counter bits 13..8	0x0	R

### Register (0x26) FIFO\_DATA

DESCRIPTION: FIFO data output register

RESET: 0x00

DEFINITION (Go to [register map](#)):

Address	Bit	Name	Description	Reset	Access
0x26		FIFO_DATA		0x00	
	7..0	fifo_data	FIFO read data (8 bits) Data format depends on the setting of register FIFO_CONFIG. The FIFO data are organized in frames. The new data flag is preserved. Read burst access must be used, the address will not increment when the read burst reads at the address of FIFO_DATA. When a frame is only partially read out it is retransmitted including the header at the next readout.	0x0	R

### Register (0x2F) FEAT\_PAGE

DESCRIPTION: Page number for feature configuration and output registers

RESET: 0x00

DEFINITION (Go to [register map](#)):

Address	Bit	Name	Description	Reset	Access
0x2F		FEAT_PAGE		0x00	
	2..0	page	Map 16 feature registers to one of the 8 feature pages	0x0	RW

## Register (0x30) FEATURES[16]

DESCRIPTION: Input registers for feature configuration. Output registers for feature results.

RESET: 0x00

DEFINITION (Go to [register map](#)):

Page 0

Address	Bit	Name	Description	Reset	Access
step_counter_output					
0x30		SC_OUT_0_1	Describes lower word of step counter	0x0000	
	7...0	byte_0	Value of step counter byte 0	0x0	R
	15...8	byte_1	Value of step counter byte 1	0x0	R
0x32		SC_OUT_2_3	Describes higher word of step counter	0x0000	
	7...0	byte_2	Value of step counter byte 2	0x0	R
	15...8	byte_3	Value of step counter byte 3	0x0	R
activity_output					
0x34		ACT_OUT	Describes activity output	0x0000	
	1...0	act_out	Output value of the activity detection feature. Value after device initialization is 0b11 i.e. unknown activity <b>Value Name Description</b> 0x00 still User stationary 0x01 walking User walking 0x02 running User running 0x03 unknown Unknown state	0x0	R
wrist_gesture_output					
0x36		WR_GEST_OUT	Describes wrist gesture output	0x0000	
	2...0	wr_gest_out	Output value of the wrist gesture detection feature. Value after device initialization is 0b00 i.e. unknown gesture <b>Value Name Description</b> 0x00 unknown_gesture Unknown gesture 0x01 push_arm_down Push arms down gesture 0x02 pivot_up Pivot up gesture 0x03 wrist_shake_jiggle Wrist shake/jiggle gesture 0x04 flick_in Arm flick in gesture 0x05 flick_out Arm flick out gesture	0x0	R

gyr_gain_status																				
0x38		GYR_GAIN_STATUS	Describes the saturation status for the gyroscope gain update and G_TRIGGER command status	0x0000																
	0	sat_x	This bit will be 1 if the updated gain results to saturated value based on the ratio provided for x axis, otherwise it will be 0	0x0	R															
	1	sat_y	This bit will be 1 if the updated gain results to saturated value based on the ratio provided for y axis, otherwise it will be 0	0x0	R															
	2	sat_z	This bit will be 1 if the updated gain results to saturated value based on the ratio provided for z axis, otherwise it will be 0	0x0	R															
	5...3	g_trig_status	<p>Status of gyroscope trigger G_TRIGGER command. These bits are updated at the end of feature execution.</p> <table border="1"> <thead> <tr> <th>Value</th> <th>Name</th> <th>Description</th> </tr> </thead> <tbody> <tr> <td>0x00</td> <td>no_err</td> <td>Command is valid. Selected feature has been executed and output of feature has been updated.</td> </tr> <tr> <td>0x01</td> <td>precon_err</td> <td>Command is aborted. Pre-condition to start the feature was not completed.</td> </tr> <tr> <td>0x02</td> <td>dl_err</td> <td>Command is aborted. Unsuccessful download of 2kB configuration stream.</td> </tr> <tr> <td>0x03</td> <td>abort_err</td> <td>Command is aborted either by host via the block bit or due to motion detection.</td> </tr> </tbody> </table>	Value	Name	Description	0x00	no_err	Command is valid. Selected feature has been executed and output of feature has been updated.	0x01	precon_err	Command is aborted. Pre-condition to start the feature was not completed.	0x02	dl_err	Command is aborted. Unsuccessful download of 2kB configuration stream.	0x03	abort_err	Command is aborted either by host via the block bit or due to motion detection.	0x0	R
Value	Name	Description																		
0x00	no_err	Command is valid. Selected feature has been executed and output of feature has been updated.																		
0x01	precon_err	Command is aborted. Pre-condition to start the feature was not completed.																		
0x02	dl_err	Command is aborted. Unsuccessful download of 2kB configuration stream.																		
0x03	abort_err	Command is aborted either by host via the block bit or due to motion detection.																		
Reserved																				
0x3A		Reserved	Reserved	0x0000																
	15...0	Reserved	Reserved	0x0	R															
gyr_postproc																				
0x3C		GYR_CAS	Register for gyroscope data post processing	0x0000																

	6...0	factor_zx	Factor to further optimize the gyroscope performance	0x0	R
Reserved					
0x3E		Reserved	Reserved	0x0000	
	8	Reserved	Reserved	0x0	R
	9	Reserved	Reserved	0x0	R
	10	Reserved	Reserved	0x0	R
	11	Reserved	Reserved	0x0	R
	12	Reserved	Reserved	0x0	R
	13	Reserved	Reserved	0x0	R
	14	Reserved	Reserved	0x0	R
	15	Reserved	Reserved	0x0	R

## Page 1

Address	Bit	Name	Description	Reset	Access									
general_settings														
0x30		Reserved	Reserved	0x0000										
	15...0	Reserved	Reserved	0x0	R									
0x32		G_TRIGGER_1	Configuration for features triggered by G_TRIGGER command.	0x0000										
	7...0	max_burst_len	Maximum burst-write length in 16-bits words to download 2kB configuration stream of G_TRIGGER feature. Range is 0 to 255. E.g. value = 20 means that maximum burst-write length is set to 20 words or 40 bytes.	0x0	RW									
	8	select	Select feature that should be executed <table border="1"> <thead> <tr> <th>Value</th> <th>Name</th> <th>Description</th> </tr> </thead> <tbody> <tr> <td>0x00</td> <td>gyr_bist</td> <td>Gyroscope built-in self-test will be executed</td> </tr> <tr> <td>0x01</td> <td>crt</td> <td>CRT will be executed</td> </tr> </tbody> </table>	Value	Name	Description	0x00	gyr_bist	Gyroscope built-in self-test will be executed	0x01	crt	CRT will be executed	0x0	RW
Value	Name	Description												
0x00	gyr_bist	Gyroscope built-in self-test will be executed												
0x01	crt	CRT will be executed												
	9	block	Block feature with next G_TRIGGER command <table border="1"> <thead> <tr> <th>Value</th> <th>Name</th> <th>Description</th> </tr> </thead> <tbody> <tr> <td>0x00</td> <td>unblock</td> <td>Do not block further G_TRIGGER commands</td> </tr> <tr> <td>0x01</td> <td>block</td> <td>With the next G_TRIGGER command, the ongoing selected feature will be aborted OR if a</td> </tr> </tbody> </table>	Value	Name	Description	0x00	unblock	Do not block further G_TRIGGER commands	0x01	block	With the next G_TRIGGER command, the ongoing selected feature will be aborted OR if a	0x0	RW
Value	Name	Description												
0x00	unblock	Do not block further G_TRIGGER commands												
0x01	block	With the next G_TRIGGER command, the ongoing selected feature will be aborted OR if a												

			feature is not ongoing then the G_TRIGGER command will be ignored		
0x34		GEN_SET_1	Describes configuration of general features	0x0088	
	1...0	map_x_axis	Map the x axis to desired axis <b>Value</b> <b>Name</b> <b>Description</b> 0x00 x_axis Map to x-axis 0x01 y_axis Map to y-axis 0x02 z_axis Map to z-axis 0x03 reserved Map to x-axis	0x0	RW
	2	map_x_axis_sign	Map the x axis sign to the desired one. <b>Value</b> <b>Name</b> <b>Description</b> 0x00 not_invert Clear this bit to not invert the x axis  0x01 invert Set this bit to invert the x axis	0x0	RW
	4...3	map_y_axis	Map the y axis to desired axis <b>Value</b> <b>Name</b> <b>Description</b> 0x00 x_axis Map to x-axis 0x01 y_axis Map to y-axis 0x02 z_axis Map to z-axis 0x03 reserved Map to y-axis	0x1	RW
	5	map_y_axis_sign	Map the y axis sign to the desired one <b>Value</b> <b>Name</b> <b>Description</b> 0x00 not_invert Clear this bit to not invert the y axis  0x01 invert Set this bit to invert the y axis	0x0	RW
	7...6	map_z_axis	Map the z axis to desired axis <b>Value</b> <b>Name</b> <b>Description</b> 0x00 x_axis Map to x-axis 0x01 y_axis Map to y-axis 0x02 z_axis Map to z-axis 0x03 reserved Map to z-axis	0x2	RW
	8	map_z_axis_sign	Map the z axis sign to the desired one <b>Value</b> <b>Name</b> <b>Description</b> 0x00 not_invert Clear this bit to not invert the z axis  0x01 invert Set this bit to invert the z axis	0x0	RW
	9	gyr_self_off	Describes the self offset correction behavior <b>Value</b> <b>Name</b> <b>Description</b>	0x0	RW

			0x00    disable    Disable self offset correction. Host should update the gyroscope offset register.  0x01    enable    Enable self offset correction. Gyroscope offset register will be updated by the device. Host should not update the gyroscope offset registers.		
	10	nvm_prog_prep	Prepares the system for NVM programming	0x0	RW
<b>gyr_gain_update</b>					
0x36		GYR_GAIN_UPD_1	$\omega_{rx}/\omega_{mx}$ for which the gain needs to be updated.	0x0000	
	10...0	ratio_x	gain update value for x-axis. Fixed point representation is Q(1,10) with range from $1\pm 0.25$ . For example, value of 0.75 shall be represented in 11bits as 0x300 and 1.25 shall be represented in 11bits as 0x500	0x0	RW
0x38		GYR_GAIN_UPD_2	$\omega_{ry}/\omega_{my}$ for which the gain needs to be updated.	0x0000	
	10...0	ratio_y	gain update value for y-axis. Fixed point representation is Q(1,10) with range from $1\pm 0.25$ . For example, value of 0.75 shall be represented in 11bits as 0x300 and 1.25 shall be represented in 11bits as 0x500	0x0	RW
0x3A		GYR_GAIN_UPD_3	$\omega_{rz}/\omega_{mz}$ for which the gain needs to be updated.	0x0000	
	10...0	ratio_z	gain update value for z-axis. Fixed point representation is Q(1,10) with range from $1\pm 0.25$ . For example, value of 0.75 shall be represented in 11bits as 0x300 and 1.25 shall be represented in 11bits as 0x500	0x0	RW
	11	enable	Enable the gyroscope gain update by writing a value 1 to it. Once the gain update is completed, the device will clear the bit.	0x0	RW
<b>any_motion</b>					
0x3C		ANYMO_1	Any-motion detection general configuration flags - part 1	0xE005	

	12...0	duration	Defines the number of consecutive data points for which the threshold condition must be respected, for interrupt assertion. It is expressed in 50 Hz samples (20 ms). Range is 0 to 163sec. Default value is 5=100ms.	0x5	RW
	13	select_x	Selects the feature on a per-axis basis	0x1	RW
	14	select_y	Selects the feature on a per-axis basis	0x1	RW
	15	select_z	Selects the feature on a per-axis basis	0x1	RW
0x3E		ANYMO_2	Any-motion detection general configuration flags - part 2	0x38AA	
	10...0	threshold	Slope threshold value for any-motion detection. Range is 0 to 1g. Default value is 0xAA = 83mg.	0xAA	RW
	14...11	out_conf	Enable bits for enabling output into the register status bits and, if desired, onto the interrupt pin <b>Value Name Description</b> 0x00 disable Output of feature not assigned to any interrupt bits 0..7 of INT_STATUS_0 and INT1/2_MAP_FEAT 0x01 BIT_0 Output assigned to bit-0 0x02 BIT_1 Output assigned to bit-1 0x03 BIT_2 Output assigned to bit-2 0x04 BIT_3 Output assigned to bit-3 0x05 BIT_4 Output assigned to bit-4 0x06 BIT_5 Output assigned to bit-5 0x07 BIT_6 Output assigned to bit-6 0x08 BIT_7 Output assigned to bit-7	0x7	RW
	15	enable	Enables the feature	0x0	RW

Page 2

Address	Bit	Name	Description	Reset	Access	
no_motion						
0x30		NOMO_1	No-motion detection general configuration flags - part 1	0xE005		
	12...0	duration	Defines the number of consecutive data points for which the threshold condition must be respected, for interrupt assertion. It is expressed in 50 Hz samples (20 ms). Range is 0 to 163sec. Default value is 5=100ms.	0x5	RW	
	13	select_x	Selects the feature on a per-axis basis	0x1	RW	
	14	select_y	Selects the feature on a per-axis basis	0x1	RW	
	15	select_z	Selects the feature on a per-axis basis	0x1	RW	
0x32		NOMO_2	No-motion detection general configuration flags - part 2	0x3090		
	10...0	threshold	Slope threshold value for no-motion detection. Range is 0 to 1g. Default value is 0x90 = 70mg.	0x90	RW	
	14...11	out_conf	Enable bits for enabling output into the register status bits and, if desired, onto the interrupt pin <b>Value Name Description</b> 0x00 disable Output of feature not assigned to any interrupt bits 0..7 of INT_STATUS_0 and INT1/2_MAP_FEAT 0x01 BIT_0 Output assigned to bit-0 0x02 BIT_1 Output assigned to bit-1 0x03 BIT_2 Output assigned to bit-2 0x04 BIT_3 Output assigned to bit-3 0x05 BIT_4 Output assigned to bit-4 0x06 BIT_5 Output assigned to bit-5 0x07 BIT_6 Output assigned to bit-6 0x08 BIT_7 Output assigned to bit-7	0x6	RW	
	15	enable	Enables the feature	0x0	RW	
sig_motion						
0x34		SIGMO_1	Block size	0x00FA		
	15...0	block_size	Defines the duration after which the significant motion interrupt is triggered. It is expressed in 50 Hz samples (20 ms). Default value is 0xFA=5sec.	0xFA	RW	
0x36		Reserved	Reserved	0x0096		
	15...0	Reserved	Reserved	0x96	RW	



0x38		Reserved	Reserved	0x094B																														
	15...0	Reserved	Reserved	0x94B	RW																													
0x3A		Reserved	Reserved	0x0011																														
	15...0	Reserved	Reserved	0x11	RW																													
0x3C		Reserved	Reserved	0x0011																														
	15...0	Reserved	Reserved	0x11	RW																													
0x3E		SIGMO_2	Significant motion setting	0x0002																														
	0	enable	Enables the feature	0x0	RW																													
	4...1	out_conf	Enable bits for enabling output into the register status bits and, if desired, onto the interrupt pin  <table border="1"> <thead> <tr> <th>Value</th> <th>Name</th> <th>Description</th> </tr> </thead> <tbody> <tr> <td>0x00</td> <td>disable</td> <td>Output of feature not assigned to any interrupt bits 0..7 of INT_STATUS_0 and INT1/2_MAP_FEAT</td> </tr> <tr> <td>0x01</td> <td>BIT_0</td> <td>Output assigned to bit-0</td> </tr> <tr> <td>0x02</td> <td>BIT_1</td> <td>Output assigned to bit-1</td> </tr> <tr> <td>0x03</td> <td>BIT_2</td> <td>Output assigned to bit-2</td> </tr> <tr> <td>0x04</td> <td>BIT_3</td> <td>Output assigned to bit-3</td> </tr> <tr> <td>0x05</td> <td>BIT_4</td> <td>Output assigned to bit-4</td> </tr> <tr> <td>0x06</td> <td>BIT_5</td> <td>Output assigned to bit-5</td> </tr> <tr> <td>0x07</td> <td>BIT_6</td> <td>Output assigned to bit-6</td> </tr> <tr> <td>0x08</td> <td>BIT_7</td> <td>Output assigned to bit-7</td> </tr> </tbody> </table>	Value	Name	Description	0x00	disable	Output of feature not assigned to any interrupt bits 0..7 of INT_STATUS_0 and INT1/2_MAP_FEAT	0x01	BIT_0	Output assigned to bit-0	0x02	BIT_1	Output assigned to bit-1	0x03	BIT_2	Output assigned to bit-2	0x04	BIT_3	Output assigned to bit-3	0x05	BIT_4	Output assigned to bit-4	0x06	BIT_5	Output assigned to bit-5	0x07	BIT_6	Output assigned to bit-6	0x08	BIT_7	Output assigned to bit-7	0x1
Value	Name	Description																																
0x00	disable	Output of feature not assigned to any interrupt bits 0..7 of INT_STATUS_0 and INT1/2_MAP_FEAT																																
0x01	BIT_0	Output assigned to bit-0																																
0x02	BIT_1	Output assigned to bit-1																																
0x03	BIT_2	Output assigned to bit-2																																
0x04	BIT_3	Output assigned to bit-3																																
0x05	BIT_4	Output assigned to bit-4																																
0x06	BIT_5	Output assigned to bit-5																																
0x07	BIT_6	Output assigned to bit-6																																
0x08	BIT_7	Output assigned to bit-7																																

Page 3

Address	Bit	Name	Description	Reset	Access
step_counter_1					
0x30		SC_1	Step Counter setting	0x012D	
	15...0	param_1	Step Counter param 1	0x12D	RW
0x32		SC_2	Step Counter setting	0x7BD4	
	15...0	param_2	Step Counter param 2	0x7BD4	RW
0x34		SC_3	Step Counter setting	0x013B	
	15...0	param_3	Step Counter param 3	0x13B	RW
0x36		SC_4	Step Counter setting	0x7ADB	
	15...0	param_4	Step Counter param 4	0x7ADB	RW
0x38		SC_5	Step Counter setting	0x0004	
	15...0	param_5	Step Counter param 5	0x4	RW
0x3A		SC_6	Step Counter setting	0x7B3F	
	15...0	param_6	Step Counter param 6	0x7B3F	RW
0x3C		SC_7	Step Counter setting	0x6CCD	
	15...0	param_7	Step Counter param 7	0x6CCD	RW
0x3E		SC_8	Step Counter setting	0x04C3	
	15...0	param_8	Step Counter param 8	0x4C3	RW

Page 4

Address	Bit	Name	Description	Reset	Access
step_counter_2					
0x30		SC_9	Step Counter setting	0x0985	
	15...0	param_9	Step Counter param 9	0x985	RW
0x32		SC_10	Step Counter setting	0x04C3	
	15...0	param_10	Step Counter param 10	0x4C3	RW
0x34		SC_11	Step Counter setting	0xE6EC	
	15...0	param_11	Step Counter param 11	0xE6EC	RW
0x36		SC_12	Step Counter setting	0x460C	
	15...0	param_12	Step Counter param 12	0x460C	RW
0x38		SC_13	Step Counter setting	0x0001	
	15...0	param_13	Step Counter param 13	0x1	RW
0x3A		SC_14	Step Counter setting	0x0027	
	15...0	param_14	Step Counter param 14	0x27	RW
0x3C		SC_15	Step Counter setting	0x0019	
	15...0	param_15	Step Counter param 15	0x19	RW
0x3E		SC_16	Step Counter setting	0x0096	
	15...0	param_16	Step Counter param 16	0x96	RW

Page 5

Address	Bit	Name	Description	Reset	Access
step_counter_3					
0x30		SC_17	Step Counter setting	0x00A0	
	15...0	param_17	Step Counter param 17	0xA0	RW
0x32		SC_18	Step Counter setting	0x0001	
	15...0	param_18	Step Counter param 18	0x1	RW
0x34		SC_19	Step Counter setting	0x000C	
	15...0	param_19	Step Counter param 19	0xC	RW
0x36		SC_20	Step Counter setting	0x3CF0	
	15...0	param_20	Step Counter param 20	0x3CF0	RW
0x38		SC_21	Step Counter setting	0x0100	
	15...0	param_21	Step Counter param 21	0x100	RW
0x3A		SC_22	Step Counter setting	0x0001	
	15...0	param_22	Step Counter param 22	0x1	RW
0x3C		SC_23	Step Counter setting	0x0003	
	15...0	param_23	Step Counter param 23	0x3	RW
0x3E		SC_24	Step Counter setting	0x0001	
	15...0	param_24	Step Counter param 24	0x1	RW

Page 6

Address	Bit	Name	Description	Reset	Access																													
step_counter_4																																		
0x30		SC_25	Step Counter setting	0x000E																														
	15...0	param_25	Step Counter param 25	0xE	RW																													
0x32		SC_26	Step Counter and Step Detector Settings	0x0000																														
	9...0	watermark_level	Watermark level; the Step-counter will trigger output every time this number of steps are counted. Holds implicitly a 20x factor, so the range is 0 to 20460, with resolution of 20 steps. If 0, the output is disabled.	0x0	RW																													
	10	reset_counter	Step count value can be reset only when any one of features mentioned in this register is enabled.	0x0	RW																													
	11	en_detector	Enables the Step Detector.	0x0	RW																													
	12	en_counter	Enables the Step Counter.	0x0	RW																													
	13	en_activity	Enables the activity detection(Running, Walking, Stationary, Unknown)	0x0	RW																													
0x34		SC_27	Step Counter and Step Detector Settings	0x0032																														
	3...0	out_conf_step_detector	<p>Enable bits for enabling output into the register status bits and, if desired, onto the interrupt pin</p> <table border="1"> <thead> <tr> <th>Value</th> <th>Name</th> <th>Description</th> </tr> </thead> <tbody> <tr> <td>0x00</td> <td>disable</td> <td>Output of feature not assigned to any interrupt bits 0..7 of INT_STATUS_0 and INT1/2_MAP_FEAT</td> </tr> <tr> <td>0x01</td> <td>BIT_0</td> <td>Output assigned to bit-0</td> </tr> <tr> <td>0x02</td> <td>BIT_1</td> <td>Output assigned to bit-1</td> </tr> <tr> <td>0x03</td> <td>BIT_2</td> <td>Output assigned to bit-2</td> </tr> <tr> <td>0x04</td> <td>BIT_3</td> <td>Output assigned to bit-3</td> </tr> <tr> <td>0x05</td> <td>BIT_4</td> <td>Output assigned to bit-4</td> </tr> <tr> <td>0x06</td> <td>BIT_5</td> <td>Output assigned to bit-5</td> </tr> <tr> <td>0x07</td> <td>BIT_6</td> <td>Output assigned to bit-6</td> </tr> <tr> <td>0x08</td> <td>BIT_7</td> <td>Output assigned to bit-7</td> </tr> </tbody> </table>	Value	Name	Description	0x00	disable	Output of feature not assigned to any interrupt bits 0..7 of INT_STATUS_0 and INT1/2_MAP_FEAT	0x01	BIT_0	Output assigned to bit-0	0x02	BIT_1	Output assigned to bit-1	0x03	BIT_2	Output assigned to bit-2	0x04	BIT_3	Output assigned to bit-3	0x05	BIT_4	Output assigned to bit-4	0x06	BIT_5	Output assigned to bit-5	0x07	BIT_6	Output assigned to bit-6	0x08	BIT_7	Output assigned to bit-7	0x2
Value	Name	Description																																
0x00	disable	Output of feature not assigned to any interrupt bits 0..7 of INT_STATUS_0 and INT1/2_MAP_FEAT																																
0x01	BIT_0	Output assigned to bit-0																																
0x02	BIT_1	Output assigned to bit-1																																
0x03	BIT_2	Output assigned to bit-2																																
0x04	BIT_3	Output assigned to bit-3																																
0x05	BIT_4	Output assigned to bit-4																																
0x06	BIT_5	Output assigned to bit-5																																
0x07	BIT_6	Output assigned to bit-6																																
0x08	BIT_7	Output assigned to bit-7																																

	7...4	out_conf_activity	<p>Enable bits for enabling output into the register status bits and, if desired, onto the interrupt pin</p> <table border="1"> <thead> <tr> <th>Value</th> <th>Name</th> <th>Description</th> </tr> </thead> <tbody> <tr> <td>0x00</td> <td>disable</td> <td>Output of feature not assigned to any interrupt bits 0..7 of INT_STATUS_0 and INT1/2_MAP_FEAT</td> </tr> <tr> <td>0x01</td> <td>BIT_0</td> <td>Output assigned to bit-0</td> </tr> <tr> <td>0x02</td> <td>BIT_1</td> <td>Output assigned to bit-1</td> </tr> <tr> <td>0x03</td> <td>BIT_2</td> <td>Output assigned to bit-2</td> </tr> <tr> <td>0x04</td> <td>BIT_3</td> <td>Output assigned to bit-3</td> </tr> <tr> <td>0x05</td> <td>BIT_4</td> <td>Output assigned to bit-4</td> </tr> <tr> <td>0x06</td> <td>BIT_5</td> <td>Output assigned to bit-5</td> </tr> <tr> <td>0x07</td> <td>BIT_6</td> <td>Output assigned to bit-6</td> </tr> <tr> <td>0x08</td> <td>BIT_7</td> <td>Output assigned to bit-7</td> </tr> </tbody> </table>	Value	Name	Description	0x00	disable	Output of feature not assigned to any interrupt bits 0..7 of INT_STATUS_0 and INT1/2_MAP_FEAT	0x01	BIT_0	Output assigned to bit-0	0x02	BIT_1	Output assigned to bit-1	0x03	BIT_2	Output assigned to bit-2	0x04	BIT_3	Output assigned to bit-3	0x05	BIT_4	Output assigned to bit-4	0x06	BIT_5	Output assigned to bit-5	0x07	BIT_6	Output assigned to bit-6	0x08	BIT_7	Output assigned to bit-7	0x3	RW
Value	Name	Description																																	
0x00	disable	Output of feature not assigned to any interrupt bits 0..7 of INT_STATUS_0 and INT1/2_MAP_FEAT																																	
0x01	BIT_0	Output assigned to bit-0																																	
0x02	BIT_1	Output assigned to bit-1																																	
0x03	BIT_2	Output assigned to bit-2																																	
0x04	BIT_3	Output assigned to bit-3																																	
0x05	BIT_4	Output assigned to bit-4																																	
0x06	BIT_5	Output assigned to bit-5																																	
0x07	BIT_6	Output assigned to bit-6																																	
0x08	BIT_7	Output assigned to bit-7																																	
<b>wrist_gesture</b>																																			
0x36		WR_GEST_1	Wrist gesture configuration settings	0x0005																															
	3...0	out_conf	<p>Enable bits for enabling output into the register status bits and, if desired, onto the interrupt pin</p> <table border="1"> <thead> <tr> <th>Value</th> <th>Name</th> <th>Description</th> </tr> </thead> <tbody> <tr> <td>0x00</td> <td>disable</td> <td>Output of feature not assigned to any interrupt bits 0..7 of INT_STATUS_0 and INT1/2_MAP_FEAT</td> </tr> <tr> <td>0x01</td> <td>BIT_0</td> <td>Output assigned to bit-0</td> </tr> <tr> <td>0x02</td> <td>BIT_1</td> <td>Output assigned to bit-1</td> </tr> <tr> <td>0x03</td> <td>BIT_2</td> <td>Output assigned to bit-2</td> </tr> <tr> <td>0x04</td> <td>BIT_3</td> <td>Output assigned to bit-3</td> </tr> <tr> <td>0x05</td> <td>BIT_4</td> <td>Output assigned to bit-4</td> </tr> <tr> <td>0x06</td> <td>BIT_5</td> <td>Output assigned to bit-5</td> </tr> </tbody> </table>	Value	Name	Description	0x00	disable	Output of feature not assigned to any interrupt bits 0..7 of INT_STATUS_0 and INT1/2_MAP_FEAT	0x01	BIT_0	Output assigned to bit-0	0x02	BIT_1	Output assigned to bit-1	0x03	BIT_2	Output assigned to bit-2	0x04	BIT_3	Output assigned to bit-3	0x05	BIT_4	Output assigned to bit-4	0x06	BIT_5	Output assigned to bit-5	0x5	RW						
Value	Name	Description																																	
0x00	disable	Output of feature not assigned to any interrupt bits 0..7 of INT_STATUS_0 and INT1/2_MAP_FEAT																																	
0x01	BIT_0	Output assigned to bit-0																																	
0x02	BIT_1	Output assigned to bit-1																																	
0x03	BIT_2	Output assigned to bit-2																																	
0x04	BIT_3	Output assigned to bit-3																																	
0x05	BIT_4	Output assigned to bit-4																																	
0x06	BIT_5	Output assigned to bit-5																																	

			0x07 BIT_6 Output assigned to bit-6 0x08 BIT_7 Output assigned to bit-7		
	4	wearable_arm	Device in left (0) or right (1) arm. By default, the wearable device is assumed to be in left arm i.e. default value is 0.	0x0	RW
	5	enable	Enables the feature	0x0	RW
0x38		WR_GEST_2	Wrist gesture setting	0x06EE	
	15...0	min_flick_peak	Sine of the minimum tilt angle in portrait down direction of the device when wrist is rolled away (roll-out) from user. The configuration parameter is scaled by 2048 i.e. $2048 * \sin(\text{angle})$ . Range is 1448 to 1774. Default value is 1774.	0x6EE	RW
0x3A		WR_GEST_3	Wrist gesture setting	0x0004	
	15...0	min_flick_samples	Value of minimum time difference between wrist roll-out and roll-in movement during flick gesture. Range is 3 to 5 samples at 50Hz (i.e. 0.06 to 0.1 seconds). Default value is 4 (i.e. 0.08 seconds).	0x4	RW
0x3C		WR_GEST_4	Wrist gesture setting	0x00C8	
	15...0	max_duration	Maximum time within which gesture movement has to be completed. Range is 150 to 250 samples at 50Hz (i.e. 3 to 5 seconds). Default value is 200 (i.e. 4 seconds).	0xC8	RW
Reserved					
0x3E		Reserved	Reserved	0x0000	
	15...0	Reserved	Reserved	0x0	RW

Page 7

Address	Bit	Name	Description	Reset	Access																														
wrist_wear_wakeup																																			
0x30		WR_WAKEUP_1	Wrist wear wakeup configuration settings	0x0004																															
	3...0	out_conf	<p>Enable bits for enabling output into the register status bits and, if desired, onto the interrupt pin</p> <table border="1"> <thead> <tr> <th>Value</th> <th>Name</th> <th>Description</th> </tr> </thead> <tbody> <tr> <td>0x00</td> <td>disable</td> <td>Output of feature not assigned to any interrupt bits 0..7 of INT_STATUS_0 and INT1/2_MAP_FEATURE</td> </tr> <tr> <td>0x01</td> <td>BIT_0</td> <td>Output assigned to bit-0</td> </tr> <tr> <td>0x02</td> <td>BIT_1</td> <td>Output assigned to bit-1</td> </tr> <tr> <td>0x03</td> <td>BIT_2</td> <td>Output assigned to bit-2</td> </tr> <tr> <td>0x04</td> <td>BIT_3</td> <td>Output assigned to bit-3</td> </tr> <tr> <td>0x05</td> <td>BIT_4</td> <td>Output assigned to bit-4</td> </tr> <tr> <td>0x06</td> <td>BIT_5</td> <td>Output assigned to bit-5</td> </tr> <tr> <td>0x07</td> <td>BIT_6</td> <td>Output assigned to bit-6</td> </tr> <tr> <td>0x08</td> <td>BIT_7</td> <td>Output assigned to bit-7</td> </tr> </tbody> </table>	Value	Name	Description	0x00	disable	Output of feature not assigned to any interrupt bits 0..7 of INT_STATUS_0 and INT1/2_MAP_FEATURE	0x01	BIT_0	Output assigned to bit-0	0x02	BIT_1	Output assigned to bit-1	0x03	BIT_2	Output assigned to bit-2	0x04	BIT_3	Output assigned to bit-3	0x05	BIT_4	Output assigned to bit-4	0x06	BIT_5	Output assigned to bit-5	0x07	BIT_6	Output assigned to bit-6	0x08	BIT_7	Output assigned to bit-7	0x4	RW
Value	Name	Description																																	
0x00	disable	Output of feature not assigned to any interrupt bits 0..7 of INT_STATUS_0 and INT1/2_MAP_FEATURE																																	
0x01	BIT_0	Output assigned to bit-0																																	
0x02	BIT_1	Output assigned to bit-1																																	
0x03	BIT_2	Output assigned to bit-2																																	
0x04	BIT_3	Output assigned to bit-3																																	
0x05	BIT_4	Output assigned to bit-4																																	
0x06	BIT_5	Output assigned to bit-5																																	
0x07	BIT_6	Output assigned to bit-6																																	
0x08	BIT_7	Output assigned to bit-7																																	
	4	enable	Enables the feature	0x0	RW																														
0x32		WR_WAKEUP_2	Wrist wear wakeup setting	0x05A8																															
	15...0	min_angle_focus	Cosine of minimum expected attitude change of the device within 1 second time window when moving within focus position. The parameter is scaled by 2048 i.e. $2048 * \cos(\text{angle})$ . Range is 1024 to 1774. Default is 1448.	0x5A8	RW																														
0x34		WR_WAKEUP_3	Wrist wear wakeup setting	0x06EE																															

	15... 0	min_angle_nonfocus	Cosine of minimum expected attitude change of the device within 1 second time window when moving from non-focus to focus position. The parameter is scaled by 2048 i.e. $2048 * \cos(\text{angle})$ . Range is 1448 to 1856. Default value is 1774.	0x6EE	RW
0x36		WR_WAKEUP_4	Wrist wear wakeup setting	0x0400	
	15... 0	max_tilt_lr	Sine of the maximum allowed downward tilt angle in landscape right direction of the device, when it is in focus position (i.e. user is able to comfortably look at the dial of wear device). The configuration parameter is scaled by 2048 i.e. $2048 * \sin(\text{angle})$ . Range is 700 to 1024. Default value is 1024.	0x400	RW
0x38		WR_WAKEUP_5	Wrist wear wakeup setting	0x02BC	
	15... 0	max_tilt_ll	Sine of the maximum allowed downward tilt angle in landscape left direction of the device, when it is in focus position (i.e. user is able to comfortably look at the dial of wear device). The configuration parameter is scaled by 2048 i.e. $2048 * \sin(\text{angle})$ . Range is 700 to 1024. Default value is 700.	0x2BC	RW
0x3A		WR_WAKEUP_6	Wrist wear wakeup setting	0x00B3	
	15... 0	max_tilt_pd	Sine of the maximum allowed backward tilt angle in portrait down direction of the device, when it is in focus position (i.e. user is able to comfortably look at the dial of wear device). The configuration parameter is scaled by 2048 i.e. $2048 * \sin(\text{angle})$ . Range is 0 to 179. Default value is 179.	0xB3	RW
0x3C		WR_WAKEUP_7	Wrist wear wakeup setting	0x0785	
	15... 0	max_tilt_pu	Sine of the maximum allowed forward tilt angle in portrait up direction of the device, when it is in focus position (i.e. user is able to comfortably look at the dial of wear device). The configuration parameter is scaled by 2048 i.e. $2048 * \sin(\text{angle})$ . Range is 1774 to 1978. Default value is 1925.	0x785	RW

Reserved					
0x3E		Reserved	Reserved	0x0000	
	15...0	Reserved	Reserved	0x0	RW

## Register (0x40) ACC\_CONF

DESCRIPTION: Sets the output data rate, the bandwidth, and the read mode of the acceleration sensor

RESET: 0xA8

DEFINITION (Go to [register map](#)):

Address	Bit	Name	Description	Reset	Access																																																		
0x40		ACC_CONF		0xA8																																																			
	3...0	acc_odr	<p>ODR in Hz. The output data rate is independent of the power mode setting for the sensor</p> <table border="1"> <thead> <tr> <th>Value</th> <th>Name</th> <th>Description</th> </tr> </thead> <tbody> <tr><td>0x00</td><td>reserved</td><td>Reserved</td></tr> <tr><td>0x01</td><td>odr_0p78</td><td>25/32</td></tr> <tr><td>0x02</td><td>odr_1p5</td><td>25/16</td></tr> <tr><td>0x03</td><td>odr_3p1</td><td>25/8</td></tr> <tr><td>0x04</td><td>odr_6p25</td><td>25/4</td></tr> <tr><td>0x05</td><td>odr_12p5</td><td>25/2</td></tr> <tr><td>0x06</td><td>odr_25</td><td>25</td></tr> <tr><td>0x07</td><td>odr_50</td><td>50</td></tr> <tr><td>0x08</td><td>odr_100</td><td>100</td></tr> <tr><td>0x09</td><td>odr_200</td><td>200</td></tr> <tr><td>0x0a</td><td>odr_400</td><td>400</td></tr> <tr><td>0x0b</td><td>odr_800</td><td>800</td></tr> <tr><td>0x0c</td><td>odr_1k6</td><td>1600</td></tr> <tr><td>0x0d</td><td>odr_3k2</td><td>Reserved</td></tr> <tr><td>0x0e</td><td>odr_6k4</td><td>Reserved</td></tr> <tr><td>0x0f</td><td>odr_12k8</td><td>Reserved</td></tr> </tbody> </table>	Value	Name	Description	0x00	reserved	Reserved	0x01	odr_0p78	25/32	0x02	odr_1p5	25/16	0x03	odr_3p1	25/8	0x04	odr_6p25	25/4	0x05	odr_12p5	25/2	0x06	odr_25	25	0x07	odr_50	50	0x08	odr_100	100	0x09	odr_200	200	0x0a	odr_400	400	0x0b	odr_800	800	0x0c	odr_1k6	1600	0x0d	odr_3k2	Reserved	0x0e	odr_6k4	Reserved	0x0f	odr_12k8	Reserved	0x8
Value	Name	Description																																																					
0x00	reserved	Reserved																																																					
0x01	odr_0p78	25/32																																																					
0x02	odr_1p5	25/16																																																					
0x03	odr_3p1	25/8																																																					
0x04	odr_6p25	25/4																																																					
0x05	odr_12p5	25/2																																																					
0x06	odr_25	25																																																					
0x07	odr_50	50																																																					
0x08	odr_100	100																																																					
0x09	odr_200	200																																																					
0x0a	odr_400	400																																																					
0x0b	odr_800	800																																																					
0x0c	odr_1k6	1600																																																					
0x0d	odr_3k2	Reserved																																																					
0x0e	odr_6k4	Reserved																																																					
0x0f	odr_12k8	Reserved																																																					
	6...4	acc_bwp	<p>Bandwidth parameter determines filter configuration (acc_filt_perf=1) and averaging for undersampling mode (acc_filt_perf=0)</p> <table border="1"> <thead> <tr> <th>Value</th> <th>Name</th> <th>Description</th> </tr> </thead> <tbody> <tr> <td>0x00</td> <td>osr4_avg1</td> <td>acc_filt_perf = 1 -&gt; OSR4 mode; acc_filt_perf = 0 -&gt; no averaging</td> </tr> <tr> <td>0x01</td> <td>osr2_avg2</td> <td>acc_filt_perf = 1 -&gt; OSR2 mode; acc_filt_perf = 0 -&gt; average 2 samples</td> </tr> <tr> <td>0x02</td> <td>norm_avg4</td> <td>acc_filt_perf = 1 -&gt; normal mode;</td> </tr> </tbody> </table>	Value	Name	Description	0x00	osr4_avg1	acc_filt_perf = 1 -> OSR4 mode; acc_filt_perf = 0 -> no averaging	0x01	osr2_avg2	acc_filt_perf = 1 -> OSR2 mode; acc_filt_perf = 0 -> average 2 samples	0x02	norm_avg4	acc_filt_perf = 1 -> normal mode;	0x2	RW																																						
Value	Name	Description																																																					
0x00	osr4_avg1	acc_filt_perf = 1 -> OSR4 mode; acc_filt_perf = 0 -> no averaging																																																					
0x01	osr2_avg2	acc_filt_perf = 1 -> OSR2 mode; acc_filt_perf = 0 -> average 2 samples																																																					
0x02	norm_avg4	acc_filt_perf = 1 -> normal mode;																																																					



			0x03 cic_avg8 acc_filt_perf = 0 -> average 4 samples acc_filt_perf = 1 -> CIC mode; 0x04 res_avg16 acc_filt_perf = 0 -> average 8 samples acc_filt_perf = 1 -> Reserved; 0x05 res_avg32 acc_filt_perf = 0 -> average 16 samples acc_filt_perf = 1 -> Reserved; 0x06 res_avg64 acc_filt_perf = 0 -> average 32 samples acc_filt_perf = 1 -> Reserved; 0x07 res_avg128 acc_filt_perf = 0 -> average 64 samples acc_filt_perf = 1 -> Reserved; acc_filt_perf = 0 -> average 128 samples											
	7	acc_filter_perf	Select accelerometer filter performance mode: <table border="1"> <thead> <tr> <th>Value</th> <th>Name</th> <th>Description</th> </tr> </thead> <tbody> <tr> <td>0x00</td> <td>ulp</td> <td>power optimized</td> </tr> <tr> <td>0x01</td> <td>hp</td> <td>performance opt.</td> </tr> </tbody> </table>	Value	Name	Description	0x00	ulp	power optimized	0x01	hp	performance opt.	0x1	RW
Value	Name	Description												
0x00	ulp	power optimized												
0x01	hp	performance opt.												

### Register (0x41) ACC\_RANGE

DESCRIPTION: Selection of the Accelerometer g-range

RESET: 0x02

DEFINITION (Go to [register map](#)):

Address	Bit	Name	Description	Reset	Access															
0x41		ACC_RANGE		0x02																
	1...0	acc_range	Accelerometer g-range <table border="1"> <thead> <tr> <th>Value</th> <th>Name</th> <th>Description</th> </tr> </thead> <tbody> <tr> <td>0x00</td> <td>range_2g</td> <td>+/-2g</td> </tr> <tr> <td>0x01</td> <td>range_4g</td> <td>+/-4g</td> </tr> <tr> <td>0x02</td> <td>range_8g</td> <td>+/-8g</td> </tr> <tr> <td>0x03</td> <td>range_16g</td> <td>+/-16g</td> </tr> </tbody> </table>	Value	Name	Description	0x00	range_2g	+/-2g	0x01	range_4g	+/-4g	0x02	range_8g	+/-8g	0x03	range_16g	+/-16g	0x2	RW
Value	Name	Description																		
0x00	range_2g	+/-2g																		
0x01	range_4g	+/-4g																		
0x02	range_8g	+/-8g																		
0x03	range_16g	+/-16g																		

## Register (0x42) GYR\_CONF

DESCRIPTION: Sets the output data rate and the bandwidth of the Gyroscope in the sensor

RESET: 0xA9

DEFINITION (Go to [register map](#)):

Address	Bit	Name	Description	Reset	Access																																																			
0x42		GYR_CONF		0xA9																																																				
	3...0	gyr_odr	ODR in Hz <table border="1"> <thead> <tr> <th>Value</th> <th>Name</th> <th>Description</th> </tr> </thead> <tbody> <tr><td>0x00</td><td>reserved</td><td>Reserved</td></tr> <tr><td>0x01</td><td>odr_0p78</td><td>Reserved</td></tr> <tr><td>0x02</td><td>odr_1p5</td><td>Reserved</td></tr> <tr><td>0x03</td><td>odr_3p1</td><td>Reserved</td></tr> <tr><td>0x04</td><td>odr_6p25</td><td>Reserved</td></tr> <tr><td>0x05</td><td>odr_12p5</td><td>Reserved</td></tr> <tr><td>0x06</td><td>odr_25</td><td>25</td></tr> <tr><td>0x07</td><td>odr_50</td><td>50</td></tr> <tr><td>0x08</td><td>odr_100</td><td>100</td></tr> <tr><td>0x09</td><td>odr_200</td><td>200</td></tr> <tr><td>0x0a</td><td>odr_400</td><td>400</td></tr> <tr><td>0x0b</td><td>odr_800</td><td>800</td></tr> <tr><td>0x0c</td><td>odr_1k6</td><td>1600</td></tr> <tr><td>0x0d</td><td>odr_3k2</td><td>3200</td></tr> <tr><td>0x0e</td><td>odr_6k4</td><td>Reserved</td></tr> <tr><td>0x0f</td><td>odr_12k8</td><td>Reserved</td></tr> </tbody> </table>	Value	Name	Description	0x00	reserved	Reserved	0x01	odr_0p78	Reserved	0x02	odr_1p5	Reserved	0x03	odr_3p1	Reserved	0x04	odr_6p25	Reserved	0x05	odr_12p5	Reserved	0x06	odr_25	25	0x07	odr_50	50	0x08	odr_100	100	0x09	odr_200	200	0x0a	odr_400	400	0x0b	odr_800	800	0x0c	odr_1k6	1600	0x0d	odr_3k2	3200	0x0e	odr_6k4	Reserved	0x0f	odr_12k8	Reserved	0x9	RW
Value	Name	Description																																																						
0x00	reserved	Reserved																																																						
0x01	odr_0p78	Reserved																																																						
0x02	odr_1p5	Reserved																																																						
0x03	odr_3p1	Reserved																																																						
0x04	odr_6p25	Reserved																																																						
0x05	odr_12p5	Reserved																																																						
0x06	odr_25	25																																																						
0x07	odr_50	50																																																						
0x08	odr_100	100																																																						
0x09	odr_200	200																																																						
0x0a	odr_400	400																																																						
0x0b	odr_800	800																																																						
0x0c	odr_1k6	1600																																																						
0x0d	odr_3k2	3200																																																						
0x0e	odr_6k4	Reserved																																																						
0x0f	odr_12k8	Reserved																																																						
	5...4	gyr_bwp	The Gyroscope bandwidth coefficient defines the 3 dB cutoff frequency of the low pass filter for the sensor data <table border="1"> <thead> <tr> <th>Value</th> <th>Name</th> <th>Description</th> </tr> </thead> <tbody> <tr><td>0x00</td><td>osr4</td><td>OSR4 mode</td></tr> <tr><td>0x01</td><td>osr2</td><td>OSR2 mode</td></tr> <tr><td>0x02</td><td>norm</td><td>normal mode</td></tr> <tr><td>0x03</td><td>res</td><td>reserved</td></tr> </tbody> </table>	Value	Name	Description	0x00	osr4	OSR4 mode	0x01	osr2	OSR2 mode	0x02	norm	normal mode	0x03	res	reserved	0x2	RW																																				
Value	Name	Description																																																						
0x00	osr4	OSR4 mode																																																						
0x01	osr2	OSR2 mode																																																						
0x02	norm	normal mode																																																						
0x03	res	reserved																																																						
	6	gyr_noise_perf	Select noise performance: <table border="1"> <thead> <tr> <th>Value</th> <th>Name</th> <th>Description</th> </tr> </thead> <tbody> <tr><td>0x00</td><td>ulp</td><td>power optimized</td></tr> <tr><td>0x01</td><td>hp</td><td>performance opt.</td></tr> </tbody> </table>	Value	Name	Description	0x00	ulp	power optimized	0x01	hp	performance opt.	0x0	RW																																										
Value	Name	Description																																																						
0x00	ulp	power optimized																																																						
0x01	hp	performance opt.																																																						
	7	gyr_filter_perf	Select gyroscope filter performance mode: <table border="1"> <thead> <tr> <th>Value</th> <th>Name</th> <th>Description</th> </tr> </thead> <tbody> <tr><td>0x00</td><td>ulp</td><td>power optimized</td></tr> <tr><td>0x01</td><td>hp</td><td>performance opt.</td></tr> </tbody> </table>	Value	Name	Description	0x00	ulp	power optimized	0x01	hp	performance opt.	0x1	RW																																										
Value	Name	Description																																																						
0x00	ulp	power optimized																																																						
0x01	hp	performance opt.																																																						

## Register (0x43) GYR\_RANGE

DESCRIPTION: Defines the Gyroscope angular rate measurement range

RESET: 0x00

DEFINITION (Go to [register map](#)):

Address	Bit	Name	Description	Reset	Access																	
0x43		GYR_RANGE		0x00																		
	2...0	gyr_range	Full scale, Resolution <table border="1"> <thead> <tr> <th>Value</th> <th>Name</th> <th>Description</th> </tr> </thead> <tbody> <tr> <td>0x00</td> <td>range_2000</td> <td>+/-2000dps, 16.4 LSB/dps</td> </tr> <tr> <td>0x01</td> <td>range_1000</td> <td>+/-1000dps, 32.8 LSB/dps</td> </tr> <tr> <td>0x02</td> <td>range_500</td> <td>+/-500dps, 65.6 LSB/dps</td> </tr> <tr> <td>0x03</td> <td>range_250</td> <td>+/-250dps, 131.2 LSB/dps</td> </tr> <tr> <td>0x04</td> <td>range_125</td> <td>+/-125dps, 262.4 LSB/dps</td> </tr> </tbody> </table>	Value	Name	Description	0x00	range_2000	+/-2000dps, 16.4 LSB/dps	0x01	range_1000	+/-1000dps, 32.8 LSB/dps	0x02	range_500	+/-500dps, 65.6 LSB/dps	0x03	range_250	+/-250dps, 131.2 LSB/dps	0x04	range_125	+/-125dps, 262.4 LSB/dps	0x0
Value	Name	Description																				
0x00	range_2000	+/-2000dps, 16.4 LSB/dps																				
0x01	range_1000	+/-1000dps, 32.8 LSB/dps																				
0x02	range_500	+/-500dps, 65.6 LSB/dps																				
0x03	range_250	+/-250dps, 131.2 LSB/dps																				
0x04	range_125	+/-125dps, 262.4 LSB/dps																				
3		ois_range	Full scale, Resolution <table border="1"> <thead> <tr> <th>Value</th> <th>Name</th> <th>Description</th> </tr> </thead> <tbody> <tr> <td>0x00</td> <td>range_250</td> <td>+/-250dps, 131.2 LSB/dps</td> </tr> <tr> <td>0x01</td> <td>range_2000</td> <td>+/-2000dps, 16.4 LSB/dps</td> </tr> </tbody> </table>	Value	Name	Description	0x00	range_250	+/-250dps, 131.2 LSB/dps	0x01	range_2000	+/-2000dps, 16.4 LSB/dps	0x0	RW								
	Value	Name	Description																			
0x00	range_250	+/-250dps, 131.2 LSB/dps																				
0x01	range_2000	+/-2000dps, 16.4 LSB/dps																				

## Register (0x44) AUX\_CONF

DESCRIPTION: Sets the output data rate of the Auxiliary sensor interface

RESET: 0x46

DEFINITION (Go to [register map](#)):

Address	Bit	Name	Description	Reset	Access																																																			
0x44		AUX_CONF		0x46																																																				
	3...0	aux_odr	<p>define the poll rate for the magnetometer attached to the Auxiliary sensor interface. This is independent of the power mode setting for the sensor. The output data rate in Hz. In addition to setting the poll rate, it is required to configure the Auxiliary sensor properly using the AUX_IF_CONF register.</p> <table border="1"> <thead> <tr> <th>Value</th> <th>Name</th> <th>Description</th> </tr> </thead> <tbody> <tr><td>0x00</td><td>reserved</td><td>Reserved</td></tr> <tr><td>0x01</td><td>odr_0p78</td><td>25/32</td></tr> <tr><td>0x02</td><td>odr_1p5</td><td>25/16</td></tr> <tr><td>0x03</td><td>odr_3p1</td><td>25/8</td></tr> <tr><td>0x04</td><td>odr_6p25</td><td>25/4</td></tr> <tr><td>0x05</td><td>odr_12p5</td><td>25/2</td></tr> <tr><td>0x06</td><td>odr_25</td><td>25</td></tr> <tr><td>0x07</td><td>odr_50</td><td>50</td></tr> <tr><td>0x08</td><td>odr_100</td><td>100</td></tr> <tr><td>0x09</td><td>odr_200</td><td>200</td></tr> <tr><td>0x0a</td><td>odr_400</td><td>400</td></tr> <tr><td>0x0b</td><td>odr_800</td><td>800</td></tr> <tr><td>0x0c</td><td>odr_1k6</td><td>Reserved</td></tr> <tr><td>0x0d</td><td>odr_3k2</td><td>Reserved</td></tr> <tr><td>0x0e</td><td>odr_6k4</td><td>Reserved</td></tr> <tr><td>0x0f</td><td>odr_12k8</td><td>Reserved</td></tr> </tbody> </table>	Value	Name	Description	0x00	reserved	Reserved	0x01	odr_0p78	25/32	0x02	odr_1p5	25/16	0x03	odr_3p1	25/8	0x04	odr_6p25	25/4	0x05	odr_12p5	25/2	0x06	odr_25	25	0x07	odr_50	50	0x08	odr_100	100	0x09	odr_200	200	0x0a	odr_400	400	0x0b	odr_800	800	0x0c	odr_1k6	Reserved	0x0d	odr_3k2	Reserved	0x0e	odr_6k4	Reserved	0x0f	odr_12k8	Reserved	0x6	RW
Value	Name	Description																																																						
0x00	reserved	Reserved																																																						
0x01	odr_0p78	25/32																																																						
0x02	odr_1p5	25/16																																																						
0x03	odr_3p1	25/8																																																						
0x04	odr_6p25	25/4																																																						
0x05	odr_12p5	25/2																																																						
0x06	odr_25	25																																																						
0x07	odr_50	50																																																						
0x08	odr_100	100																																																						
0x09	odr_200	200																																																						
0x0a	odr_400	400																																																						
0x0b	odr_800	800																																																						
0x0c	odr_1k6	Reserved																																																						
0x0d	odr_3k2	Reserved																																																						
0x0e	odr_6k4	Reserved																																																						
0x0f	odr_12k8	Reserved																																																						
	7...4	aux_offset	trigger-readout offset in units of 2.5 ms. If set to zero, the offset is maximum, i.e. after readout a trigger is issued immediately.	0x4	RW																																																			

## Register (0x45) FIFO\_DOWNS

DESCRIPTION: Configure Gyroscope and Accelerometer downsampling rates for FIFO

RESET: 0x88

DEFINITION (Go to [register map](#)):

Address	Bit	Name	Description	Reset	Access									
0x45		FIFO_DOWNS		0x88										
	2...0	gyr_fifo_downs	Downsampling for Gyroscope (2**downs_gyro)	0x0	RW									
	3	gyr_fifo_filt_data	selects filtered or unfiltered Gyroscope data for fifo <table border="1"> <thead> <tr> <th>Value</th> <th>Name</th> <th>Description</th> </tr> </thead> <tbody> <tr> <td>0x00</td> <td>unfiltered</td> <td>Unfiltered data</td> </tr> <tr> <td>0x01</td> <td>filtered</td> <td>Filtered data</td> </tr> </tbody> </table>	Value	Name	Description	0x00	unfiltered	Unfiltered data	0x01	filtered	Filtered data	0x1	RW
	Value	Name	Description											
	0x00	unfiltered	Unfiltered data											
0x01	filtered	Filtered data												
6...4	acc_fifo_downs	Downsampling for Accelerometer (2**downs_accel)	0x0	RW										
7	acc_fifo_filt_data	selects filtered or unfiltered Accelerometer data for fifo <table border="1"> <thead> <tr> <th>Value</th> <th>Name</th> <th>Description</th> </tr> </thead> <tbody> <tr> <td>0x00</td> <td>unfiltered</td> <td>Unfiltered data</td> </tr> <tr> <td>0x01</td> <td>filtered</td> <td>Filtered data</td> </tr> </tbody> </table>	Value	Name	Description	0x00	unfiltered	Unfiltered data	0x01	filtered	Filtered data	0x1	RW	
Value	Name	Description												
0x00	unfiltered	Unfiltered data												
0x01	filtered	Filtered data												

## Register (0x46) FIFO\_WTM\_0

DESCRIPTION: FIFO Watermark level LSB

RESET: 0x00

DEFINITION (Go to [register map](#)):

Address	Bit	Name	Description	Reset	Access
0x46		FIFO_WTM_0		0x00	
	7...0	fifo_water_mark_7_0	Trigger an interrupt when FIFO contains fifo_water_mark_7_0+fifo_water_mark_12_8*256 bytes	0x0	RW

## Register (0x47) FIFO\_WTM\_1

DESCRIPTION: FIFO Watermark level MSB and frame content configuration

RESET: 0x02

DEFINITION (Go to [register map](#)):

Address	Bit	Name	Description	Reset	Access
0x47		FIFO_WTM_1		0x02	
	4...0	fifo_water_mark_1_2_8	Trigger an interrupt when FIFO contains fifo_water_mark_7_0+fifo_water_mark_12_8*256 bytes	0x2	RW

## Register (0x48) FIFO\_CONFIG\_0

DESCRIPTION: FIFO frame content configuration

RESET: 0x02

DEFINITION (Go to [register map](#)):

Address	Bit	Name	Description	Reset	Access
0x48		FIFO_CONFIG_0		0x02	
	0	fifo_stop_on_full	Stop writing samples into FIFO when FIFO is full. <b>Value Name Description</b> 0x00 disable do not stop writing to FIFO when full 0x01 enable Stop writing into FIFO when full.	0x0	RW
	1	fifo_time_en	Return sensortime frame after the last valid data frame. <b>Value Name Description</b> 0x00 disable do not return sensortime frame 0x01 enable return sensortime frame	0x1	RW

## Register (0x49) FIFO\_CONFIG\_1

DESCRIPTION: FIFO frame content configuration

RESET: 0x10

DEFINITION (Go to [register map](#)):

Address	Bit	Name	Description	Reset	Access
0x49		FIFO_CONFIG_1		0x10	
	1...0	fifo_tag_int1_en	FIFO interrupt 1 tag enable <b>Value Name Description</b> 0x00 int_edge enable tag on rising edge of int pin 0x01 int_level enable tag on level value of int pin 0x02 acc_sat enable tag on saturation of accelerometer data 0x03 gyr_sat enable tag on saturation of gyroscope data	0x0	RW
	3...2	fifo_tag_int2_en	FIFO interrupt 2 tag enable <b>Value Name Description</b> 0x00 int_edge enable tag on rising edge of int pin 0x01 int_level enable tag on level value of int pin	0x0	RW

			0x02    acc_sat    enable tag on saturation of accelerometer data											
			0x03    gyr_sat    enable tag on saturation of gyroscope data											
4	fifo_header_en	FIFO frame header enable	<table border="1"> <thead> <tr> <th>Value</th> <th>Name</th> <th>Description</th> </tr> </thead> <tbody> <tr> <td>0x00</td> <td>disable</td> <td>no header is stored (output data rate of all enabled sensors need to be identical)</td> </tr> <tr> <td>0x01</td> <td>enable</td> <td>header is stored</td> </tr> </tbody> </table>	Value	Name	Description	0x00	disable	no header is stored (output data rate of all enabled sensors need to be identical)	0x01	enable	header is stored	0x1	RW
Value	Name	Description												
0x00	disable	no header is stored (output data rate of all enabled sensors need to be identical)												
0x01	enable	header is stored												
5	fifo_aux_en	Store Auxiliary sensor data in FIFO (all 3 axes)	<table border="1"> <thead> <tr> <th>Value</th> <th>Name</th> <th>Description</th> </tr> </thead> <tbody> <tr> <td>0x00</td> <td>disable</td> <td>no Auxiliary sensor data is stored</td> </tr> <tr> <td>0x01</td> <td>enable</td> <td>Auxiliary sensor data is stored</td> </tr> </tbody> </table>	Value	Name	Description	0x00	disable	no Auxiliary sensor data is stored	0x01	enable	Auxiliary sensor data is stored	0x0	RW
Value	Name	Description												
0x00	disable	no Auxiliary sensor data is stored												
0x01	enable	Auxiliary sensor data is stored												
6	fifo_acc_en	Store Accelerometer data in FIFO (all 3 axes)	<table border="1"> <thead> <tr> <th>Value</th> <th>Name</th> <th>Description</th> </tr> </thead> <tbody> <tr> <td>0x00</td> <td>disable</td> <td>no Accelerometer data is stored</td> </tr> <tr> <td>0x01</td> <td>enable</td> <td>Accelerometer data is stored</td> </tr> </tbody> </table>	Value	Name	Description	0x00	disable	no Accelerometer data is stored	0x01	enable	Accelerometer data is stored	0x0	RW
Value	Name	Description												
0x00	disable	no Accelerometer data is stored												
0x01	enable	Accelerometer data is stored												
7	fifo_gyr_en	Store Gyroscope data in FIFO (all 3 axes)	<table border="1"> <thead> <tr> <th>Value</th> <th>Name</th> <th>Description</th> </tr> </thead> <tbody> <tr> <td>0x00</td> <td>disable</td> <td>no Gyroscope data is stored</td> </tr> <tr> <td>0x01</td> <td>enable</td> <td>Gyroscope data is stored</td> </tr> </tbody> </table>	Value	Name	Description	0x00	disable	no Gyroscope data is stored	0x01	enable	Gyroscope data is stored	0x0	RW
Value	Name	Description												
0x00	disable	no Gyroscope data is stored												
0x01	enable	Gyroscope data is stored												

## Register (0x4A) SATURATION

DESCRIPTION: Contains the information if one of the raw data samples used to generate current filtered data sample has been saturated (reached 0x8001 or 0x7FFF). The register is updated synchronous to the corresponding data registers in DATA\_0..19.

RESET: 0x00

DEFINITION (Go to [register map](#)):

Address	Bit	Name	Description	Reset	Access
0x4A		SATURATION		0x00	
	0	acc_x	ACC X-axis raw data saturation flag.	0x0	R
	1	acc_y	ACC Y-axis raw data saturation flag.	0x0	R
	2	acc_z	ACC Z-axis raw data saturation flag.	0x0	R
	3	gyr_x	GYR X-axis raw data saturation flag.	0x0	R
	4	gyr_y	GYR Y-axis raw data saturation flag.	0x0	R
	5	gyr_z	GYR Z-axis raw data saturation flag.	0x0	R

## Register (0x4B) AUX\_DEV\_ID

DESCRIPTION: Auxiliary interface device\_id

RESET: 0x20

DEFINITION (Go to [register map](#)):

Address	Bit	Name	Description	Reset	Access
0x4B		AUX_DEV_ID		0x20	
	7...1	i2c_device_addr	I2C device address of Auxiliary sensor	0x10	RW

## Register (0x4C) AUX\_IF\_CONF

DESCRIPTION: Auxiliary interface configuration register

RESET: 0x83

DEFINITION (Go to [register map](#)):

Address	Bit	Name	Description	Reset	Access
0x4C		AUX_IF_CONF		0x83	
	1...0	aux_rd_burst	Burst data length (1,2,6,8 byte) <b>Value</b> <b>Name</b> <b>Description</b> 0x00 BL1 Burst length 1 0x01 BL2 Burst length 2 0x02 BL6 Burst length 6 0x03 BL8 Burst length 8	0x3	RW
	3...2	man_rd_burst	Manual burst data length (1,2,6,8 byte) <b>Value</b> <b>Name</b> <b>Description</b> 0x00 BL1 Burst length 1 0x01 BL2 Burst length 2 0x02 BL6 Burst length 6 0x03 BL8 Burst length 8	0x0	RW



	6	aux_fcu_write_en	enables FCU write command on AUX IF for auxiliary sensors that need a trigger.	0x0	RW
	7	aux_manual_en	switches auxiliary interface between automatic and manual mode. In manual mode all read and write operations on auxiliary interface must be triggered manually; in automatic mode (aux_manual_en = "0") FCU triggers read and write operations periodically (as programmed by user).	0x1	RW

### Register (0x4D) AUX\_RD\_ADDR

DESCRIPTION: Auxiliary interface read address

RESET: 0x42

DEFINITION (Go to [register map](#)):

Address	Bit	Name	Description	Reset	Access
0x4D		AUX_RD_ADDR		0x42	
	7...0	read_addr	Address to read. In manual mode it triggers the read operation.	0x42	RW

### Register (0x4E) AUX\_WR\_ADDR

DESCRIPTION: Auxiliary interface write address

RESET: 0x4C

DEFINITION (Go to [register map](#)):

Address	Bit	Name	Description	Reset	Access
0x4E		AUX_WR_ADDR		0x4C	
	7...0	write_addr	Address to write. In manual mode it triggers the write operation.	0x4C	RW

### Register (0x4F) AUX\_WR\_DATA

DESCRIPTION: Auxiliary interface write data

RESET: 0x02

DEFINITION (Go to [register map](#)):

Address	Bit	Name	Description	Reset	Access
0x4F		AUX_WR_DATA		0x02	
	7...0	write_data	Data to write	0x2	RW

## Register (0x52) ERR\_REG\_MSK

DESCRIPTION: Defines which error flag will trigger the error interrupt once enabled

'1' - use to generate the error interrupt

'0' - do not use to generate error interrupt

RESET: 0x00

DEFINITION (Go to [register map](#)):

Address	Bit	Name	Description	Reset	Access
0x52		ERR_REG_MSK		0x00	
	0	fatal_err	Use fatal error to generate the error interrupt.	0x0	RW
	4...1	internal_err	Use internal error to generate the error interrupt	0x0	RW
	6	fifo_err	Use fifo error to generate the error interrupt.	0x0	RW
	7	aux_err	Use aux interface error to generate the error interrupt.	0x0	RW

## Register (0x53) INT1\_IO\_CTRL

DESCRIPTION: Configure the electrical behavior of the interrupt pin INT1

RESET: 0x00

DEFINITION (Go to [register map](#)):

Address	Bit	Name	Description	Reset	Access									
0x53		INT1_IO_CTRL		0x00										
	1	lvl	Configure level of INT1 pin <table border="1"> <thead> <tr> <th>Value</th> <th>Name</th> <th>Description</th> </tr> </thead> <tbody> <tr> <td>0x00</td> <td>active_low</td> <td>active low</td> </tr> <tr> <td>0x01</td> <td>active_high</td> <td>active high</td> </tr> </tbody> </table>	Value	Name	Description	0x00	active_low	active low	0x01	active_high	active high	0x0	RW
	Value	Name	Description											
	0x00	active_low	active low											
	0x01	active_high	active high											
2	od	Configure behaviour of INT1 pin <table border="1"> <thead> <tr> <th>Value</th> <th>Name</th> <th>Description</th> </tr> </thead> <tbody> <tr> <td>0x00</td> <td>push_pull</td> <td>push-pull</td> </tr> <tr> <td>0x01</td> <td>open_drain</td> <td>open drain</td> </tr> </tbody> </table>	Value	Name	Description	0x00	push_pull	push-pull	0x01	open_drain	open drain	0x0	RW	
Value	Name	Description												
0x00	push_pull	push-pull												
0x01	open_drain	open drain												
3	output_en	Output enable for INT1 pin <table border="1"> <thead> <tr> <th>Value</th> <th>Name</th> <th>Description</th> </tr> </thead> <tbody> <tr> <td>0x00</td> <td>off</td> <td>Output disabled</td> </tr> <tr> <td>0x01</td> <td>on</td> <td>Output enabled</td> </tr> </tbody> </table>	Value	Name	Description	0x00	off	Output disabled	0x01	on	Output enabled	0x0	RW	
Value	Name	Description												
0x00	off	Output disabled												
0x01	on	Output enabled												
4	input_en	Input enable for INT1 pin <table border="1"> <thead> <tr> <th>Value</th> <th>Name</th> <th>Description</th> </tr> </thead> <tbody> <tr> <td>0x00</td> <td>off</td> <td>Input disabled</td> </tr> <tr> <td>0x01</td> <td>on</td> <td>Input enabled</td> </tr> </tbody> </table>	Value	Name	Description	0x00	off	Input disabled	0x01	on	Input enabled	0x0	RW	
Value	Name	Description												
0x00	off	Input disabled												
0x01	on	Input enabled												

## Register (0x54) INT2\_IO\_CTRL

DESCRIPTION: Configure the electrical behavior of the interrupt pin INT2

RESET: 0x00

DEFINITION (Go to [register map](#)):

Address	Bit	Name	Description	Reset	Access
0x54		INT2_IO_CTRL		0x00	
	1	lvl	Configure level of INT2 pin <b>Value</b> <b>Name</b> <b>Description</b> 0x00 active_low active low 0x01 active_high active high	0x0	RW
	2	od	Configure behaviour of INT2 pin <b>Value</b> <b>Name</b> <b>Description</b> 0x00 push_pull push-pull 0x01 open_drain open drain	0x0	RW
	3	output_en	Output enable for INT2 pin <b>Value</b> <b>Name</b> <b>Description</b> 0x00 off Output disabled 0x01 on Output enabled	0x0	RW
	4	input_en	Input enable for INT2 pin <b>Value</b> <b>Name</b> <b>Description</b> 0x00 off Input disabled 0x01 on Input enabled	0x0	RW

## Register (0x55) INT\_LATCH

DESCRIPTION: Configure interrupt modes

RESET: 0x00

DEFINITION (Go to [register map](#)):

Address	Bit	Name	Description	Reset	Access
0x55		INT_LATCH		0x00	
	0	int_latch	Latched/non-latched interrupt modes <b>Value</b> <b>Name</b> <b>Description</b> 0x00 none non latched 0x01 permanent permanent latched	0x0	RW

### Register (0x56) INT1\_MAP\_FEAT

DESCRIPTION: Interrupt/Feature mapping on INT1

RESET: 0x00

DEFINITION (Go to [register map](#)):

Address	Bit	Name	Description	Reset	Access
0x56		INT1_MAP_FEAT		0x00	
	0	sig_motion_out	Sigmotion output.	0x0	RW
	1	step_counter_out	Step-counter watermark or Step-detector output	0x0	RW
	2	activity_out	Step activity output	0x0	RW
	3	wrist_wear_wakeup_out	Wrist wear wakeup output	0x0	RW
	4	wrist_gesture_out	Wrist gesture output	0x0	RW
	5	no_motion_out	No motion detection output	0x0	RW
	6	any_motion_out	Any motion detection output	0x0	RW
	7	reserved	Reserved	0x0	RW

### Register (0x57) INT2\_MAP\_FEAT

DESCRIPTION: Interrupt/Feature mapping on INT2

RESET: 0x00

DEFINITION (Go to [register map](#)):

Address	Bit	Name	Description	Reset	Access
0x57		INT2_MAP_FEAT		0x00	
	0	sig_motion_out	Sigmotion output.	0x0	RW
	1	step_counter_out	Step-counter watermark or Step-detector output	0x0	RW
	2	activity_out	Step activity output	0x0	RW
	3	wrist_wear_wakeup_out	Wrist wear wakeup output	0x0	RW
	4	wrist_gesture_out	Wrist gesture output	0x0	RW
	5	no_motion_out	No motion detection output	0x0	RW
	6	any_motion_out	Any motion detection output	0x0	RW
	7	reserved	Reserved	0x0	RW

### Register (0x58) INT\_MAP\_DATA

DESCRIPTION: Data Interrupt mapping for both INT pins

RESET: 0x00

DEFINITION (Go to [register map](#)):

Address	Bit	Name	Description	Reset	Access
0x58		INT_MAP_DATA		0x00	
	0	ffull_int1	FIFO Full interrupt mapped to INT1	0x0	RW
	1	fwm_int1	FIFO Watermark interrupt mapped to INT1	0x0	RW
	2	drdy_int1	Data Ready interrupt mapped to INT1	0x0	RW
	3	err_int1	Error interrupt mapped to INT1	0x0	RW
	4	ffull_int2	FIFO Full interrupt mapped to INT2	0x0	RW
	5	fwm_int2	FIFO Watermark interrupt mapped to INT2	0x0	RW
	6	drdy_int2	Data Ready interrupt mapped to INT2	0x0	RW
	7	err_int2	Error interrupt mapped to INT2	0x0	RW

### Register (0x59) INIT\_CTRL

DESCRIPTION: Start initialization

RESET: 0x00

DEFINITION (Go to [register map](#)):

Address	Bit	Name	Description	Reset	Access
0x59		INIT_CTRL		0x00	
	7..0	init_ctrl	Start initialization	0x0	RW

### Register (0x5B) INIT\_ADDR\_0

DESCRIPTION: Base address of the initialization data. Increment by burst write length in bytes/2 after each burst write operation. Please ignore, if your host supports to load the initialization data in a single 8kB burst write operation.

RESET: 0x00

DEFINITION (Go to [register map](#)):

Address	Bit	Name	Description	Reset	Access
0x5B		INIT_ADDR_0		0x00	
	3..0	base_0_3	Bits 0 to 3 of the base address for initialization data.	0x0	RW

### Register (0x5C) INIT\_ADDR\_1

DESCRIPTION: Base address of the initialization data. Increment by burst write length in bytes/2 after each burst write operation. Please ignore, if your host supports to load the initialization data in a single 8kB burst write operation.

RESET: 0x00

DEFINITION (Go to [register map](#)):

Address	Bit	Name	Description	Reset	Access
0x5C		INIT_ADDR_1		0x00	
	7...0	base_11_4	Bits 4 to 11 of the base address for initialization data.	0x0	RW

### Register (0x5E) INIT\_DATA

DESCRIPTION: Initialization register

RESET: 0x00

DEFINITION (Go to [register map](#)):

Address	Bit	Name	Description	Reset	Access
0x5E		INIT_DATA		0x00	
	7...0	data	Register for initialization data	0x0	RW

### Register (0x5F) INTERNAL\_ERROR

DESCRIPTION: Internal error flags. Value of all reserved bits should be ignored.

RESET: 0x00

DEFINITION (Go to [register map](#)):

Address	Bit	Name	Description	Reset	Access
0x5F		INTERNAL_ERROR		0x00	
	1	int_err_1	Internal error flag - long processing time, processing halted	0x0	R
	2	int_err_2	Internal error flag - fatal error, processing halted	0x0	R
	4	feat_eng_disabled	Feature engine has been disabled by host during sensor operation	0x0	R

## Register (0x68) AUX\_IF\_TRIM

DESCRIPTION: Auxiliary interface trim register (NVM backed)

RESET: 0x01

DEFINITION (Go to [register map](#)):

Address	Bit	Name	Description	Reset	Access
0x68		AUX_IF_TRIM		0x01	
	1...0	asda_pupsel	Pullup configuration for ASDA <b>Value</b> <b>Name</b> <b>Description</b> 0x00 pup_res_off Pullup off 0x01 pup_res_40k Pullup 40k 0x02 pup_res_10k Pullup 10k 0x03 pup_res_2k Pullup 2k	0x1	RW
	2	spare3	(Spare NVM bits.)	0x0	RW

## Register (0x69) GYR\_CERT\_CONF

DESCRIPTION: Component Retrimming for Gyroscope

RESET: 0x00

DEFINITION (Go to [register map](#)):

Address	Bit	Name	Description	Reset	Access
0x69		GYR_CERT_CONF		0x00	
	2	crt_running	Indicates that CRT is currently running. If CRT completed, check CRT_STATUS register for the completion status <b>Value</b> <b>Name</b> <b>Description</b> 0x00 disabled disabled 0x01 enabled enabled	0x0	RW
	3	rdy_for_dl	pacemaker bit for downloading the CRT data <b>Value</b> <b>Name</b> <b>Description</b> 0x00 ongoing ongoing or not started 0x01 complete complete	0x0	R

## Register (0x6A) NVM\_CONF

DESCRIPTION: NVM Configuration

RESET: 0x00

DEFINITION (Go to [register map](#)):

Address	Bit	Name	Description	Reset	Access
0x6A		NVM_CONF		0x00	
	1	nvm_prog_en	Enable NVM programming. <b>Value Name Description</b> 0x00 disable disable 0x01 enable enable	0x0	RW

## Register (0x6B) IF\_CONF

DESCRIPTION: Serial interface settings

RESET: 0x00

DEFINITION (Go to [register map](#)):

Address	Bit	Name	Description	Reset	Access
0x6B		IF_CONF		0x00	
	0	spi3	Configure SPI Interface Mode for primary interface <b>Value Name Description</b> 0x00 spi4 SPI 4-wire mode 0x01 spi3 SPI 3-wire mode	0x0	RW
	1	spi3_ois	Configure SPI Interface Mode for OIS interface (if enabled) <b>Value Name Description</b> 0x00 spi4 SPI 4-wire mode 0x01 spi3 SPI 3-wire mode	0x0	RW
	4	ois_en	Interface configuration - OIS enable bit. It has lower priority than aux_en.	0x0	RW
	5	aux_en	Interface configuration - AUX enable bit. It has higher priority than ois_en.	0x0	RW

## Register (0x6C) DRV

DESCRIPTION: Drive strength control register (NVM backed)

RESET: 0xFF

DEFINITION (Go to [register map](#)):

Address	Bit	Name	Description	Reset	Access
0x6C		DRV		0xFF	
	2..0	io_pad_drv1	Output pad drive strength setting.	0x7	RW
	3	io_pad_i2c_b1	Output pad drive strength setting.	0x1	RW
	6..4	io_pad_drv2	Output pad drive strength setting.	0x7	RW
	7	io_pad_i2c_b2	Output pad drive strength setting.	0x1	RW



## Register (0x6D) ACC\_SELF\_TEST

DESCRIPTION: Settings for the accelerometer self-test configuration and trigger

RESET: 0x00

DEFINITION (Go to [register map](#)):

Address	Bit	Name	Description	Reset	Access
0x6D		ACC_SELF_TEST		0x00	
	0	acc_self_test_en	Enable accelerometer self-test <b>Value Name Description</b> 0x00 disabled disabled 0x01 enabled enabled	0x0	RW
	2	acc_self_test_sign	select sign of self-test excitation as <b>Value Name Description</b> 0x00 negative negative 0x01 positive positive	0x0	RW
	3	acc_self_test_amp	select amplitude of the selftest deflection: <b>Value Name Description</b> 0x00 low low 0x01 high high	0x0	RW

## Register (0x6E) GYR\_SELF\_TEST\_AXES

DESCRIPTION: Settings for the gyroscope AXES self-test configuration and trigger

RESET: 0x00

DEFINITION (Go to [register map](#)):

Address	Bit	Name	Description	Reset	Access
0x6E		GYR_SELF_TEST_AXES		0x00	
	0	gyr_st_axes_done	STATUS: functional test of detection channels finished.	0x0	R
	1	gyr_axis_x_ok	status of gyro X-axis self test	0x0	R
	2	gyr_axis_y_ok	status of gyro Y-axis self test	0x0	R
	3	gyr_axis_z_ok	status of gyro Z-axis self test	0x0	R

### Register (0x70) NV\_CONF

DESCRIPTION: NVM backed configuration bits.

RESET: 0x00

DEFINITION (Go to [register map](#)):

Address	Bit	Name	Description	Reset	Access
0x70		NV_CONF		0x00	
	0	spi_en	disable the I2C and enable SPI for the primary interface, when it is in autoconfig mode <b>Value Name Description</b> 0x00 disabled I2C enabled 0x01 enabled I2C disabled	0x0	RW
	1	i2c_wdt_sel	Select timer period for I2C Watchdog <b>Value Name Description</b> 0x00 short I2C watchdog timeout after 1.25 ms 0x01 long I2C watchdog timeout after 40 ms	0x0	RW
	2	i2c_wdt_en	I2C Watchdog at the SDI pin in I2C interface mode <b>Value Name Description</b> 0x00 Disable Disable I2C watchdog 0x01 Enable Enable I2C watchdog	0x0	RW
	3	acc_off_en	Add the offset defined in the off_acc_[xyz] OFFSET register to filtered and unfiltered Accelerometer data <b>Value Name Description</b> 0x00 disabled Disabled 0x01 enabled Enabled	0x0	RW

### Register (0x71) OFFSET\_0

DESCRIPTION: Offset compensation for Accelerometer X-axis (NVM backed)

RESET: 0x00

DEFINITION (Go to [register map](#)):

Address	Bit	Name	Description	Reset	Access
0x71		OFFSET_0		0x00	
	7...0	off_acc_x	Accelerometer offset compensation (X-axis).	0x0	RW

**Register (0x72) OFFSET\_1**

DESCRIPTION: Offset compensation for Accelerometer Y-axis (NVM backed)

RESET: 0x00

DEFINITION (Go to [register map](#)):

Address	Bit	Name	Description	Reset	Access
0x72		OFFSET_1		0x00	
	7...0	off_acc_y	Accelerometer offset compensation (Y-axis).	0x0	RW

**Register (0x73) OFFSET\_2**

DESCRIPTION: Offset compensation for Accelerometer Z-axis (NVM backed)

RESET: 0x00

DEFINITION (Go to [register map](#)):

Address	Bit	Name	Description	Reset	Access
0x73		OFFSET_2		0x00	
	7...0	off_acc_z	Accelerometer offset compensation (Z-axis).	0x0	RW

**Register (0x74) OFFSET\_3**

DESCRIPTION: Offset compensation for Gyroscope X-axis (NVM backed)

RESET: 0x00

DEFINITION (Go to [register map](#)):

Address	Bit	Name	Description	Reset	Access
0x74		OFFSET_3		0x00	
	7...0	gyr_usr_off_x_7_0	Gyroscope offset compensation (X-axis).	0x0	RW

**Register (0x75) OFFSET\_4**

DESCRIPTION: Offset compensation for Gyroscope Y-axis (NVM backed)

RESET: 0x00

DEFINITION (Go to [register map](#)):

Address	Bit	Name	Description	Reset	Access
0x75		OFFSET_4		0x00	
	7...0	gyr_usr_off_y_7_0	Gyroscope offset compensation (Y-axis).	0x0	RW

## Register (0x76) OFFSET\_5

DESCRIPTION: Offset compensation for Gyroscope Z-axis (NVM backed)

RESET: 0x00

DEFINITION (Go to [register map](#)):

Address	Bit	Name	Description	Reset	Access
0x76		OFFSET_5		0x00	
	7...0	gyr_usr_off_z_7_0	Gyroscope offset compensation (Z-axis).	0x0	RW

## Register (0x77) OFFSET\_6

DESCRIPTION: Offset compensation (MSBs gyroscope, enables) (NVM backed)

RESET: 0x00

DEFINITION (Go to [register map](#)):

Address	Bit	Name	Description	Reset	Access
0x77		OFFSET_6		0x00	
	1...0	gyr_usr_off_x_9_8	Gyroscope offset compensation (X-axis).	0x0	RW
	3...2	gyr_usr_off_y_9_8	Gyroscope offset compensation (Y-axis).	0x0	RW
	5...4	gyr_usr_off_z_9_8	Gyroscope offset compensation (Z-axis).	0x0	RW
	6	gyr_off_en	Add the offset defined in the gyr_usr_off_[xyz] OFFSET register to filtered and unfiltered Gyroscope data <b>Value</b> <b>Name</b> <b>Description</b> 0x00 disabled Disabled 0x01 enabled Enabled	0x0	RW
	7	gyr_gain_en	Compensate the gain as described in section "Sensitivity Error Compensation". <b>Value</b> <b>Name</b> <b>Description</b> 0x00 disabled Disabled 0x01 enabled Enabled	0x0	RW

## Register (0x7C) PWR\_CONF

DESCRIPTION: Power mode configuration register

RESET: 0x03

DEFINITION (Go to [register map](#)):

Address	Bit	Name	Description	Reset	Access
0x7C		PWR_CONF		0x03	
	0	adv_power_save	Advanced power save disabled. <b>Value</b> <b>Name</b> <b>Description</b> 0x00 aps_off Advanced power save disabled. 0x01 aps_on Advanced power mode enabled.	0x1	RW

1	fifo_self_wake_up	FIFO read disabled in low power mode	0x1	RW					
		<table border="1"> <thead> <tr> <th>Value</th> <th>Name</th> <th>Description</th> </tr> </thead> <tbody> <tr> <td>0x00</td> <td>fsw_off</td> <td>FIFO read disabled in low power mode</td> </tr> <tr> <td>0x01</td> <td>fsw_on</td> <td>FIFO read enabled in low power mode after FIFO interrupt is fired</td> </tr> </tbody> </table>	Value		Name	Description	0x00	fsw_off	FIFO read disabled in low power mode
Value	Name	Description							
0x00	fsw_off	FIFO read disabled in low power mode							
0x01	fsw_on	FIFO read enabled in low power mode after FIFO interrupt is fired							
2	fup_en	Fast power up enable	0x0	RW					
		<table border="1"> <thead> <tr> <th>Value</th> <th>Name</th> <th>Description</th> </tr> </thead> <tbody> <tr> <td>0x00</td> <td>fup_off</td> <td>Fast power up disabled</td> </tr> <tr> <td>0x01</td> <td>fup_on</td> <td>Fast power up enabled</td> </tr> </tbody> </table>	Value		Name	Description	0x00	fup_off	Fast power up disabled
Value	Name	Description							
0x00	fup_off	Fast power up disabled							
0x01	fup_on	Fast power up enabled							

### Register (0x7D) PWR\_CTRL

DESCRIPTION: Power mode control register

RESET: 0x00

DEFINITION (Go to [register map](#)):

Address	Bit	Name	Description	Reset	Access									
0x7D		PWR_CTRL		0x00										
	0	aux_en	<table border="1"> <thead> <tr> <th>Value</th> <th>Name</th> <th>Description</th> </tr> </thead> <tbody> <tr> <td>0x00</td> <td>aux_off</td> <td>Disables the Auxiliary sensor.</td> </tr> <tr> <td>0x01</td> <td>aux_on</td> <td>Enables the Auxiliary sensor.</td> </tr> </tbody> </table>	Value	Name	Description	0x00	aux_off	Disables the Auxiliary sensor.	0x01	aux_on	Enables the Auxiliary sensor.	0x0	RW
	Value	Name	Description											
	0x00	aux_off	Disables the Auxiliary sensor.											
	0x01	aux_on	Enables the Auxiliary sensor.											
1	gyr_en	<table border="1"> <thead> <tr> <th>Value</th> <th>Name</th> <th>Description</th> </tr> </thead> <tbody> <tr> <td>0x00</td> <td>gyr_off</td> <td>Disables the Gyroscope.</td> </tr> <tr> <td>0x01</td> <td>gyr_on</td> <td>Enables the Gyroscope.</td> </tr> </tbody> </table>	Value	Name	Description	0x00	gyr_off	Disables the Gyroscope.	0x01	gyr_on	Enables the Gyroscope.	0x0	RW	
Value	Name	Description												
0x00	gyr_off	Disables the Gyroscope.												
0x01	gyr_on	Enables the Gyroscope.												
2	acc_en	<table border="1"> <thead> <tr> <th>Value</th> <th>Name</th> <th>Description</th> </tr> </thead> <tbody> <tr> <td>0x00</td> <td>acc_off</td> <td>Disables the Accelerometer.</td> </tr> <tr> <td>0x01</td> <td>acc_on</td> <td>Enables the Accelerometer.</td> </tr> </tbody> </table>	Value	Name	Description	0x00	acc_off	Disables the Accelerometer.	0x01	acc_on	Enables the Accelerometer.	0x0	RW	
Value	Name	Description												
0x00	acc_off	Disables the Accelerometer.												
0x01	acc_on	Enables the Accelerometer.												
3	temp_en	<table border="1"> <thead> <tr> <th>Value</th> <th>Name</th> <th>Description</th> </tr> </thead> <tbody> <tr> <td>0x00</td> <td>temp_off</td> <td>Disables the Temperature sensor.</td> </tr> <tr> <td>0x01</td> <td>temp_on</td> <td>Enables the Temperature sensor.</td> </tr> </tbody> </table>	Value	Name	Description	0x00	temp_off	Disables the Temperature sensor.	0x01	temp_on	Enables the Temperature sensor.	0x0	RW	
Value	Name	Description												
0x00	temp_off	Disables the Temperature sensor.												
0x01	temp_on	Enables the Temperature sensor.												

## Register (0x7E) CMD

DESCRIPTION: Command Register

RESET: 0x00

DEFINITION (Go to [register map](#)):

Address	Bit	Name	Description	Reset	Access																		
0x7E		CMD		0x00																			
	7...0	cmd	<p>Available commands (Note: Register will always return 0x00 as read result):</p> <table border="1"> <thead> <tr> <th>Value</th> <th>Name</th> <th>Description</th> </tr> </thead> <tbody> <tr> <td>0x02</td> <td>g_trigger</td> <td>Trigger special gyro operations.</td> </tr> <tr> <td>0x03</td> <td>usr_gain</td> <td>Applies new gyro gain value.</td> </tr> <tr> <td>0xa0</td> <td>nvm_prog</td> <td>Writes the NVM backed registers into NVM</td> </tr> <tr> <td>0xb0</td> <td>fifo_flush</td> <td>Clears FIFO content</td> </tr> <tr> <td>0xb6</td> <td>softreset</td> <td>Triggers a reset, all user configuration settings are overwritten with their default state</td> </tr> </tbody> </table>	Value	Name	Description	0x02	g_trigger	Trigger special gyro operations.	0x03	usr_gain	Applies new gyro gain value.	0xa0	nvm_prog	Writes the NVM backed registers into NVM	0xb0	fifo_flush	Clears FIFO content	0xb6	softreset	Triggers a reset, all user configuration settings are overwritten with their default state	0x0	W
Value	Name	Description																					
0x02	g_trigger	Trigger special gyro operations.																					
0x03	usr_gain	Applies new gyro gain value.																					
0xa0	nvm_prog	Writes the NVM backed registers into NVM																					
0xb0	fifo_flush	Clears FIFO content																					
0xb6	softreset	Triggers a reset, all user configuration settings are overwritten with their default state																					

## 6. Digital Interfaces

### 6.1. Interfaces

Beside the standard primary interface (I2C and SPI configurable), where sensor acts as a slave to the application processor the IMU device supports a secondary interface. The secondary interface can be configured as either auxiliary interface (I2C master) or OIS interface (SPI slave). See picture below. Both secondary configurations work independent of the primary interface configuration, i.e. I2C or SPI between the device and application processor.

If the secondary interface configured as auxiliary interface, the device can be connected to an external sensor (e.g. a magnetometer) in order to build a 9-DoF solution. Then the device will act as a master to the external sensor, reading the sensor data automatically and providing it to the application processor via the primary interface.

Alternatively, the secondary interface can be used as OIS interface to connect to an external OIS control unit. The OIS control unit acts as a master and device as slave.

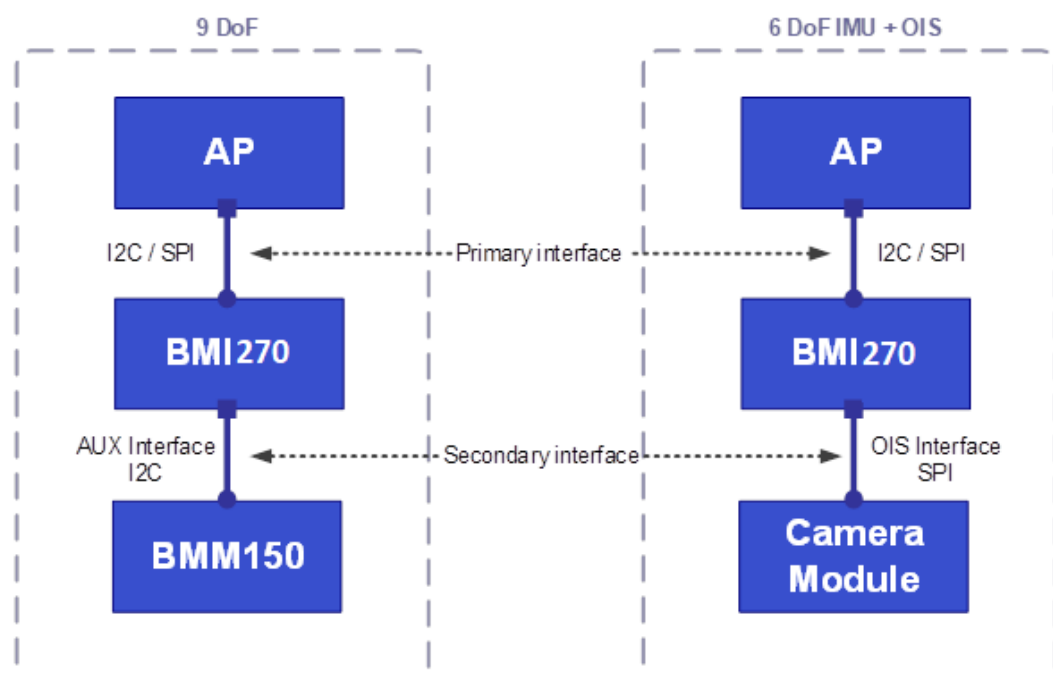

Figure 9: Digital Interfaces

## 6.2. Primary Interface

By default, the device operates in I2C mode. The device interface can also be configured to operate in a SPI 4-wire configuration. It can also be re-configured by software to work in 3-wire mode instead of 4-wire mode.

All three possible digital interfaces share partly the same pins. The mapping for the primary interface of device is given in the following table:

Table 17: Mapping for primary interface

PIN#	NAME	I/O TYPE	DESCRIPTION	CONNECT TO PRIMARY INTERFACE		
				IN SPI4W	IN SPI3W	IN I2C
1	SDO	Digital I/O	SDO Serial data output in SPI 4W I2C Address bit-0 select in I <sup>2</sup> C mode	SDO	DNC	GND for default I2C addr.
4	INT1	Digital I/O*	Interrupt pin 1	INT1	INT1	INT1
9	INT2	Digital I/O*	Interrupt pin 2	INT2	INT2	INT2
12	CSB	Digital in	Chip select for SPI mode	CSB	CSB	VDDIO**
13	SCx	Digital in	SCK for SPI serial clock SCL for I <sup>2</sup> C serial clock	SCK	SCK	SCL
14	SDx	Digital I/O	SDA serial data I/O in I <sup>2</sup> C SDI serial data input in SPI 4W SDA serial data I/O in SPI 3W	SDI	SDA	SDA

\* INT1 and/or INT2 can also be configured as an input in case the external data synchronization in FIFO is used. If INT1 and/or INT2 are not used, please do not connect them (DNC).

\*\* DNC is also possible due to an internal pull-up, as long as the voltage never drops below V<sub>IH</sub>.

The following table shows the electrical specifications of the interface pins:

Table 18: Electrical specifications of the interface pins

PARAMETER	SYMBOL	CONDITION	MIN	TYP	MAX	UNITS
Pull-up Resistance, CSB pin	R <sub>up</sub>	Internal Pull-up Resistance to VDDIO	75	100	140	kΩ
Input Capacitance	C <sub>in</sub>				5	pF
I <sup>2</sup> C Bus Load Capacitance (max. drive capability)	C <sub>I2C_Load</sub>				400	pF



### 6.3. Primary Interface Digital Protocol Selection

The protocol is automatically selected based on the chip select CSB pin behavior after power-up.

After reset / power-up, the device's primary interface is in I2C mode. If CSB is connected to VDDIO during power-up and not changed, the primary interface works in I2C mode. For using I2C, it is recommended to hard-wire the CSB line to VDDIO. Since power-on-reset is only executed when both VDD and VDDIO are established, there is no risk of incorrect protocol detection due to power-up sequence.

If CSB sees a rising edge after power-up, the device interface switches to SPI after 200  $\mu$ s until a reset or the next power-up occurs. Therefore, a CSB rising edge is needed before starting the SPI communication. Hence, it is recommended to perform a SPI single read of register CHIP\_ID (the obtained value will be invalid) before the actual communication start, in order to use the SPI interface. If toggling of the CSB bit is not possible without data communication, there is an addition the spi\_en bit in register NV\_CONF, which can be used to permanently set the primary interface to SPI without the need to toggle the CSB pin at every power-up or reset.

### 6.4. Primary Interface SPI

The timing specification for SPI of the device is given in the following table:

SPI timing, valid at  $V_{DDIO} \geq 1.62V$

Table 19: Timing specifications for SPI

PARAMETER	SYMBOL	CONDITION	MIN	MAX	UNITS
Clock Frequency	$f_{SPI}$	Max. Load on SDI or SDO = 30pF, $V_{DDIO} \geq 1.62V$		10	MHz
		$V_{DDIO} < 1.62V$		7	MHz
SCK Low Pulse	$t_{SCKL}$	$V_{DDIO} \geq 1.62V$	45		ns
SCK High Pulse	$t_{SCKH}$	$V_{DDIO} \geq 1.62V$	45		ns
SCK Low Pulse	$t_{SCKL}$	$V_{DDIO} < 1.62V$		66	ns
SCK High Pulse	$t_{SCKH}$	$V_{DDIO} < 1.62V$		66	ns
SDI Setup Time	$t_{SDI\_setup}$		20		ns
SDI Hold Time	$t_{SDI\_hold}$		20		ns
SDO Output Delay	$t_{SDO\_OD}$	Load = 30pF, $V_{DDIO} \geq 1.62V$		30	ns
CSB Setup Time	$t_{CSB\_setup}$		40		ns
CSB Hold Time	$t_{CSB\_hold}$		40		ns
Idle time after read access in any mode	$t_{IDLE\_rd}$		2		$\mu$ s
Idle time after write access in normal mode or fast startup mode	$t_{IDLE\_wr\_act}$		2		$\mu$ s
Idle time after a write access in suspend mode, low-power mode	$t_{IDLE\_wacc\_sum}$		450		$\mu$ s

The following figure shows the definition of the SPI timings:

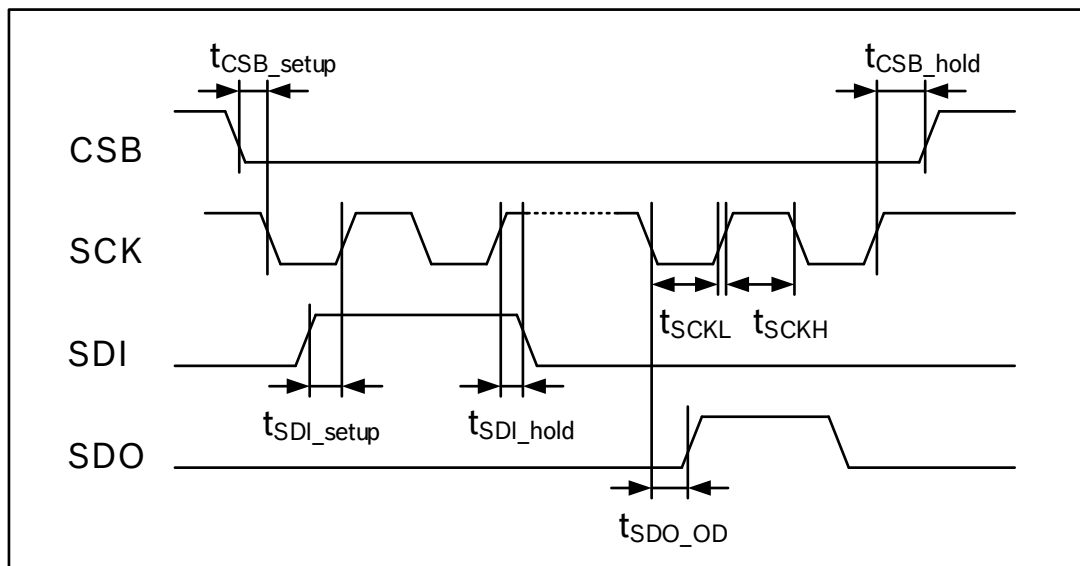

Figure 10: SPI timing diagram

The SPI interface of the device is compatible with two modes, '00' [CPOL = '0' and CPHA = '0'] and '11' [CPOL = '1' and CPHA = '1']. The automatic selection between '00' and '11' is controlled based on the value of SCK after a falling edge of CSB.

Two configurations of the SPI interface are supported by device: 4-wire and 3-wire. The same protocol is used by both configurations. The device operates in 4-wire configuration by default. It can be switched to 3-wire configuration by writing [IF\\_CONF.spi3](#) = 0b1. Pin SDX is used as the common data pin in 3-wire configuration. For single byte read as well as write operations, 16-bit protocols are used. device also supports multiple-byte read and write operations.

**In SPI 4-wire configuration** CSB (chip select low active), SCX ( as SCK for serial clock), SDX ( as SDI for serial data input), and SDO (serial data output) pins are used. The communication starts when the CSB is pulled low by the SPI master and stops when CSB is pulled high. SCK is also controlled by SPI master. SDI and SDO are driven at the falling edge of SCK and should be captured at the rising edge of SCK.

The basic write operation waveform for 4-wire configuration is depicted in the following figure. During the entire write cycle SDO remains in high-impedance state.

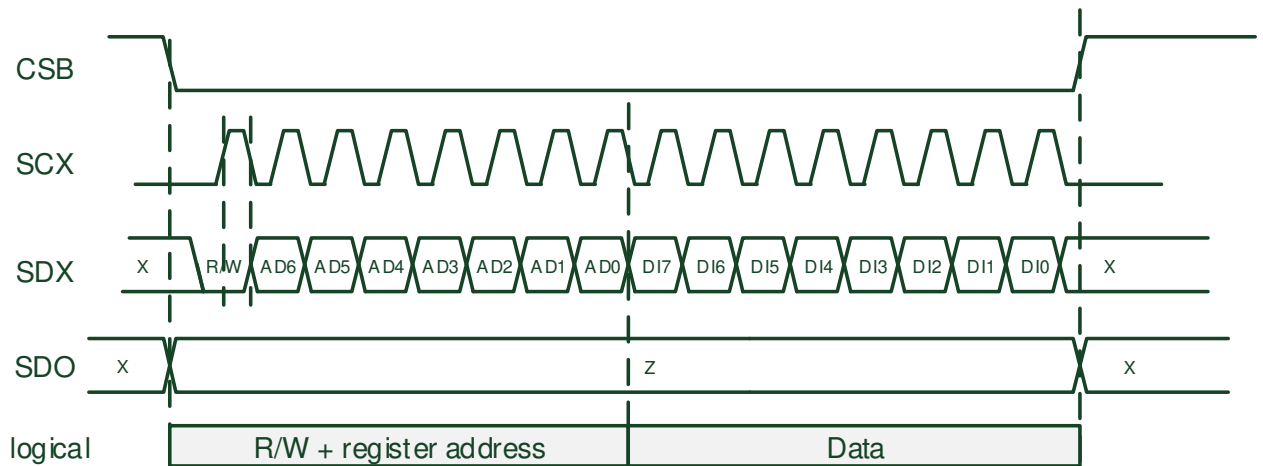

4-wire basic SPI write sequence (mode '00')

Multiple write operations are possible by keeping CSB low and continuing the data transfer. Only the first register's address has to be placed in SDX. Addresses are automatically incremented after each write access as long as CSB stays active low. The principle of multiple write is shown in figure below:

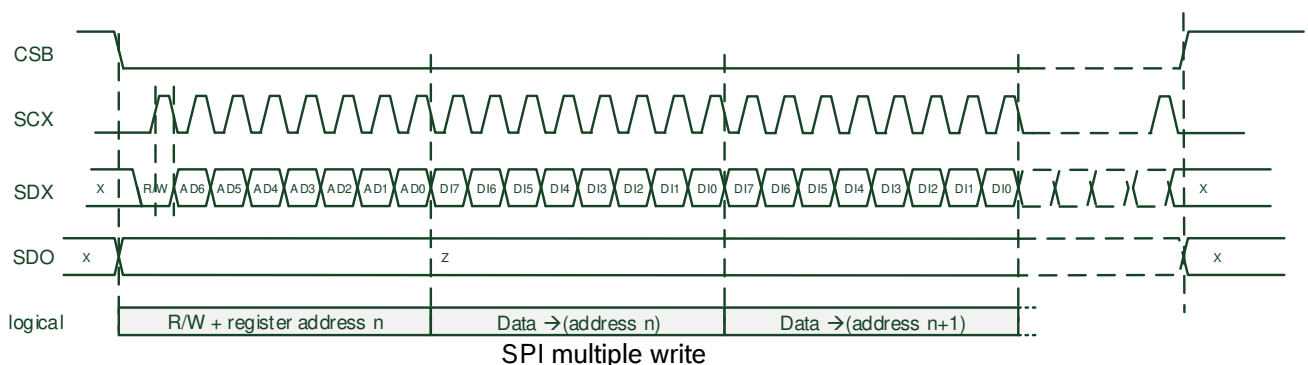

The basic read operation waveform for 4-wire configuration is depicted in the figure below. Please note that the first byte received from the device via the SDO line correspond to a dummy byte and the 2<sup>nd</sup> byte correspond to the value read out of the specified register address. That means, for a basic read operation two bytes have to be read and the first has to be dropped and the second byte must be interpreted.

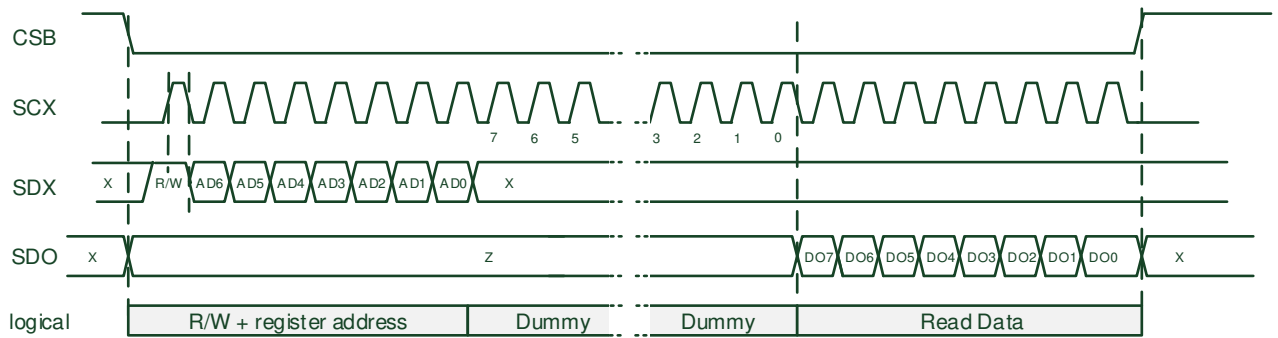

4-wire basic SPI read sequence (mode '00')

The data bits are used as follows:

R/W: Read/Write bit. When 0, the data SDI is written into the chip. When 1, the data SDO from the chip is read.

AD6-AD0: Register address

DI7-DI0: When in write mode, these are the data SDI, which will be written into the address.

DO7-DO0: When in read mode, these are the data SDO, which are read from the address.

Multiple read operations are possible by keeping CSB low and continuing the data transfer. Only the first register address has to be written. Addresses are automatically incremented after each read access as long as CSB stays active low. Please note that the first byte received from the device via the SDO line corresponds to a dummy byte and the 2<sup>nd</sup> byte corresponds to the value read out of the specified register address. The successive bytes read out correspond to values of incremented register addresses. That means, for a multiple read operation of n bytes, n+1 bytes have to be read, the first has to be dropped and the successive bytes must be interpreted.

**In SPI 3-wire configuration** CSB (chip select low active), SCX (as SCK for serial clock), and SDX (as SDA for serial data input and output) pins are used. While SCK is high, the communication starts when the CSB is pulled low by the SPI master and stops when CSB is pulled high. SCK is controlled by SPI master. SDI is driven (when used as input of the device) at the falling edge of SCK and should be captured (when used as the output of the device) at the rising edge of SCK.

The protocol as such is the same in 3-wire configuration as it is in 4-wire configuration. The basic operation for read and write access for 3-wire configuration is depicted in the figure below:

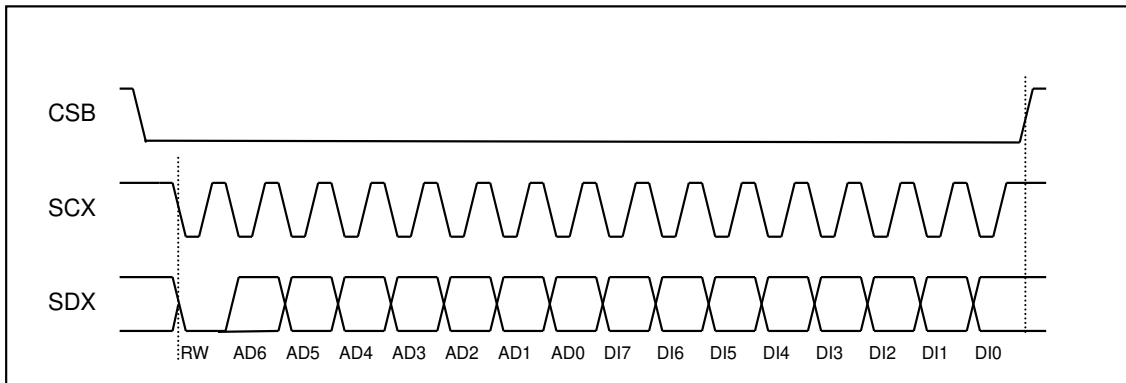

3-wire basic SPI write sequence (mode '11')

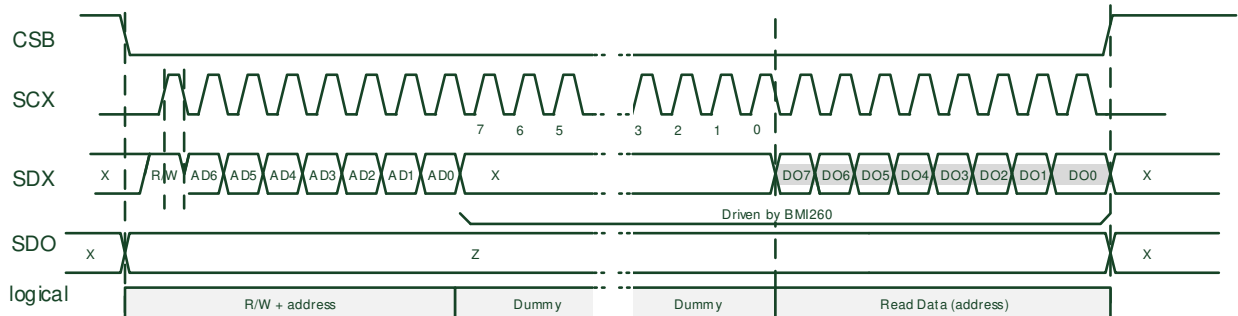

3-wire basic SPI read sequence (mode '00')

## 6.5. Primary Interface I<sup>2</sup>C

The I<sup>2</sup>C bus uses SCX (as SCL for serial clock) and SDX (as SDA for serial data input and output) signal lines. Both lines are connected to V<sub>DDIO</sub> externally via pull-up resistors so that they are pulled high when the bus is free.

The default I<sup>2</sup>C address of the device is 0b1101000 (0x68). It is used if the SDO pin is pulled to 'GND'. The alternative address 0b1101001 (0x69) is selected by pulling the SDO pin to 'VDDIO'.

The I<sup>2</sup>C interface of device is compatible with the I<sup>2</sup>C Specification UM10204 Rev. 03 (19 June 2007), available at <http://www.nxp.com>. The device supports I<sup>2</sup>C standard mode (100kHz), fast mode (40kHz) and fast mode plus (1000kHz). Only 7-bit address mode is supported. <http://www.nxp.com>. The device supports I<sup>2</sup>C standard mode (100kHz), fast mode (40kHz) and fast mode plus (1000kHz). Only 7-bit address mode is supported.

The device supports fast mode plus I<sup>2</sup>C mode that allows using clock frequencies up to 1 MHz. In this mode all timings of the fast mode apply and it additionally supports clock frequencies up to 1MHz.

The timing specification for I<sup>2</sup>C of the device is given in the following table:

Table 20: Timing specification for I<sup>2</sup>C of the device

PARAMETER	SYMBOL	CONDITION	MIN	MAX	UNITS
Clock Frequency	f <sub>SCL</sub>			1000	kHz
SCL Low Period	t <sub>LOW</sub>		1.3		μs
SCL High Period	t <sub>HIGH</sub>		0.6		
SDA Setup Time	t <sub>SUDAT</sub>		0.1		
SDA Hold Time	t <sub>HDDAT</sub>		0.0		
Setup Time for a repeated Start Condition	t <sub>SUSTA</sub>		0.6		
Hold Time for a Start Condition	t <sub>HDSTA</sub>		0.6		
Setup Time for a Stop Condition	t <sub>SUSTO</sub>		0.6		
Time before a new Transmission can start	t <sub>BUF</sub>	low power mode	400		
		normal mode	1.3		
Idle time between write accesses in normal mode, fast startup mode	t <sub>IDLE_wacc_nm</sub>		2		
Idle time between write accesses in suspend mode, low-power mode	t <sub>IDLE_wacc_su_m</sub>		450		

The figure below shows the definition of the I<sup>2</sup>C timings given in the above table:

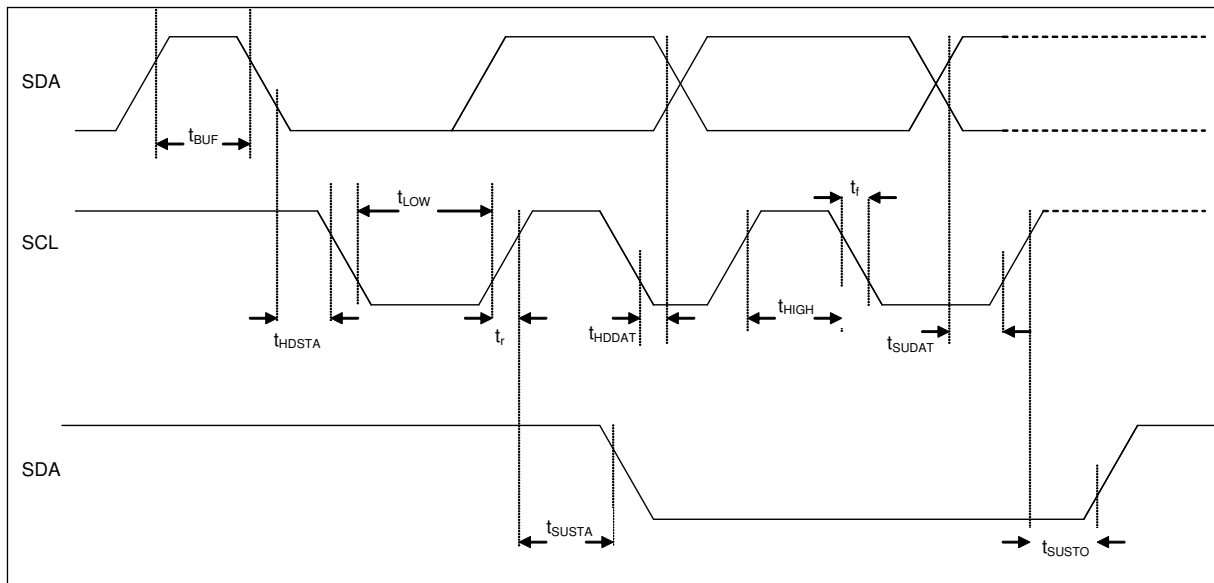

Figure 11: I<sup>2</sup>C timing diagram

The I<sup>2</sup>C protocol works as follows:

**START:** Data transmission on the bus begins with a high to low transition on the SDA line while SCL is held high (start condition (S) indicated by I<sup>2</sup>C bus master). Once the START signal is transferred by the master, the bus is considered busy.

**STOP:** Each data transfer should be terminated by a Stop signal (P) generated by master. The STOP condition is a low to high transition on SDA line while SCL is held high.

**ACKS:** Each byte of data transferred must be acknowledged. It is indicated by an acknowledge bit sent by the receiver. The transmitter must release the SDA line (no pull down) during the acknowledge pulse while the receiver must then pull the SDA line low so that it remains stable low during the high period of the acknowledge clock cycle.

In the following diagrams these abbreviations are used:

S	Start
P	Stop
ACKS	Acknowledge by slave
ACKM	Acknowledge by master
NACKM	Not acknowledge by master
RW	Read / Write

A START immediately followed by a STOP (without SCL toggling from 'VDDIO' to 'GND') is not supported. If such a combination occurs, the STOP is not recognized by the device.

**I<sup>2</sup>C write access:**

I<sup>2</sup>C write access can be used to write a data byte in one sequence.

The sequence begins with start condition generated by the master, followed by 7 bits slave address and a write bit (RW = 0). The slave sends an acknowledge bit (ACKS = 0) and releases the bus. Then the master sends the one byte register address. The slave again acknowledges the transmission and waits for the 8 bits of data which shall be written to the specified register address. After the slave acknowledges the data byte, the master generates a stop signal and terminates the writing protocol.

Example of an I<sup>2</sup>C write access:

Start	Slave Address							R/W	ACK		Register address (0x41)							ACK	Register data (0x01)							ACK	Stop	
S	1	1	0	1	0	0	0	0	X		1	0	0	0	0	0	1	0	0	0	0	0	0	0	0	1	0	P

	Master -> Slave
	Slave -> Master

I<sup>2</sup>C write

Multi-byte writes are supported without restriction on normal registers with auto-increment as well as on special registers with address trap.

**I<sup>2</sup>C read access:**

I<sup>2</sup>C read access can be used to read one or multiple data bytes in one sequence.

A read sequence consists of a one-byte I<sup>2</sup>C write phase followed by the I<sup>2</sup>C read phase. The two parts of the transmission must be separated by a repeated start condition (S). The I<sup>2</sup>C write phase addresses the slave and sends the register address to be read. After slave acknowledges the transmission, the master generates again a start condition and sends the slave address together with a read bit (RW = 1). Then the master releases the bus and waits for the data bytes to be read out from slave. After each data byte the master has to generate an acknowledge bit (ACKM = 0) to enable further data transfer. A NACKM (ACKM = 1) from the master stops the data being transferred from the slave. The slave releases the bus so that the master can generate a STOP condition and terminate the transmission.

The register address is automatically incremented and, therefore, more than one byte can be sequentially read out. Once a new data read transmission starts, the start address will be set to the register address specified since the latest I<sup>2</sup>C write command. By default the start address is set at 0x00. In this way repetitive multi-bytes reads from the same starting address are possible.



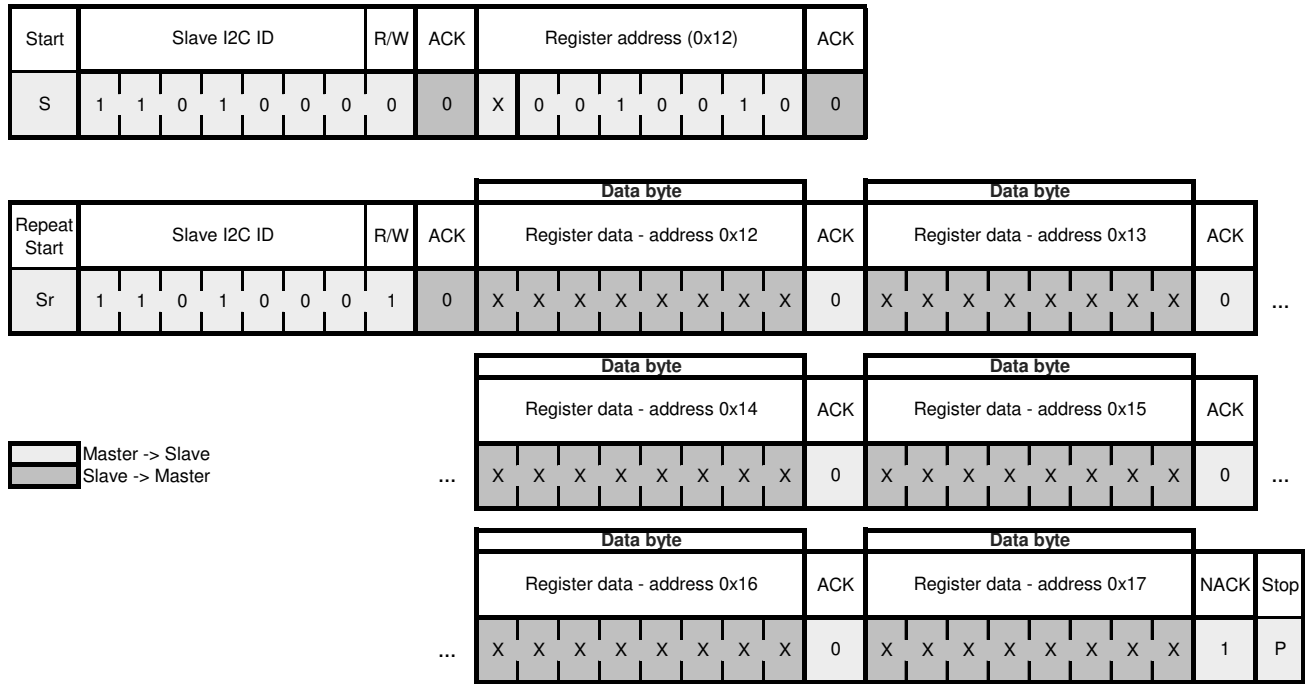

In order to prevent the I<sup>2</sup>C slave of the device to lock-up the I<sup>2</sup>C bus, a watchdog timer (WDT) is implemented. The WDT observes internal I<sup>2</sup>C signals and resets the I<sup>2</sup>C interface if the bus is locked-up by the device. The activity and the timer period of the WDT can be configured through the bits [NV\\_CONF.i2c\\_wdt\\_en](#) and [NV\\_CONF.i2c\\_wdt\\_sel](#).

#### SPI and I<sup>2</sup>C Access Restrictions

In order to allow for the correct internal synchronization of data written to the device, certain access restrictions apply for consecutive write accesses or a write/read sequence through the SPI as well as I<sup>2</sup>C interface. The required waiting period depends on whether the device is operating in normal mode or other modes.

As illustrated in the figure below, an interface idle time of at least 2 μs is required following a write operation when the device operates in normal mode. In suspend mode an interface idle time of at least 450 μs is required.

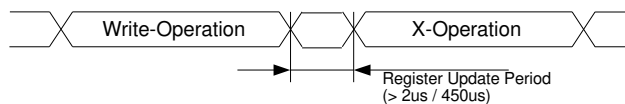

Post-Write Access Timing Constraints

## 6.6. Secondary Interface

The secondary interface can be used in either of the following two configurations:

- Auxiliary interface (I2C master) for connecting an external sensor:  
In this case, the secondary interface is used as a two-wire I2C interface (ASDX and ASCX pins) where an external sensor like a magnetometer can be connected as a slave to the device. Typical application is connecting a Bosch Sensortec geomagnetic sensor like BMM150.
- OIS interface (SPI slave) for connecting to OIS control unit  
In this case, the secondary interface is used as an SPI interface where an external controller can be connected as a master to the device. External controller can be an OIS control unit.

The mapping of the device pins for secondary interface usage is given in following table:

Table 21: Mapping of the device pins for secondary interface

PIN #	NAME	I/O TYPE	DESCRIPTION	CONNECTION TO SECONDARY INTERFACE		
				OIS SPI 4w	OIS SPI 3w	AUXILIARY I2C
2	ASDX	Digital I/O	Aux interface / OIS interface	SDI	SDA	SDA
3	ASCX	Digital I/O	Aux interface / OIS interface	SCK	SCK	SCL
10	OCSB	Digital in	OIS interface	CSB	CSB	DNC
11	OSDO	Digital out	OIS interface	SDO	DNC	DNC

### Auxiliary Interface

The device allows attaching an external sensor (e.g. magnetometer) to the secondary interface. The connection diagrams for the auxiliary interface are depicted in the section 7.3. The timings of the secondary I2C interface are the same as for the primary I2C interface, see section 6.5.

The device acts as a master of the secondary interface, controls the data acquisition of the external sensor (slave of the secondary interface) and presents the data to the application processor (AP) in the user registers of the device through the primary interface. No external pull-up resistors need to be connected, since an internal pull-up register can be configured through [AUX\\_IF\\_TRIM.asda\\_pupsel](#). No additional I2C master or slave devices can be attached to the magnetometer interfaces.

The device autonomously reads out the sensor data from the external sensor without intervention of the application processor and stores the data in its data registers (per default) and FIFO (see Register [FIFO\\_CONFIG\\_1.fifo\\_aux\\_en](#)). The initial setup of the external sensor after power-on is done through indirect addressing in the device.

For more information about the usage of auxiliary interface see Section 4.10.

## OIS Interface

The device can support optical image stabilization (OIS) applications with the secondary interface (SPI only). The OIS controller has direct access to pre-filtered gyroscope and accelerometer data with minimum latency. Pre-filter gyroscope data is available at ODR of 6.4kHz and accelerometer data with ODR 1.6kHz. OIS SPI interface supports 3-wire and 4-wire modes. The timing of OIS SPI interface is identical to the primary SPI interface described in section 6.4

For more information about the usage of the OIS data see Section 4.11.

## 7. Pinout and Connection Diagram

### 7.1. Pin-out

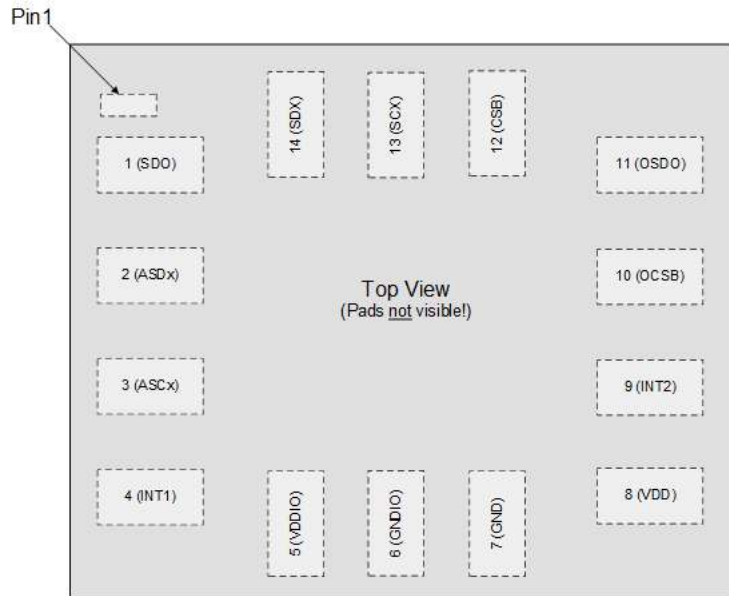

Pin-out top view

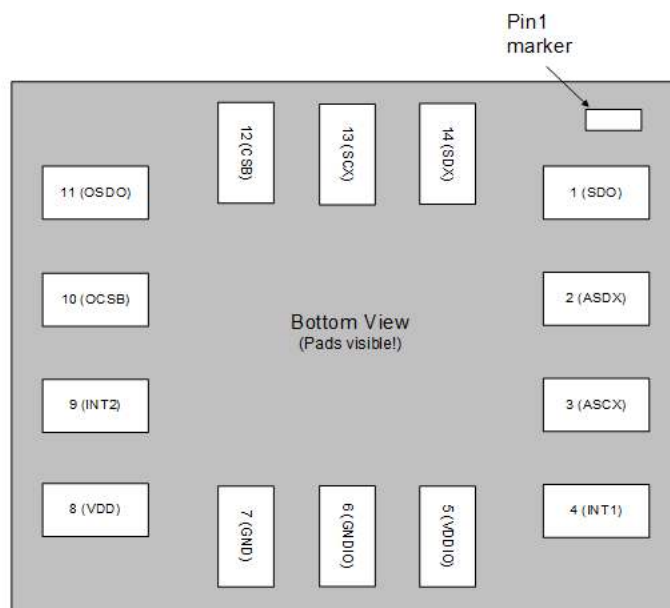

Pin-out bottom view

Table 22: Pin-out and pin connections

IN#	NAME	I/O TYPE	INTERFACE	DESCRIPTION	CONNECT TO		
					IN SPI 4W	IN SPI 3W	IN I2C
1	SDO	Digital I/O	Primary	SDO Serial data output in SPI 4W I2C Address bit-0 select in I2C mode	SDO	DNC	GND for default I2C address
2	ASDx	Digital I/O	Secondary	Aux interface / OIS interface**	VDDIO or DNC or Aux SDA or OIS SDI	VDDIO or DNC or Aux SDA or OIS SDI	VDDIO or DNC or Aux SDA or OIS SDI
3	ASCx	Digital I/O	Secondary	Aux interface / OIS interface**	VDDIO or DNC or Aux SCL or OIS SCK	VDDIO or DNC or Aux SCL or OIS SCK	VDDIO or DNC or Aux SCL or OIS SCK
4	INT1	Digital I/O	-	Interrupt pin 1*	INT1	INT1	INT1
5	VDDIO	Supply	-	Digital I/O supply voltage (1.2 ... 3.6V)	VDDIO	VDDIO	VDDIO
6	GNDIO	Ground	-	Ground for I/O	GNDIO	GNDIO	GNDIO
7	GND	Ground	-	Ground for digital & analog	GND	GND	GND
8	VDD	Supply	-	Power supply analog & digital domain (1.71V – 3.6V)	VDD	VDD	VDD
9	INT2	Digital I/O	-	Interrupt pin 2 *	INT2	INT2	INT2
10	OCSB	Digital in	Secondary	OIS interface	DNC*** or OIS CSB	DNC*** or OIS CSB	DNC*** or OIS CSB
11	OSDO	Digital out	Secondary	OIS interface	DNC*** or OIS SDO	DNC*** or OIS SDO	DNC*** or OIS SDO
12	CSB	Digital in	Primary	Chip select for SPI mode	CSB	CSB	VDDIO****
13	SCx	Digital in	Primary	SCK for SPI serial clock	SCK	SCK	SCL

				SCL for I <sup>2</sup> C serial clock			
14	SDx	Digital I/O	Primary	SDA serial data I/O in I2C SDI serial data input in SPI 4W SDA serial data I/O in SPI 3W	SDI	SDIO	SDA

\*) If INT1 and/or INT2 are not used, please do not connect them (DNC). INT1 and/or INT2 can also be configured as input in case the external data synchronization of FIFO is used.

\*\*\*) If secondary interface is unused, ASDX and ASCX can be connected to VDDIO or left unconnected. Do not connect to GND.

\*\*\*\*) Can be tied to GND only if register [IF\\_CONF.ois\\_en](#) = 0

\*\*\*\*\*) DNC is not recommended, but possible, if the system design ensures that the voltage never drops below VIH (internal pull-up available).

### 7.2. Connection Diagrams without Secondary Interface

It is recommended to use 100nF decoupling capacitors at pin 5 (VDDIO) and pin 8 (VDD).

**Primary: 3-wire SPI    Secondary: None**

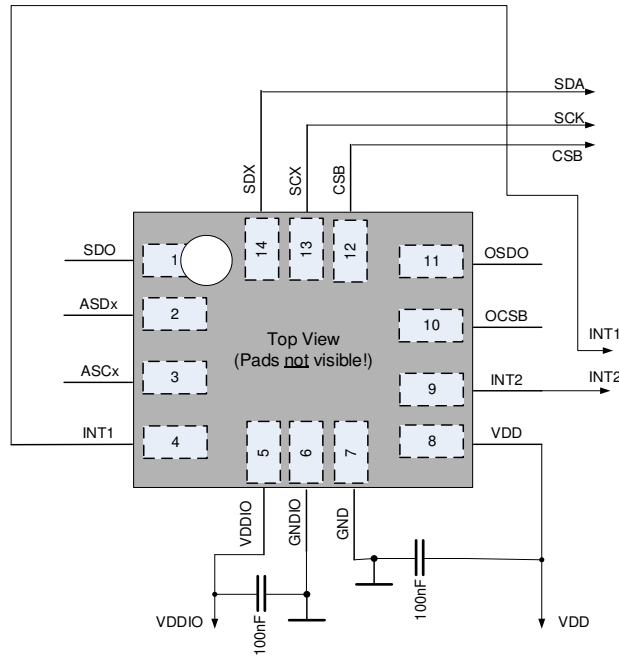

**Primary: 4-wire SPI    Secondary: None**

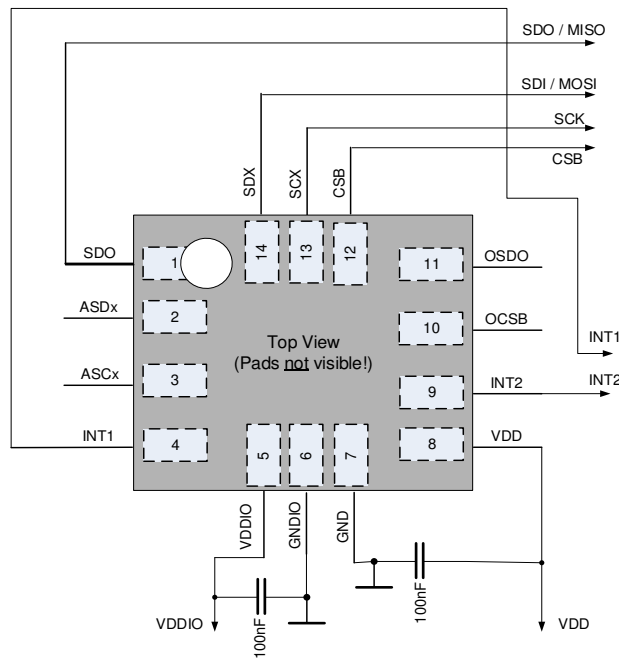

Primary: I2C Secondary: None

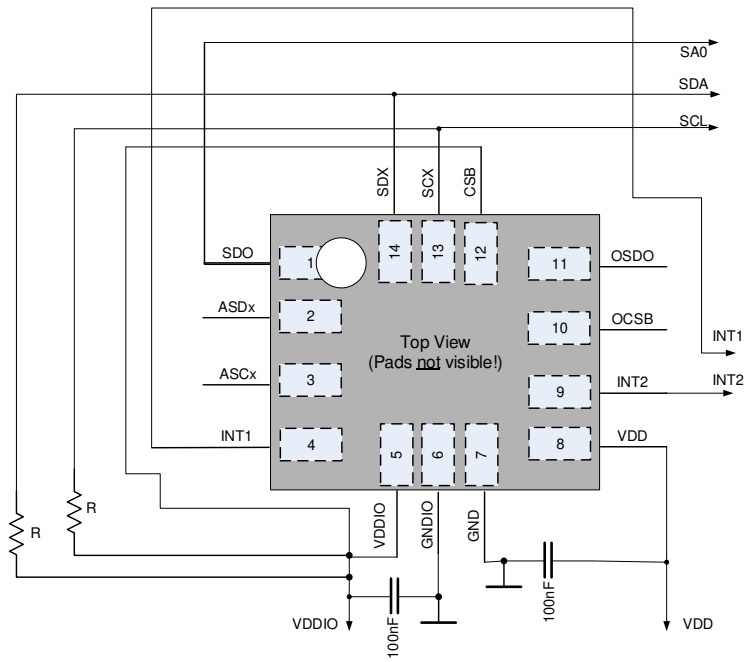

Here SA0 = I2C slave address bit-0 select



### 7.3. Connection Diagrams with I2C Auxiliary Interface

It is recommended to use 100nF decoupling capacitors at pin 5 (VDDIO) and pin 8 (VDD).

**Primary: 3-wire SPI    Secondary: Auxiliary interface I2C (e.g. BMM150 sensor)**

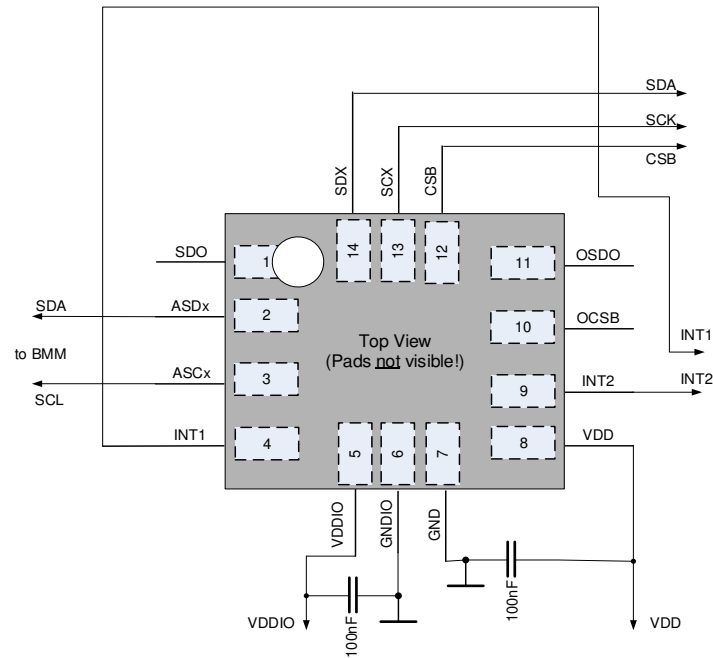

**Primary: 4-wire SPI    Secondary: Auxiliary interface I2C (e.g. BMM150 sensor)**

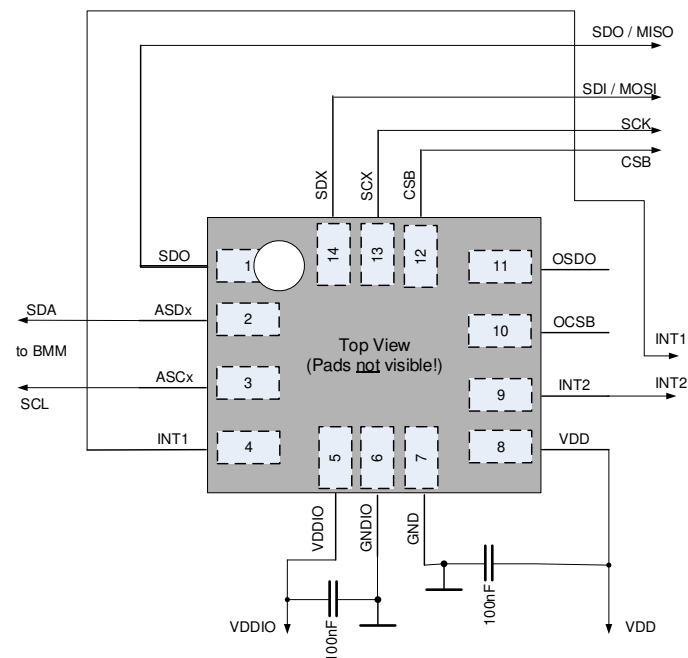

**Primary: I2C    Secondary: Auxiliary interface I2C (e.g. BMM150 sensor)**

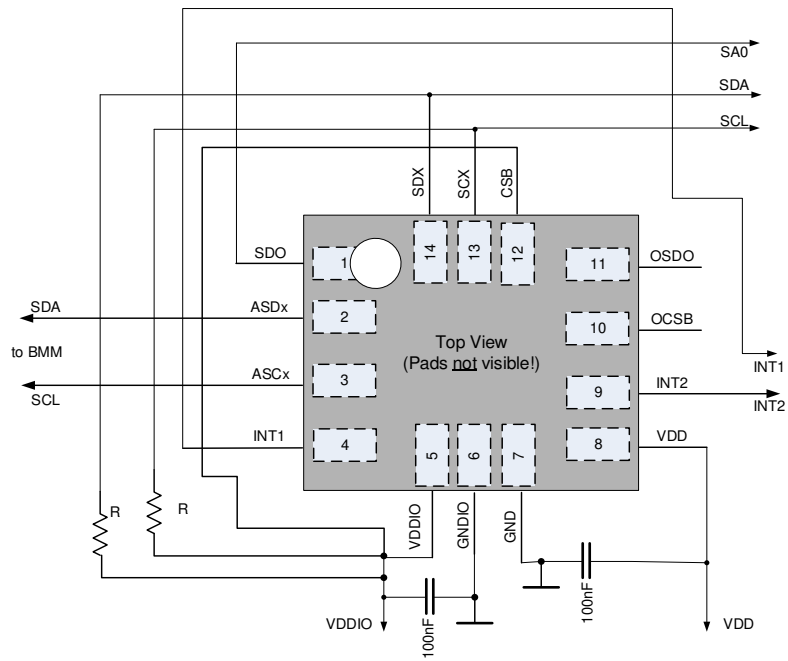

### 7.4. Connection Diagrams with OIS Interface

It is recommended to use 100nF decoupling capacitors at pin 5 (VDDIO) and pin 8 (VDD).

#### Primary: 3-wire SPI Secondary: 4-wire SPI for OIS interface

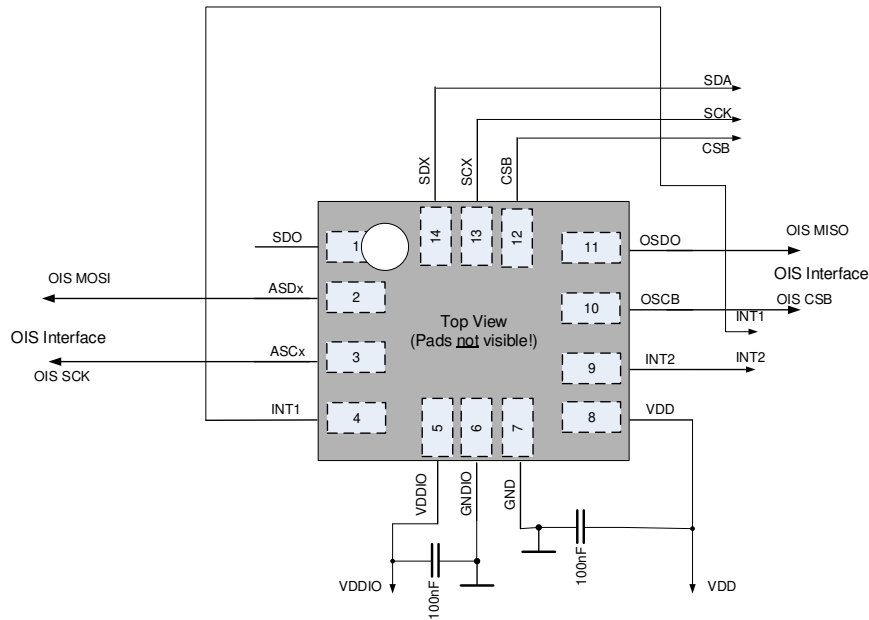

#### Primary: 3-wire SPI Secondary: 3-wire SPI for OIS interface

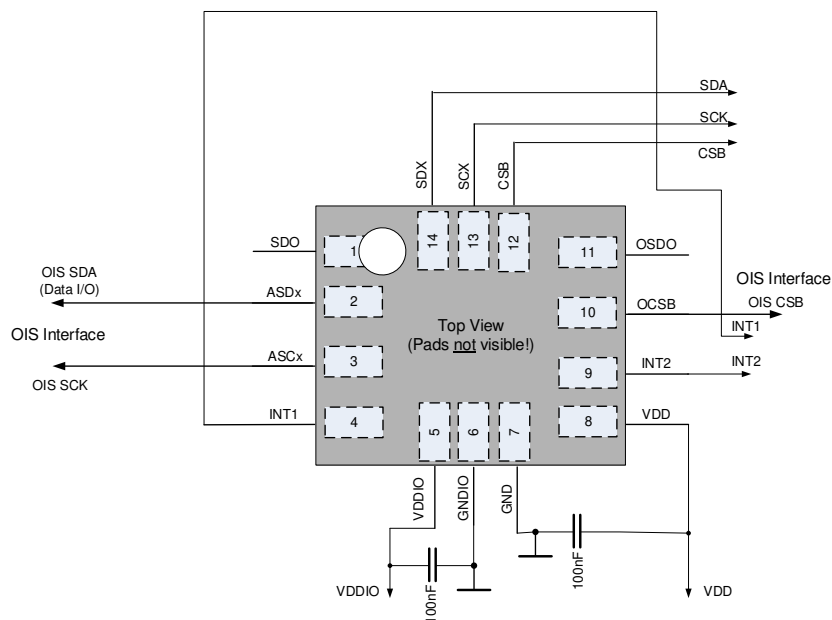

**Primary: 4-wire SPI Secondary: 4-wire SPI for OIS interface**

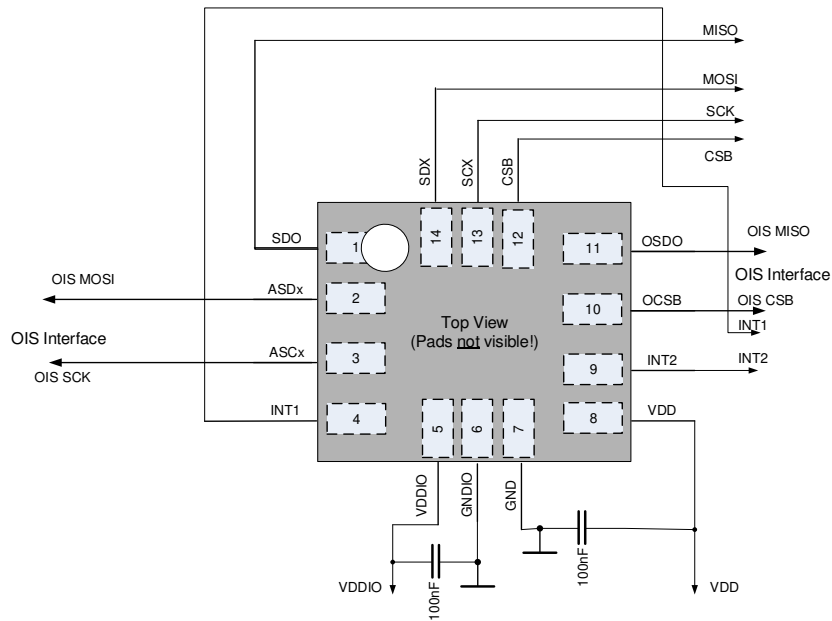

**Primary: 4-wire SPI Secondary: 3-wire SPI for OIS interface**

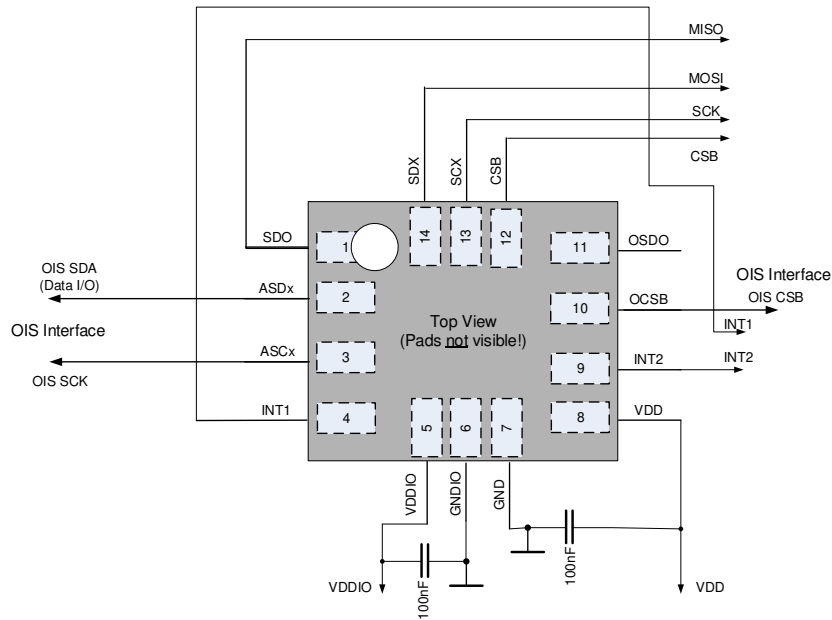

**Primary: I2C Secondary: 4-wire SPI for OIS interface**

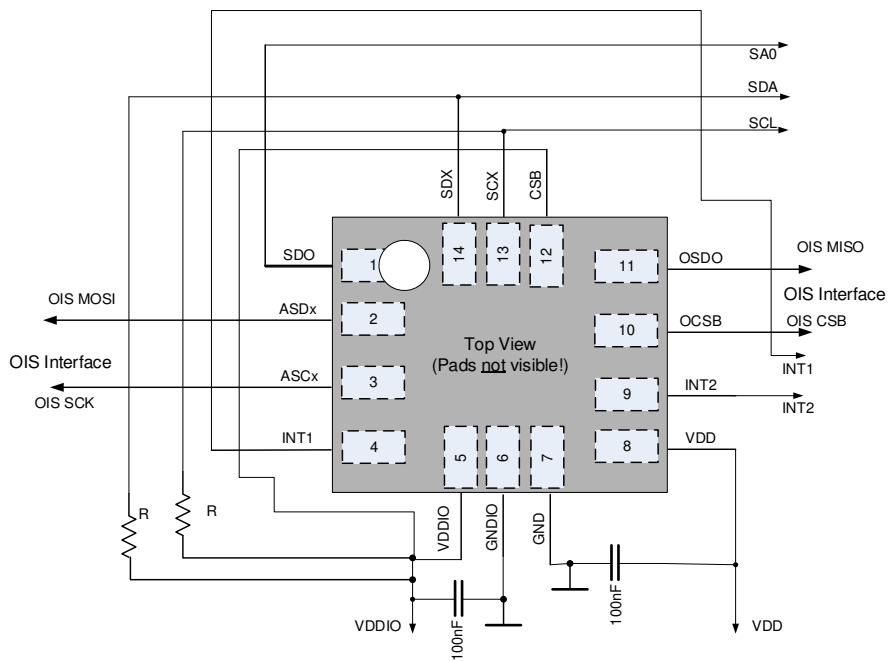

**Primary: I2C Secondary: 3-wire SPI for OIS interface**

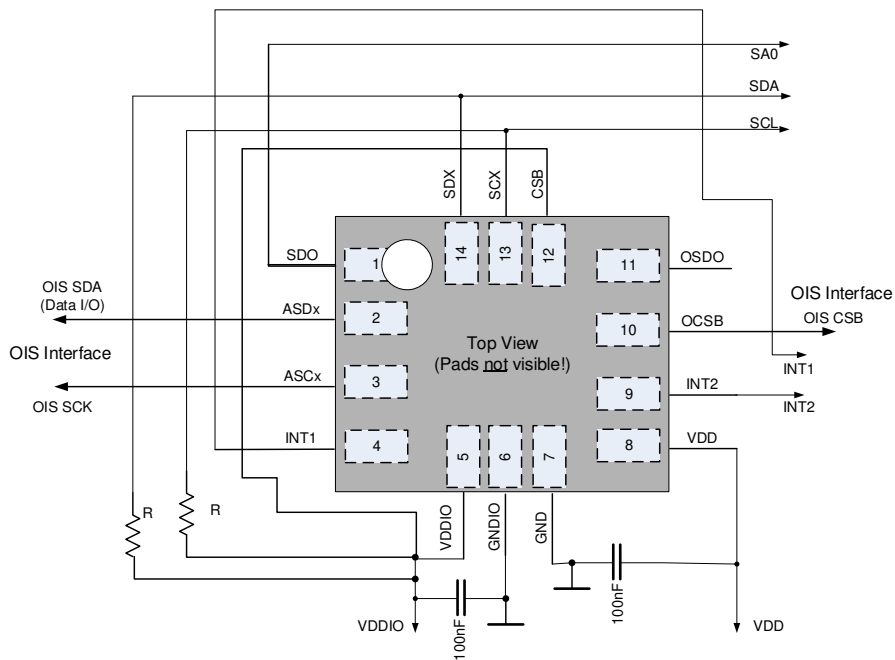

## 8. Package

### 8.1. Package outline dimensions

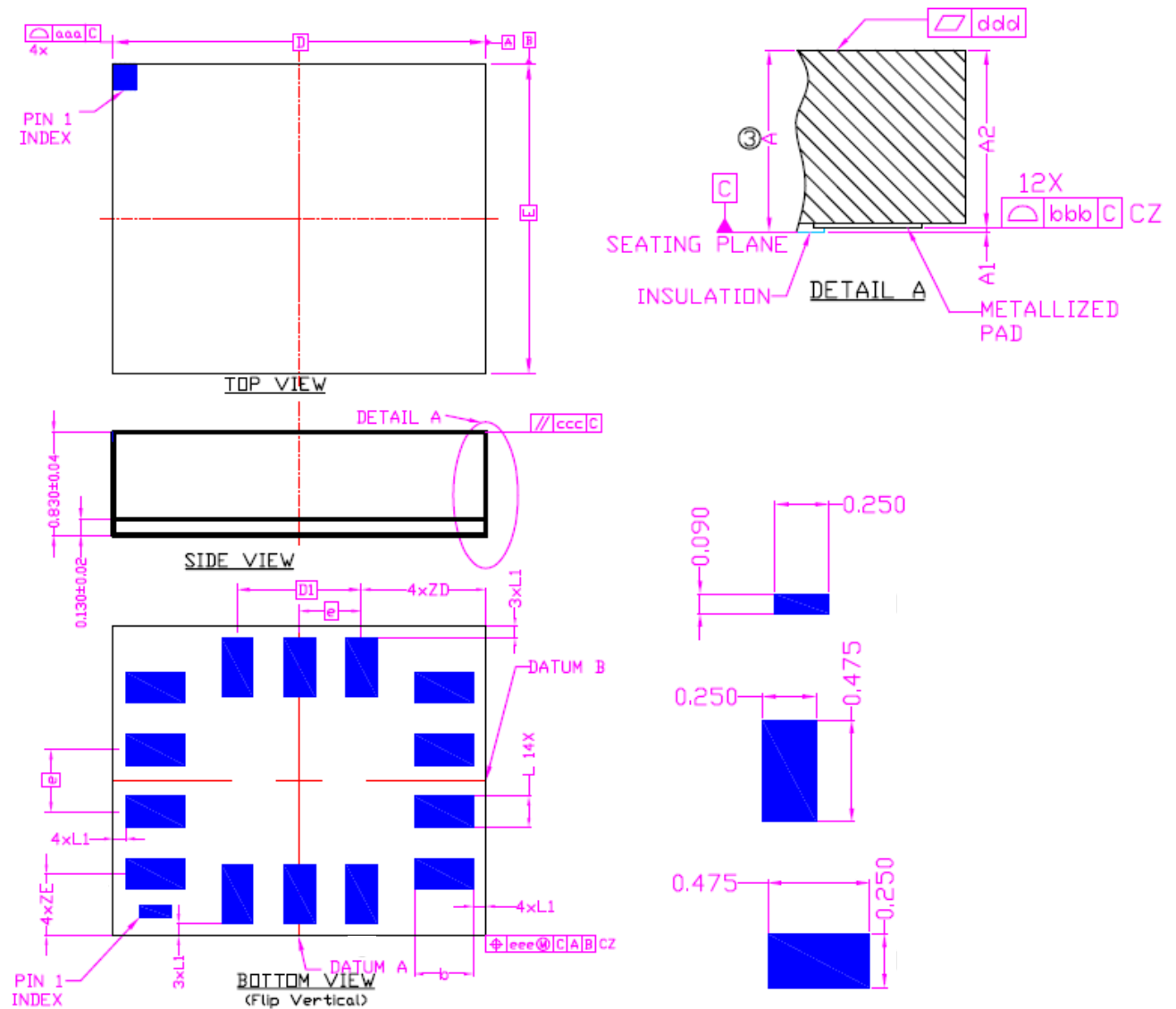

DIMENSIONAL REFERENCES				unit: mm
REF.	Min.	Nom.	Max.	
A	0.79	0.83	0.87	
A1	0.11	0.13	0.15	
A2	0.68	0.70	0.72	
b	Refer to metallized pad detail			
D	2.95	3.00	3.05	
E	2.45	2.50	2.55	
D1	1.00 BSC			
ZD	1.00 BSC			
ZE	0.50 BSC			
e	0.50 BSC			
L1	0.074	0.100	-	

DIMENSIONAL REFERENCES		unit: mm
REF.	TOLERANCE OF FORM AND POSITION	
aaa	0.050	
bbb	0.050	
ccc	0.100	
ddd	0.020	
eee	0.056	
xxx	-	

Notes :

- ① 'e' REPRESENTS THE BASIC TERMINAL PITCH. SPECIFIES THE TRUE GEOMETRIC POSITION OF THE TERMINAL AXIS.
- ② DIMENSION 'b' APPLIES TO METALLIZED TERMINAL PAD.
- ③ DIMENSION 'A' INCLUDES PACKAGE WARPAGE.
- ④ EXPOSED METALLIZED PADS ARE CU PADS WITH SURFACE FINISH PROTECTION.
- ⑤ TOP PACKAGE SURFACE ROUGHNESS IS Ra 1~3µm.

## 8.2. Sensing axis orientation

If the sensor is accelerated and/or rotated in the indicated directions, the corresponding channels of the device will deliver a positive acceleration and/or yaw rate signal (dynamic acceleration). If the sensor is at rest without any rotation and the force of gravity is acting contrary to the indicated directions, the output of the corresponding acceleration channel will be positive and the corresponding gyroscope channel will be “zero” (static acceleration).



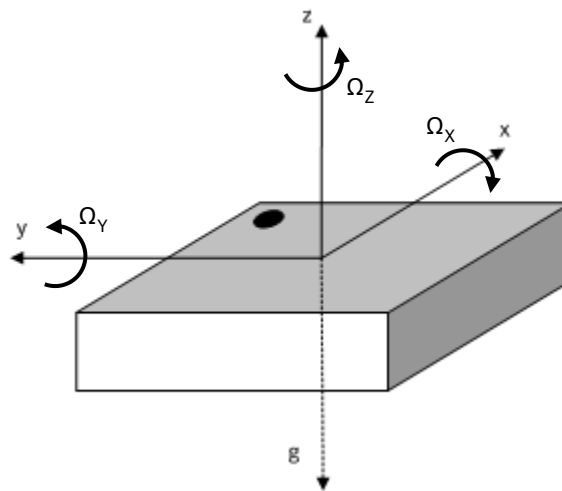

Example: If the sensor is at rest or at uniform motion in a gravity field according to the figure given below, the output signals are:

- $\pm 0g$  for the X ACC channel and  $\pm 0^\circ/\text{sec}$  for the  $\Omega_x$  GYR channel
- $\pm 0g$  for the Y ACC channel and  $\pm 0^\circ/\text{sec}$  for the  $\Omega_y$  GYR channel
- $+ 1g$  for the Z ACC channel and  $\pm 0^\circ/\text{sec}$  for the  $\Omega_z$  GYR channel

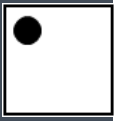

Definition of sensing axes orientation

The following table lists all corresponding output signals on X, Y, and Z while the sensor is at rest or at uniform motion in a gravity field under assumption of a  $\pm 4g$  range setting, a 16 bit resolution, and a top down gravity vector as shown above.

Sensor Orientation (gravity vector ↓)						
Output Signal X	0g/0 LSB	1g/8192 LSB	0g/0 LSB	-1g/-8192 LSB	0g/0 LSB	0g/0 LSB
Output Signal Y	-1g/-8192 LSB	0g/0 LSB	1g/8192 LSB	0g/0 LSB	0g/0 LSB	0g/0 LSB
Output Signal Z	0g/0 LSB	0g/0 LSB	0g/0 LSB	0g/0 LSB	1g/8192 LSB	-1g/-8192 LSB

If the sensor axes coordinates do not match the platforms axes coordinates, then axis remapping is required. For the accelerometer and gyroscope data, the axes remapping needs to be implemented in the applications processor’s driver. For the interrupt features to work properly, axes remapping information must be written to configuration registers of the device. Axes remapping is supported via most interrupt features in a configuration registers, which applies to the feature algorithms.



### 8.3. Landing pattern recommendation

The following landing pad recommendation is given for maximum stability of the solder connections.

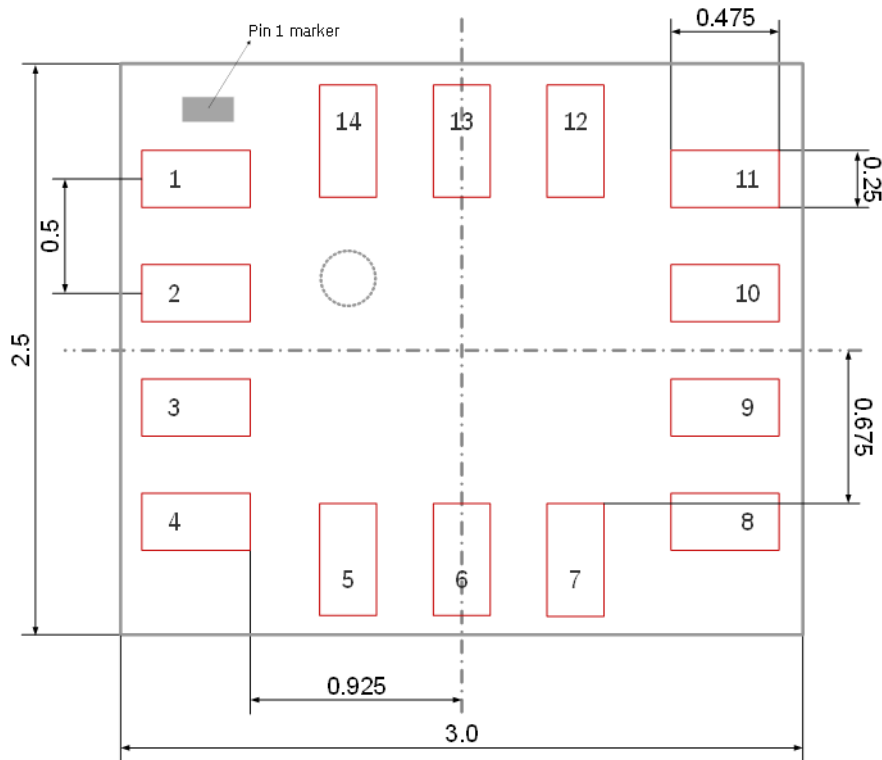

## 8.4. Marking

### Mass production

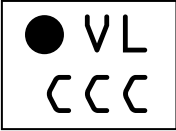
Labeling	Name	Symbol	Remark
	Internal Code	L	1 alphanumeric digit, fixed, L ≠ "E" L = "P" or "L" or "W" or "N", internal use
	Product Identifier	V	1 alphanumeric digit, fixed, V = "5" to identify BMI2xy product family
	Counter ID	CCC	3 alphanumeric digits, variable to generate trace-code
	Pin 1 identifier top side	●	--

### Engineering samples

Labeling	Name	Symbol	Remark
	Eng. sample ID	L, N	2 alphanumeric digit, fixed, L = "E" to identify engineering sample, N = "L" or "C"
	Product Identifier	V	1 alphanumeric digit, fixed, V = "P" or "L" or "W" or "N"
	Counter ID	CC	2 alphanumeric digits, variable Internal revision ID to identify BMI2xy product family
	Pin 1 identifier top side	●	--

## 8.5. Soldering guidelines

The moisture sensitivity level of the device corresponds to JEDEC Level 1, see also:

- IPC/JEDEC J-STD-020E "Joint Industry Standard: Moisture/Reflow Sensitivity Classification for non-hermetic Solid State Surface Mount Devices"
- IPC/JEDEC J-STD-033D "Joint Industry Standard: Handling, Packing, Shipping and Use of Moisture/Reflow Sensitive Surface Mount Devices"

Both documents are available on [JEDEC's Website](#)

The sensor fulfils the lead-free soldering requirements of the above-mentioned IPC/JEDEC standard, i.e. reflow soldering with a peak temperature  $T_p$  up to 260°C.

## 8.6. Handling instructions

Micromechanical sensors are designed to sense acceleration with high accuracy even at low amplitudes and contain highly sensitive structures inside the sensor element. The MEMS sensor can tolerate mechanical shocks up to several thousand g's. However, these limits might be exceeded in conditions with extreme shock loads such as e.g. hammer blow on or next to the sensor, dropping of the sensor onto hard surfaces etc.

We recommend to avoid g-forces beyond the specified limits during transport, handling and mounting of the sensors in a defined and qualified installation process.

This device has built-in protections against high electrostatic discharges or electric fields (e.g. 2kV HBM); however, anti-static precautions should be taken as for any other CMOS component. Unless otherwise specified, proper operation can only occur when all terminal voltages are kept within the supply voltage range. Unused inputs must always be tied to a defined logic voltage level.

## 8.7. Environmental safety

The device meets the requirements of the EC restriction of hazardous substances (RoHS) directive, see also:

*RoHS – Directive 2011/65/EU and its amendments, including the amendment 2015/863/EU on the restriction of the use of certain hazardous substances in electrical and electronic equipment.*

### Halogen content

The device is halogen-free. For more details on the corresponding analysis results please contact your Bosch Sensortec representative.

### Internal package structure

Within the scope of Bosch Sensortec's ambition to improve its products and secure the mass product supply, Bosch Sensortec qualifies additional sources (e.g. 2<sup>nd</sup> source) for the LGA package of the device.

While Bosch Sensortec took care that all of the package parameters as described above are 100% identical for all sources, there can be differences in the chemical content and the internal structure between the different package sources.

However, as secured by the extensive product qualification process of Bosch Sensortec, this has no impact to the usage or to the quality of the device.

## 9. Legal disclaimer

### 9.1. Engineering samples

Engineering Samples are marked with an asterisk (\*) or (e). Samples may vary from the valid technical specifications of the product series contained in this data sheet. They are therefore not intended or fit for resale to third parties or for use in end products. Their sole purpose is internal client testing. The testing of an engineering sample may in no way replace the testing of a product series. Bosch Sensortec assumes no liability for the use of engineering samples. The Purchaser shall indemnify Bosch Sensortec from all claims arising from the use of engineering samples.

### 9.2. Product use

Bosch Sensortec products are developed for the consumer goods industry. They may only be used within the parameters of this product data sheet. They are not fit for use in life-sustaining or safety-critical systems. Safety-critical systems are those for which a malfunction is expected to lead to bodily harm, death or severe property damage. In addition, they shall not be used directly or indirectly for military purposes (including but not limited to nuclear, chemical or biological proliferation of weapons or development of missile technology), nuclear power, deep sea or space applications (including but not limited to satellite technology).

The resale and/or use of Bosch Sensortec products are at the purchaser's own risk and his own responsibility. The examination of fitness for the intended use is the sole responsibility of the purchaser.

The purchaser shall indemnify Bosch Sensortec from all third party claims arising from any product use not covered by the parameters of this product data sheet or not approved by Bosch Sensortec and reimburse Bosch Sensortec for all costs in connection with such claims.

The purchaser accepts the responsibility to monitor the market for the purchased products, particularly with regard to product safety, and to inform Bosch Sensortec without delay of all safety-critical incidents.

### 9.3. Application examples and hints

With respect to any examples or hints given herein, any typical values stated herein and/or any information regarding the application of the device, Bosch Sensortec hereby disclaims any and all warranties and liabilities of any kind, including without limitation warranties of non-infringement of intellectual property rights or copyrights of any third party. The information given in this document shall in no event be regarded as a guarantee of conditions or characteristics. They are provided for illustrative purposes only and no evaluation regarding infringement of intellectual property rights or copyrights or regarding functionality, performance or error has been made.

## 10. Document history and modifications

Rev. No	Chapter	Description of modification/changes	Date
0.9	-	Preliminary version	29-Feb-2019
1.0	6.5	Typo	17-May-2019
1.1	Basic Description 1 3.1.b 4.4 4.5 4.6 4.7 4.12 4.13 4.17 5.1 6.2, 7.1 6.4 8.1 8.4 8.5, 8.7 9	Updated description Updated Accel only normal mode current consumption, power on time, Gyro PSR Updated initialization sequence wait time Corrected typos in wait time Updated Power Modes table Updated Gyro CAS data post processing description Updated frame rates description (FIFO) Updated accelerometer self-test range Updated offset resolution for gyro Updated soft-reset timing constraints Updated clear-on-read registers Updated Pin 12 description (table 17, 22) Updated timing specifications for SPI (table 19) Updated package dimensions drawing (detailed) Updated MP Marking (internal code) Updated references Updated legal disclaimer	04-May-2020
1.2	2 8.1	Updated absolute max. rating for MM Erased redundant information	25-June-2020

**Bosch Sensortec GmbH**

Gerhard-Kindler-Straße 9  
72770 Reutlingen / Germany

[contact@bosch-sensortec.com](mailto:contact@bosch-sensortec.com)  
[www.bosch-sensortec.com](http://www.bosch-sensortec.com)

Modifications reserved  
Specifications subject to change without notice  
Document number: BST-BMI270-DS000-04  
Revision\_1.2\_062020