

PART NO.	BASE TYPE	DESIGN VOLTS	DESIGN WATTS	DESIGN AMPS	MSCP	FILAMENT TYPE	AVERAGE LIFE HOURS
XPR19	S.C. MINIATURE FLANGED P13.5s	19.2	11.52	0.60 ±10%	13.8 ±15%	C-2V	150

REVISIONS			
REV	DESCRIPTION	DATE	APPROVED
1	ISSUED	04/25/2008	S.L.
2	REVISED AMP, MSCP, FILAMENT, LIFE	07/11/2012	D.C.

RoHS COMPLIANT
LEAD FREE

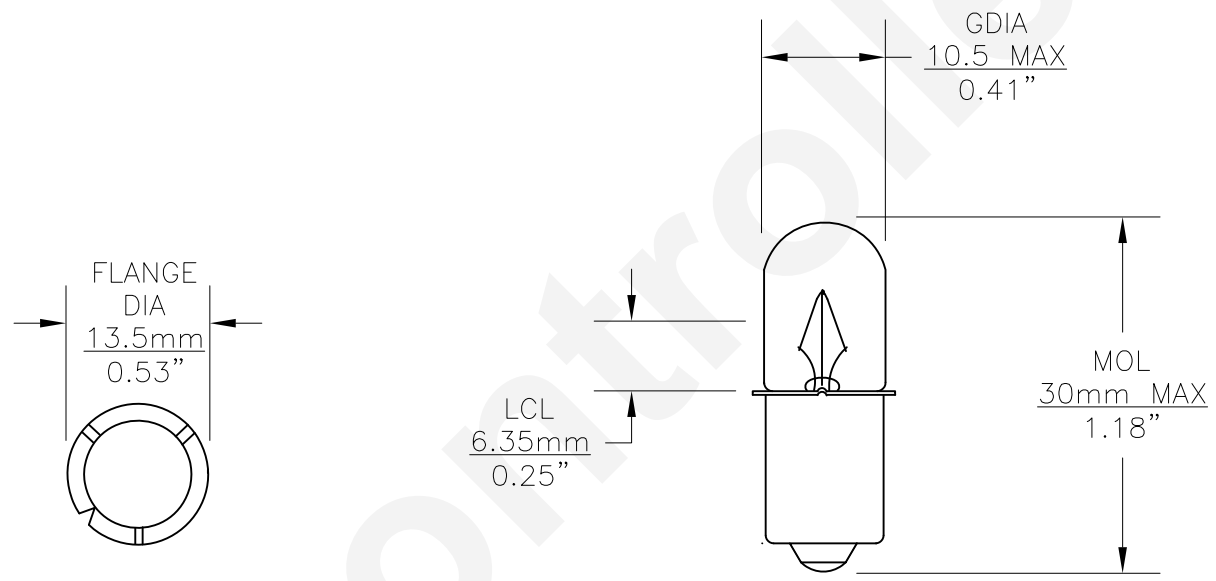

TOP VIEW

UNLESS OTHERWISE SPECIFIED: DIMENSIONS ARE IN INCHES TOLERANCES		CEC INDUSTRIES LTD			
DECIMALS .XX ± .05		599 BOND STREET			
ANGULAR .XXX ± .010		LINCOLNSHIRE, IL 60069			
FRACTIONAL ±1/64		TITLE			
DRAWN S.L.		LIGHT BULB NO. XPR19, XENON			
DATE 04/25/2008		SIZE A		DWG NO. XPR19	
CHECKED		SCALE		REV 2	
DESIGN		PLOT SCALE		SHEET 1 OF 1	
MATERIAL		FILE XPR19.dwg		DO NOT SCALE DRAWING	