

Notification about the transfer of the semiconductor business

The semiconductor business of Panasonic Corporation was transferred on September 1, 2020 to Nuvoton Technology Corporation (hereinafter referred to as "Nuvoton"). Accordingly, Panasonic Semiconductor Solutions Co., Ltd. became under the umbrella of the Nuvoton Group, with the new name of Nuvoton Technology Corporation Japan (hereinafter referred to as "NTCJ").

In accordance with this transfer, semiconductor products will be handled as NTCJ-made products after September 1, 2020. However, such products will be continuously sold through Panasonic Corporation.

Publisher of this Document is NTCJ.

If you would find description "Panasonic" or "Panasonic semiconductor solutions", please replace it with NTCJ.

※ Except below description page

"Request for your special attention and precautions in using the technical information and semiconductors described in this book"

Nuvoton Technology Corporation Japan

9 x 9 Dots Matrix LED Driver IC

FEATURES

- 9 × 9 LED Matrix Driver
(Total LED that can be driven = 81)
- LED Selectable Maximum Current
- LED Music Synchronizing Function
- I²C interface (Standard Mode, Fast Mode and Fast Mode Plus)
(4 Slave address selectable)
- 24 pin Shrink Small Outline Package (SSOP Type)

DESCRIPTION

AN32183A is a 81 Dots Matrix LED Driver. It can drive up to 27 RGB LEDs.

APPLICATIONS

- Mobile, Wearable
- Smart Speaker
- PCs
- Game Consoles
- Home Appliances etc.

TYPICAL APPLICATION

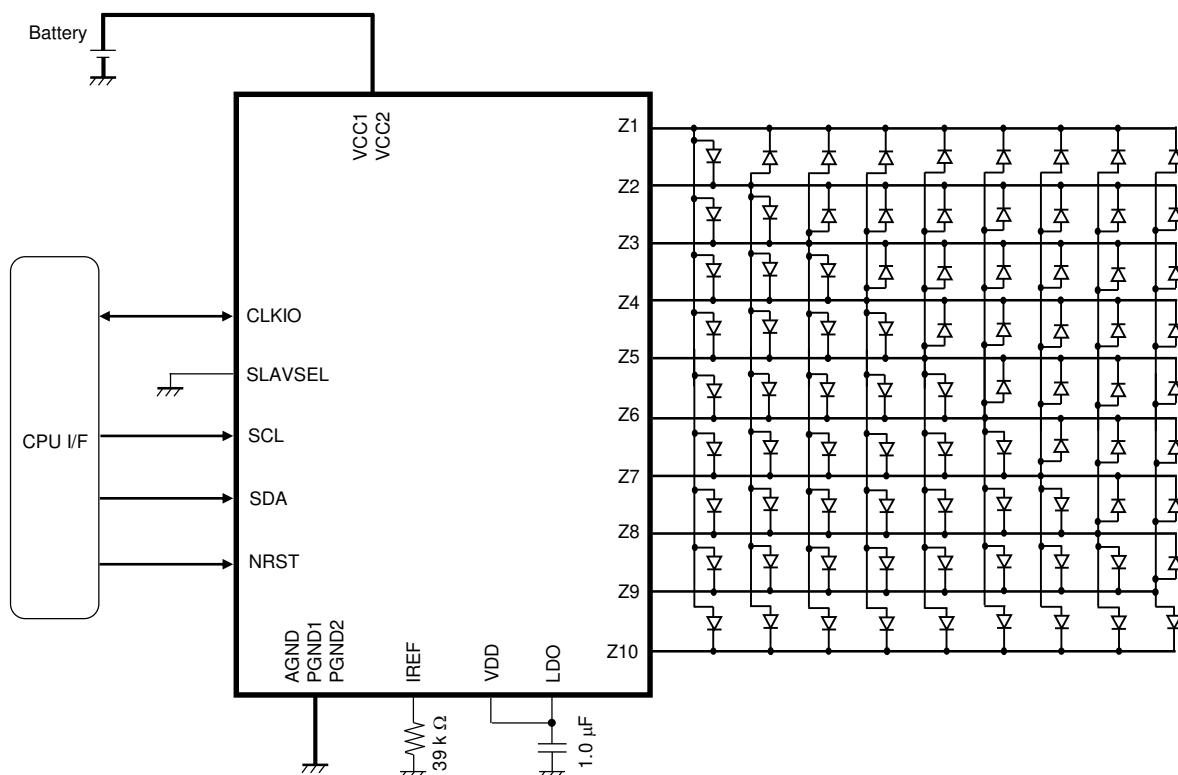

Note:

The application circuit is an example. The operation of the mass production set is not guaranteed. Sufficient evaluation and verification is required in the design of the mass production set. The Customer is fully responsible for the incorporation of the above illustrated application circuit in the design of the equipment.

CONTENTS

■ FEATURES	1
■ DESCRIPTION	1
■ APPLICATIONS	1
■ TYPICAL APPLICATION	1
■ CONTENTS	2
■ ORDERING INFORMATION	3
■ ABSOLUTE MAXIMUM RATINGS	3
■ POWER DISSIPATION RATING	3
■ RECOMMENDED OPERATING CONDITIONS	4
■ ELECTRICAL CHARACTERISTICS	5
■ PIN CONFIGURATION	11
■ PIN FUNCTIONS	12
■ FUNCTIONAL BLOCK DIAGRAM	13
■ OPERATION	15
■ PACKAGE INFORMATION	55
■ IMPORTANT NOTICE.....	56

ORDERING INFORMATION

Order Number	Feature	Package	Output Supply
AN32183A-VF	LED Driver for Illumination	24 pin SSOP	Emboss Taping

ABSOLUTE MAXIMUM RATINGS

Parameter	Symbol	Rating	Unit	Note
Supply voltage	$V_{CC_{MAX}}$	6.0	V	*1
	$V_{DD_{MAX}}$	6.0	V	*1
Operating ambience temperature	T_{opr}	- 30 to + 85	°C	*2
Operating junction temperature	T_j	- 30 to + 125	°C	*2
Storage temperature	T_{stg}	- 55 to + 125	°C	*2
Input Voltage Range	$V_{SLAVSEL}, V_{SCL}, V_{SDA},$ V_{CLKIO}, V_{NRST}	- 0.3 to 6.0	V	—
Output Voltage Range	$V_{LDO}, V_{CLKIO},$ $V_{Z1}, V_{Z2}, V_{Z3}, V_{Z4}, V_{Z5},$ $V_{Z6}, V_{Z7}, V_{Z8}, V_{Z9}, V_{Z10}$	- 0.3 to 6.0	V	—
ESD	HBM	2.0	kV	—

Note: This product may sustain permanent damage if subjected to conditions higher than the above stated absolute maximum rating. This rating is the maximum rating and device operating at this range is not guaranteed as it is higher than our stated recommended operating range. When subjected under the absolute maximum rating for a long time, the reliability of the product may be affected.

*1: $V_{CC_{MAX}} = V_{CC1} = V_{CC2}, V_{DD_{MAX}} = V_{DD}$.

The values under the condition not exceeding the above absolute maximum ratings and the power dissipation.

*2: Except for the power dissipation, operating ambient temperature, and storage temperature, all ratings are for $T_a = 25^\circ\text{C}$.

POWER DISSIPATION RATING

PACKAGE	θ_{JA}	$P_D (T_a=25^\circ\text{C})$	$P_D (T_a=85^\circ\text{C})$
24 pin Shrink Small Outline Package (SSOP Type)	135.1 °C /W	0.740 W	0.296 W

Note: For the actual usage, please refer to the P_D - T_a characteristics diagram in the package specification, follow the power supply voltage, load and ambient temperature conditions to ensure that there is enough margin and the thermal design does not exceed the allowable value.



CAUTION

Although this IC has built-in ESD protection circuit, it may still sustain permanent damage if not handled properly. Therefore, proper ESD precautions are recommended to avoid electrostatic damage to the MOS gates.

RECOMMENDED OPERATING CONDITIONS

Parameter	Symbol	Min.	Typ.	Max.	Unit	Note
Supply voltage range	V_{CC}	3.1	3.6	5.5	V	*1
	V_{DD}	1.7	1.85	5.5	V	*1
Input Voltage Range	$V_{SLAVSEL}, V_{SCL}, V_{SDA}, V_{CLKIO}$	-0.3	—	$V_{DD} + 0.3$	V	*2
	V_{NRST}	-0.3	—	$V_{CC} + 0.3$	V	*2
Output Voltage Range	$V_{LDO}, V_{CLKIO}, V_{Z1}, V_{Z2}, V_{Z3}, V_{Z4}, V_{Z5}, V_{Z6}, V_{Z7}, V_{Z8}, V_{Z9}, V_{Z10}$	-0.3	—	$V_{CC} + 0.3$	V	*2

Note: *1 : The values under the condition not exceeding the above absolute maximum ratings and the power dissipation.

Do not apply external currents and voltages to any pin not specifically mentioned.

Voltage values, unless otherwise specified, are with respect to GND. GND is voltage for AGND, PGND1 and GND2.

V_{CC} is voltage for VCC1 and VCC2. V_{DD} is voltage for VDD.

*2 : ($V_{CC} + 0.3$) V must not exceed 6 V. ($V_{DD} + 0.3$) V must not exceed 6 V.

ELECTRICAL CHARACTERISTICS

$V_{CC} = 3.6\text{ V}$, $V_{DD} = 1.85\text{ V}$

Notes: $T_a = 25^\circ\text{C} \pm 2^\circ\text{C}$ unless otherwise noted.

Parameter	Symbol	Condition	Limits			Unit	Note
			Min	Typ	Max		
Circuit Current							
Circuit Current (1) OFF Mode	I_{CC1}	NRST = 0V	—	0	1	μA	—
Circuit Current (2) OFF Mode	I_{CC2}	NRST = 3.6V	—	250	500	μA	—
Internal Oscillator							
Oscillation Frequency	FDC1	$V_{CC} = 3.6\text{ V}$	1.92	2.40	2.88	MHz	—
SCAN Switch							
Switch On Resistance	RSCAN	$V_{CC} = 3.6\text{ V}$ $I_{Z1-Z9} = -20\text{ mA}$	—	1.5	3	Ω	—
Constant Voltage Source (LDO)							
Output voltage (1)	V_{L1}	$I_{LDO} = -10\ \mu\text{A}$	2.75	2.85	2.95	V	—
Output voltage (2)	V_{L2}	$I_{LDO} = -15\text{ mA}$	2.75	2.85	2.95	V	—
CLKIO							
High Level Input Voltage Range	V_{IH1}	High Level Acknowledged Voltage (At External CLK Input Mode)	$0.7 \times V_{DD}$	—	$V_{DD} + 0.3$	V	—
Low Level Input Voltage Range	V_{IL1}	Low Level Acknowledged Voltage (At External CLK Input Mode)	-0.3	—	$0.3 \times V_{DD}$	V	—
High Level Output Voltage	V_{OH1}	$I_{CLKIO} = -1\text{ mA}$ (At Internal CLK Output Mode)	$0.8 \times V_{DD}$	—	$V_{DD} + 0.3$	V	—
Low Level Output Voltage	V_{OL1}	$I_{CLKIO} = 1\text{ mA}$ (At Internal CLK Output Mode)	-0.3	—	$0.2 \times V_{DD}$	V	—
High Level input Current	I_{IH1}	$V_{CC} = 5.5\text{ V}$ $V_{CLKIO} = 5.5\text{ V}$	-1	0	1	μA	—
Low Level input Current	I_{IL1}	$V_{CC} = 5.5\text{ V}$ $V_{CLKIO} = 0\text{ V}$	-1	0	1	μA	—

ELECTRICAL CHARACTERISTICS (Continued)

$V_{CC} = 3.6\text{ V}$, $V_{DD} = 1.85\text{ V}$

Notes: $T_a = 25^\circ\text{C} \pm 2^\circ\text{C}$ unless otherwise noted.

Parameter	Symbol	Condition	Limits			Unit	Note
			Min	Typ	Max		
Constant Current Source (Matrix LED)							
Output Current (1)	I_{MX1}	LED Current Setting = 20 mA $I_{MAX} = [011]$, BRTXX = [1010] $V_{Z1-Z10} = 1\text{ V}$	19	20	21	mA	*1
DAC Current Step	DACSTEP	DAC Constant Current Mode LED Current Setting = 20 mA $I_{MAX} = [011]$, BRTXX = [1010] $V_{Z1-Z10} = 1\text{ V}$, IDAC1 = I_{Z1-Z10} LED Current Setting = 22 mA $I_{MAX} = [011]$, BRTXX = [1011] $V_{Z1-Z10} = 1\text{ V}$, IDAC2 = I_{Z1-Z10} DACSTEP = IDAC2 – IDAC1	0	2	4	mA	*2
OFF Mode Leak Current1	I_{MXOFF1}	$V_{CC} = 5.5\text{ V}$, $V_{DD} = 5.5\text{ V}$ MTXON = 0 $V_{Z1-Z10} = 5.5\text{ V}$	-1	—	1	μA	*3
OFF Mode Leak Current2	I_{MXOFF2}	$V_{CC} = 5.5\text{ V}$, $V_{DD} = 5.5\text{ V}$ MTXON = 0 $V_{Z1-Z10} = 0\text{ V}$	-1	—	1	μA	*3
Channel Difference	I_{MXCH}	LED Current Setting = 20 mA $I_{MAX} = [011]$, BRTXX = [1010] Difference of Z1 to 10 current from the average current value	-5	—	5	%	—
Voltage at which LED driver can keep constant current value							
LED Driver Voltage	V_{LD2}	LED Current Setting = 20 mA $I_{MAX} = [011]$, BRTXX = [1010] Voltage at which LED Current change within $\pm 5\%$ compared with LED Current of pin voltage = 0.5 V.	0.4	—	—	V	—

Note: * 1: This is allowable value when recommended parts (ERJ2RHD393X) are used for the terminal IREF.

* 2: Current step for individual channels (Z1~Z10).

* 3: Please refer to page 23 for more information on the setting.

ELECTRICAL CHARACTERISTICS (Continued)

$V_{CC} = 3.6\text{ V}$, $V_{DD} = 1.85\text{ V}$

Notes: $T_a = 25^\circ\text{C} \pm 2^\circ\text{C}$ unless otherwise noted.

Parameter	Symbol	Condition	Limits			Unit	Note
			Min	Typ	Max		
SLAVSEL							
High Level Input Voltage Range	V_{IH2}	High Level Acknowledged Voltage	$0.7 \times V_{DD}$	—	$V_{DD} + 0.3$	V	—
Low Level Input Voltage Range	V_{IL2}	Low Level Acknowledged Voltage	-0.3	—	$0.3 \times V_{DD}$	V	—
High Level Input Current	I_{IH2}	$V_{CC} = 5.5\text{ V}$ $V_{SLAVSEL} = 3.6\text{ V}$	-1	0	1	μA	—
Low Level Input Current	I_{IL2}	$V_{CC} = 5.5\text{ V}$ $V_{SLAVSEL} = 0\text{ V}$	-1	0	1	μA	—
NRST							
High Level Input Voltage Range	V_{IH3}	High Level Acknowledged Voltage	1.5	—	$V_{CC} + 0.3$	V	—
Low Level Input Voltage Range	V_{IL3}	Low Level Acknowledged Voltage	-0.3	—	0.6	V	—
High Level Input Current	I_{IH3}	$V_{CC} = 5.5\text{ V}$ $V_{NRST} = 3.6\text{ V}$	-1	0	1	μA	—
Low Level Input Current	I_{IL3}	$V_{CC} = 5.5\text{ V}$ $V_{NRST} = 0\text{ V}$	-1	0	1	μA	—
I²C bus (Internal I/O stage characteristics)							
Low-level input voltage	V_{IL}	Voltage which recognized that SDA and SCL are Low-level	-0.5	—	$0.3 \times V_{DD}$	V	*4
High-level input voltage	V_{IH}	Voltage which recognized that SDA and SCL are High-level	$0.7 \times V_{DD}$	—	$V_{DD}^{MAX} + 0.5$	V	*4
Low-level output voltage 1	V_{OL1}	$V_{DD} > 2\text{ V}$ $I_{SDA} = 3\text{ mA}$	0	—	0.4	V	—
Low-level output voltage 2	V_{OL2}	$V_{DD} < 2\text{ V}$ $I_{SDA} = 3\text{ mA}$	0	—	$0.2 \times V_{DD}$	V	—
Low-level output current	I_{OL}	$V_{SDA} = 0.4\text{ V}$	20	—	—	mA	—
Input current each I/O pin	I_i	$V_{CC} = 5.5\text{ V}$, $V_{DD} = 5.5\text{ V}$ V_{SCL} , $V_{SDA} = 0.1 V_{DD}^{MAX}$ to $0.9 V_{DD}^{MAX}$	-10	0	10	μA	—
SCL clock frequency	f_{SCL}	—	0	—	1 000	kHz	—

Note: V_{DD}^{MAX} refers to the maximum operating supply voltage of V_{DD} .

*4 : The input threshold voltage of I²C bus (V_{th}) is linked to V_{DD} (I²C bus I/O stage supply voltage).

In case the pull-up voltage is not V_{DD} , the threshold voltage (V_{th}) is fixed to $((V_{DD} / 2) \pm (\text{Schmitt width}) / 2)$ and High-level, Low-level of input voltage are not specified. In this case, pay attention to Low-level (max.) value (V_{ILMAX}).

It is recommended that the pull-up voltage of I²C bus is set to the I²C bus I/O stage supply voltage (V_{DD}).

ELECTRICAL CHARACTERISTICS (Continued)

$V_{CC} = 3.6\text{ V}$, $V_{DD} = 1.85\text{ V}$

Notes: $T_a = 25^\circ\text{C} \pm 2^\circ\text{C}$ unless otherwise noted.

Parameter	Symbol	Condition	Limits			Unit	Note
			Min	Typ	Max		
TSD (Thermal shutdown protection circuit)							
Detection temperature	Tdet	Temperature which Constant current circuit, and Matrix SW turn off.	—	150	—	°C	*5 *6
Constant Voltage Source (LDO)							
Ripple rejection ratio (1)	PSL11	$V_{CC} = 3.6\text{ V} + 0.3\text{ V[p-p]}$ $f = 1\text{ kHz}$ $I_{LDO} = -15\text{ mA}$ $PSL11 = 20\log(acV_{LDO} / 0.3)$	—	- 50	—	dB	*6
Ripple rejection ratio (2)	PSL12	$V_{CC} = 3.6\text{ V} + 0.3\text{ V[p-p]}$ $f = 10\text{ kHz}$ $I_{LDO} = -15\text{ mA}$ $PSL12 = 20\log(acV_{LDO} / 0.3)$	—	- 40	—	dB	*6
Short-circuit protection current	I_{PT1}	$V_{LDO} = 0\text{ V}$	—	40	—	mA	*6
I²C bus (Internal I/O stage characteristics) (Continued)							
Hysteresis of Schmitt trigger input 1	V_{hys1}	$V_{DD} > 2\text{ V}$, Hysteresis of SDA, SCL	$0.05 \times V_{DD}$	—	—	V	*7 *8
Hysteresis of Schmitt trigger input 2	V_{hys2}	$V_{DD} < 2\text{ V}$, Hysteresis of SDA, SCL	$0.1 \times V_{DD}$	—	—	V	*7 *8
Output fall time from V_{IHMIN} to V_{ILMAX}	t_{of}	Bus capacitance : 10pF to 550pF $I_P \leq 20\text{ mA}$ ($V_{OLMAX} = 0.4\text{ V}$) I_P : Max. sink current	—	—	120	ns	*7 *8
Pulse width of spikes which must be suppressed by the input filter	t_{SP}	—	0	—	50	ns	*7 *8
Capacitance for each I/O pin	C_i	—	—	—	10	pF	*7 *8

Note: *5 : Constant current circuit, and Matrix SW turn off and IC reset when TSD operates.

*6 : Typical Design Value

*7 : The timing of Fast-mode Plus devices in I²C-bus is specified in Page.10. All values referred to V_{IHMIN} and V_{ILMAX} level.

*8 : These are values checked by design but not production tested.

ELECTRICAL CHARACTERISTICS (Continued)

$V_{CC} = 3.6\text{ V}$, $V_{DD} = 1.85\text{ V}$

Notes: $T_a = 25^\circ\text{C} \pm 2^\circ\text{C}$ unless otherwise noted.

Parameter	Symbol	Condition	Limits			Unit	Note
			Min	Typ	Max		
I²C bus (Bus line specifications) (Continue)							
Hold time (repeated) START condition	$t_{HD:STA}$	The first clock pulse is generated after $t_{HD:STA}$.	0.26	—	—	μs	*7 *8
Low period of the SCL clock	t_{LOW}	—	0.5	—	—	μs	*7 *8
High period of the SCL clock	t_{HIGH}	—	0.26	—	—	μs	*7 *8
Set-up time for a repeat START condition	$t_{SU:STA}$	—	0.26	—	—	μs	*7 *8
Data hold time	$t_{HD:DAT}$	—	0	—	—	μs	*7 *8
Data set-up time	$t_{SU:DAT}$	—	50	—	—	ns	*7 *8
Rise time of both SDA and SCL signals	t_r	—	—	—	120	ns	*7 *8
Fall time of both SDA and SCL signals	t_f	—	—	—	120	ns	*7 *8
Set-up time of STOP condition	$t_{SU:STO}$	—	0.26	—	—	μs	*7 *8
Bus free time between STOP and START condition	t_{BUF}	—	0.5	—	—	μs	*7 *8
Capacitive load for each bus line	C_b	—	—	—	550	pF	*7 *8
Data valid time	$t_{VD:DAT}$	—	—	—	0.45	μs	*7 *8
Data valid acknowledge	$t_{VD:ACK}$	—	—	—	0.45	μs	*7 *8
Noise margin at the Low-level for each connected device	V_{nL}	—	$0.1 \times V_{DD}$	—	—	V	*7 *8
Noise margin at the High-level for each connected device	V_{nH}	—	$0.2 \times V_{DD}$	—	—	V	*7 *8

Note: *7 : The timing of Fast-mode Plus devices in I²C-bus is specified in Page 10. All values referred to V_{IHMIN} and V_{ILMAX} level.

*8 : These are values checked by design but not production tested.

ELECTRICAL CHARACTERISTICS (Continued)

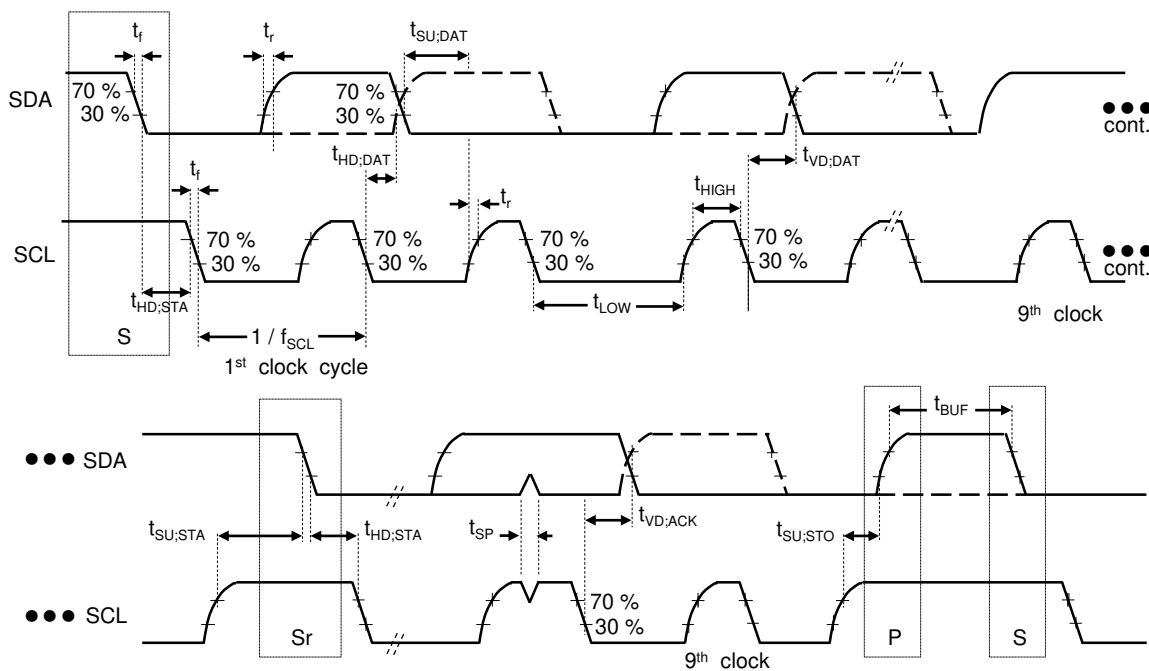

$V_{ILMAX} = 0.3 V_{DD}$
 $V_{IHMIN} = 0.7 V_{DD}$

- S : START condition
- Sr : Repetitive START condition
- P : STOP condition

PIN CONFIGURATION

TOP VIEW

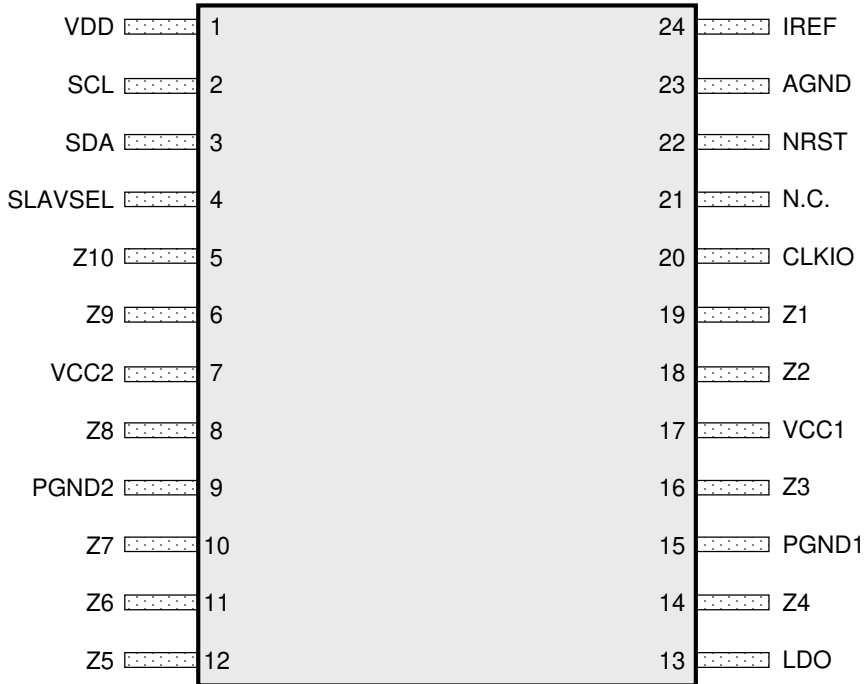

PIN FUNCTIONS

Pin No.	Pin name	Type	Description	Pin processing at unused
1	VDD	Power supply	Power supply for I ² C interface	(Required pin)
2	SCL	Input	Clock input pin for I ² C interface	(Required pin)
3	SDA	Input/Output	Data input / output pin for I ² C interface	(Required pin)
4	SLAVSEL	Input	Slave address selection pin for I ² C interface	GND or VCC or SCL or SDA
5	Z10	Output	Constant current circuit, PWM control output pin, Control switch pin for matrix driver	Open
6	Z9	Output	Constant current circuit, PWM control output pin, Control switch pin for matrix driver	Open
7 17	VCC2 VCC1	Power supply	Power supply for matrix driver, Internal reference circuit	Battery or External power supply
8	Z8	Output	Constant current circuit, PWM control output pin, Control switch pin for matrix driver	Open
9 15	PGND2 PGND1	Ground	Power Ground pin	(Required pin)
10	Z7	Output	Constant current circuit, PWM control output pin, Control switch pin for matrix driver	Open
11	Z6	Output	Constant current circuit, PWM control output pin, Control switch pin for matrix driver	Open
12	Z5	Output	Constant current circuit, PWM control output pin, Control switch pin for matrix driver	Open
13	LDO	Output	LDO output pin	(Required pin)
14	Z4	Output	Constant current circuit, PWM control output pin, Control switch pin for matrix driver	Open
16	Z3	Output	Constant current circuit, PWM control output pin, Control switch pin for matrix driver	Open
18	Z2	Output	Constant current circuit, PWM control output pin, Control switch pin for matrix driver	Open
19	Z1	Output	Constant current circuit, PWM control output pin, Control switch pin for matrix driver	Open
20	CLKIO	Input/Output	Reference clock input output / Music Input pin	Open
21	—	—	N.C	—
22	NRST	Input	Reset input pin	(Required pin)
23	AGND	Ground	Ground pin	(Required pin)
24	IREF	Output	Resistor connection pin for constant current setup	(Required pin)

FUNCTIONAL BLOCK DIAGRAM

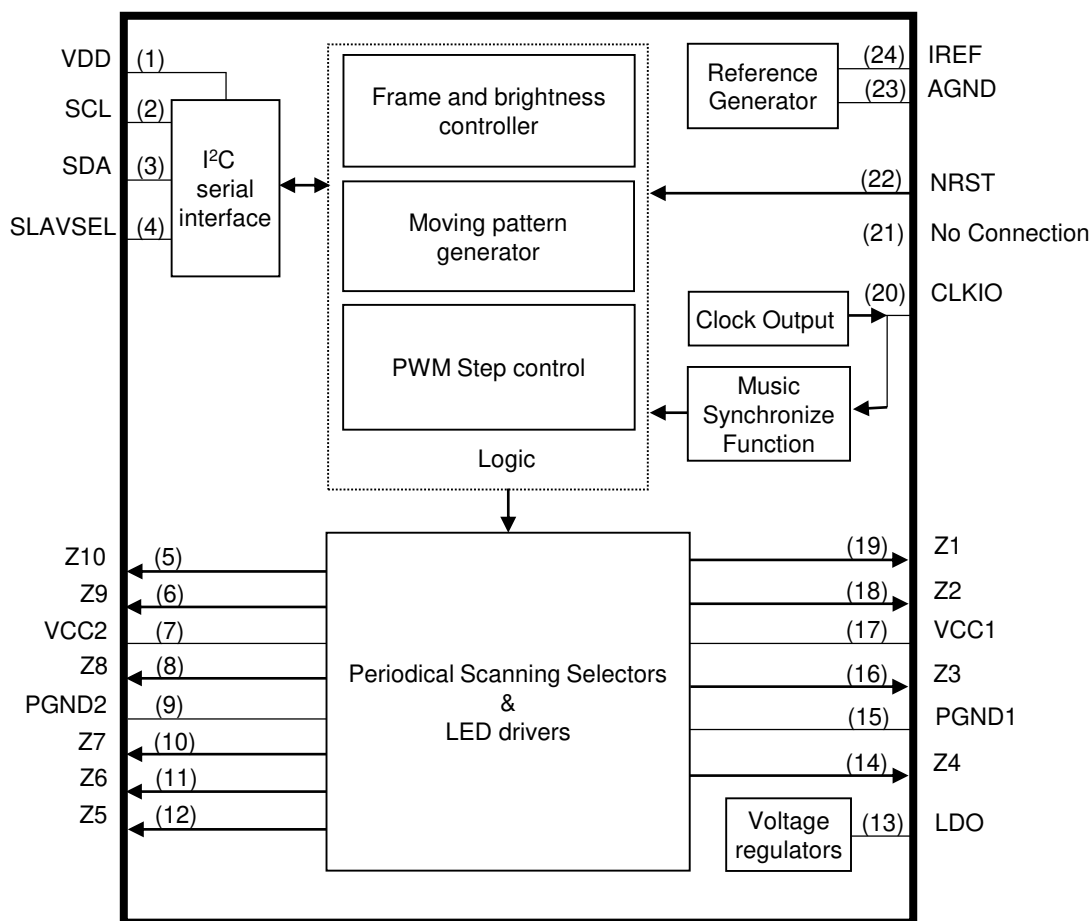

Notes: This block diagram is for explaining functions. Part of the block diagram may be omitted, or it may be simplified.

OPERATION

1. Power Supply Sequence

1.1 Power ON

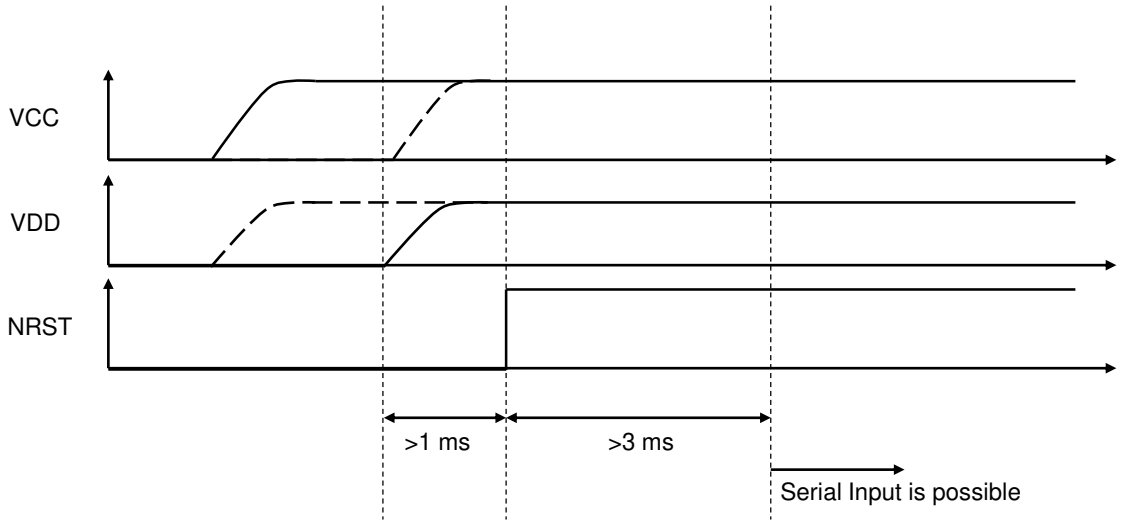

Note: For the Startup Timing of VCC and VDD, it is possible to be changed.

1.2 Power OFF

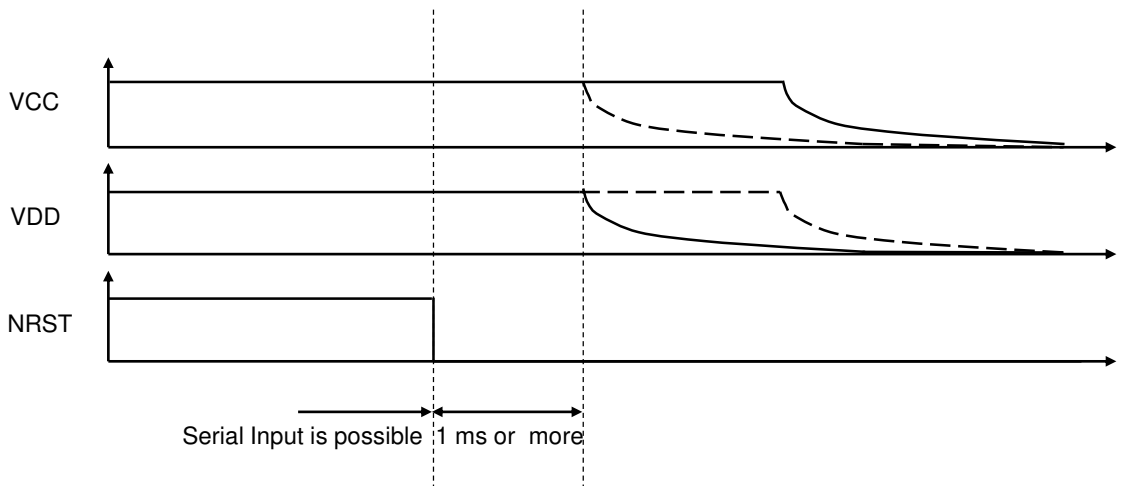

Note: For the Shut down Timing of VCC and VDD, it is possible to be changed.

OPERATION (Continued)

2. Register Map

ADDR	Register Name	Default	R/W	DATA							
				D7	D6	D5	D4	D3	D2	D1	D0
01h	RST	00h	W	--	--	--	--	--	--	RAMRST	SRST
02h	POWERCNT	00h	R/W		--	--	--	--	--	--	OSCEN
03h	reserved	--	--	--	--	--	--	--	--	--	--
04h	OPTION	00h	R/W	--	--	--	--	ZPDEN	MLDACT	CLKOUT	EXTCLK
05h	MTXON	1Eh	R/W	--	--	--	IMAX Reserved	IMAX[2:0]			MTXON
06h	PWMEN1	00h	R/W	PWMA8	PWMA7	PWMA6	PWMA5	PWMA4	PWMA3	PWMA2	PWMA1
07h	PWMEN2	00h	R/W	PWMB7	PWMB6	PWMB5	PWMB4	PWMB3	PWMB2	PWMB1	PWMA9
08h	PWMEN3	00h	R/W	PWMC6	PWMC5	PWMC4	PWMC3	PWMC2	PWMC1	PWMB9	PWMB8
09h	PWMEN4	00h	R/W	PWMD5	PWMD4	PWMD3	PWMD2	PWMD1	PWMC9	PWMC8	PWMC7
0Ah	PWMEN5	00h	R/W	PWME4	PWME3	PWME2	PWME1	PWMD9	PWMD8	PWMD7	PWMD6
0Bh	PWMEN6	00h	R/W	PWMF3	PWMF2	PWMF1	PWME9	PWME8	PWME7	PWME6	PWME5
0Ch	PWMEN7	00h	R/W	PWVG2	PWVG1	PWMF9	PWMF8	PWMF7	PWMF6	PWMF5	PWMF4
0Dh	PWMEN8	00h	R/W	PWMH1	PWVG9	PWVG8	PWVG7	PWVG6	PWVG5	PWVG4	PWVG3
0Eh	PWMEN9	00h	R/W	PWMH9	PWMH8	PWMH7	PWMH6	PWMH5	PWMH4	PWMH3	PWMH2
0Fh	PWMEN10	00h	R/W	PWMI8	PWMI7	PWMI6	PWMI5	PWMI4	PWMI3	PWMI2	PWMI1
10h	PWMEN11	00h	R/W	--	--	--	--	--	--	--	PWMI9
11h	MLDEN1	00h	R/W	MLDA8	MLDA7	MLDA6	MLDA5	MLDA4	MLDA3	MLDA2	MLDA1
12h	MLDEN2	00h	R/W	MLDB7	MLDB6	MLDB5	MLDB4	MLDB3	MLDB2	MLDB1	MLDA9
13h	MLDEN3	00h	R/W	MLDC6	MLDC5	MLDC4	MLDC3	MLDC2	MLDC1	MLDB9	MLDB8
14h	MLDEN4	00h	R/W	MLDD5	MLDD4	MLDD3	MLDD2	MLDD1	MLDC9	MLDC8	MLDC7
15h	MLDEN5	00h	R/W	MLDE4	MLDE3	MLDE2	MLDE1	MLDD9	MLDD8	MLDD7	MLDD6
16h	MLDEN6	00h	R/W	MLDF3	MLDF2	MLDF1	MLDE9	MLDE8	MLDE7	MLDE6	MLDE5
17h	MLDEN7	00h	R/W	MLDG2	MLDG1	MLDF9	MLDF8	MLDF7	MLDF6	MLDF5	MLDF4
18h	MLDEN8	00h	R/W	MLDH1	MLDG9	MLDG8	MLDG7	MLDG6	MLDG5	MLDG4	MLDG3
19h	MLDEN9	00h	R/W	MLDH9	MLDH8	MLDH7	MLDH6	MLDH5	MLDH4	MLDH3	MLDH2
1Ah	MLDEN10	00h	R/W	MLDI8	MLDI7	MLDI6	MLDI5	MLDI4	MLDI3	MLDI2	MLDI1
1Bh	MLDEN11	00h	R/W	--	--	--	--	--	--	--	MLDI9
2Ah	MLDMODE1	00h	R/W	--	--	--	--	GRP9_9	GRP9_8	GRP9_2	GRP9_1
2Bh	THOLD	00h	R/W	THOLD[7:0]							

Note: "Reserved" registers and data bits indicated by "--" cannot be accessed. "Reserved" registers are not used.

For data bits indicated by "--" in other registers except from "reversed" registers, will return "zero" value if these bits are read.

Writing to these bits will be ignored. IMAX Reserved will give default value [1].

OPERATION (Continued)

2. Register Map (Continued)

ADDR	Register Name	Default	R/W	DATA							
				D7	D6	D5	D4	D3	D2	D1	D0
2Ch	CONSTX6_1	00h	R/W	--	--	X6	X5	X4	X3	X2	X1
2Dh	CONSTX10_7	00h	R/W	--	--	--	--	X10	X9	X8	X7
2Eh	CONSTY6_1	00h	R/W	--	--	Y6	Y5	Y4	Y3	Y2	Y1
2Fh	CONSTY9_7	00h	R/W	--	--	--	--	--	Y9	Y8	Y7
30h	MASKY6_1	00h	R/W	--	--	Y6MSK	Y5MSK	Y4MSK	Y3MSK	Y2MSK	Y1MSK
31h	MASKY9_7	00h	R/W	--	--	--	--	--	Y9MSK	Y8MSK	Y7MSK
32h	SLPTIME	00h	R/W	--	--	--	FADTIM	SLOPEEXTL[1:0]		SLOPEEXTH[1:0]	
33h	MLDCOM	03h	R/W	--	--	--	--	--	MLDCOM[2:0]		
34h	reserved	--	--	--	--	--	--	--	--	--	--
35h	reserved	--	--	--	--	--	--	--	--	--	--
36h	SCANSET	08h	R/W	--	--	--	--	SCANSET[3:0]			
40h	DTA1	00h	R/W	DTA1[7:0]							
41h	DTA2	00h	R/W	DTA2[7:0]							
42h	DTA3	00h	R/W	DTA3[7:0]							
43h	DTA4	00h	R/W	DTA4[7:0]							
44h	DTA5	00h	R/W	DTA5[7:0]							
45h	DTA6	00h	R/W	DTA6[7:0]							
46h	DTA7	00h	R/W	DTA7[7:0]							
47h	DTA8	00h	R/W	DTA8[7:0]							
48h	DTA9	00h	R/W	DTA9[7:0]							
49h	DTB1	00h	R/W	DTB1[7:0]							
4Ah	DTB2	00h	R/W	DTB2[7:0]							
4Bh	DTB3	00h	R/W	DTB3[7:0]							
4Ch	DTB4	00h	R/W	DTB4[7:0]							
4Dh	DTB5	00h	R/W	DTB5[7:0]							
4Eh	DTB6	00h	R/W	DTB6[7:0]							
4Fh	DTB7	00h	R/W	DTB7[7:0]							
50h	DTB8	00h	R/W	DTB8[7:0]							
51h	DTB9	00h	R/W	DTB9[7:0]							

Note: "Reserved" registers and data bits indicated by "--" cannot be accessed. "Reserved" registers are not used.

For data bits indicated by "--" in other registers except from "Reserved" registers, will return "zero" value if these bits are read.

Writing to these bits will be ignored.

OPERATION (Continued)

2. Register Map (Continued)

ADDR	Register Name	Default	R/W	DATA							
				D7	D6	D5	D4	D3	D2	D1	D0
52h	DTC1	00h	R/W	DTC1[7:0]							
53h	DTC2	00h	R/W	DTC2[7:0]							
54h	DTC3	00h	R/W	DTC3[7:0]							
55h	DTC4	00h	R/W	DTC4[7:0]							
56h	DTC5	00h	R/W	DTC5[7:0]							
57h	DTC6	00h	R/W	DTC6[7:0]							
58h	DTC7	00h	R/W	DTC7[7:0]							
59h	DTC8	00h	R/W	DTC8[7:0]							
5Ah	DTC9	00h	R/W	DTC9[7:0]							
5Bh	DTD1	00h	R/W	DTD1[7:0]							
5Ch	DTD2	00h	R/W	DTD2[7:0]							
5Dh	DTD3	00h	R/W	DTD3[7:0]							
5Eh	DTD4	00h	R/W	DTD4[7:0]							
5Fh	DTD5	00h	R/W	DTD5[7:0]							
60h	DTD6	00h	R/W	DTD6[7:0]							
61h	DTD7	00h	R/W	DTD7[7:0]							
62h	DTD8	00h	R/W	DTD8[7:0]							
63h	DTD9	00h	R/W	DTD9[7:0]							
64h	DTE1	00h	R/W	DTE1[7:0]							
65h	DTE2	00h	R/W	DTE2[7:0]							
66h	DTE3	00h	R/W	DTE3[7:0]							
67h	DTE4	00h	R/W	DTE4[7:0]							
68h	DTE5	00h	R/W	DTE5[7:0]							
69h	DTE6	00h	R/W	DTE6[7:0]							
6Ah	DTE7	00h	R/W	DTE7[7:0]							
6Bh	DTE8	00h	R/W	DTE8[7:0]							
6Ch	DTE9	00h	R/W	DTE9[7:0]							
6Dh	DTF1	00h	R/W	DTF1[7:0]							
6Eh	DTF2	00h	R/W	DTF2[7:0]							

OPERATION (Continued)

2. Register Map (Continued)

ADDR	Register Name	Default	R/W	DATA							
				D7	D6	D5	D4	D3	D2	D1	D0
6Fh	DTF3	00h	R/W	DTF3[7:0]							
70h	DTF4	00h	R/W	DTF4[7:0]							
71h	DTF5	00h	R/W	DTF5[7:0]							
72h	DTF6	00h	R/W	DTF6[7:0]							
73h	DTF7	00h	R/W	DTF7[7:0]							
74h	DTF8	00h	R/W	DTF8[7:0]							
75h	DTF9	00h	R/W	DTF9[7:0]							
76h	DTG1	00h	R/W	DTG1[7:0]							
77h	DTG2	00h	R/W	DTG2[7:0]							
78h	DTG3	00h	R/W	DTG3[7:0]							
79h	DTG4	00h	R/W	DTG4[7:0]							
7Ah	DTG5	00h	R/W	DTG5[7:0]							
7Bh	DTG6	00h	R/W	DTG6[7:0]							
7Ch	DTG7	00h	R/W	DTG7[7:0]							
7Dh	DTG8	00h	R/W	DTG8[7:0]							
7Eh	DTG9	00h	R/W	DTG9[7:0]							
7Fh	DTH1	00h	R/W	DTH1[7:0]							
80h	DTH2	00h	R/W	DTH2[7:0]							
81h	DTH3	00h	R/W	DTH3[7:0]							
82h	DTH4	00h	R/W	DTH4[7:0]							
83h	DTH5	00h	R/W	DTH5[7:0]							
84h	DTH6	00h	R/W	DTH6[7:0]							
85h	DTH7	00h	R/W	DTH7[7:0]							
86h	DTH8	00h	R/W	DTH8[7:0]							
87h	DTH9	00h	R/W	DTH9[7:0]							
88h	DTI1	00h	R/W	DTI1[7:0]							
89h	DTI2	00h	R/W	DTI2[7:0]							
8Ah	DTI3	00h	R/W	DTI3[7:0]							
8Bh	DTI4	00h	R/W	DTI4[7:0]							

OPERATION (Continued)

2. Register Map (Continued)

ADDR	Register Name	Default	R/W	DATA							
				D7	D6	D5	D4	D3	D2	D1	D0
8Ch	DTI5	00h	R/W	DTI5[7:0]							
8Dh	DTI6	00h	R/W	DTI6[7:0]							
8Eh	DTI7	00h	R/W	DTI7[7:0]							
8Fh	DTI8	00h	R/W	DTI8[7:0]							
90h	DTI9	00h	R/W	DTI9[7:0]							
91h	A1	00h	R/W	BRTA1[3:0]			--	SDTA1[2:0]			
92h	A2	00h	R/W	BRTA2[3:0]			--	SDTA2[2:0]			
93h	A3	00h	R/W	BRTA3[3:0]			--	SDTA3[2:0]			
94h	A4	00h	R/W	BRTA4[3:0]			--	SDTA4[2:0]			
95h	A5	00h	R/W	BRTA5[3:0]			--	SDTA5[2:0]			
96h	A6	00h	R/W	BRTA6[3:0]			--	SDTA6[2:0]			
97h	A7	00h	R/W	BRTA7[3:0]			--	SDTA7[2:0]			
98h	A8	00h	R/W	BRTA8[3:0]			--	SDTA8[2:0]			
99h	A9	00h	R/W	BRTA9[3:0]			--	SDTA9[2:0]			
9Ah	B1	00h	R/W	BRTB1[3:0]			--	SDTB1[2:0]			
9Bh	B2	00h	R/W	BRTB2[3:0]			--	SDTB2[2:0]			
9Ch	B3	00h	R/W	BRTB3[3:0]			--	SDTB3[2:0]			
9Dh	B4	00h	R/W	BRTB4[3:0]			--	SDTB4[2:0]			
9Eh	B5	00h	R/W	BRTB5[3:0]			--	SDTB5[2:0]			
9Fh	B6	00h	R/W	BRTB6[3:0]			--	SDTB6[2:0]			
A0h	B7	00h	R/W	BRTB7[3:0]			--	SDTB7[2:0]			
A1h	B8	00h	R/W	BRTB8[3:0]			--	SDTB8[2:0]			
A2h	B9	00h	R/W	BRTB9[3:0]			--	SDTB9[2:0]			
A3h	C1	00h	R/W	BRTC1[3:0]			--	SDTC1[2:0]			
A4h	C2	00h	R/W	BRTC2[3:0]			--	SDTC2[2:0]			
A5h	C3	00h	R/W	BRTC3[3:0]			--	SDTC3[2:0]			
A6h	C4	00h	R/W	BRTC4[3:0]			--	SDTC4[2:0]			
A7h	C5	00h	R/W	BRTC5[3:0]			--	SDTC5[2:0]			
A8h	C6	00h	R/W	BRTC6[3:0]			--	SDTC6[2:0]			

Note: Data bits indicated by "--" cannot be accessed. It will return "zero" value if these bits are read.
Writing to these bits will be ignored.

OPERATION (Continued)

2. Register Map (Continued)

ADDR	Register Name	Default	R/W	DATA							
				D7	D6	D5	D4	D3	D2	D1	D0
A9h	C7	00h	R/W	BRTC7[3:0]				--	SDTC7[2:0]		
AAh	C8	00h	R/W	BRTC8[3:0]				--	SDTC8[2:0]		
ABh	C9	00h	R/W	BRTC9[3:0]				--	SDTC9[2:0]		
ACh	D1	00h	R/W	BRTD1[3:0]				--	SDTD1[2:0]		
ADh	D2	00h	R/W	BRTD2[3:0]				--	SDTD2[2:0]		
A Eh	D3	00h	R/W	BRTD3[3:0]				--	SDTD3[2:0]		
AFh	D4	00h	R/W	BRTD4[3:0]				--	SDTD4[2:0]		
B0h	D5	00h	R/W	BRTD5[3:0]				--	SDTD5[2:0]		
B1h	D6	00h	R/W	BRTD6[3:0]				--	SDTD6[2:0]		
B2h	D7	00h	R/W	BRTD7[3:0]				--	SDTD7[2:0]		
B3h	D8	00h	R/W	BRTD8[3:0]				--	SDTD8[2:0]		
B4h	D9	00h	R/W	BRTD9[3:0]				--	SDTD9[2:0]		
B5h	E1	00h	R/W	BRTE1[3:0]				--	SDTE1[2:0]		
B6h	E2	00h	R/W	BRTE2[3:0]				--	SDTE2[2:0]		
B7h	E3	00h	R/W	BRTE3[3:0]				--	SDTE3[2:0]		
B8h	E4	00h	R/W	BRTE4[3:0]				--	SDTE4[2:0]		
B9h	E5	00h	R/W	BRTE5[3:0]				--	SDTE5[2:0]		
BAh	E6	00h	R/W	BRTE6[3:0]				--	SDTE6[2:0]		
BBh	E7	00h	R/W	BRTE7[3:0]				--	SDTE7[2:0]		
BCh	E8	00h	R/W	BRTE8[3:0]				--	SDTE8[2:0]		
BDh	E9	00h	R/W	BRTE9[3:0]				--	SDTE9[2:0]		
BEh	F1	00h	R/W	BRTF1[3:0]				--	SDTF1[2:0]		
BFh	F2	00h	R/W	BRTF2[3:0]				--	SDTF2[2:0]		
C0h	F3	00h	R/W	BRTF3[3:0]				--	SDTF3[2:0]		
C1h	F4	00h	R/W	BRTF4[3:0]				--	SDTF4[2:0]		
C2h	F5	00h	R/W	BRTF5[3:0]				--	SDTF5[2:0]		
C3h	F6	00h	R/W	BRTF6[3:0]				--	SDTF6[2:0]		
C4h	F7	00h	R/W	BRTF7[3:0]				--	SDTF7[2:0]		
C5h	F8	00h	R/W	BRTF8[3:0]				--	SDTF8[2:0]		

Note: Data bits indicated by "--" cannot be accessed. It will return "zero" value if these bits are read.
Writing to these bits will be ignored.

OPERATION (Continued)

2. Register Map (Continued)

ADDR	Register Name	Default	R/W	DATA							
				D7	D6	D5	D4	D3	D2	D1	D0
C6h	F9	00h	R/W	BRTF9[3:0]				--	SDTF9[2:0]		
C7h	G1	00h	R/W	BRTG1[3:0]				--	SDTG1[2:0]		
C8h	G2	00h	R/W	BRTG2[3:0]				--	SDTG2[2:0]		
C9h	G3	00h	R/W	BRTG3[3:0]				--	SDTG3[2:0]		
CAh	G4	00h	R/W	BRTG4[3:0]				--	SDTG4[2:0]		
CBh	G5	00h	R/W	BRTG5[3:0]				--	SDTG5[2:0]		
CCh	G6	00h	R/W	BRTG6[3:0]				--	SDTG6[2:0]		
CDh	G7	00h	R/W	BRTG7[3:0]				--	SDTG7[2:0]		
CEh	G8	00h	R/W	BRTG8[3:0]				--	SDTG8[2:0]		
CFh	G9	00h	R/W	BRTG9[3:0]				--	SDTG9[2:0]		
D0h	H1	00h	R/W	BRTH1[3:0]				--	SDTH1[2:0]		
D1h	H2	00h	R/W	BRTH2[3:0]				--	SDTH2[2:0]		
D2h	H3	00h	R/W	BRTH3[3:0]				--	SDTH3[2:0]		
D3h	H4	00h	R/W	BRTH4[3:0]				--	SDTH4[2:0]		
D4h	H5	00h	R/W	BRTH5[3:0]				--	SDTH5[2:0]		
D5h	H6	00h	R/W	BRTH6[3:0]				--	SDTH6[2:0]		
D6h	H7	00h	R/W	BRTH7[3:0]				--	SDTH7[2:0]		
D7h	H8	00h	R/W	BRTH8[3:0]				--	SDTH8[2:0]		
D8h	H9	00h	R/W	BRTH9[3:0]				--	SDTH9[2:0]		
D9h	I1	00h	R/W	BRTI1[3:0]				--	SDTI1[2:0]		
DAh	I2	00h	R/W	BRTI2[3:0]				--	SDTI2[2:0]		
DBh	I3	00h	R/W	BRTI3[3:0]				--	SDTI3[2:0]		
DCh	I4	00h	R/W	BRTI4[3:0]				--	SDTI4[2:0]		
DDh	I5	00h	R/W	BRTI5[3:0]				--	SDTI5[2:0]		
DEh	I6	00h	R/W	BRTI6[3:0]				--	SDTI6[2:0]		
DFh	I7	00h	R/W	BRTI7[3:0]				--	SDTI7[2:0]		
E0h	I8	00h	R/W	BRTI8[3:0]				--	SDTI8[2:0]		
E1h	I9	00h	R/W	BRTI9[3:0]				--	SDTI9[2:0]		

Note: Data bits indicated by "--" cannot be accessed. It will return "zero" value if these bits are read.
Writing to these bits will be ignored.

OPERATION (Continued)

3. Register map Detailed Explanation

Register Name		RST							
Address	R/W	D7	D6	D5	D4	D3	D2	D1	D0
01h	W	--	--	--	--	--	--	RAMRST	SRST
Default	00h	0	0	0	0	0	0	0	0

D1 : RAMRST RAM reset
 [0] : RAM can be overwrite (default)
 [1] : Clear all PWM duty setting and intensity setting

D0 : SRST Soft reset control
 [0] : Reset release state (default)
 [1] : Reset reset

- This register will auto-return to zero when written with "High" logic value.

Register Name		POWERCNT							
Address	R/W	D7	D6	D5	D4	D3	D2	D1	D0
02h	R/W	--	--	--	--	--	--	--	OSCEN
Default	00h	0	0	0	0	0	0	0	0

D0 : OSCEN Internal oscillator ON/OFF bit
 [0] : Internal oscillator OFF (default)
 [1] : Internal oscillator ON

- Oscillator will auto turn ON if any of the LED drivers are enabled (MTXON = 1) even if this bit is Low.

OPERATION (Continued)

3. Register map Detailed Explanation (Continued)

Register Name		OPTION							
Address	R/W	D7	D6	D5	D4	D3	D2	D1	D0
04h	R/W	--	--	--	--	ZPDEN	MLDACT	CLKOUT	EXTCLK
Default	00h	0	0	0	0	0	0	0	0

D3 : ZPDEN Ghost Image Prevention Enable
 [0] : Turn off ghost image prevention (default)
 [1] : Turn on ghost image prevention

D2 : MLDACT External Melody Input Selection
 [0] : Turn off melody mode (default)
 [1] : Turn on melody mode

D1 : CLKOUT Internal clock output enable
 [0] : Internal clock is not output from CLKOUT (default)
 [1] : Internal clock is output from CLKOUT

D0 : EXTCLK Internal/external synchronous clock selection
 [0] : Internal clock operation (default)
 [1] : External clock operation

- Ghost Image Prevention may not remove the ghost image perfectly. It depends on the LED color combination and LED connection method. Please refer to page 53 for details.
Please refer to page 54 for details especially when this IC is used for RGB driver.
- For D2, D1 and D0 cannot be set to High at the same time. In such case, the priority of operation will be EXTCLK then CLKOUT and then Melody Mode will have the least priority.

Register Name		MTXON							
Address	R/W	D7	D6	D5	D4	D3	D2	D1	D0
05h	R/W	--	--	--	IMAX Reserved	IMAX[2:0]			MTXON
Default	1Eh	0	0	0	1	1	1	1	0

D3-1: IMAX Maximum current setup selection
 [000] : 7.5 mA [100] : 37.5 mA
 [001] : 15 mA [101] : 45 mA
 [010] : 22.5 mA [110] : 52.5 mA
 [011] : 30 mA [111] : 60 mA (default)

D0 : MTXON LED Matrix Set up ON/OFF control
 [0] : OFF (default)
 [1] : ON

OPERATION (Continued)

3. Register map Detailed Explanation (Continued)

Register Name		PWMEN1							
Address	R/W	D7	D6	D5	D4	D3	D2	D1	D0
06h	R/W	PWMA8	PWMA7	PWMA6	PWMA5	PWMA4	PWMA3	PWMA2	PWMA1
Default	00h	0	0	0	0	0	0	0	0

D7 : PWMA8 A8 PWM mode enable
 [0] : Not PWM mode (default)
 [1] : PWM mode

D6 : PWMA7 A7 PWM mode enable
 [0] : Not PWM mode (default)
 [1] : PWM mode

D5 : PWMA6 A6 PWM mode enable
 [0] : Not PWM mode (default)
 [1] : PWM mode

D4 : PWMA5 A5 PWM mode enable
 [0] : Not PWM mode (default)
 [1] : PWM mode

D3 : PWMA4 A4 PWM mode enable
 [0] : Not PWM mode (default)
 [1] : PWM mode

D2 : PWMA3 A3 PWM mode enable
 [0] : Not PWM mode (default)
 [1] : PWM mode

D1 : PWMA2 A2 PWM mode enable
 [0] : Not PWM mode (default)
 [1] : PWM mode

D0 : PWMA1 A1 PWM mode enable
 [0] : Not PWM mode (default)
 [1] : PWM mode

- Please refer to Page.43 for LED's number A1 to A9.
- The definition for register addresses #07h to #10h is the same as address #06h.

OPERATION (Continued)

3. Register map Detailed Explanation (Continued)

Register Name		MLDEN1							
Address	R/W	D7	D6	D5	D4	D3	D2	D1	D0
11h	R/W	MLDA8	MLDA7	MLDA6	MLDA5	MLDA4	MLDA3	MLDA2	MLDA1
Default	00h	0	0	0	0	0	0	0	0

D7 : MLDA8 A8 Melody mode enable
[0] : Not Melody mode (default)
[1] : Melody mode

D6 : MLDA7 A7 Melody mode enable
[0] : Not Melody mode (default)
[1] : Melody mode

D5 : MLDA6 A6 Melody mode enable
[0] : Not Melody mode (default)
[1] : Melody mode

D4 : MLDA5 A5 Melody mode enable
[0] : Not Melody mode (default)
[1] : Melody mode

D3 : MLDA4 A4 Melody mode enable
[0] : Not Melody mode (default)
[1] : Melody mode

D2 : MLDA3 A3 Melody mode enable
[0] : Not Melody mode (default)
[1] : Melody mode

D1 : MLDA2 A2 Melody mode enable
[0] : Not PWM mode (default)
[1] : Melody mode

D0 : MLDA1 A1 Melody mode enable
[0] : Not Melody mode (default)
[1] : Melody mode

- Please refer to Page.43 for LED's number A1 to A9.
- The definition for register addresses #12h to #1Bh is the same as address #11h.

OPERATION (Continued)

3. Register map Detailed Explanation (Continued)

Register Name		MLDMODE1							
Address	R/W	D7	D6	D5	D4	D3	D2	D1	D0
2Ah	R/W	--	--	--	--	GRP9_9	GRP9_8	GRP9_2	GRP9_1
Default	00h	0	0	0	0	0	0	0	0

D3 : GRP9_9 Column 9 blink with external input as a group
 [0] : Normal (default)
 [1] : Melody mode (I9 → H9 → G9 → F9 → E9 → D9 → C9 → B9 → A9)

D2 : GRP9_8 Column 8 blink with external input as a group
 [0] : Normal (default)
 [1] : Melody mode (I8 → H8 → G8 → F8 → E8 → D8 → C8 → B8 → A8)

D1 : GRP9_2 Column 2 blink with external input as a group
 [0] : Normal (default)
 [1] : Melody mode (I2 → H2 → G2 → F2 → E2 → D2 → C2 → B2 → A2)

D0 : GRP9_1 Column 1 blink with external input as a group
 [0] : Normal (default)
 [1] : Melody mode (I1 → H1 → G1 → F1 → E1 → D1 → C1 → B1 → A1)

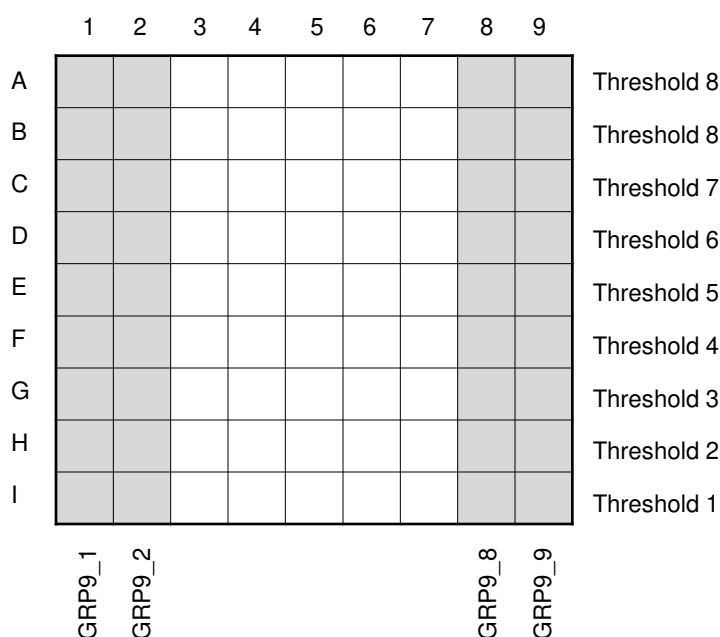

- During Bar Meter Mode, auto threshold detection should be used. This IC does not support Bar Meter Mode with fixed threshold setting.

OPERATION (Continued)

3. Register map Detailed Explanation (Continued)

Register Name		THOLD							
Address	R/W	D7	D6	D5	D4	D3	D2	D1	D0
2Bh	R/W	THOLD[7:0]							
Default	00h	0	0	0	0	0	0	0	0

D7 : THOLD[7] Threshold 8 is used as voltage detection.
 [0] : Others (default)
 [1] : Threshold 8 is used. (Threshold 8 is about 1.93 V)

D6 : THOLD[6] Threshold 7 is used as voltage detection.
 [0] : Others (default)
 [1] : Threshold 7 is used. (Threshold 7 is about 1.80 V)

D5 : THOLD[5] Threshold 6 is used as voltage detection.
 [0] : Others (default)
 [1] : Threshold 6 is used. (Threshold 6 is about 1.67 V)

D4 : THOLD[4] Threshold 5 is used as voltage detection.
 [0] : Others (default)
 [1] : Threshold 5 is used. (Threshold 5 is about 1.55 V)

D3 : THOLD[3] Threshold 4 is used as voltage detection.
 [0] : Others (default)
 [1] : Threshold 4 is used. (Threshold 4 is about 1.42 V)

D2 : THOLD[2] Threshold 3 is used as voltage detection.
 [0] : Others (default)
 [1] : Threshold 3 is used. (Threshold 3 is about 1.30 V)

D1 : THOLD[1] Threshold 2 is used as voltage detection.
 [0] : Others (default)
 [1] : Threshold 2 is used. (Threshold 2 is about 1.17 V)

D0 : THOLD[0] Threshold 1 is used as voltage detection.
 [0] : Others (default)
 [1] : Threshold 1 is used. (Threshold 1 is about 1.04 V)

- When all bits are set zero, threshold is in auto-detection mode (default)
- Do not set more than 1 register bit to logic "High" value at the same time.
- If 2 bits are set to "High" at the same time, system will only recognize the first "High" bit threshold that is set.

OPERATION (Continued)

3. Register map Detailed Explanation (Continued)

Register Name		CONSTX6_1							
Address	R/W	D7	D6	D5	D4	D3	D2	D1	D0
2Ch	R/W	--	--	X6	X5	X4	X3	X2	X1
Default	00h	0	0	0	0	0	0	0	0

D5 : X6 X6 is fixed as constant current mode.
 [0] : Normal matrix operation (default)
 [1] : X6 is fixed as constant current mode. The LED A6's current setting is used.

D4 : X5 X5 is fixed as constant current mode.
 [0] : Normal matrix operation (default)
 [1] : X5 is fixed as constant current mode. The LED A5's current setting is used.

D3 : X4 X4 is fixed as constant current mode.
 [0] : Normal matrix operation (default)
 [1] : X4 is fixed as constant current mode. The LED A4's current setting is used.

D2 : X3 X3 is fixed as constant current mode.
 [0] : Normal matrix operation (default)
 [1] : X3 is fixed as constant current mode. The LED A3's current setting is used.

D1 : X2 X2 is fixed as constant current mode.
 [0] : Normal matrix operation (default)
 [1] : X2 is fixed as constant current mode. The LED A2's current setting is used.

D0 : X1 X1 is fixed as constant current mode.
 [0] : Normal matrix operation (default)
 [1] : X1 is fixed as constant current mode. The LED A1's current setting is used.

• Please refer to page 38 for details.

OPERATION (Continued)

3. Register map Detailed Explanation (Continued)

Register Name		CONSTX10_7							
Address	R/W	D7	D6	D5	D4	D3	D2	D1	D0
2Dh	R/W	--	--	--	--	X10	X9	X8	X7
Default	00h	0	0	0	0	0	0	0	0

- D3 : X10 X10 is fixed as constant current mode.
[0] : Normal matrix operation (default)
[1] : X10 is fixed as constant current mode. The LED I1's current setting is used.

- D2 : X9 X9 is fixed as constant current mode.
[0] : Normal matrix operation (default)
[1] : X9 is fixed as constant current mode. The LED A9's current setting is used.

- D1 : X8 X8 is fixed as constant current mode.
[0] : Normal matrix operation (default)
[1] : X8 is fixed as constant current mode. The LED A8's current setting is used.

- D0 : X7 X7 is fixed as constant current mode.
[0] : Normal matrix operation (default)
[1] : X7 is fixed as constant current mode. The LED A7's current setting is used.

• Please refer to page 38 for details.

OPERATION (Continued)

3. Register map Detailed Explanation (Continued)

Register Name		CONSTY6_1							
Address	R/W	D7	D6	D5	D4	D3	D2	D1	D0
2Eh	R/W	--	--	Y6	Y5	Y4	Y3	Y2	Y1
Default	00h	0	0	0	0	0	0	0	0

D5 : Y6 Z6 output is fixed to High (VCC level).
[0] : Normal matrix operation (default)
[1] : Switch between VCC and Z6 turns on (VCC level).

D4 : Y5 Z5 output is fixed to High (VCC level).
[0] : Normal matrix operation (default)
[1] : Switch between VCC and Z5 turns on (VCC level).

D3 : Y4 Z4 output is fixed to High (VCC level).
[0] : Normal matrix operation (default)
[1] : Switch between VCC and Z4 turns on (VCC level).

D2 : Y3 Z3 output is fixed to High (VCC level).
[0] : Normal matrix operation (default)
[1] : Switch between VCC and Z3 turns on (VCC level).

D1 : Y2 Z2 output is fixed to High (VCC level).
[0] : Normal matrix operation (default)
[1] : Switch between VCC and Z2 turns on (VCC level).

D0 : Y1 Z1 output is fixed to High (VCC level).
[0] : Normal matrix operation (default)
[1] : Switch between VCC and Z1 turns on (VCC level).

• Please refer to page 38 for details.

OPERATION (Continued)

3. Register map Detailed Explanation (Continued)

Register Name		CONSTY9_7							
Address	R/W	D7	D6	D5	D4	D3	D2	D1	D0
2Fh	R/W	--	--	--	--	--	Y9	Y8	Y7
Default	00h	0	0	0	0	0	0	0	0

D2 : Y9 Z9 output is fixed to High (VCC level).
 [0] : Normal matrix operation (default)
 [1] : Switch between VCC and Z9 turns on (VCC level).

D1 : Y8 Z8 output is fixed to High (VCC level).
 [0] : Normal matrix operation (default)
 [1] : Switch between VCC and Z8 turns on (VCC level).

D0 : Y7 Z7 output is fixed to High (VCC level).
 [0] : Normal matrix operation (default)
 [1] : Switch between VCC and Z7 turns on (VCC level).

• Please refer to page 38 for details.

OPERATION (Continued)

3. Register map Detailed Explanation (Continued)

Register Name		MASKY6_1							
Address	R/W	D7	D6	D5	D4	D3	D2	D1	D0
30h	R/W	--	--	Y6MSK	Y5MSK	Y4MSK	Y3MSK	Y2MSK	Y1MSK
Default	00h	0	0	0	0	0	0	0	0

D5 : Y6MSK Z6 output is fixed to OFF.
 [0] : Normal matrix operation (default)
 [1] : Switch between VCC and Z6 turns off.

D4 : Y5MSK Z5 output is fixed to OFF.
 [0] : Normal matrix operation (default)
 [1] : Switch between VCC and Z5 turns off.

D3 : Y4MSK Z4 output is fixed to OFF.
 [0] : Normal matrix operation (default)
 [1] : Switch between VCC and Z4 turns off.

D2 : Y3MSK Z3 output is fixed to OFF.
 [0] : Normal matrix operation (default)
 [1] : Switch between VCC and Z3 turns off.

D1 : Y2MSK Z2 output is fixed to OFF.
 [0] : Normal matrix operation (default)
 [1] : Switch between VCC and Z2 turns off.

D0 : Y1MSK Z1 output is fixed to OFF.
 [0] : Normal matrix operation (default)
 [1] : Switch between VCC and Z1 turns off.

• Please refer to page 38 for details.

OPERATION (Continued)

3. Register map Detailed Explanation (Continued)

Register Name		MASKY9_7							
Address	R/W	D7	D6	D5	D4	D3	D2	D1	D0
31h	R/W	--	--	--	--	--	Y9MSK	Y8MSK	Y7MSK
Default	00h	0	0	0	0	0	0	0	0

D2 : Y9MSK Z9 output is fixed to OFF.
[0] : Normal matrix operation (default)
[1] : Switch between VCC and Z9 turns off.

D1 : Y8MSK Z8 output is fixed to OFF.
[0] : Normal matrix operation (default)
[1] : Switch between VCC and Z8 turns off.

D0 : Y7MSK Z7 output is fixed to OFF.
[0] : Normal matrix operation (default)
[1] : Switch between VCC and Z7 turns off.

• Please refer to page 38 for details.

OPERATION (Continued)

3. Register map Detailed Explanation (Continued)

Register Name		SLPTIME							
Address	R/W	D7	D6	D5	D4	D3	D2	D1	D0
32h	R/W	--	--	--	FADTIM	SLOPEEXTL[1:0]		SLOPEEXTH[1:0]	
Default	00h	0	0	0	0	0	0	0	0

D4 : FADTIM Fade out time control.
 [0] : $T3 = T1$ (default)
 [1] : $T3 = T1 \times 2$

- This bit also affect in PWM fade out mode. Fade out time becomes 2 times of fade in time when FADTIM = 1.

D3-2: SLOPEEXTL T4 time extent control.
 [00] : $T4 = T1$ (default)
 [01] : $T4 = T1 \times 0.25$
 [10] : $T4 = T1 \times 0.5$
 [11] : $T4 = T1 \times 2$

D1-0: SLOPEEXTH T2 time extent control.
 [00] : $T2 = T1$ (default)
 [01] : $T2 = T1 \times 0.25$
 [10] : $T2 = T1 \times 0.5$
 [11] : $T2 = T1 \times 2$

- T1 time is controlled by the register #91h to #E1h.

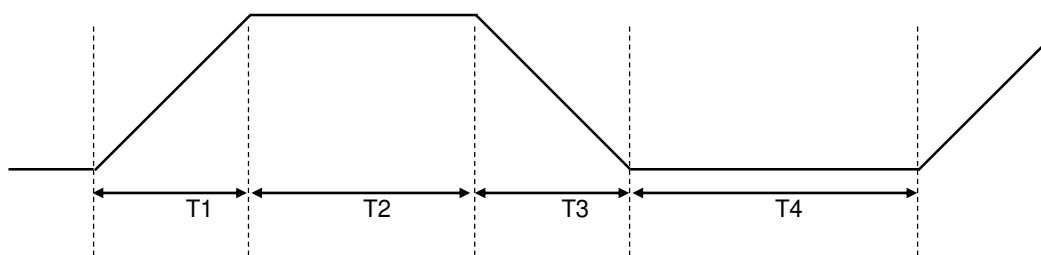

OPERATION (Continued)

3. Register map Detailed Explanation (Continued)

Register Name		MLDCOM							
Address	R/W	D7	D6	D5	D4	D3	D2	D1	D0
33h	R/W	--	--	--	--	--	MLDCOM[2:0]		
Default	03h	0	0	0	0	0	0	1	1

D2-0 : MLDCOM LED Turn on time compensation in melody mode

- [000] : 0s
- [001] : 1.94 μ s
- [010] : 3.87 μ s
- [011] : 5.80 μ s (default)
- [100] : 7.74 μ s
- [101] : 9.67 μ s
- [110] : 11.6 μ s
- [111] : 13.5 μ s

Register Name		SCANSET							
Address	R/W	D7	D6	D5	D4	D3	D2	D1	D0
36h	R/W	--	--	--	--	SCANSET[3:0]			
Default	08h	0	0	0	0	1	0	0	0

D3-0 : SCANSET SCAN number control

- [0000] : Only scan the first column.
- [0001] : Only scan the first 2 column.
- [0010] : Only scan the first 3 column.
- [0011] : Only scan the first 4 column.
- [0100] : Only scan the first 5 column.
- [0101] : Only scan the first 6 column.
- [0110] : Only scan the first 7 column.
- [0111] : Only scan the first 8 column.
- [1000] : Scan all column. (default)

- All other values will scan all column.

OPERATION (Continued)

3. Register map Detailed Explanation (Continued)

Register Name		DTA1							
Address	R/W	D7	D6	D5	D4	D3	D2	D1	D0
40h	R/W	DTA1[7:0]							
Default	00h	0	0	0	0	0	0	0	0

D7-0: DTA1 A1 PWM duty control.
 [0000_0000] : 0%. (default)
 [0000_0001] : 0.39%. (1/256)
 [0000_0010] : 0.78%. (2/256)
 [0000_0011] : 1.17%. (3/256)
 ...
 [1111_1100] : 98.8%. (253/256)
 [1111_1110] : 99.2%. (254/256)
 [1111_1111] : 99.6%. (255/256)

- This duty setting is only effective when PWMA1 is High.
- The definition for register addresses #41h to #90h is the same as address #40h.

OPERATION (Continued)

3. Register map Detailed Explanation (Continued)

Register Name		A1							
Address	R/W	D7	D6	D5	D4	D3	D2	D1	D0
91h	R/W	BRTA1[3:0]				--	SDTA1[2:0]		
Default	00h	0	0	0	0	0	0	0	0

D7-4: BRTA1 Luminance set up of LED A1 (in case of IMAX [2:0] = [011])

- [0000] : 0 mA (default)
- [0001] : 2 mA
- [0010] : 4 mA
- [0011] : 6 mA
- [0100] : 8 mA
- [0101] : 10 mA
- ...
- [1010] : 20 mA
- [1011] : 22 mA
- [1100] : 24 mA
- [1101] : 26 mA
- [1110] : 28 mA
- [1111] : 30 mA

D2-0: SDTA1 (SCANSET = [11], default setting)

(1) Firefly Operation (PWMA1 = 0)

- [000] : Constant current mode (default)
- [001] : 0.248 s
- [010] : 0.495 s
- [011] : 0.99 s
- [100] : 1.484 s
- [101] : 1.979 s
- [110] : 2.473 s
- [111] : 2.968 s

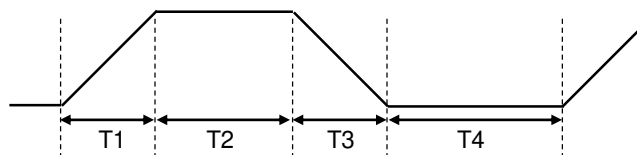

(2) PWM Fade-in/out Operation (PWMA1 = 1)

- [000] : Instant change mode (default)
- [001] : 1.939 ms
- [010] : 3.879 ms
- [011] : 7.758 ms
- [100] : 11.636 ms
- [101] : 15.515 ms
- [110] : 19.394 ms
- [111] : 23.273 ms

- In case of PWM duty change from 0 to 255, the longest time is $255 \times 23.273 \text{ ms} = 5.957 \text{ s}$.
- T1 time is also controlled by SCANSET in register #36h. The calculation method is as follow:
 - SCANSET = 0000 : $T1 = 0.111 \times T_{\text{default}}$
 - SCANSET = 0001 : $T1 = 0.222 \times T_{\text{default}}$
 - ...
 - SCANSET = 0111 : $T1 = 0.888 \times T_{\text{default}}$
- The definition for register addresses #92h to #E1h is the same as address #91h.

OPERATION (Continued)

4. Operation Mode priority

MTXON	X*	Y*MSK	Y*	PWM*	SDT*	Operation Mode
0	x	x	x	x	x	OFF
1	1	x	x	x	x	X*CNT constant mode
1	0	1	x	x	x	OFF
1	0	0	1	x	x	Turn on with all A1, A2, A3, A4
1	0	0	0	1	x	PWM mode
1	0	0	0	0	!=0	Blinking mode
1	0	0	0	0	0	Constant current mode

• * for X*, PWM*, SDT* = 1 ~ 10, * for Y*MSK, Y* = 1 ~ 9.

OPERATION (Continued)

5. I²C Bus Interface

5.1 Basic Rules

- This IC, I²C-bus, is designed to correspond to the Standard-mode (100 kbps), Fast-mode(400 kbps) and Fast-mode plus (1 000 kbps) devices in the version 03 of NXP's specification. However, it does not correspond to the H_S-mode (to 3.4 Mbps).
- This IC will operate as a slave device in the I²C-bus system. This IC will not operate as a master device.
- The program operation check of this IC has not been conducted on the multi-master bus system and the mix-speed bus system, yet. The connected confirmation of this IC to the CBUS receiver also has not been checked. Please confirm with our company if it will be used in these mode systems.
- The I²C is the brand of NXP.

5.2 START and STOP conditions

When SDA signal changes from "High" to "Low" while SCL is "High" will trigger START condition. Whereas, STOP condition will be triggered when SDA signal changes from "Low" to "High" while SCL is "High". START condition and STOP condition are always formed by the master. After the START condition occurs, the bus becomes busy state. After STOP condition occurs, the bus becomes free again.

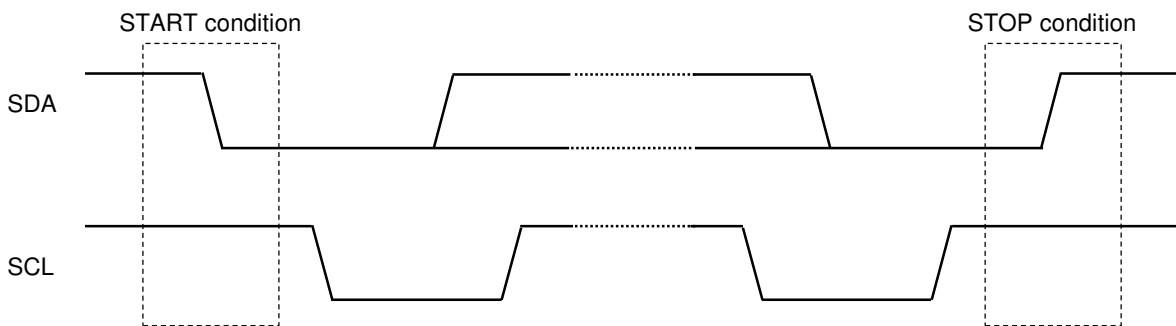

5.3 Data Transfer

Length of each byte output to SDA line is always 8 bits. There is no limitation in the number of bytes that can be transmitted at 1 time. Many bytes can be sent. The acknowledge bit is necessary for each byte. Data is sequentially transmitted from most significant bit (MSB).

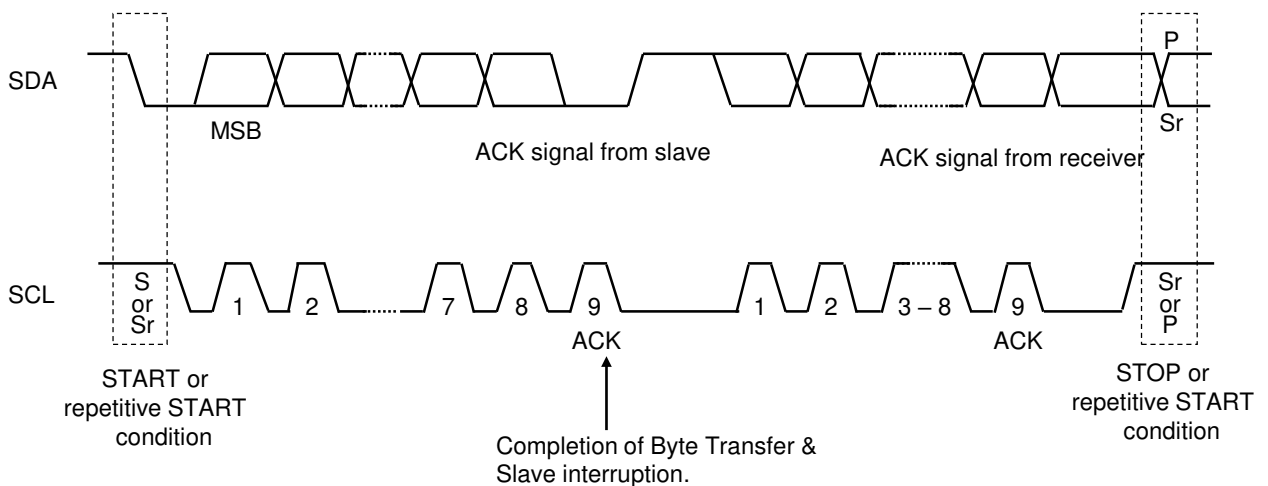

OPERATION (Continued)

5. I²C Bus Interface (Continued)

5.4 I²C Interface - Data Format

In this IC, 4 different Slave addresses can be changed by selecting SLAVSEL ("Low" or "High" or "SCL" or "SDA"). The slave addresses of this IC are as follow:

SLAVSEL	Slave address
Low	1011 100X
High	1011 101X
SCL	1011 110X
SDA	1011 111X

• Write mode

Sub address is not incremented automatically.
The next data byte is written in the same Sub address by transmitting data byte continuously.

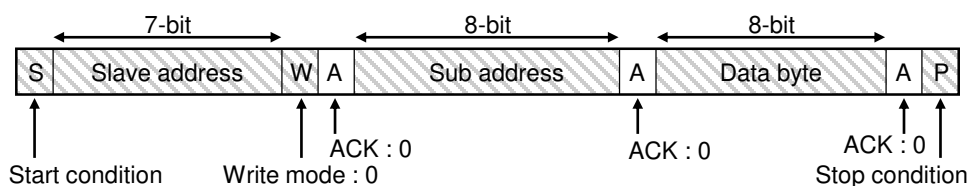

• Write mode (Auto increment mode)

Data byte can be written in Sub address by transmitting data byte continuously.
Sub address is incremented automatically.

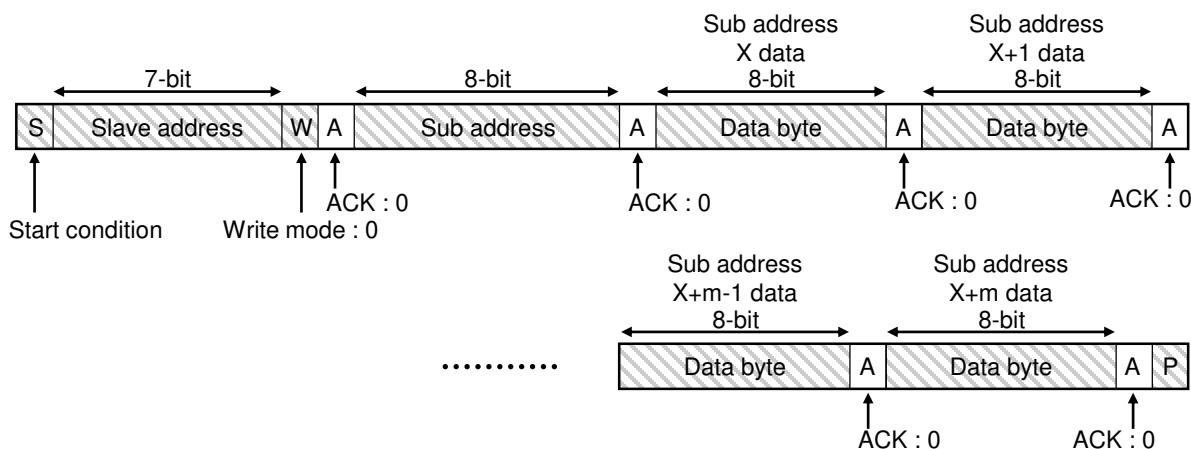

▨ : Data transmission from Master
□ : Data transmission from Slave

OPERATION (Continued)

5. I²C Bus Interface (Continued)

5.4 I²C Interface - Data Format (Continued)

- Read mode (in case Sub address is not specified)

When Sub address 8 bit is not specified and data is read, this IC allows to read the value of adjacent Sub address specified in the last Write mode.
The next data byte reads the same Sub address by transmitting data byte continuously.

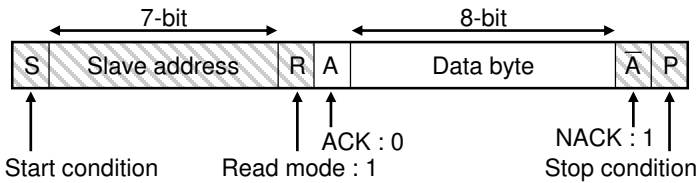

- Read mode (in case Sub address is specified)

Sub address is not incremented automatically.
The next data byte reads the same Sub address by transmitting data byte continuously.

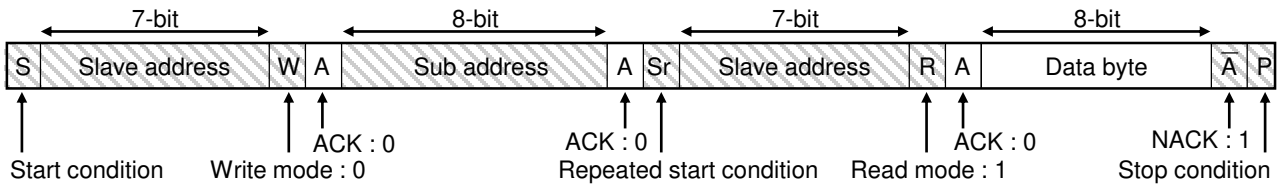

- Read mode (Auto increment mode)

It is possible to read data byte in continuous Sub address by transmitting data byte continuously.
Sub address is incremented automatically.

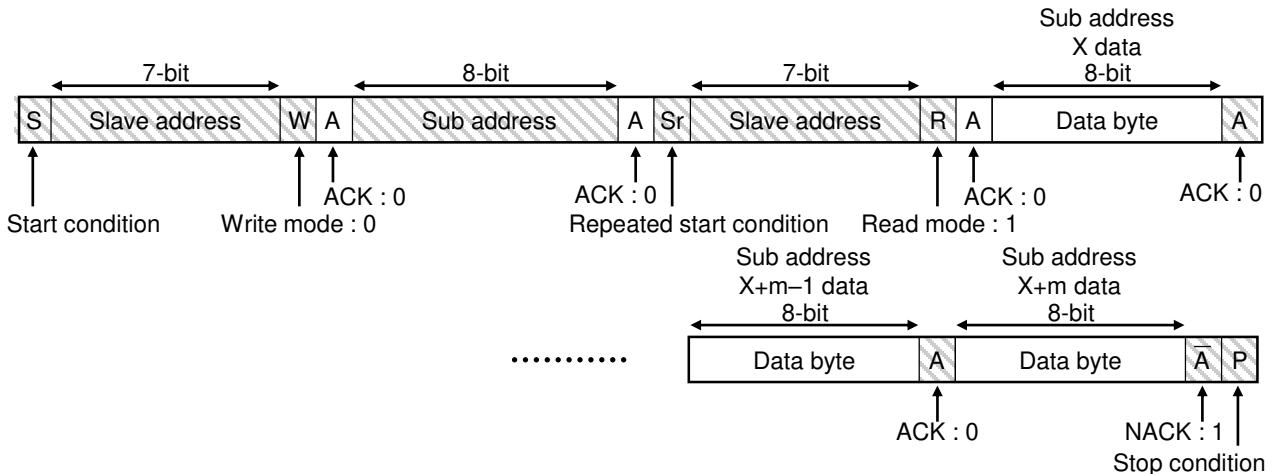

▨ : Data transmission from Master
□ : Data transmission from Slave

OPERATION (Continued)

6. Signal distribution diagram

6.1 Distribution diagram of power supply

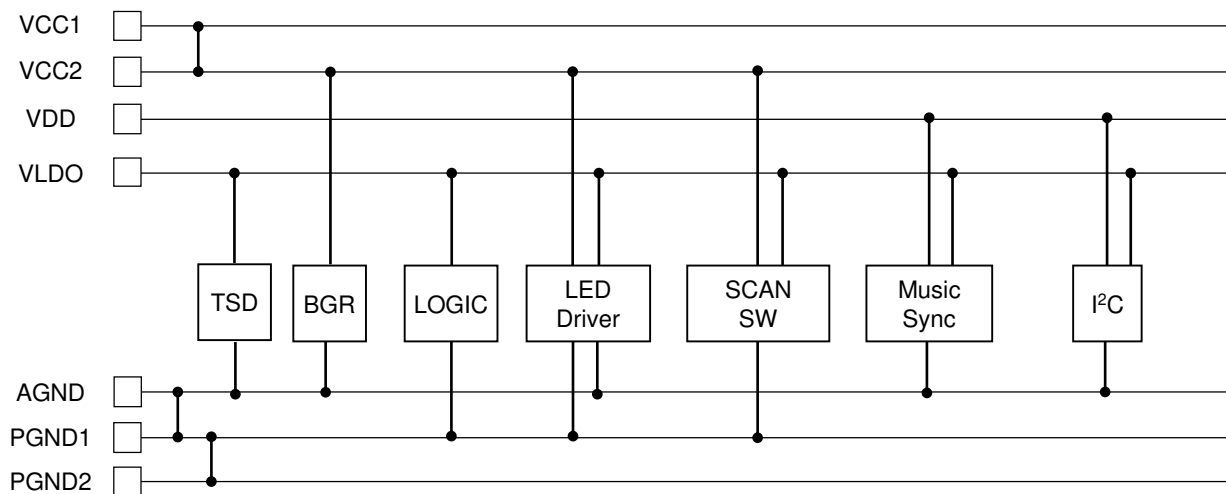

6.2 Distribution diagram of control / clock system

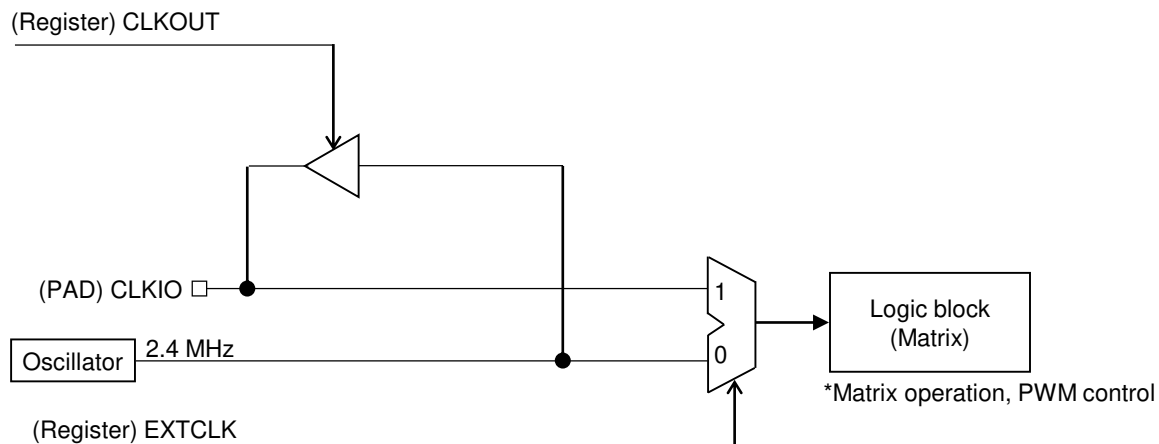

OPERATION (Continued)

7. Block Configuration of Matrix LED

7.1 Matrix LED descriptions, Matrix LED's numbers

LED matrix driver circuit individually drives LED of 9×9 matrix. In total, the IC can drive and light up 81 LED. In this specification, LED's number controlled by each pin corresponds as follows.

The internal logic circuit is operated by using an internal clock or the external clock input to the terminal CLKIO.

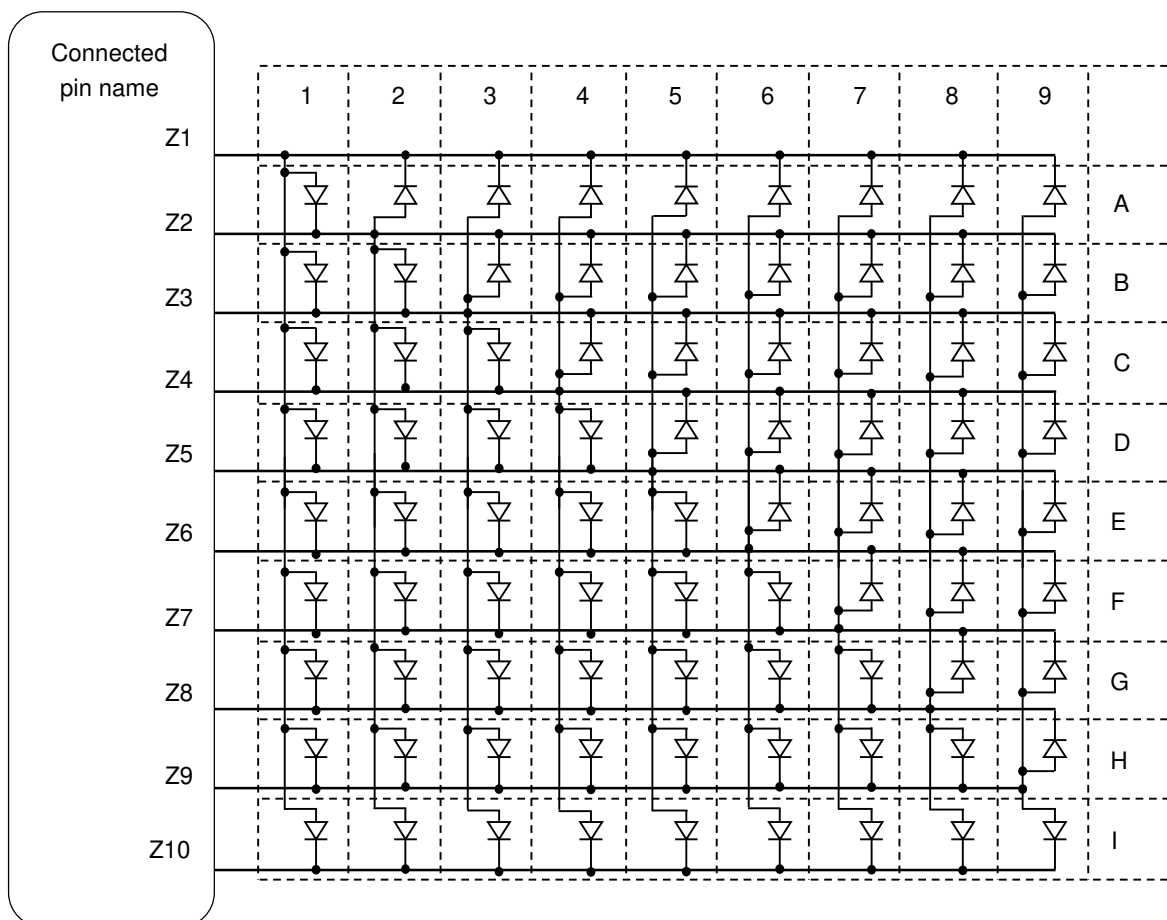

OPERATION (Continued)

7. Block Configuration of Matrix LED (Continued)

7.2 Driver Configuration

- Actual driver configuration is shown in the following figure.
- The anode and cathode of each LED are connected to different Z pin as shown in figure below.
- Z10 pin consists of only Current Sink and Slope control timing driver. Thus, LED anodes are not to be connected to Z10 pin.
- Please do not remove any of the LED inside the matrix if it is not used. If LED are to be removed, it is advised to remove the entire row (e.g: all LED in row A) instead of removing only 1 LED. If only one LED in the row is removed instead of the whole row, user needs to avoid using LED of which reverse breakdown voltage is lower than the operating V_{CC} level.
- Internal control logic according to user register settings is used to control Y1 to Y9CNT(PMOS ON/OFF Scan Switches) as well as X1 to X10CNT (Current sink value as well as PWM/Slope timing for lighting effects)

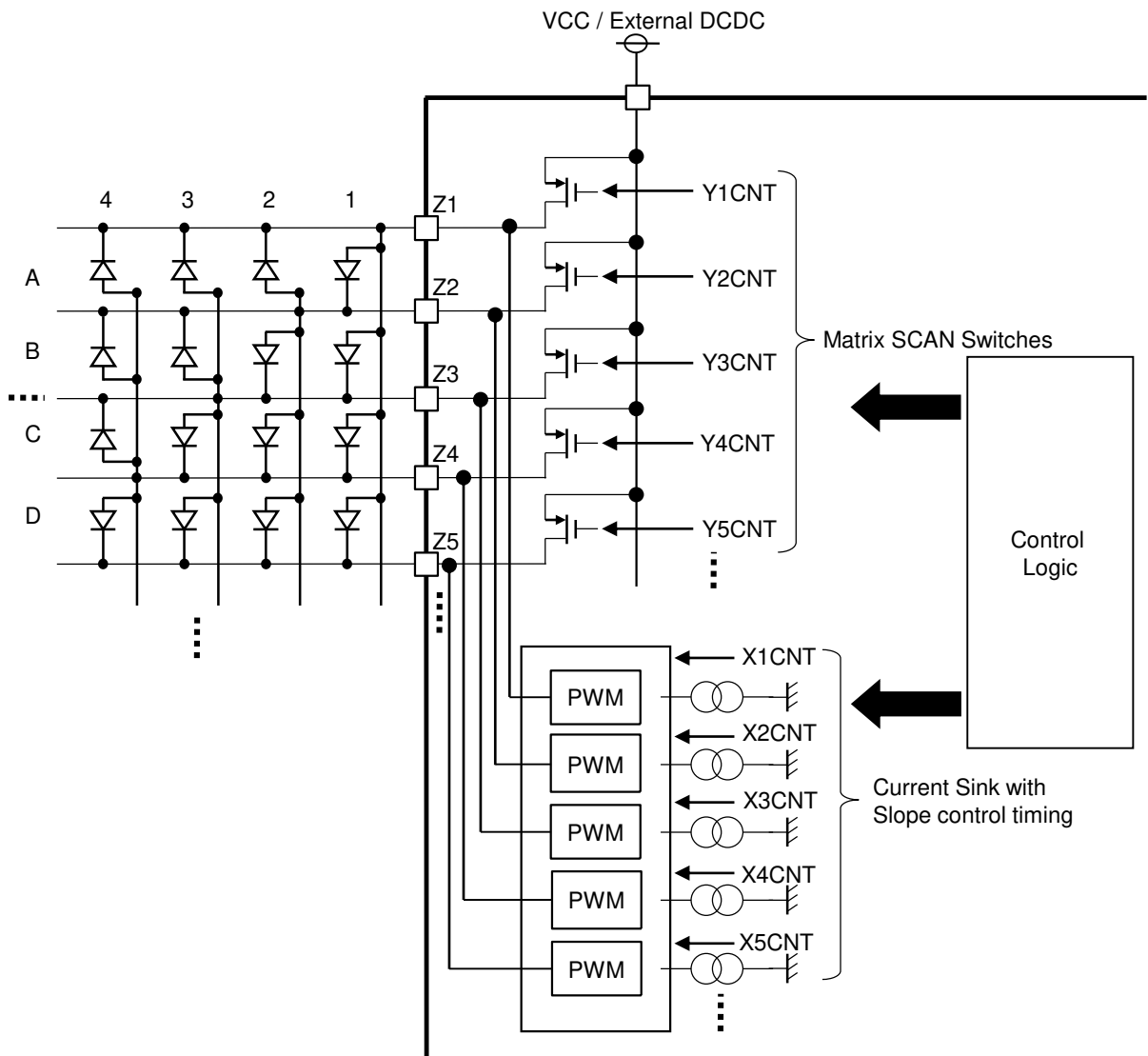

OPERATION (Continued)

7. Block Configuration of Matrix LED (Continued)

7.3 Timing Chart when in operation

- The figure below shows the timing chart when in operation.
- Timing can be controlled according to the external clock frequency input to CLKIO pin.
- In default condition, it is controlled by internal 2.4 MHz clock.
- Y1 to Y9CNT are scan timing which is turned on one at a time. The ON period of each pin is constant 255 clks (106.08 μ s) and includes the interval of 4 clks (1.664 μ s).
- 81 LED (9 \times 9 matrix) are controlled by X1 to X10CNT according to below figure.
- When Y*CNT = "High", X*CNT = "Low", the actual waveform of Z* is set to Hi-Z.

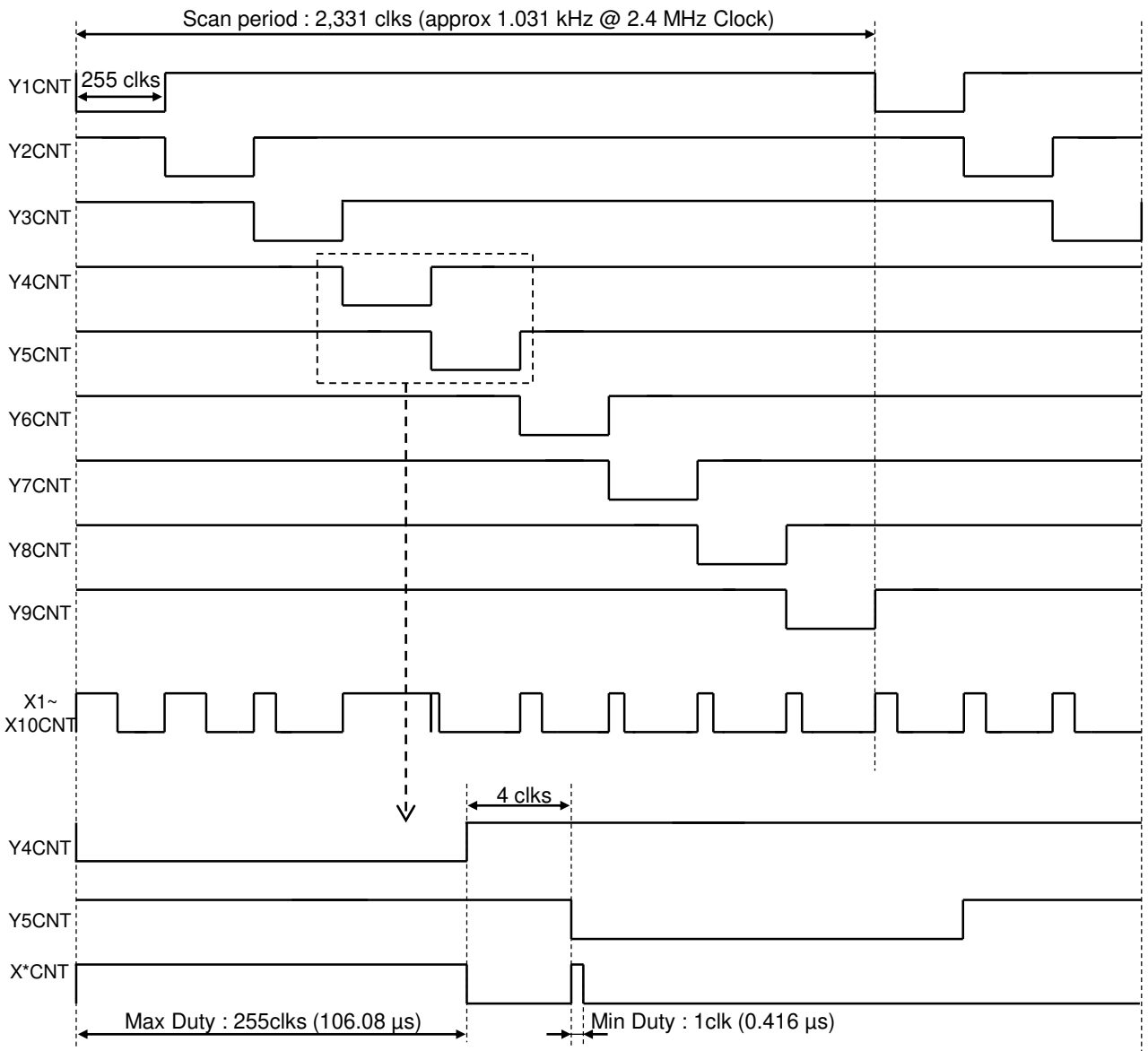

- Duty can be set using register DT*[7:0] from registers #40h to #90h. Additional brightness control is provided through register BRT*[3:0] (registers #91h to #E1h).

OPERATION (Continued)

8. LED Driver Block Function

- Functions Table for LED Driver

No.	Features	Setting Range
1	Constant current mode	IMAX Setting : 7.5 mA to 60 mA (max) DAC Current Step (Brightness) : 0.5 mA to 4 mA (max) step
2	PWM mode and Fade-in/out mode	IMAX Setting : 7.5 mA to 60 mA (max) DAC Current Step (Brightness) : 0.5 mA to 4 mA (max) step Adjustable detention Time for each step : (1.939 ms to 23.273 ms / step)
3	Firefly mode	Fixed Current at 100% Duty IMAX Setting : 7.5 mA to 60 mA (max) DAC Current Step (Brightness) : 0.5 mA to 4 mA (max) step Adjustable detention Time for each step : (0.248 s to 2.968 s / step)
4	Melody mode	IMAX Setting : 7.5 mA to 60 mA (max) DAC Current Step (Brightness) : 0.5 mA to 4 mA (max) step Each LED can synchronize with Music Input from CLKIO pin
5	Bar Meter Mode	IMAX Setting : 7.5 mA to 60 mA (max) DAC Current Step (Brightness) : 0.5 mA to 4 mA (max) step Group LED can synchronize with Music Input from CLKIO pin Bar Meter Mode has more priority than Melody mode.

8.1 Constant Current Mode

Maximum current setting value can be set up as 60mA using register IMAX[2:0] (register 05h). Brightness can be set through the register BRT*[3:0] (register #91h to #E1h) for individual LED.

Example)

E.g. If user sets register IMAX[2:0](#05h) = 011 and BRT*[3:0](#91h to #E1h) = 1111, the current will be 30 mA.

E.g. If user sets register IMAX[2:0](#05h) = 111 and BRT*[3:0](#91h to #E1h) = 1111, the current will be 60 mA.

E.g. If user sets register IMAX[2:0](#05h) = 111 and BRT*[3:0](#91h to #E1h) = 0111, the current will be 28 mA.



OPERATION (Continued)

8. LED Driver Block Function (Continued)

8.2 PWM Mode and Fade-in/out Mode

This operation is characterized by PWM signal having variable duty depending on register DT*[7:0] (registers #40h to #90h). However, any changes in duty are not instantaneous, but rather it will step to the new duty at time determined by register SDT*[2:0].

Example)

Case 1 : LED*DT(new) > LED*DT(old) (PWM Mode without Fade in/out control)

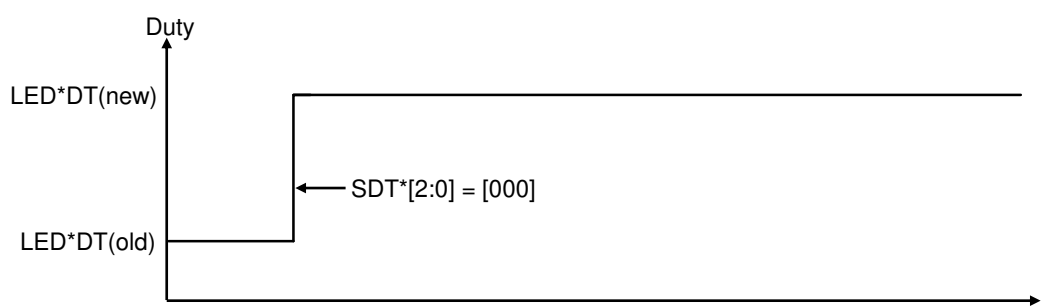

In Case 1, PWM duty has been changed from low to high duty. But the register SDT*[2:0] setting is [000] indicating that there is no Fade in/out control. Therefore, PWM duty changes instantaneously. Users can see that LED becomes brighter instantaneously once PWM duty has been changed.

Case 2 : LED*DT(new) > LED*DT(old) (PWM Mode with Fade in control)

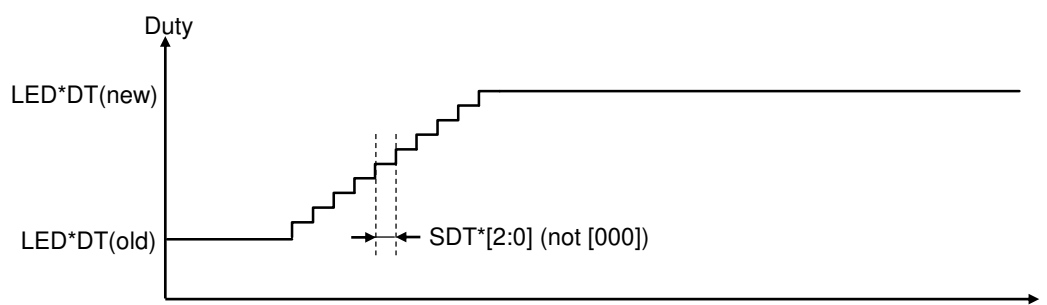

In Case 2, PWM duty has also been changed from low to high duty. Unlike in case 1, the register SDT*[2:0] setting is not [000] in case 2. Therefore, PWM duty has changed according to the register SDT*[2:0] setting. This is called PWM mode with Fade in control. Users can see that LED becomes brighter slowly according to the timing set in register SDT*[2:0].

OPERATION (Continued)

8. LED Driver Block Function (Continued)

8.2 PWM Mode and Fade-in/out Mode (Continued)

Example) (continued)

Case 3 : $LED*DT (new) < LED*DT (old)$ (PWM Mode with Fade out control), $FADTIM = [0]$

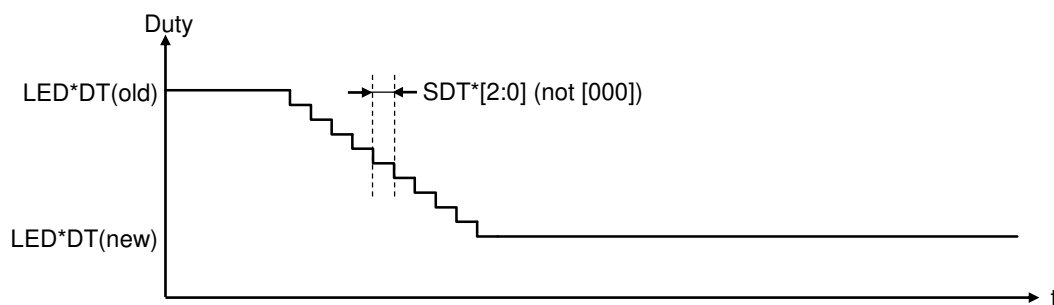

In Case 3, PWM duty has been changed from high to low duty. Unlike in case 1, the register $SDT*[2:0]$ setting is not [000] in case 3. Therefore, PWM duty has changed according to the register $SDT*[2:0]$ setting. This is called PWM mode with Fade out control. Users can see that LED becomes dimmer slowly according to the timing set in register $SDT*[2:0]$.

Case 4 : $LED*DT (new) < LED*DT (old)$ (PWM Mode with Fade out control), $FADTIM = [1]$

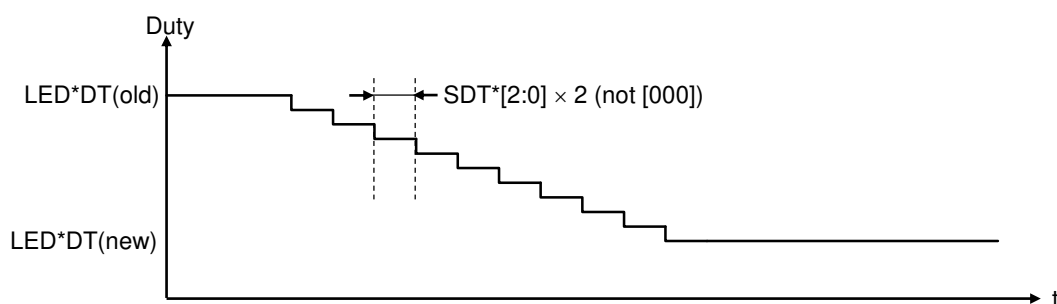

In Case 4, PWM duty has also been changed from high to low duty. Unlike in case 3, the register $FADTIM$ is not [0]. Again, the register $SDT*[2:0]$ setting is also not [000] in case 4. PWM duty has changed according to the register $SDT*[2:0]$ setting. Users can see that LED becomes dimmer slowly. It is slower than Case3 as $FADTIM$ register is high (2 times slower than Case 3 Fade out control).

$DT*[7:0]$ is set through register #40h to #90h. $FADTIM$ is set through register #32h. $SDT*[2:0]$ is set through register #91h to #E1h.

OPERATION (Continued)

8. LED Driver Block Function (Continued)

8.3 Firefly Control

This operation is characterized by PWM signal cycling from minimum to maximum duty and vice versa with auto repeat function at time step determined by register SDT*[2:0]. Unlike PWM Fade in/out mode, firefly is auto repetition of the sequence and thus creating LED blinking function effect.

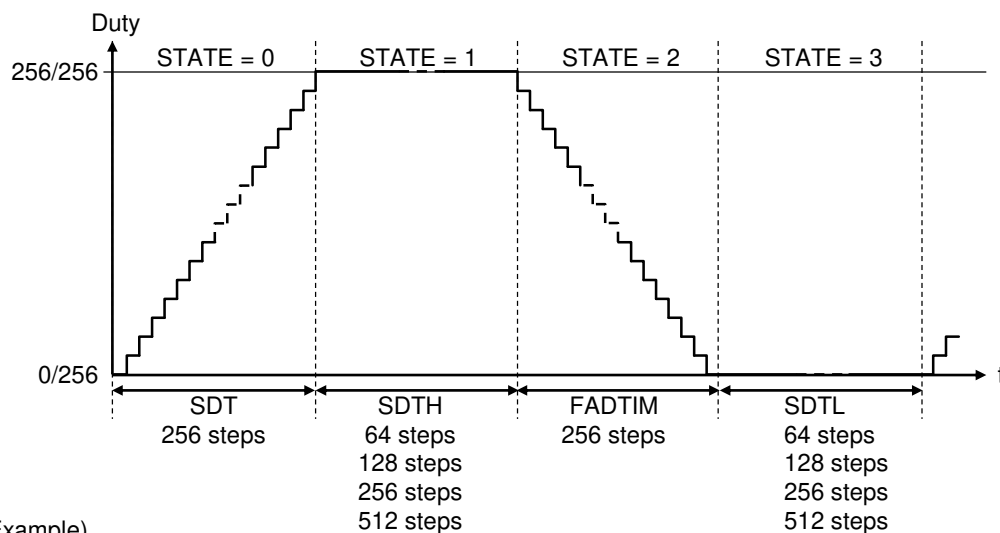

Example)

Example 1 : SDTH = 00 (SDT × 1), SDTL = 00 (SDT × 1), FADTIM = 0

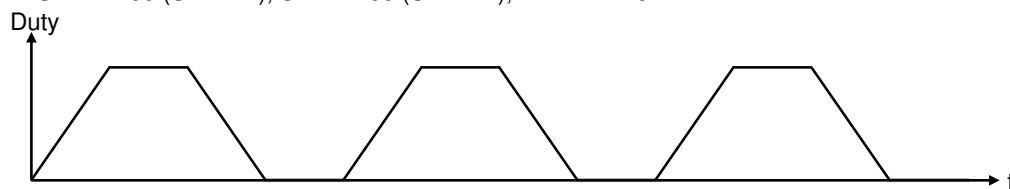

Example 2 : SDTH = 00 (SDT × 1), SDTL = 00 (SDT × 1), FADTIM = 1 (SDT × 2)

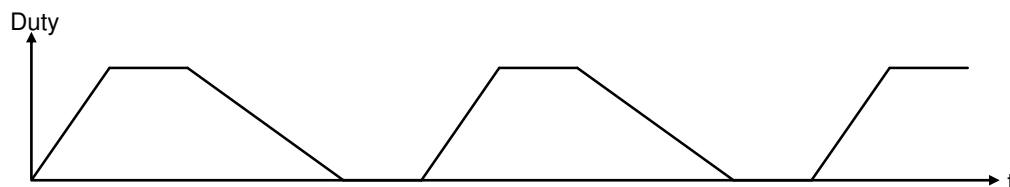

Example 3 : SDTH = 01 (SDT × 0.25), SDTL = 11 (SDT × 2), FADTIM = 0

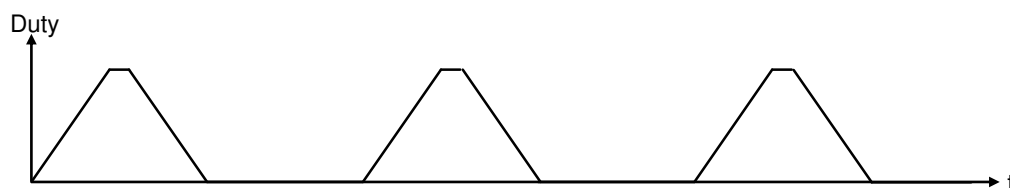

The SDTH is controlled by SLOPEEXTH[1:0] register, SDTL is controlled by SLOPEEXTL[1:0] register. All these register, SLOPEEXTH[1:0], SLOPEEXTL[1:0] and FADTIM can be set through register #32h. SDT*[2:0] registers are set individually through register #91h to #E1h. All other combinations of SDTH, SDTL and FADTIM is possible.

OPERATION (Continued)

8. LED Driver Block Function (Continued)

8.4 Melody Mode Explanation

Melody mode is to synchronize LED to external music signal. Melody mode can be set through register MLDACT from register 04h. Each of the 16 LED matrix can be individually enabled for external music synchronization through register data (address #08h to #09h when register address 04h is set as data 04h).

External Music Signal can be injected from CLKIO pin. CLKIO pin serve as both input and output. CLKIO pin can output internal oscillator frequency by using CLKOUT register (register 04h).

CLKIO pin can be used as input for external signal by using EXTCLK register (register 04h). External clock frequency is typically 2.4 MHz. It is advisable to use external clock frequency from 1.2 MHz to 4.8 MHz.

Please do not set MLDACT, EXTCLK and CLKOUT register to "High" at the same time. In such case, the priority of operation will be EXTCLK then CLKOUT and then Melody Mode will have the least priority.

Case 1 : CLKIO as output pin

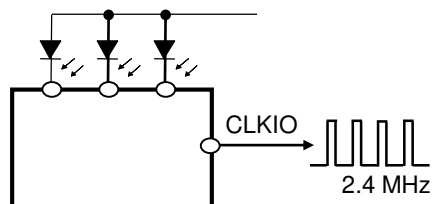

CLKIO output internal frequency by using CLKOUT register

Case 2 : CLKIO as input for external clock

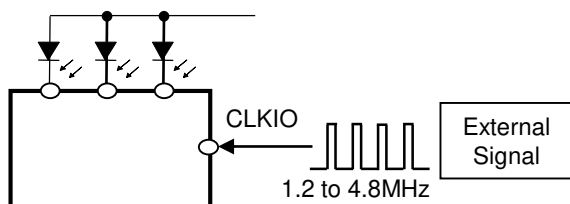

CLKIO uses as external input by using EXTCLK register

Case 3 : CLKIO as input for music signal during melody mode

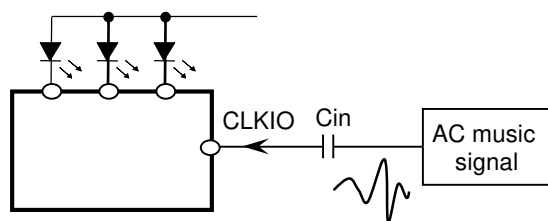

CLKIO uses as music input when melody mode is enabled by register MLDACT from register 04h.

Note : If input CLKIO voltage is higher than VDD, there will be back flow current to VDD. It can be calculated as below :

$$I_{BackFlow} = \frac{(V_{CLKIO} - 0.7 V - VDD)}{393 k\Omega}$$

Note : Cin can be calculated as below : In case of that the applicable music frequency is 20 Hz.

$$Cin \geq \frac{1}{(20 \text{ Hz}) \times 2 \times 3.14 \times 175 k\Omega} = 45.5 \text{ nF}$$

OPERATION (Continued)

8. LED Driver Block Function (Continued)

8.4 Melody Mode Explanation (Continued)

AC music signal input from CLKIO pin will be compared with internal threshold setting. Based on the comparison of music signal and threshold voltage, PWM driver control will change and control the LED ON/OFF. Therefore, LED light ON/OFF control will synchronize with music tempo while LED brightness will synchronize with music loudness. There are two threshold modes, one is auto threshold and the other is fixed threshold mode.

There are 8 threshold voltage levels in this IC as defined in the register 2Bh (THOLD[7:0]). Auto threshold mode means that the 8 threshold voltages will be scanned automatically from the lowest to highest threshold voltages at a fixed frequency higher than audio frequency. Input music signal will be compared with these scanning threshold voltages to control PWM Driver in order to have music synchronization effects. This mode allows user to easily use music synchronize function without having the trouble of manually setting the detection threshold. When melody mode is enabled, auto threshold mode will be the default mode.

Fixed threshold mode means that the threshold voltage is fixed at one threshold level. It can be set using register 2Bh (THOLD[7:0]). Input music signal will be compared with this fixed threshold voltage set by the user. During fixed threshold mode, do not set more than 1 register bit to logic "High" value at the same time. If user set more register bits to logic "High" after setting 1 register bit to "High", system will only recognise the first "High" bit threshold that is set. In this mode, user can have the flexibility to configure different threshold voltage levels to achieve the desired LED music synchronizing visual effect according to the system music input level.

It is also advised that AC music signal peak to peak voltage to be at least 0.35 V and not more than 2.8 V.

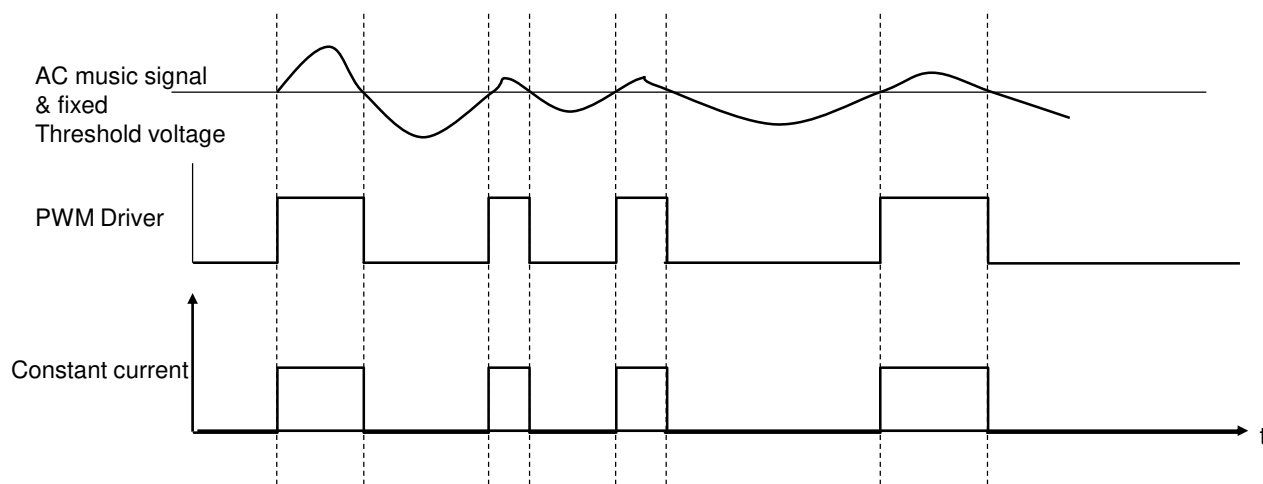

Example of Fixed threshold mode

- Brightness Compensation in Melody Mode

Additional brightness compensation in melody mode can be achieved by increasing or decreasing the turning on period of LED. Using brightness compensation register MLDCOM[2:0] (#33h), LED turning on period can be controlled and LED can become brighter or dimmer.

This additional brightness compensation will be effective only in auto threshold mode. If fixed threshold mode is used, this register will not be able to control LED brightness.

OPERATION (Continued)

8. LED Driver Block Function (Continued)

8.5 Bar Meter Mode Explanation

Bar Meter Mode operation is another method of external melody mode wherein a group of LEDs are used instead of individual LED. Bar Meter Mode has higher priority than individual LED melody mode.

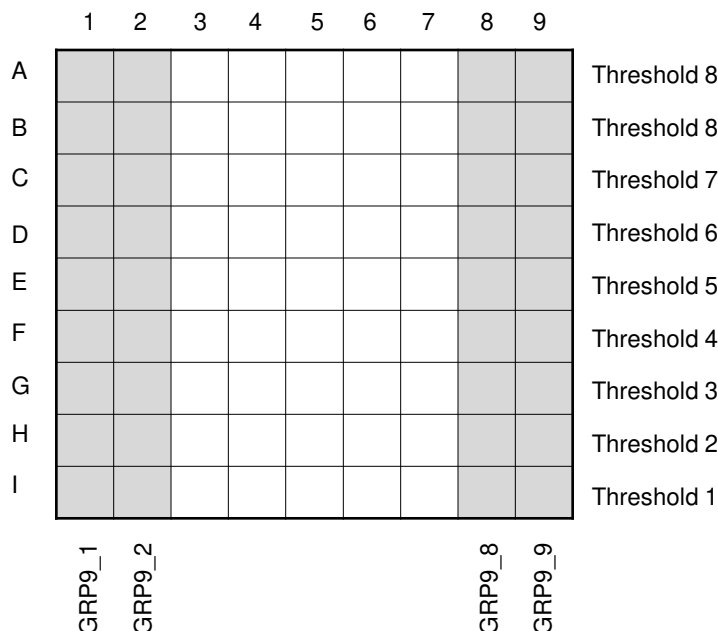

In the above diagram, column 1 = group1, column 2 = group2, column 8 = group8 and column 9 = group9. Each group can be enabled through register GRP9_1, 9_2, 9_8, 9_9 (address #2Ah). The LED in the all groups will be synchronized to threshold signals as follow:

Threshold Signal	Bar Meter Mode Group LED ON
Threshold 1	Row's I
Threshold 2	Row's H, I
Threshold 3	Row's G, H, I
Threshold 4	Row's F, G, H, I
Threshold 5	Row's E, F, G, H, I
Threshold 6	Row's D, E, F, G, H, I
Threshold 7	Row's C, D, E, F, G, H, I
Threshold 8	Row's A, B, C, D, E, F, G, H, I

All other LEDs not in Bar Meter Mode can operate in individual external melody mode or other modes.

During Bar Meter Mode, auto threshold detection should be used. This IC does not support Bar Meter Mode with fixed threshold setting. It is also recommended not to use other modes together with Bar Meter Mode of LED in group 1, 2, 8 & 9 (i.e. LED A to I1, 2, 8, 9)

OPERATION (Continued)

9. Ghost Image Prevention Function

Ghost images sometimes appear during LED matrix mode operation. Very dim light can appear in some LED even during OFF condition. This is called Ghost Image. In this IC, Ghost Image Prevention Function is included to reduce Ghost Image effect. Ghost Image Prevention Function can be enabled through register ZPDEN (register 04h).

- Ghost Image Prevention may not remove the ghost image perfectly. It depends on the LED color combination and LED connection method.

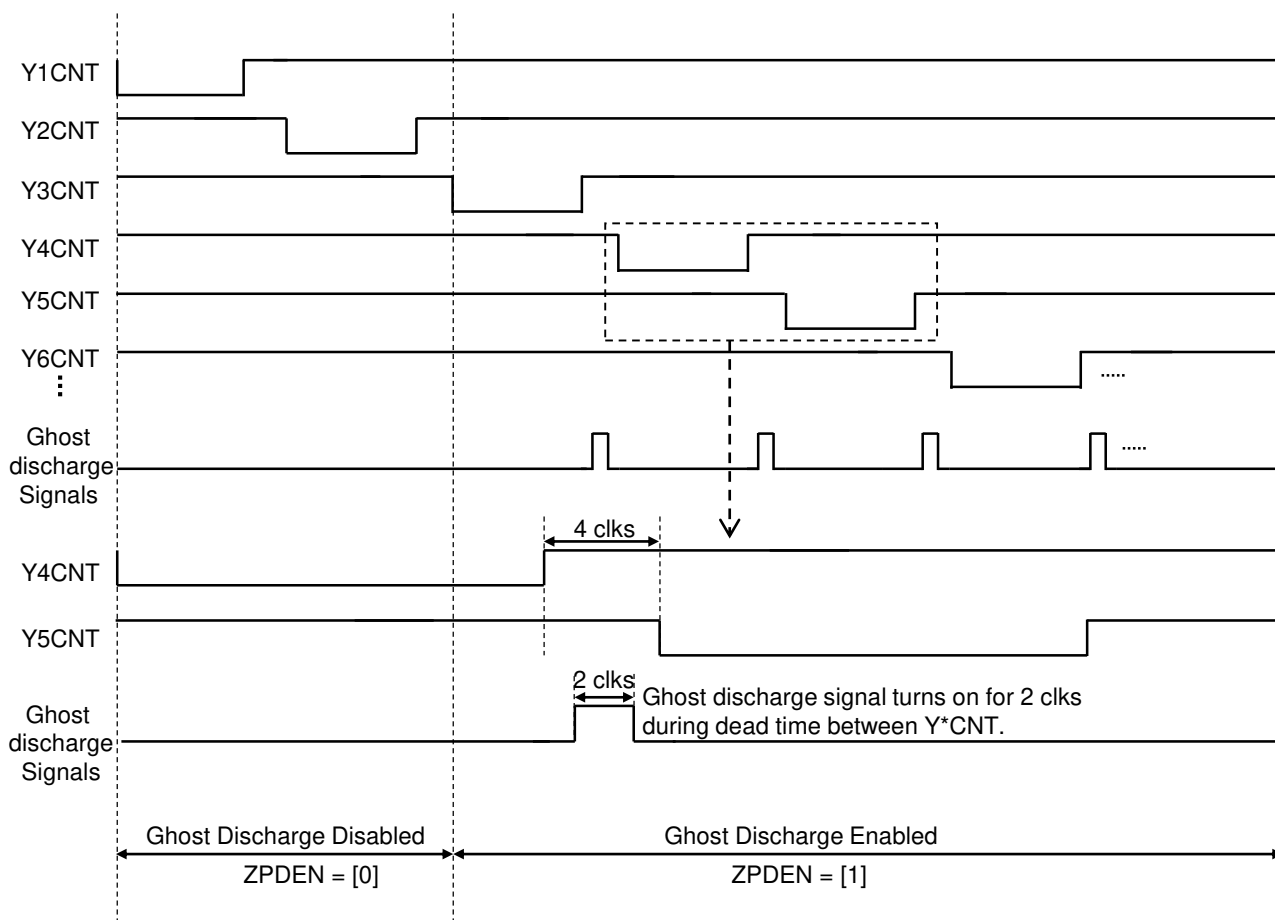

During normal operation, ghost discharge signal will be always low. When ghost image prevention function is enabled through register 04h, ghost discharge signal will turn on for 2 clks cycle during 4 clks dead time between each Y*CNT. During on period of 2 clks cycle, output Z pin will be forced to half of V_{CC} .

OPERATION (Continued)

9. Ghost Image Prevention Function (Continued)

To minimize ghost image, it is recommended to use LED with same forward voltage drop in LED panel. If user wants to use LED with different forward voltage drop in LED panel (e.g. RGB LED in LED panel), it is recommended that all the cathodes of LED connected to the same pin must have same forward voltage drop. (i.e. same colour LED sharing the same cathode). A recommended RGB LED connection to minimize ghost image is shown in diagram below.

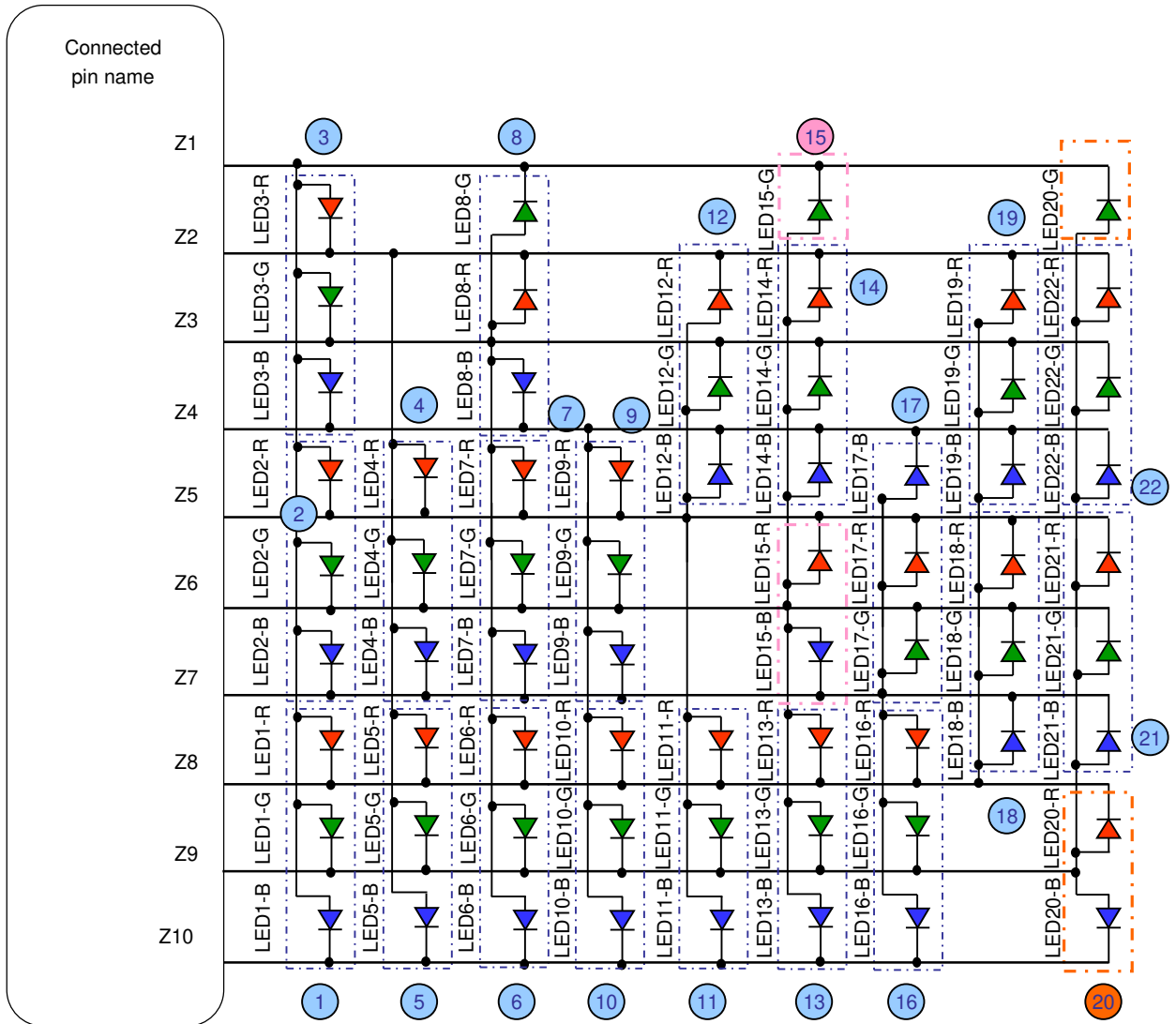

Example of RGB LED connection

PACKAGE INFORMATION (Reference Data)

Unit:mm

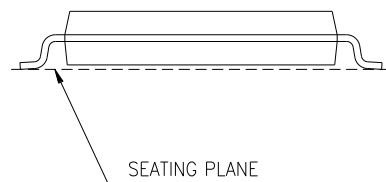
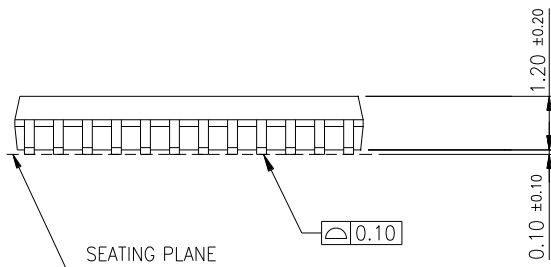
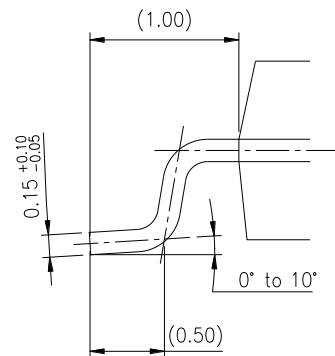
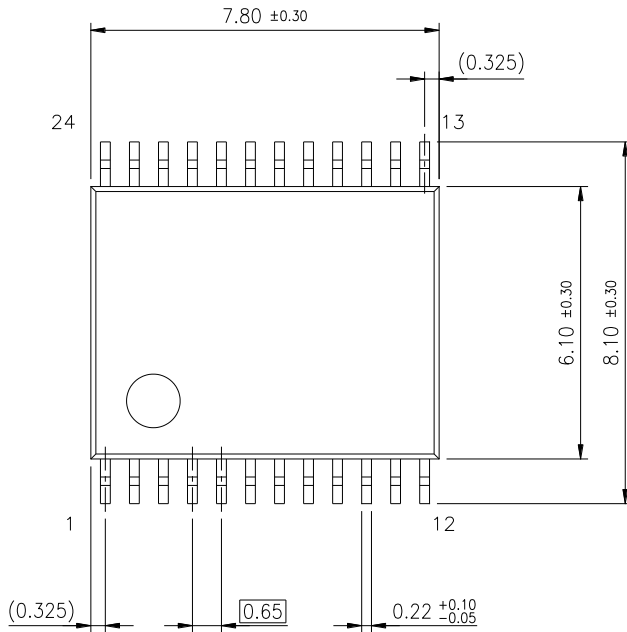

Body Material :	Br/Sb Free Epoxy resin
Lead Material :	Cu Alloy
Lead Finish Method :	SnBi Plating

IMPORTANT NOTICE

1. When using the IC for new models, verify the safety including the long-term reliability for each product.
2. When the application system is designed by using this IC, please confirm the notes in this book.
Please read the notes to descriptions and the usage notes in the book.
3. This IC is neither designed nor intended for use in automotive applications or environments unless the specific product is designated by our company as compliant with the ISO/TS 16949 requirements.
Our company shall not be held responsible for any damage incurred by customers or any third party as a result of or in connection with the IC being used in automotive application, unless our company agrees to such application in this book.
4. Please use this product in compliance with all applicable laws and regulations that regulate the inclusion or use of controlled substances, including without limitation, the EU RoHS Directive. Our company shall not be held responsible for any damage incurred as a result of our IC being used by our customers, not complying with the applicable laws and regulations.

USAGE NOTES

1. Pay attention to the direction of IC. When mounting it in the wrong direction onto the PCB (printed-circuit-board), it might emit smoke or ignite.
2. Pay attention in the PCB (printed-circuit-board) pattern layout in order to prevent damage due to short circuit between pins. In addition, refer to the Pin Description for the pin configuration.
3. Perform visual inspection on the PCB before applying power, otherwise damage might happen due to problems such as solder-bridge between the pins of the semiconductor device. Also, perform full technical verification on the assembly quality, because the same damage possibly can happen due to conductive substances, such as solder ball, that adhere to the IC during transportation.
4. Take notice in the use of this product that it might be damaged or occasionally emit smoke when an abnormal state occurs such as output pin-VCC short (Power supply fault), output pin-GND short (Ground fault), or output-to-output-pin short (load short). Safety measures such as installation of fuses are recommended because the extent of the above-mentioned damage and smoke emission will depend on the current capability of the power supply.
5. The protection circuit is for maintaining safety against abnormal operation. Therefore, the protection circuit should not work during normal operation.
Especially for the thermal protection circuit, if the area of safe operation or the absolute maximum rating is momentarily exceeded due to output pin to VCC short (Power supply fault), or output pin to GND short (Ground fault), the IC might be damaged before the thermal protection circuit could operate.
6. Unless specified in the product specifications, make sure that negative voltage or excessive voltage are not applied to the pins because the device might be damaged, which could happen due to negative voltage or excessive voltage generated during the ON and OFF timing when the inductive load of a motor coil or actuator coils of optical pick-up is being driven.
7. The product which has specified ASO (Area of Safe Operation) should be operated in ASO.
8. Verify the risks which might be caused by the malfunctions of external components.

Request for your special attention and precautions in using the technical information and semiconductors described in this book

- (1) If any of the products or technical information described in this book is to be exported or provided to non-residents, the laws and regulations of the exporting country, especially, those with regard to security export control, must be observed.
- (2) The technical information described in this book is intended only to show the main characteristics and application circuit examples of the products. No license is granted in and to any intellectual property right or other right owned by Panasonic Corporation, Nuvoton Technology Corporation Japan or any other company. Therefore, no responsibility is assumed by our company as to the infringement upon any such right owned by any other company which may arise as a result of the use of technical information de-scribed in this book.
- (3) The products described in this book are intended to be used for general applications (such as office equipment, communications equipment, measuring instruments and household appliances), or for specific applications as expressly stated in this book.
Please consult with our sales staff in advance for information on the following applications, moreover please exchange documents separately on terms of use etc.: Special applications (such as for in-vehicle equipment, airplanes, aerospace, automotive equipment, traffic signaling equipment, combustion equipment, medical equipment and safety devices) in which exceptional quality and reliability are required, or if the failure or malfunction of the products may directly jeopardize life or harm the human body.
Unless exchanging documents on terms of use etc. in advance, it is to be understood that our company shall not be held responsible for any damage incurred as a result of or in connection with your using the products described in this book for any special application.
- (4) The products and product specifications described in this book are subject to change without notice for modification and/or improvement. At the final stage of your design, purchasing, or use of the products, therefore, ask for the most up-to-date Product Standards in advance to make sure that the latest specifications satisfy your requirements.
- (5) When designing your equipment, comply with the range of absolute maximum rating and the guaranteed operating conditions (operating power supply voltage and operating environment etc.). Especially, please be careful not to exceed the range of absolute maximum rating on the transient state, such as power-on, power-off and mode-switching. Otherwise, we will not be liable for any defect which may arise later in your equipment.
Even when the products are used within the guaranteed values, take into the consideration of incidence of break down and failure mode, possible to occur to semiconductor products. Measures on the systems such as redundant design, arresting the spread of fire or preventing glitch are recommended in order to prevent physical injury, fire, social damages, for example, by using the products.
- (6) Comply with the instructions for use in order to prevent breakdown and characteristics change due to external factors (ESD, EOS, thermal stress and mechanical stress) at the time of handling, mounting or at customer's process. We do not guarantee quality for disassembled products or the product re-mounted after removing from the mounting board.
When using products for which damp-proof packing is required, satisfy the conditions, such as shelf life and the elapsed time since first opening the packages.
- (7) When reselling products described in this book to other companies without our permission and receiving any claim of request from the resale destination, please understand that customers will bear the burden.
- (8) This book may be not reprinted or reproduced whether wholly or partially, without the prior written permission of our company.