

REV	DATE	REVISIONS	DATE	BY
00	1/24/08	REVISION	1/24/08	BMI/VJM
G		REVISED PER ECO-08-001327		

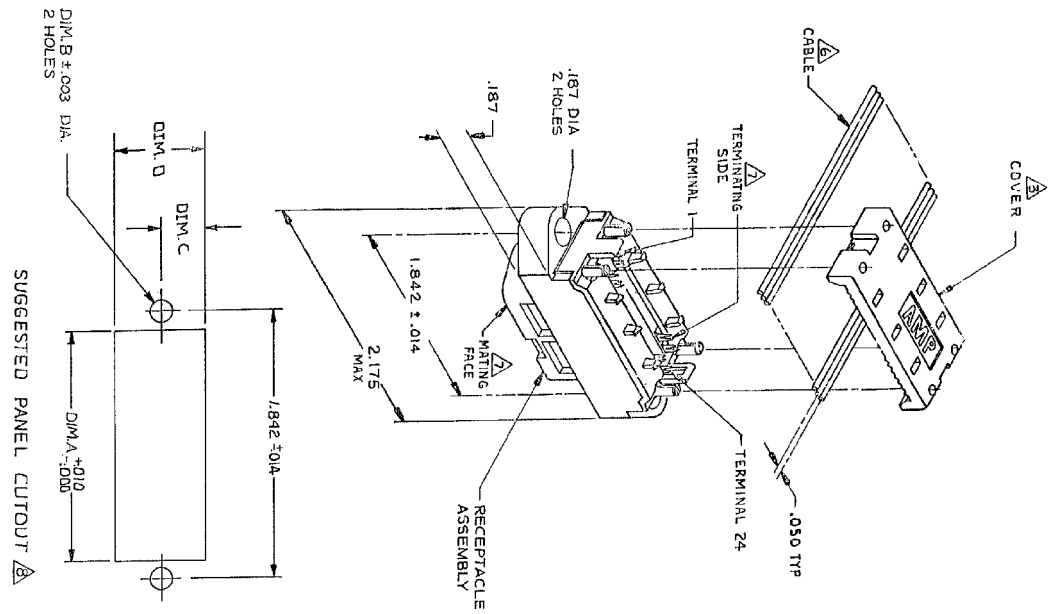

1. THE CONTACT SURFACES OF THE TERMINALS ARE COATED WITH LUBRICANT.

MATERIAL:  
 HOUSING & COVER - THERMOPLASTIC, BLACK.  
 TERMINALS - PHOS BRONZE PLATED WITH EITHER .000050 MINIMUM GOLD PLATE OR GOLD FLASH OVER PALLADIUM NICKEL PLATE. .000050 MIN TOTAL ON MATING SURFACE. GOLD FLASH PLATED ON TERMINATING SIDE. .000050 MINIMUM NICKEL UNDERPLATE OVER ENTIRE TERMINAL.

2. COVER SHOWN LOOSE BUT SHIPPED ASSEMBLED.
3. WIRE RANGE: 26 AWG SOLID THRU 30 AWG SOLID AND 28 AWG STRANDED RIBBON CABLE.
4. ALL DIMENSIONS SHOWN ARE FOR REFERENCE ONLY UNLESS OTHERWISE SPECIFIED.
5. FLAT CABLE SHALL BE FURNISHED BY CUSTOMER.
6. MATING FACE CONSISTS OF TWO ROWS OF TERMINALS ON .085 CENTERS. TERMINATING SIDE CONSISTS OF TERMINALS ON .100 CENTERS FOR AN EFFECTIVE .050 TERMINATION.
7. PANEL THICKNESS RANGE: .125 MAX FRONT PANEL MOUNTING - .062 MAX REAR PANEL MOUNTING
8. FOR MORE INFORMATION REFER TO AMP PRODUCT SPECIFICATION 108-6076 & APPLICATION SPEC 114-6030.

DIM	VALUE	DESCRIPTION
.620	.310	REAR PANEL MOUNTING
.640	.320	FRONT PANEL MOUNTING
DIM D	DIM C	DIM B
		DIM A

THIS DRAWING IS A CONTROLLED DOCUMENT.

DATE: 1/24/08  
 BY: W. MILLIKENS  
 TITLE: RECEPTACLE ASSEMBLY, 24 POSITION PANEL MOUNTING, LOW PROFILE, CHAMP LATCH

APPROVED: [Signature]  
 TITLE: [Title]

SCALE: 2:1 SHEET 1 OF 1 REV G