

MAXIM

MAX120 Evaluation Kit

EV Kit General Description

The MAX120 evaluation kit (EV kit) provides a proven design, and a fully assembled PC board for fast and easy evaluation of the MAX120 at sample rates up to 500k samples per second (ksps). The kit includes a MAX120 and 6 other integrated circuits mounted on a 6" x 7" printed circuit board. It can be easily configured for any of the 5 operating modes described in the MAX120/MAX122 data sheet. And, prototyping space is provided for additional circuits. The board operates from $\pm 15V$ supplies.

The MAX120 EV kit can be used to evaluate the MAX122. To order a free MAX122 sample from Maxim, call toll-free 1-800-998-8800, FAX 408-737-7194, or return one of the sample request cards found inside every *A/D Converter Design Guide*.

Component List

DESIGNATION	QTY	DESCRIPTION
C1	0	User-supplied capacitor
C2, C3, C4, C6, C8, C13, C14, C15, C16	9	0.1 μ F capacitors
C5	1	22 μ F, radial, low-ESR electrolytic capacitor
C7, C9, C11, C12, C18	5	15 μ F, radial tantalum capacitors
C10	1	100pF capacitor
C17	0	User-supplied capacitor
J1-J6	6	BNC connectors
J7	1	20-pin IDC header
JU1, JU2, JU3, JU4	4	3-pin jumper headers
JU5	1	2-pin jumper header
None	5	Shunts (jumpers)
R1, R3, R5, R7	4	51 Ω 5% resistors
R2, R4, R6	3	300 Ω 5% resistors
R8	1	10k Ω 5% resistor
R9	0	User-supplied resistor
R10	1	100 Ω 5% resistor
R11-R22	12	620 Ω 5% resistors
LED1-LED12	12	High-brightness LEDs
U1	1	78M05 5V regulator
U2	0	User-supplied op amp
U3	1	MAX120 12-bit ADC
U4	1	74HCT00 quad NAND gate
U5, U6	2	74HCT574 octal latches
U7A	1	8.00MHz oscillator
U7B	1	5.00MHz oscillator
None	1	14-pin, 300mil socket
None	1	24-pin, 300mil socket
None	1	3-terminal power connector
None	4	Rubber feet
None	1	6.00" x 7.00" printed circuit board
None	1	MAX120 EV kit manual
None	1	MAX120/MAX122 data sheet

Features

- ◆ Proven 500ksps, 12-Bit ADC Layout and Circuit Design
- ◆ Fully Assembled PC Board
- ◆ LED Displays for Output Monitoring
- ◆ 5 Selectable Operating Modes
- ◆ 4 Square Inches of Prototyping Area

Ordering Information

PART	TEMP. RANGE	BOARD TYPE
MAX120EVKIT-DIP	0°C to +70°C	Plastic DIP – Through Hole

MAX120 EV Kit

MAX120 Evaluation Kit

Quick Reference

Verify that the board is functioning properly by operating the MAX120 in the continuous-conversion mode. Configure the board for continuous conversions by setting the jumpers as shown in Table 1, and then apply power. The setup given causes the MAX120 to continuously convert. Connect a low-frequency AC signal or variable DC source ($\pm 5V$ max) to the analog input J4, and verify that the LED display tracks the input.

After setting the jumpers, connect a $\pm 15V$ supply with 500mA capability to the power connector. When the power is turned on, the LEDs indicate the MAX120's output code. Should the LEDs fail to respond, turn off the power and verify the jumper settings. Be sure to turn off the power before changing the jumpers.

When operating the evaluation board with the 333ksps MAX122, the 8MHz crystal oscillator must be removed from its socket and replaced with the 5MHz oscillator (included).

Table 1. Board Verification (Continuous-Conversion Mode)

JUMPER	SHUNT POSITION	DESCRIPTION
JU1	2 & 3	Set for on-board oscillator
JU2	2 & 3	MAX120 MODE pin grounded. MAX120 operates with a busy output, continuous conversions.
JU3	2 & 3	Output latch triggered by MAX120 busy output
JU4	1 & 2	MAX120 input driven directly from J4, V_{IN} BNC connector
JU5	1 & 2	Enables the LED display

Important: Cycle power to board after jumper sections are complete, otherwise conversions will not start.

BNC CONNECTOR	DESCRIPTION	CONNECTION
J1	MAX120 Read Input – \overline{RD}	Open
J2	MAX120 Chip Select – \overline{CS}	Open
J3	MAX120 Conversion Start – CONVST	Open
J4	MAX120 Analog Input – AIN	$\pm 5V$ max
J5	MAX120 Reference Voltage – VREF	Open
J6	External Clock Input – CLKIN	Open

General Description

The MAX120 EV kit can operate the MAX120 or MAX122 in any of the 5 operating modes described in the data sheet. Refer to the MAX120/MAX122 data sheet for descriptions of these operating modes and their timing diagrams, then use Table 2 to configure the MAX120 EV kit to simulate the conditions. Note that continuous-conversion mode requires only one signal generator (for the

analog input), while other modes require one or more timing signal generators.

Movable jumpers on the PC board allow the user to easily configure the EV kit for the various MAX120 modes. Table 2 describes the function of each jumper.

Table 2. Jumper Functions

JUMPER	FUNCTION	SHUNT	DESCRIPTION
JU1	Clock Select	1 & 2	User provides system clock on J6 (external clock).
		2 & 3	Clock signal provided by on-board oscillator.
JU2	MAX120 MODE Pin	Open	MAX120 MODE pin open
		1 & 2	MAX120 MODE pin to V_{DD}
		2 & 3	MAX120 MODE pin to GND
JU3	Latch Trigger Selection	1 & 2	Latch triggered by MAX120 interrupt output
		2 & 3	Latch triggered by MAX120 busy output
JU4	Input Selection	1 & 2	MAX120 input connected directly to J4, V_{IN}
JU5	LED Enable	Open	LEDs disabled
		1 & 2	LEDs display the output of the 74HCT574 latches.

Power for the board attaches to the three-pin, screw-terminal power connector near the bottom. The board requires $\pm 15V$ power supplies capable of 500mA. Be sure to observe the polarity markings printed on the board. A 78M05 regulator provides the +5V supply for the MAX120 and digital circuitry.

The MAX120's analog input should be driven by a low-impedance signal source, to avoid input noise. To facilitate evaluation of different op amps with the MAX120, the printed-circuit layout has a location (U2) reserved for a user-supplied op amp. The type used, if any, will depend on system requirements, but a high-speed op amp such as the AD711 works well in most applications. Note that a location has also been provided at the MAX120 input for a capacitor (C17), which may be added when driven by a source with high AC impedance. The value of C17 should be in the $0.01\mu F$ to $0.1\mu F$ range, provided the input source will drive the capacitive load.

Driving the LEDs adds about 1/2LSB noise when operating the MAX120 at high clock rates. It is advisable to disable the LEDs while performing accuracy or noise-level measurements.

MAX120 Evaluation Kit

MAX120 EV Kit

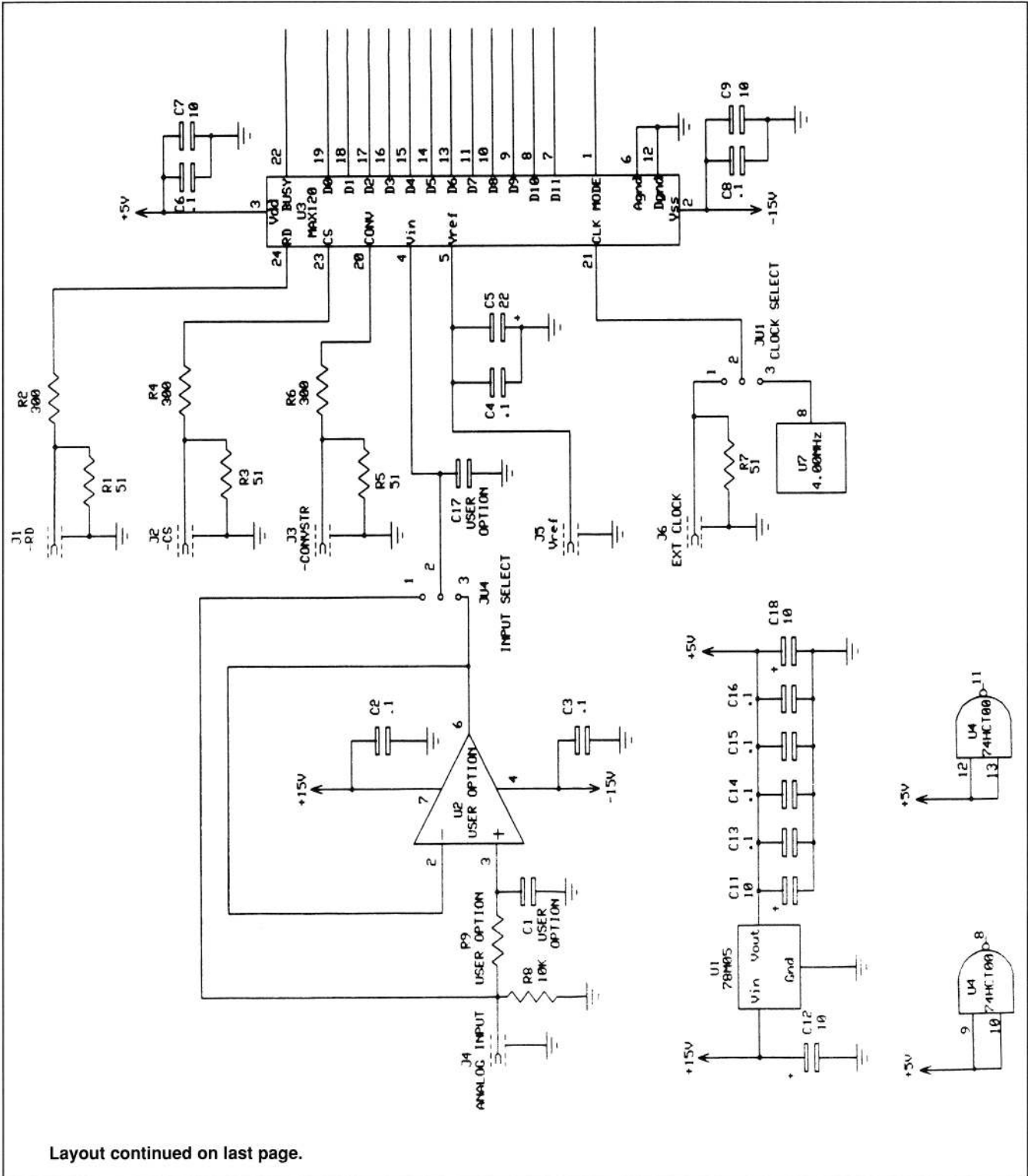

Layout continued on last page.

Figure 1. MAX120 Evaluation Kit Schematic

