

PRODUCT NO.
10160298-111XXXXLF

Printing with Data Matrix code

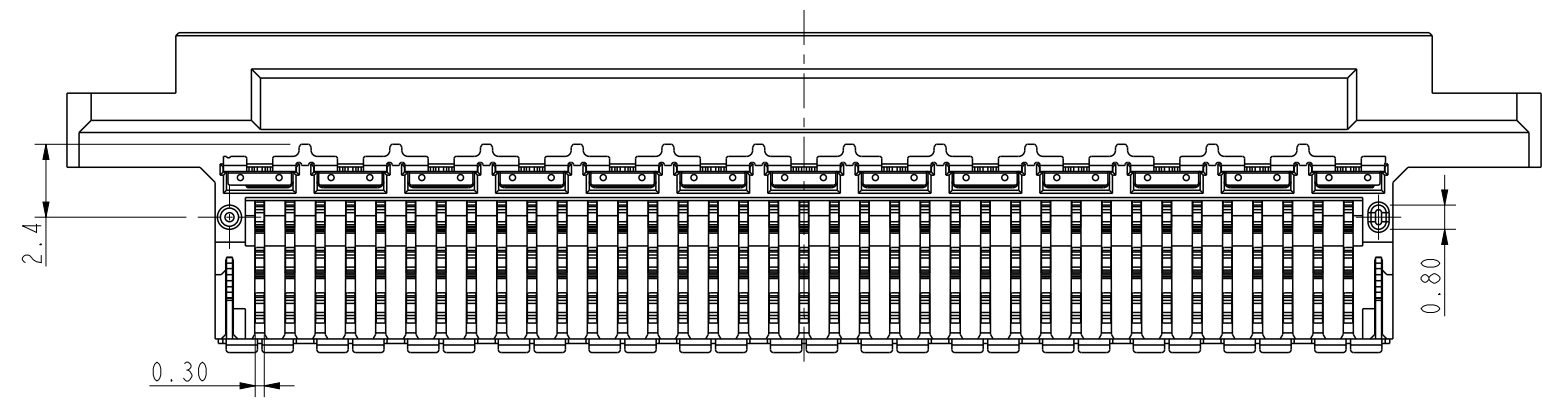
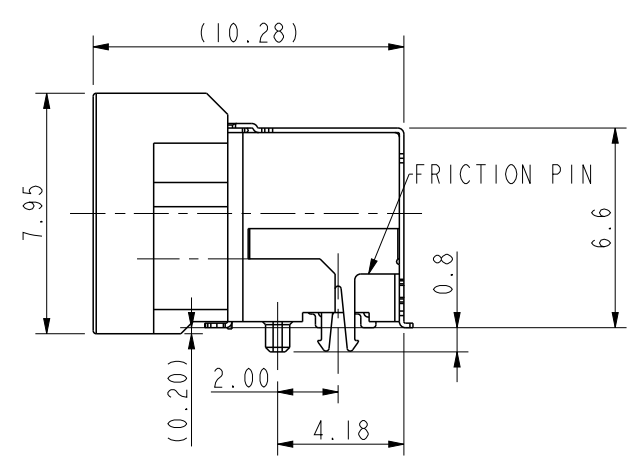
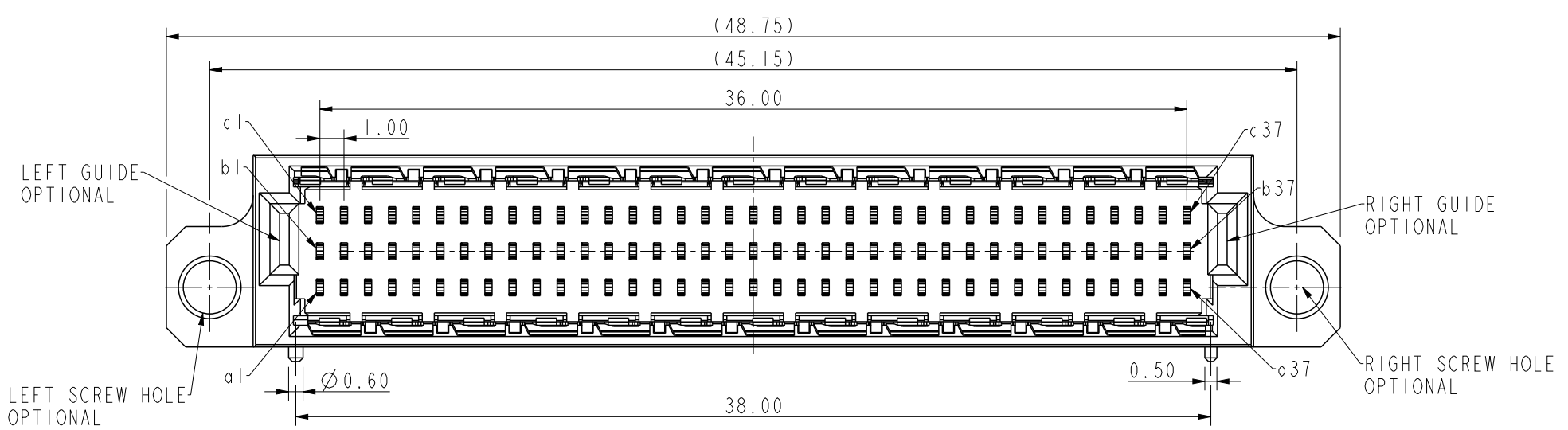
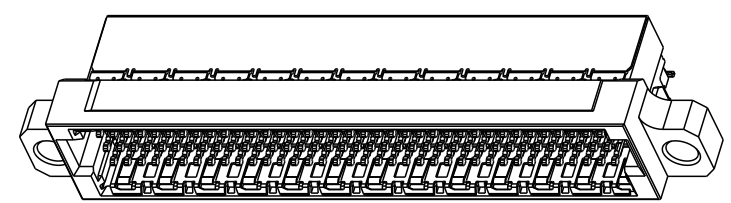
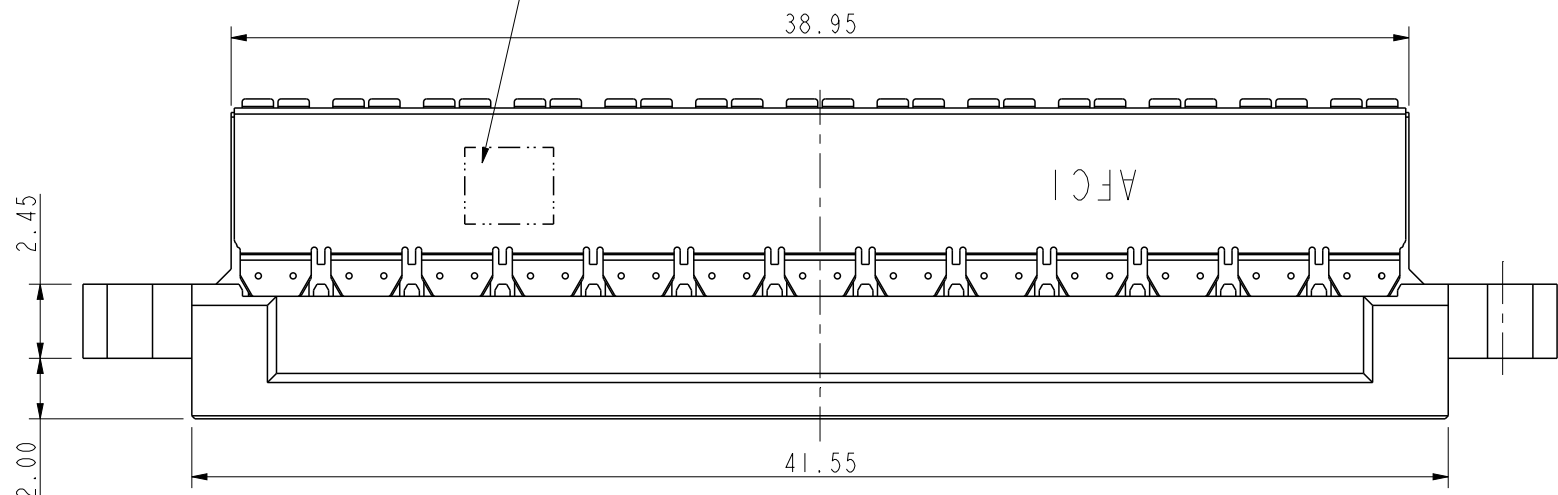

- NOTES:
- MATERIAL:
 - HOUSING: THERMOPLASTIC
 - TERMINAL AND SHIELD: COPPER ALLOY
 - PLATING: 1-3µm NI UNDER PLATING;
 - CONTACT AREA: ACCORDING TO PART NUMBER;
 - SOLDER TAIL: ACCORDING TO PART NUMBER.
 - COPLANARITY AREA OF TERMINATION 0.10MM MAX
 - THIS HOUSING WILL WITHSTAND EXPOSURE TO 260°C PEAK TEMPERATURE FOR 20 SECONDS IN A IR REFLOW SOLDERING APPLICATION

Amphenol
FCi

© 2016 AFCi

spec ref	*	dr	Li-Qing Lei	2020/09/23	projection	mm	size	A3	scale	4:1											
tolerance std	TOLERANCES UNLESS OTHERWISE SPECIFIED	eng	Li-Qing Lei	2020/12/14			ecn no	-	rel level	Released											
surface	<table border="1"> <tr> <td>linear</td> <td>0.X</td> <td>±0.25</td> </tr> <tr> <td></td> <td>0.XX</td> <td>±0.15</td> </tr> <tr> <td></td> <td>0.XXX</td> <td>±0.10</td> </tr> <tr> <td>ASME Y14.5</td> <td>angular</td> <td>0°</td> <td>±2°</td> </tr> </table>	linear	0.X	±0.25				0.XX		±0.15		0.XXX	±0.10	ASME Y14.5	angular	0°	±2°	appr	Tim Yao	2020/12/14	product family
linear	0.X	±0.25																			
	0.XX	±0.15																			
	0.XXX	±0.10																			
ASME Y14.5	angular	0°	±2°																		
		cat. no.				Product - Customer Drw	sheet 1 of 2	dwg no	10160298	rev	A										

10160298-111XX11LF

(44.15)

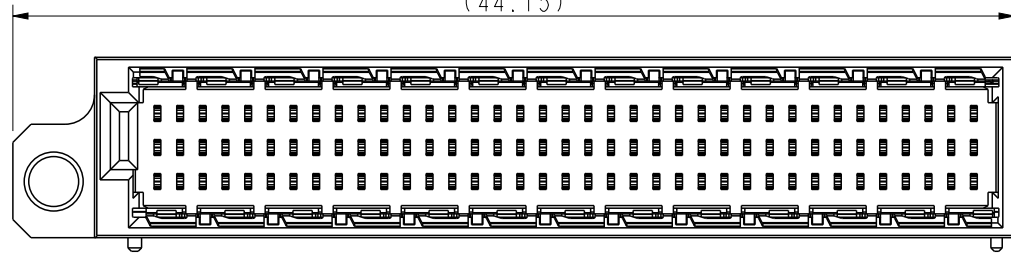

10160298-111XX00LF

39.55

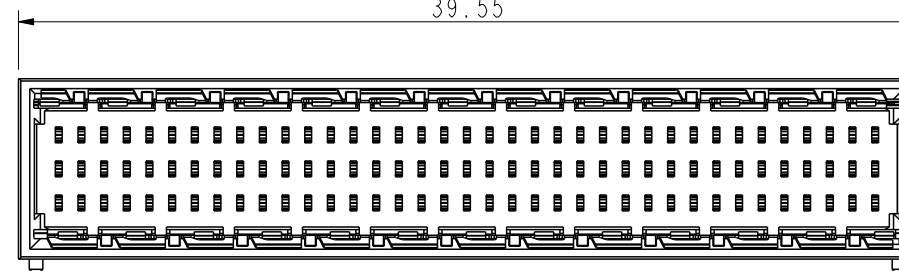

10160298-111XX02LF

(40.55)

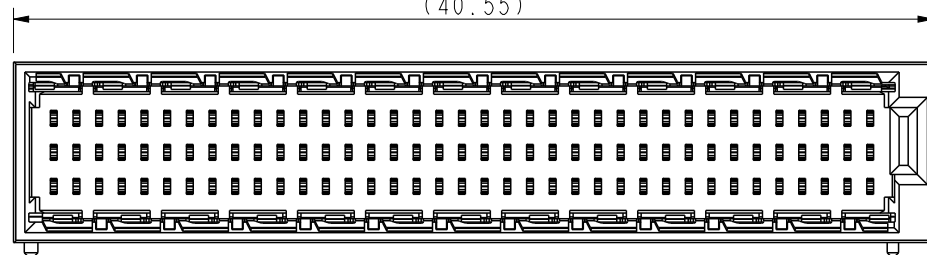

PART NUMBER DESCRIPTION

PIN NUMBER	10160298-111XXXXLF	LEAD FREE
PLATING OPTION:		GUIDE OPTION
CONTACT AREA AND SOLDER TAIL;		0: WITHOUT GUIDE;
1. 8u" GXT OR GOLD ON CONTACT AREA;		1: WITH LEFT GUIDE;
80-160u" TIN OR GOLD FLASH ON SOLDER TAIL;		2: WITH RIGHT GUIDE;
		3: WITH BOTH GUIDES.
FUNCTION OPTION		SCREW HOLE OPTION
0. NOT ONE TIME;		0: WITHOUT SCREW HOLE;
1. ONLY ONE TIME.		1: WITH LEFT SCREW HOLE;
		2: WITH RIGHT SCREW HOLE;
		3: WITH BOTH SCREW HOLES.

PCB LAYOUT PROPOSAL
TOLERANCE RECOMMENDED ±0.05

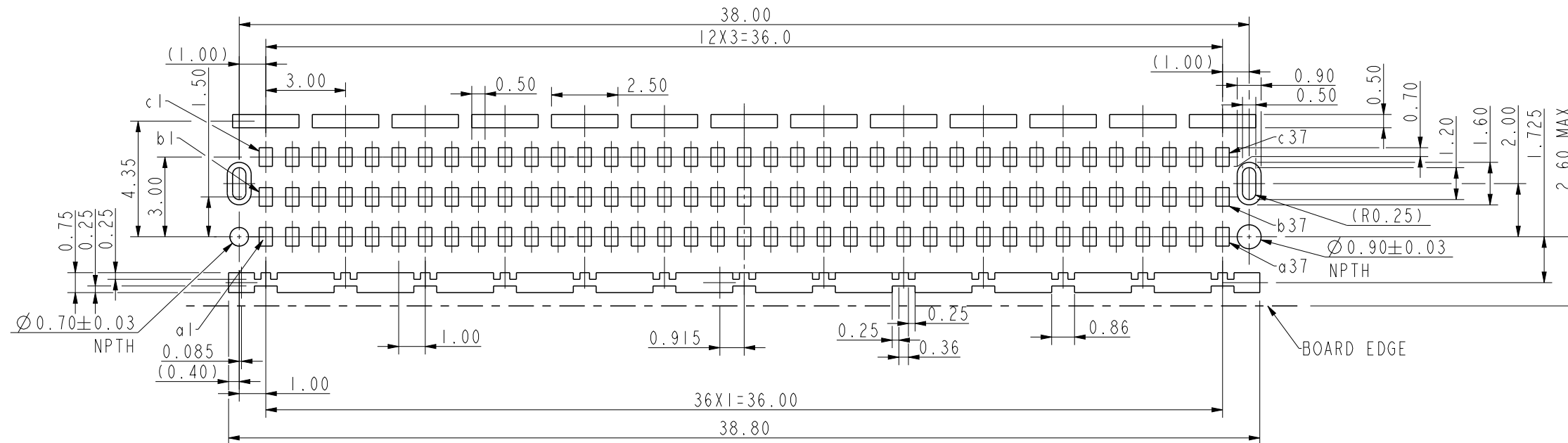

spec ref	*	dr	Li-Qing Lei	2020/09/23	projection	mm	size	A3	scale	5:1	
tolerance std	TOLERANCES UNLESS OTHERWISE SPECIFIED	eng	Li-Qing Lei	2020/12/14			ecn no	-	rel level	Released	
surface	linear	chr	-	appr							Tim Yao
ASME Y14.5	angular	0°	±2°	Amphenol FCI		cat. no.	Product - Customer Drw	sheet 2 of 2			