

PART NUMBER	REVISION	DESCRIPTION	FEED TYPE
2150436-2	D	FINE CRIMP HEIGHT ADJUST	PNEUMATIC
7-2150436-2	D	PNEUMATIC AND CRIMP TOOLING KIT	PNEUMATIC
7-2150436-7	C	CRIMP TOOLING KIT	-

ATLANTIC VERSION TERMINATOR INTERFACE ADAPTER

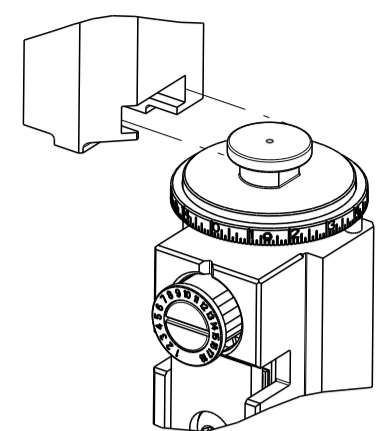

APPLICATOR DATA		
CRIMP	SIZE	TYPE
WIRE	2.79 mm [.110]	F
INSUL	3.56 mm [.140]	F
APPL INSTRUCTIONS 408-35043		

TERMINAL DATA: TE TERMINAL TE CRIMP SPECIFICATION			
TERMINAL NAME: RECEPTACLE CLUSTER PIN .090 DIA			
WIRE STRIP LENGTH 4.71-5.47 mm [.185-.215 IN]	INSULATION DIAMETER RANGE Ø1.50-2.62 mm [.059-.103 IN]		
TERMINAL APPLICATION SPECIFICATION 114-2019			
TERMINALS APPLIED			
TE TERMINAL 62131-3 2178453-2	TE TERMINAL 62131-5 284633-1	TE TERMINAL 62131-6	TE TERMINAL 2178453-1

WIRE SIZE	CRIMP HEIGHT mm [INCH]	CRIMP HEIGHT REFERENCE SETTING
16 AWG OR 1.30mm ²	1.65 +/- 0.05 [.065 +/- .002]	5.2
18 AWG OR 0.80mm ²	1.50 +/- 0.05 [.059 +/- .002]	6.9

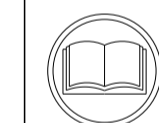

- 1 RECOMMENDED SPARE PARTS
- 2 REFER TO SUPPLIED INSTRUCTION SHEET FOR CLEANING, LUBRICATION AND STORAGE OF APPLICATOR.
- 3 APPLY PART NUMBER 2-23419-6 LOCTITE TO THREADS OF ITEM 242.
- 4 CRIMP HEIGHT REFERENCE SETTING WAS THE SETTING USED WHEN THE APPLICATOR WAS QUALIFIED AT THE FACTORY. ADJUSTMENT MAY BE NECESSARY WHEN RUNNING APPLICATOR IN THE FIELD.
- 5 TERMINAL PITCH NOT COMPATIBLE WITH MECHANICAL FEED. POSITION FEED FINGER TO FEED OFF RECEPTACLE.
- 6. UNLESS SPECIFIED OTHERWISE TORQUE VALUES SHALL BE USED PER DOCUMENT, 101-35000.

***WARNING**
ON INSTALLATION, SET WIRE DISC TO CRIMP HEIGHT REFERENCE SETTING FOR LARGEST WIRE SIZE. CRIMP HEIGHT REFERENCE SETTINGS GREATER THAN THE VALUE SHOWN MAY CAUSE DAMAGE TO THE CRIMP TOOLING, REFER TO THE INSTRUCTION SHEET FOR PROPER SETUP AND ADJUSTMENTS.

LOC	DIST	REVISIONS					
A	66	P	LTN	DESCRIPTION	DATE	OWN	APVD
		A2		ECR-20-006613	08MAY2020	FZ	RK
		B		ECR-20-013765	27SEP2020	FZ	TE
		C		ECR-20-015236	26OCT2020	JWC	GB
		D		ECR-21-006572	28JUN2021	JWC	TE

-	1	1	2119641-1	FEED CAM, AIR FEED	248	
-	1	1	2119082-8	CAM, SNAIL, INSULATION ADJUSTMENT	244	
-	1	1	2079764-1	WASHER, WAVE SPRING, CREST-TO-CREST	243	
-	1	1	2119083-1	RETAINER, INSULATION DIAL	242	
-	1	1	2844940-3	AIR FEED MODULE	238	
-	1	1	1-18028-0	WASHER, FLAT, REG M8	192	
-	REF	REF	994970-2	COUNTER, MAGNETIC	164	
-	1	1	455888-7	SPACER, CRIMPER	82	
-	1	1	804939-2	TOOL, SIZING	76	
-	1	1	1803607-4	DOCUMENTATION PACKAGE	71	
-	2	2	2-18032-2	SCR, SET, FLT PNT, M3 X 10.0	70	
-	1	1	2119740-1	TAG, IDENTIFICATION	67	
-	2	2	2168078-1	SCREW, DRIVE, RH, RoHS, 2 x .188	66	
-	2	2	2168400-5	SHCS, LOW HEAD, RoHS, M4 X 20	64	
-	1	1	2168083-2	SCR, SKT HD CAP, RoHS, M4 X 8.0	60	
-	1	1	5-18022-5	SCR, HEX HD CAP, M4 X 6.0	59	
-	3	3	2168400-4	SHCS, LOW HEAD, RoHS, M4 X 8	57	
-	2	2	2168083-2	SCR, SKT HD CAP, RoHS, M4 X 8.0	56	
-	2	2	5018030-1	NUT, HEX, REG, RoHS, M3	54	
-	2	2	986965-8	NUT, LOCK, HEX, TORQUE (M4)	53	
-	1	1	2063961-9	FEED FINGER	51	
-	1	1	18023-9	SCR, SKT HD CAP M4 X 6.0	49	
-	1	1	2119655-5	APPLICATOR BASIC ASSEMBLY, EF	46	
-	1	1	1803517-1	RAM ASSEMBLY, EF ATLANTIC	44	
-	1	1	1803602-1	SCR, BHSC, RoHS (M8 X 25)	41	
-	7	7	1-18028-2	WASHER, FLAT, REG M4	33	
-	2	2	2168083-9	SCR, SKT HD CAP, RoHS, M4 X 20	31	
-	2	2	2168083-2	SCR, SKT HD CAP, RoHS, M4 X 8.0	29	
-	1	1	240639-1	STRIPPER (MACHINING)	27	
-	2	2	1-2168083-5	SCR, SKT HD CAP, RoHS, M4 X 30	25	
-	1	1	1752371-5	PLATE, STRIP GUIDE	24	
-	1	1	240825-1	PLATE, STRIP HOLD DOWN	23	
-	2	2	2-22281-3	SPRING, COMPRESSION	22	
-	1	1	1803292-4	DRAG	20	
-	2	2	1901259-5	GUIDE, LOWER STRIP	18	
-	4	4	1-2079383-1	SCR, BHSC, RoHS (M6 X 12)	17	
-	1	1	6-240641-4	SPACER	16	
-	1	1	240644-1	PLATE, REAR SHEAR	11	
-	-	-	-	-	10	
-	1	1	690482-5	PLATE, FRONT SHEAR	9	
-	1	2	1	4-1803001-6	ANVIL, COMBINATION, END FEED	8
-	1	1	1	2217206-7	BLADE, SLUG	7
-	-	-	-	-	6	
-	1	1	1	238011-8	BLOCK, CRIMPER SPACER	4
-	1	2	1	2-2119582-4	CRIMPER, INSULATION F PREMIUM	3
-	1	1	1	1-455888-8	SPACER, CRIMPER	2
-	1	2	1	456408-8	CRIMPER, WIRE PREMIUM	1
-	77	72	2	PART NO	DESCRIPTION	ITEM NO

ATLANTIC VERSION
Shown on sheets 1 of 4 & 2 of 4
(Pacific version shown on sheets 3 of 4 & 4 of 4)

DIMENSIONS:		TOLERANCES UNLESS OTHERWISE SPECIFIED:		MATERIAL:		FINISH:		WEIGHT:		SCALE:		SHEET:		REV:				
mm	0 PLC ±	1 PLC ±	2 PLC ±	3 PLC ±	4 PLC ±	ANGLES	FINISH			Customer Accessible Production Drawing	SCALE	1:1	SHEET	1	OF	4	REV	D

LOC	DIST	REVISIONS			
P	LTN	DESCRIPTION	DATE	DMN	APVD
A	66	SEE SHEET 1	-	-	-

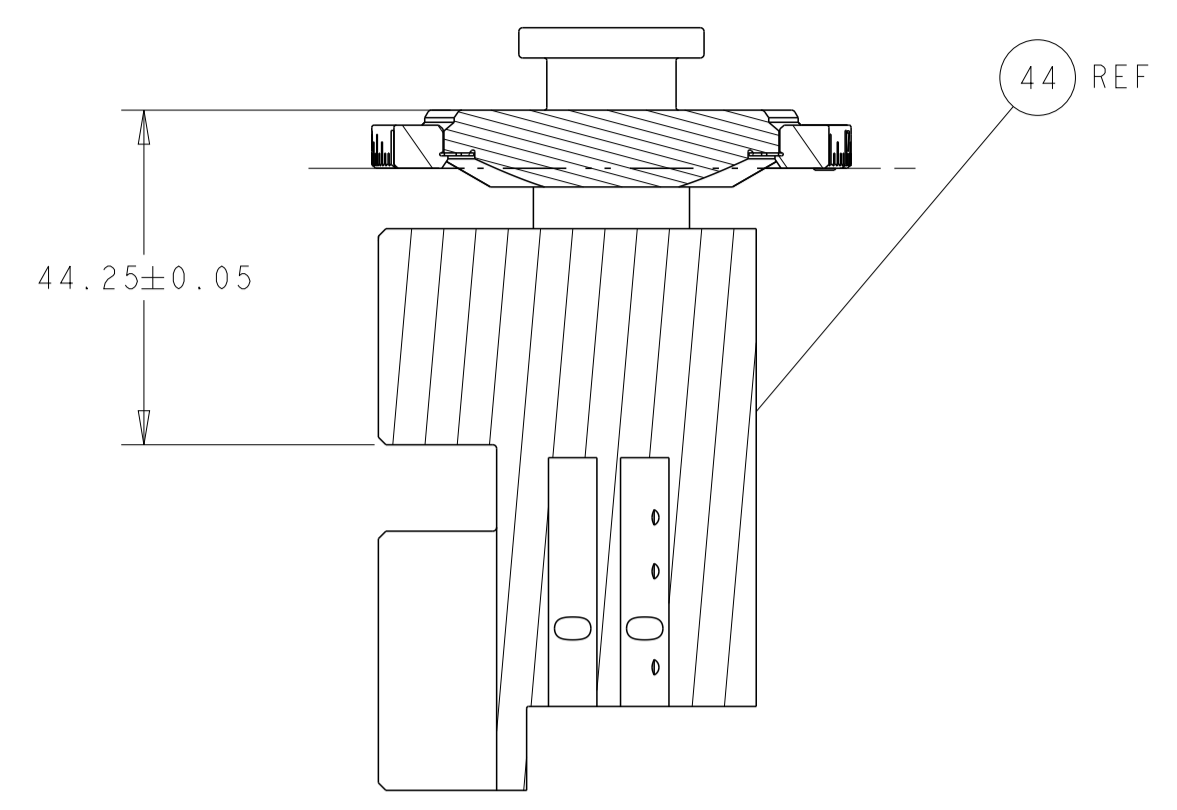

RAM SET-UP

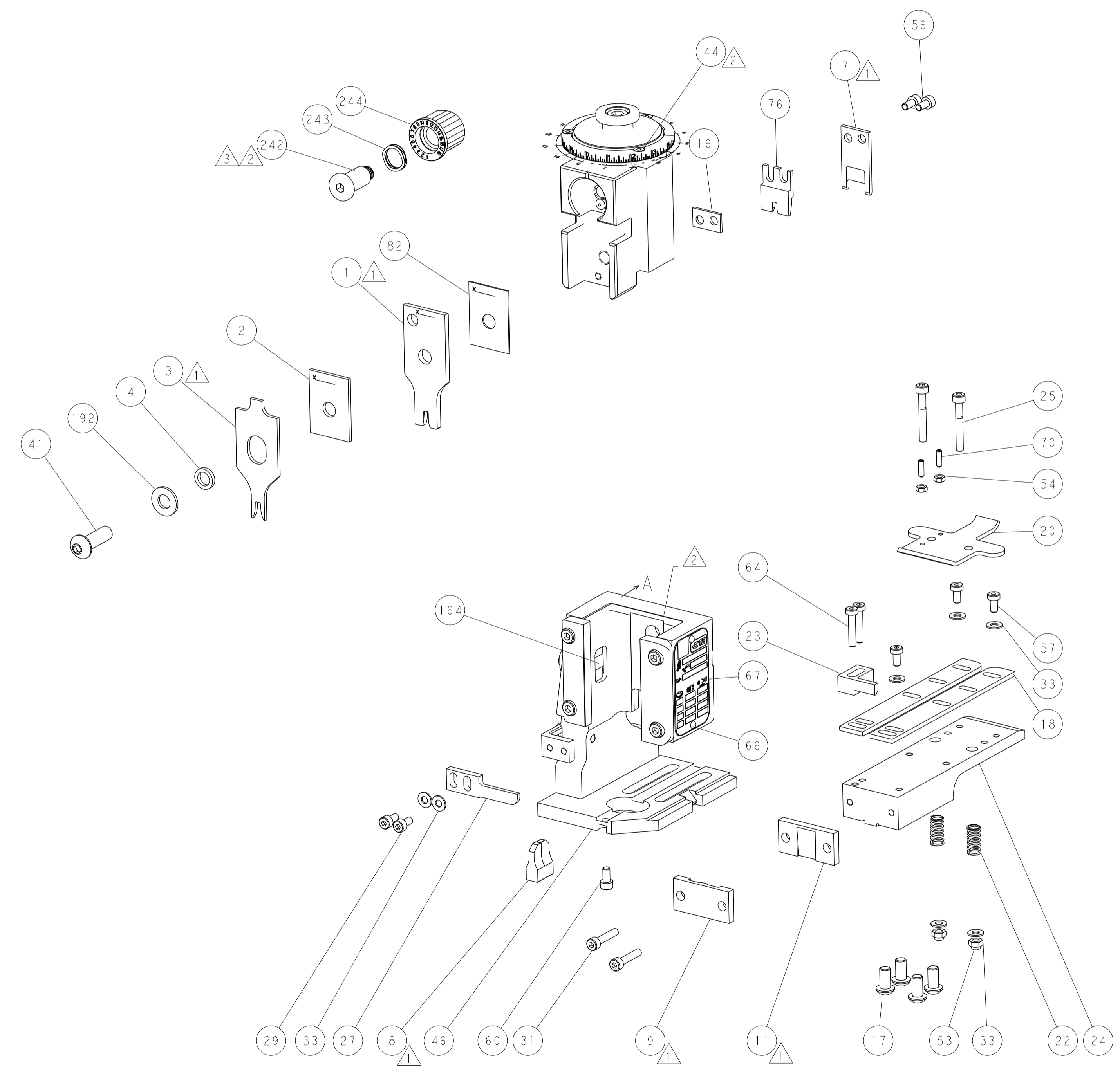

FEED TYPE

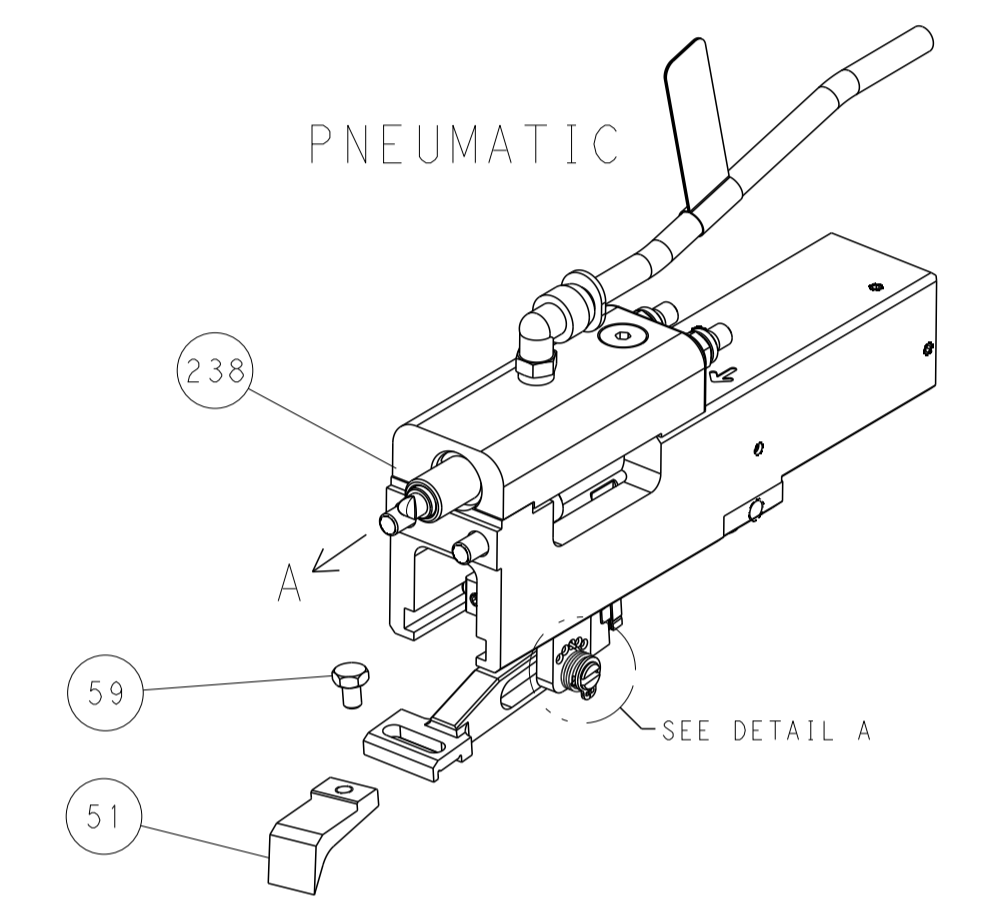

FEED SPRING SETTING POSITION

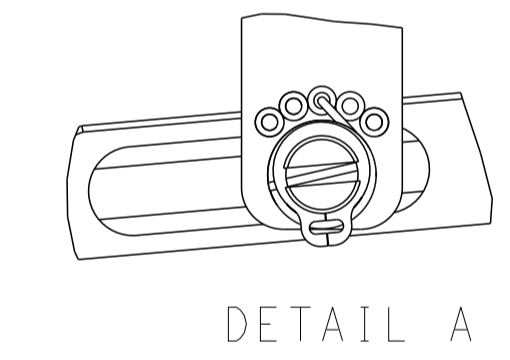

CAM POSITION

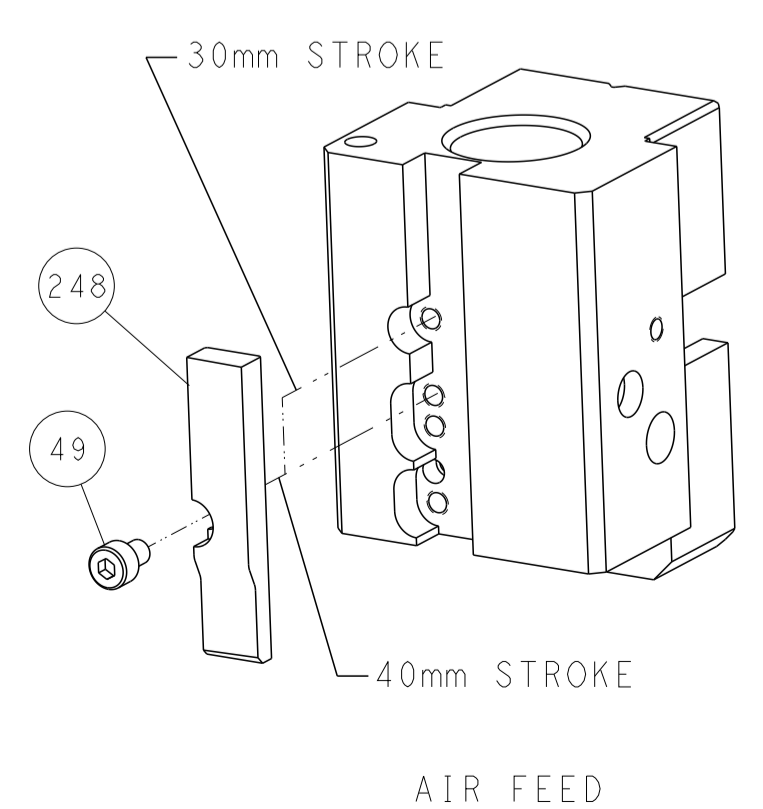

ATLANTIC VERSION
 Shown on sheets 1 of 4 & 2 of 4
 (Pacific version shown on sheets 3 of 4 & 4 of 4)

<small>THIS DRAWING IS UNPUBLISHED. RELEASED FOR PUBLICATION BY TYCO ELECTRONICS CORPORATION. ALL RIGHTS RESERVED.</small>		DWN: Y. YIN 29APR2014 CHK: G. BAILEY 29APR2014 APVD: J. GUO 29APR2014	NAME: Ocean End Feed Applicator SIZE: A1 CAGE CODE: 00779 DRAWING NO: 2150436	TE Connectivity Harrisburg, PA 17105-3608
DIMENSIONS: mm TOLERANCES UNLESS OTHERWISE SPECIFIED: 0 PLC ± 1 PLC ± 2 PLC ± 3 PLC ± 4 PLC ± ANGLES ± FINISH ±	TOLERANCES UNLESS OTHERWISE SPECIFIED: 0 PLC ± 1 PLC ± 2 PLC ± 3 PLC ± 4 PLC ± ANGLES ± FINISH ±	PRODUCT SPEC APPLICATION SPEC WEIGHT SCALE: 1:1	SHEET 2 OF 4 REV D	RESTRICTED TO

8	7	6	5	4	3	2	1
THIS DRAWING IS UNPUBLISHED.		RELEASED FOR PUBLICATION		20			
COPYRIGHT 20 BY TYCO ELECTRONICS CORPORATION. ALL RIGHTS RESERVED.							
PART NUMBER	REVISION	DESCRIPTION	FEED TYPE				
2-2150436-2	D	FINE CRIMP HEIGHT ADJUST	PNEUMATIC				
7-2150436-7	C	CRIMP TOOLING KIT	-				

PACIFIC VERSION TERMINATOR
INTERFACE ADAPTER

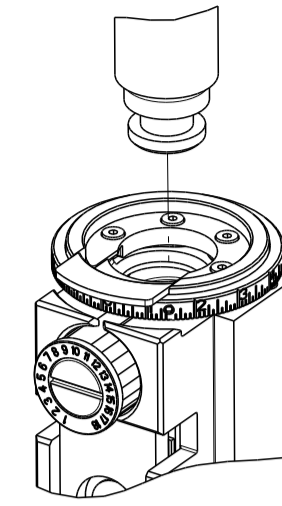

APPLICATOR DATA		
CRIMP	SIZE	TYPE
WIRE	2.79 mm (.110)	F
INSUL	3.56 mm (.140)	F
APPL INSTRUCTIONS 408-35043		

TERMINAL DATA: TE TERMINAL		TE CRIMP SPECIFICATION	
TERMINAL NAME: RECEPTACLE CLUSTER PIN .090 DIA			
WIRE STRIP LENGTH 4.71-5.47 mm (.185-.215 IN)		INSULATION DIAMETER RANGE Ø1.50-2.62 mm (.059-.103 IN)	
TERMINAL APPLICATION SPECIFICATION	114-2019	-	-
TERMINALS APPLIED			
TE TERMINAL	TE TERMINAL	TE TERMINAL	TE TERMINAL
62131-3	62131-5	62131-6	2178453-1
2178453-2	284633-1		

WIRE SIZE	CRIMP HEIGHT mm [INCH]	CRIMP HEIGHT REFERENCE SETTING
16 AWG OR 1.30mm2	1.65+/-0.05 [.065+/-0.002]	5.2
18 AWG OR 0.80mm2	1.50+/-0.05 [.059+/-0.002]	6.9

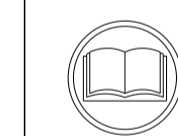

- 1 RECOMMENDED SPARE PARTS
- 2 REFER TO SUPPLIED INSTRUCTION SHEET FOR CLEANING, LUBRICATION AND STORAGE OF APPLICATOR.
- 3 APPLY PART NUMBER 2-23419-6 LOCTITE TO THREADS OF ITEM 242.
- 4 CRIMP HEIGHT REFERENCE SETTING WAS THE SETTING USED WHEN THE APPLICATOR WAS QUALIFIED AT THE FACTORY. ADJUSTMENT MAY BE NECESSARY WHEN RUNNING APPLICATOR IN THE FIELD.
- 5 TERMINAL PITCH NOT COMPATIBLE WITH MECHANICAL FEED, POSITION FEED FINGER TO FEED OFF RECEPTACLE.
- 6. UNLESS SPECIFIED OTHERWISE TORQUE VALUES SHALL BE USED PER DOCUMENT, 101-35000.

***WARNING**
ON INSTALLATION, SET WIRE DISC TO CRIMP HEIGHT REFERENCE SETTING FOR LARGEST WIRE SIZE. CRIMP HEIGHT REFERENCE SETTINGS GREATER THAN THE VALUE SHOWN MAY CAUSE DAMAGE TO THE CRIMP TOOLING, REFER TO THE INSTRUCTION SHEET FOR PROPER SETUP AND ADJUSTMENTS.

PACIFIC VERSION
Shown on sheets 3 of 4 & 4 of 4
(Atlantic version shown on sheets 1 of 4 & 2 of 4)

LOC	DIST	REVISIONS					
A	66	P	LTN	DESCRIPTION	DATE	OWN	APVD
		-		SEE SHEET 1	-	-	-

-	1	2119082-8	CAM, SNAIL, INSULATION ADJUSTMENT	244
-	1	2079764-1	WASHER, WAVE SPRING, CREST-TO-CREST	243
-	1	2119083-1	RETAINER, INSULATION DIAL	242
-	1	2844940-3	AIR FEED MODULE	238
-	1	1-18028-0	WASHER, FLAT, REG M8	192
-	4	2079383-9	SCR, BHSC, RoHS (M6 X 20)	186
-	REF	994970-2	COUNTER, MAGNETIC	164
-	1	2119641-2	FEED CAM, AIR FEED	152
-	1	2168083-8	SCR, SKT HD CAP, RoHS, M4 X 16	144
-	1	2119655-6	APPLICATOR BASIC ASSEMBLY, EF	141
-	1	1803518-1	RAM ASSEMBLY, EF PACIFIC	140
-	1	455888-7	SPACER, CRIMPER	82
-	1	804939-2	TOOL, SIZING	76
-	1	1803607-4	DOCUMENTATION PACKAGE	71
-	2	2-18032-2	SCR, SET, FLT PNT, M3 X 10.0	70
-	1	2119740-1	TAG, IDENTIFICATION	67
-	2	2168078-1	SCREW, DRIVE, RH, RoHS, 2 x .188	66
-	2	2168400-5	SHCS, LOW HEAD, RoHS, M4 X 20	64
-	1	5-18022-5	SCR, HEX HD CAP, M4 X 6.0	59
-	3	2168400-4	SHCS, LOW HEAD, RoHS, M4 X 8	57
-	2	2168083-2	SCR, SKT HD CAP, RoHS, M4 X 8.0	56
-	2	5018030-1	NUT, HEX, REG, RoHS, M3	54
-	2	986965-8	NUT, LOCK, HEX, TORQUE (M4)	53
-	1	2063961-9	FEED FINGER	51
-	1	18023-9	SCR, SKT HD CAP M4 X 6.0	49
-	1	1803602-1	SCR, BHSC, RoHS (M8 X 25)	41
-	7	1-18028-2	WASHER, FLAT, REG M4	33
-	2	2168083-9	SCR, SKT HD CAP, RoHS, M4 X 20	31
-	2	2168083-2	SCR, SKT HD CAP, RoHS, M4 X 8.0	29
-	1	240639-1	STRIPPER (MACHINING)	27
-	2	1-2168083-5	SCR, SKT HD CAP, RoHS, M4 X 30	25
-	1	1752371-5	PLATE, STRIP GUIDE	24
-	1	240825-1	PLATE, STRIP HOLD DOWN	23
-	2	2-22281-3	SPRING, COMPRESSION	22
-	1	1803292-4	DRAG	20
-	2	1901259-5	GUIDE, LOWER STRIP	18
-	1	6-240641-4	SPACER	16
-	1	240644-1	PLATE, REAR SHEAR	11
-	-	-	-	10
-	1	690482-5	PLATE, FRONT SHEAR	9
1	1	4-1803001-6	ANVIL, COMBINATION, END FEED	8
-	1	2217206-7	BLADE, SLUG	7
-	-	-	-	6
-	1	238011-8	BLOCK, CRIMPER SPACER	4
1	1	2-2119582-4	CRIMPER, INSULATION F PREMIUM	3
-	1	1-455888-8	SPACER, CRIMPER	2
1	1	456408-8	CRIMPER, WIRE PREMIUM	1
-	77-22	PART NO	DESCRIPTION	ITEM NO

DIMENSIONS: mm		TOLERANCES UNLESS OTHERWISE SPECIFIED:		DWG: Y. YIN 29APR2014		CHK: G. BAILEY 29APR2014		APVD: J. GUO 29APR2014		NAME: Ocean End Feed Applicator	
0 PLC	±	1 PLC	±	2 PLC	±	3 PLC	±	4 PLC	±	SIZE	CAGE CODE
ANGLES	±	FINISH	±	WEIGHT	-	SCALE	1:1	SHEET	3	OF	4
Customer Accessible Production Drawing										REV	D

LOC		DIST		REVISIONS				
P	LTN	DATE	DMN	APVD	DESCRIPTION	DATE	DMN	APVD
-	-	-	-	-	SEE SHEET 1	-	-	-

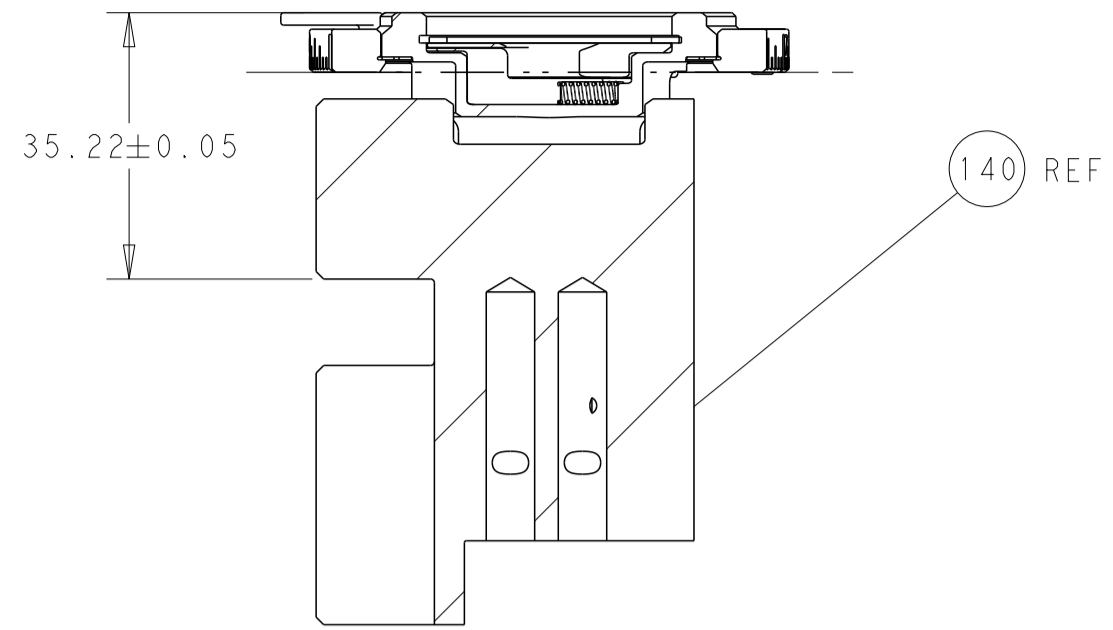

RAM SET-UP

FEED TYPE

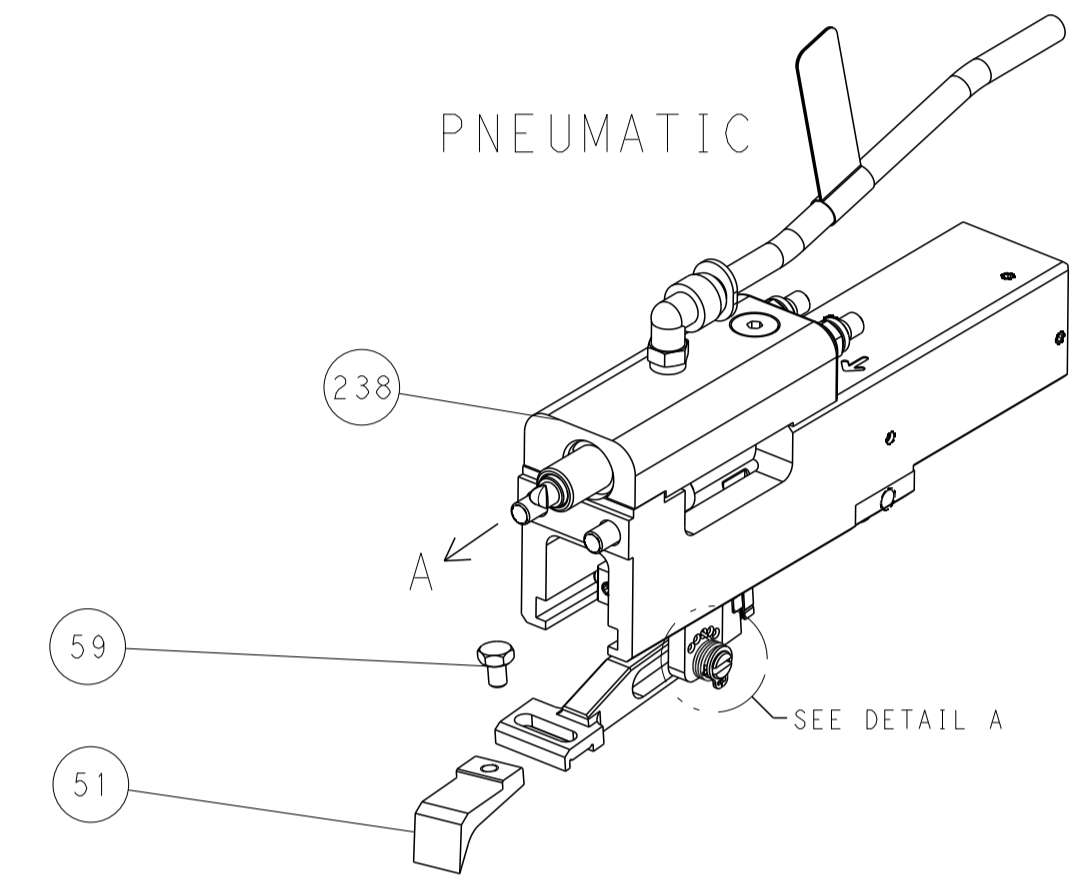
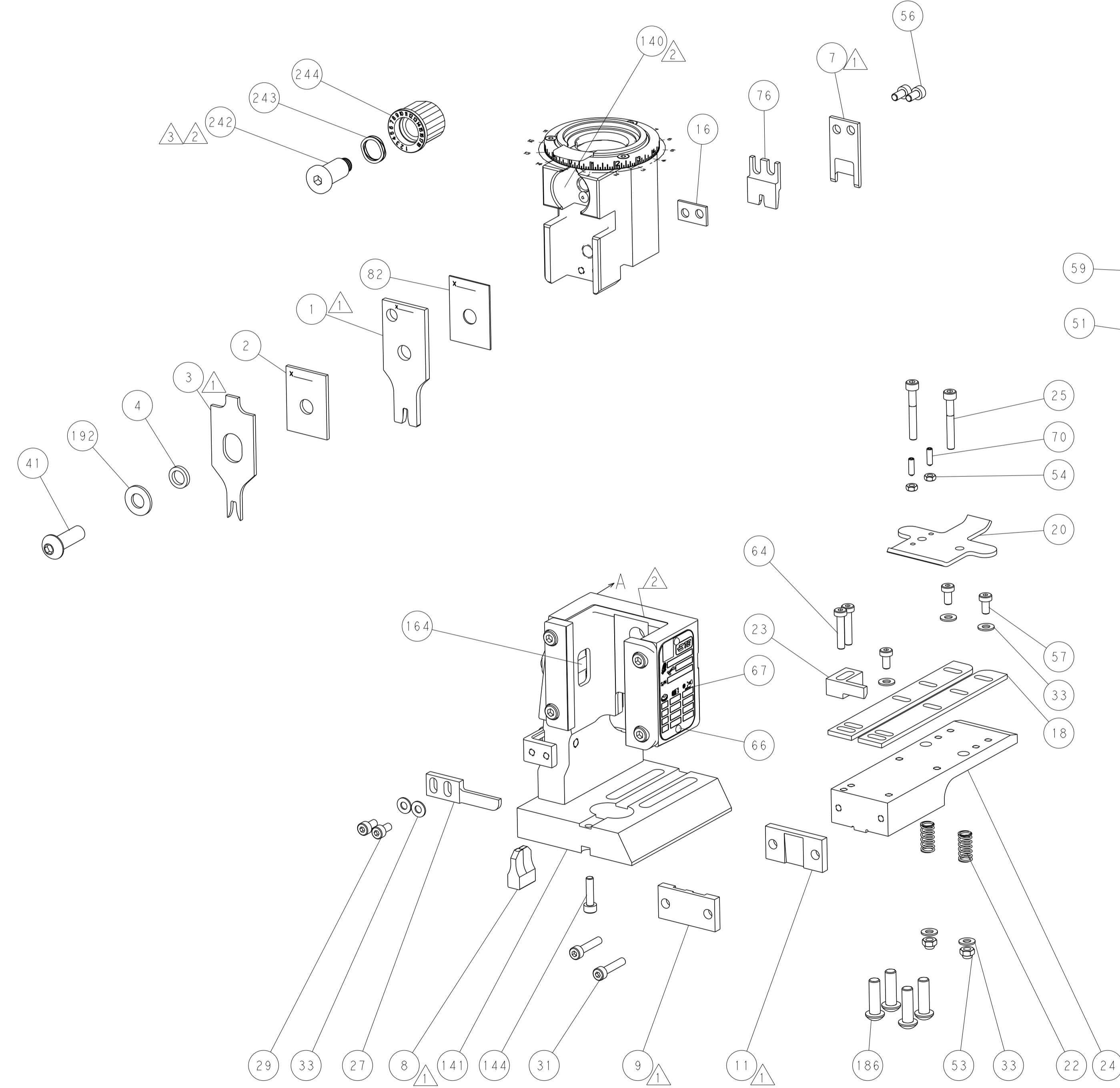

FEED SPRING SETTING POSITION

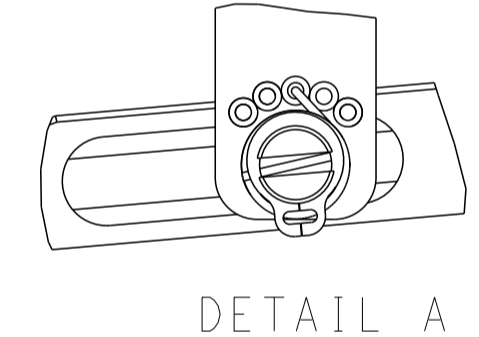

CAM POSITION

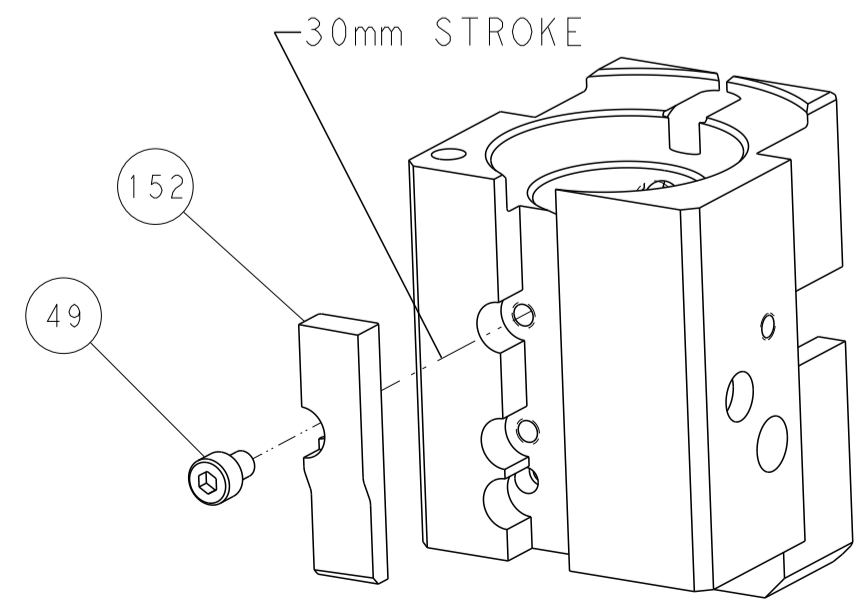

AIR FEED

PACIFIC VERSION
 Shown on sheets 3 of 4 & 4 of 4
 (Atlantic version shown on sheets 1 of 4 & 2 of 4)

DIMENSIONS: mm 		TOLERANCES UNLESS OTHERWISE SPECIFIED: 0 PLC ± 1 PLC ± 2 PLC ± 3 PLC ± 4 PLC ± ANGLES ± FINISH		DWN Y. YIN 29APR2014 CHK G. BAILEY 29APR2014 APVD J. GUO 29APR2014 PRODUCT SPEC APPLICATION SPEC WEIGHT Customer Accessible Production Drawing		NAME Ocean End Feed Applicator SIZE CAGE CODE DRAWING NO A1 00779 C=2150436 SCALE 1:1 SHEET 4 OF 4 REV D		STE TE Connectivity Harrisburg, PA 17105-3608	
-----------------------	--	---	--	--	--	--	--	--	--