

SPECIFICATION

Part No. : **CAB.0114**

Product Name : Taoglas Cable Assembly
SMA(F) Bulkhead Straight to
SMA(M) Plug Straight
with 75mm RG-174 cable

Photo :

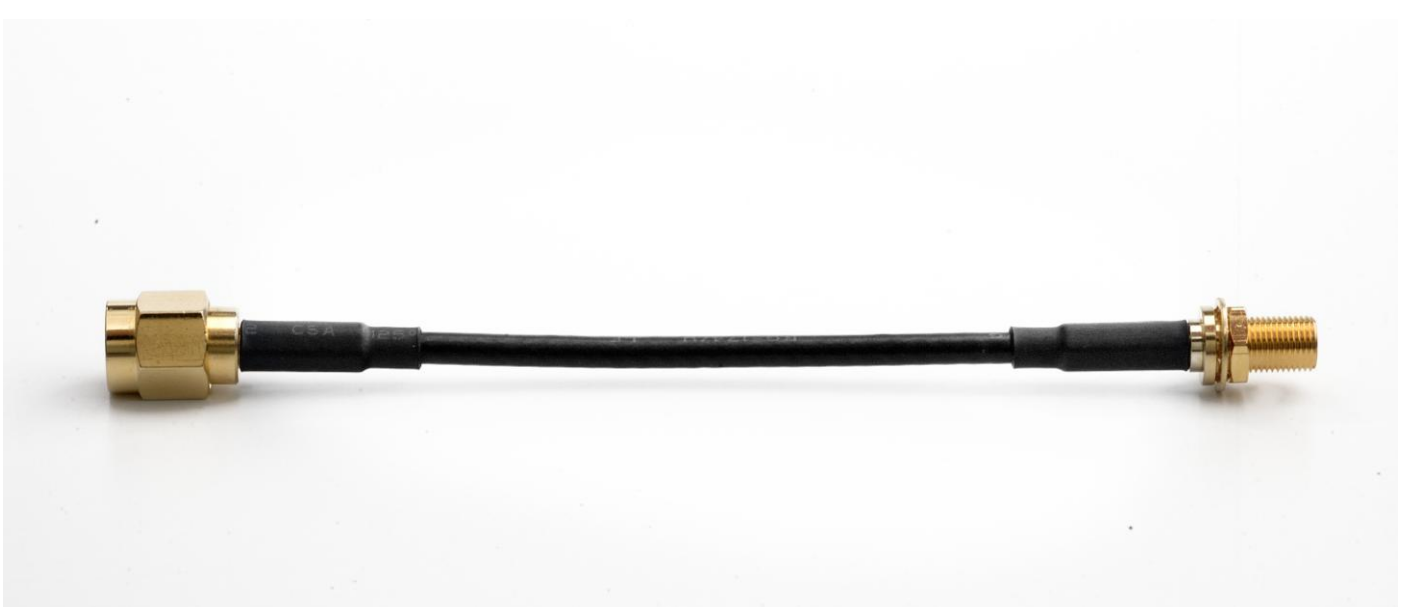

1.0 Cable Insertion Loss

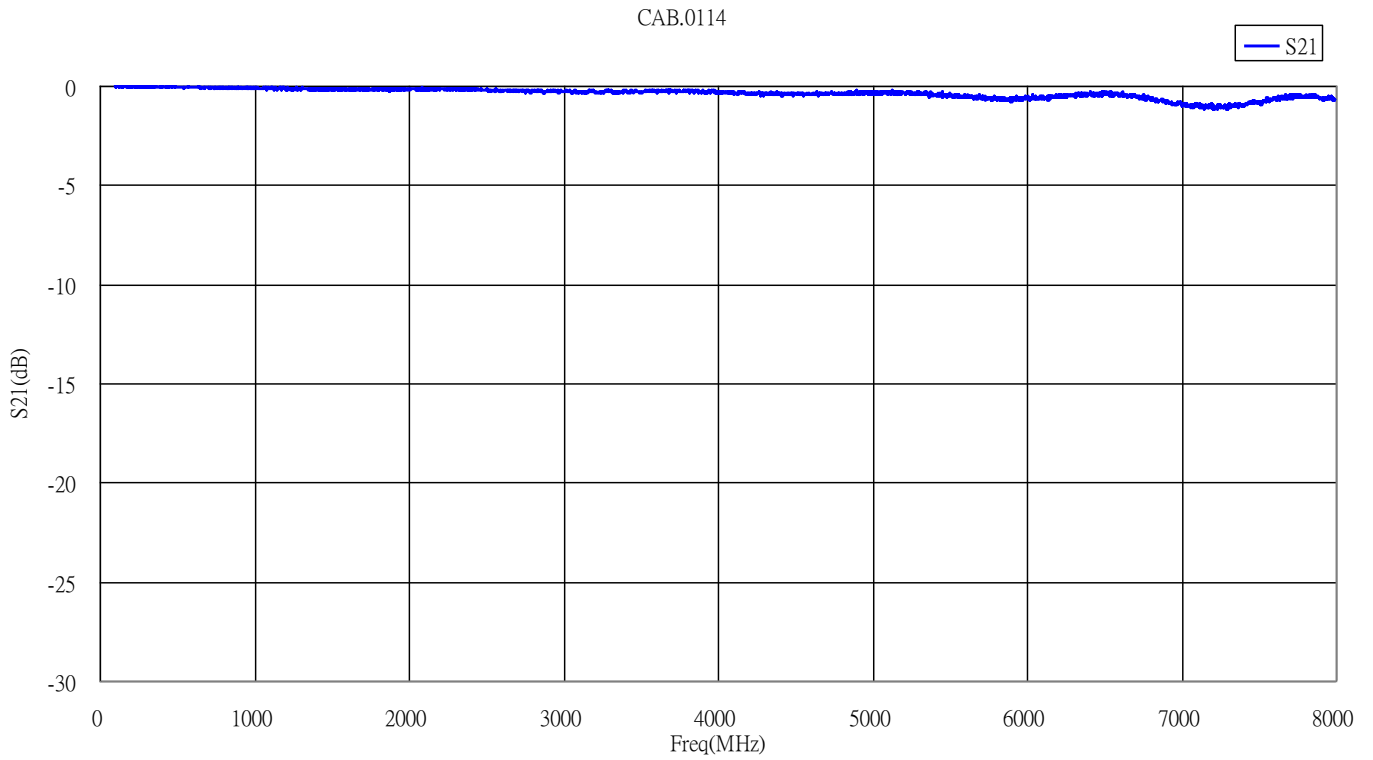

2.0 RG-174 Cable Specification

2.1 Drawing – Cross Section



2.2 Structure and Dimensions



2.3 Electrical & Physical Specification

1	Temperature rating:	80°C
2	Voltage Rating:	30V
3	Insulation Resistance:	10MΩ-Km (Min) at 20°C dc 500V(EIA-364-21)
4	Conductor Resistance:	20°C 26 AWG: 148.96 Ω/Km (Max)
5	Capacitance:	30.8pf/ft
6	Dielectric Strength	AC 500V/1 minute no breakdown (EIA-364-20)
7	Impedance:	10MHz~3GHz 50 ± 5 Ω
8	Standard Attenuation:	100MHz 8.4 dB/100ft
		200MHz 12.5 dB/100ft
		400MHz 19.0 dB/100ft
		900MHz 31.0 dB/100ft
		1GHz 34.0 dB/100ft
		1.8GHz 49.4 dB/100ft
		2.34GHz 53.0 dB/100ft

3.0 Technical Drawing

3.1 CAB.0114

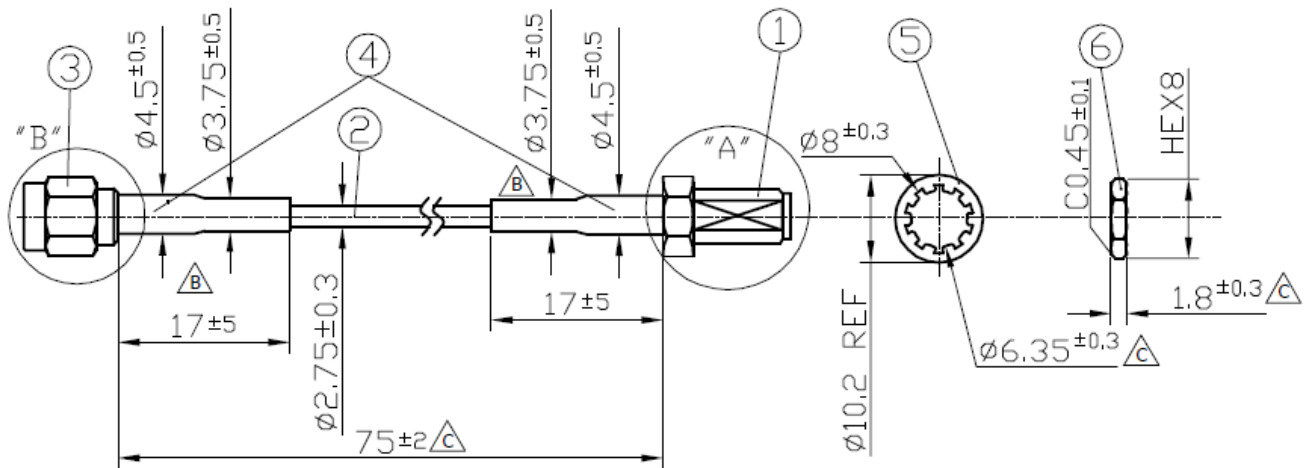

	Name	Material	Finish	QTY
1	SMA(F) Bulk Head ST	Brass	Gold	1
2	RG174	PVC Jacket	Black	1
3	SMA(M) ST	Brass	Gold	1
4	Heat Shrink Tube	PE	Black	2
5	Washer	Brass	Gold	1
6	Nut	Brass	Gold	1

3.2 Connectors

