

General Description

The DME 635 is a standalone 3D-TOF Distance Measurement Camera with a resolution of 160x60 pixel (Half-QQVGA). It is a highly integrated camera system with a wide field of view (FOV). The operating range is up to 17m on white objects. The camera system is a combination of a epc635 sensor board including a lens system, an LED illumination board and a BeagleBone Black host controller board. Even for mobile devices, only a few additional components are needed to integrate this 3D camera, e.g. a housing.

The host controller operates the epc635 in all available operation modes and reads the distance values over the TCMI communication. The controller reads the imager data, applies calibration and compensation algorithms and delivers the results to an external computer via its integrated API. It is also possible to operate the DME 635 as a standalone sensor system. In this case, application software can be downloaded and run on the BeagleBone Black board also by using the full software framework like the operating system and the 3D-TOF API.

128 full frame TOF images are delivered by the epc635 camera chip in maximal configuration. By using advanced operation modes, this can be boosted up to more than 512 TOF images per second! The high degree of integration lays base for straight-forward system integration with minimal part count. The extremely high sensitivity of the optical front end allows to operate with a low power illumination subsystem which reduces the power consumption of the overall system significantly.

The camera comes with a fully documented SDK based on open-source SW and HW.

Features

- 160 x 60pixel (Half-QQVGA)
- Wide field of view H50° x V19°
- Up to 17m distance measurement range on white targets
- Low power consumption
- Robust and stable
- High speed USB or ETHERNET interface
- Linux server with 3D-TOF API

Applications

- People detection and counting
- Parcel size measurement
- Machine safety
- Object recognition
- Automatic door safety
- Humanoid robotics
- Helicopter near terrain flight assistance
- Man-Machine interface
- Gesture control
- Body size measurement
- General volumetric mapping



Figure 1: DME 635

1. Precaution and Safety



Eye safety: Do not look directly into the camera under operation. Depending on the mode of operation, the camera device emits highly concentrated non-visible infrared light. It can be hazardous to the human eye. The use of these devices has to follow the safety precautions given in IEC 60825-1 and IEC62471.



The DME 635 is a bare electronic device without a housing around. Therefore, handle it with the necessary ESD precaution.



Over-voltage: Use only power supplies which corresponds to the datasheet DME 635 to avoid damage of the DME 635 or cause danger for humans.



Cable-tripping: Place the DME 635 with a tripod on a flat solid ground or fix it correctly on a solid support. Place cables carefully. Falling devices can be damaged or harm persons.



This camera comes with its own calibrated firmware. For proper operation of the camera, upload the correct firmware with the evaluation kit to the camera according the instructions given in the quick guide. Do this when you are changing the camera module.



This camera comes with high quality lens. Do not touch, twist or turn it. Otherwise loss of performance occurs.



EMC compatibility: The DME 635 is designed on module level. It is not an EMC certified device. It is users responsibility to operate it in compliance with the EMC regulations.



The DME 635 is designed on module level. It is NOT a CE, UL, CSA certified device. It is the users responsibility to operate it in compliance with the relevant regulations.



The DME 635 and its software may only be used in accordance of the datasheet DME 635



This devices may not be used in safety applications, explosive atmospheres or in radioactive environment.



Limited warranty - Loss of warranty

The DME 635 should only be installed and used by authorized people. All instructions in this datasheet and in the related documents shall be followed and fully complied with. In addition, the installer and user is required to comply with all local laws and regulations. Should any of these instructions not be carefully followed, seriously injury may occur. The installer and user is fully responsible for the safe use and operation of the system. It is the sole responsibility of the installer and the user to ensure that this product is used according to all applicable codes and standards in order to ensure safe operation of the whole application. Any alteration to the devices by the buyer, installer or user may result in unsafe operating conditions. ESPROS Photonics AG is not responsible for any liability or warranty claim which results from such manipulation or disregarding of given operating instructions.

ESPROS Photonics is constantly striving to provide comprehensive and correct product information. Therefore, please check our website regularly for updated versions of datasheets and documentations: www.espros.com



Download the actual Datasheet epc635: www.espros.com → Downloads → Datasheets → Chips.



Download the actual Datasheet DME 635: www.espros.com → Downloads → Datasheets → Camera_and_Modules.



Download the current GUI software (client) and the current BeagleBoneBlack software (server).
Questions: Send an email with your request to your local sales office or to info@espros.com.



Update the DME 635 (BeagleBone board): Go to the folder "ESPROS_TOF-imager_Evaluation_Kit_Software_vX.X.X". Read the Readme-file and follow the instructions accordingly.

Table of Contents

1. Precaution and Safety	2
2. The DME 635 Distance Measurement Engine	4
2.1. System overview	4
2.2. Scope of Delivery	5
2.2.1. Bill of Material	5
2.2.2. Documentation	5
3. Ordering Information	6
3.1. Notes for various DME 635 versions:	6
4. Technical Data	7
4.1. Recommended operating conditions	7
4.2. Optical Power Data	7
4.3. Distance Measurement Timing	8
4.4. Absolute Maximum Ratings	9
5. Interfaces	9
5.1. Connectors	9
5.2. Indicators and reset button	10
5.2.1. Status LEDs	10
5.2.2. Monitoring LEDs	10
5.2.3. Reset button on BeagleBone	10
5.2.4. Reset button on TOF cape	10
6. Mechanical Properties	11
6.1. Part list	11
6.2. Mechanical / Optical Properties	11
7. Electrical Circuits	12
7.1. epc635 Card-edge Connector Chip Carrier	12
7.1.1. Schematics	12
7.2. PCB Layout	13
7.3. Pin Table	14
8. TOF Cape	15
8.1. Schematics	15
8.2. PCB Assembly	16
8.3. Pin Table J8 & J9	17
9. LED Cape	18
9.1. Schematics	18
9.2. PCB Assembly	19
10. BeagleBone Black Board	20
10.1. System Overview	20
10.2. Modification on BeagleBone board	20
10.3. Documentation	21
11. Installation and Setup	21
11.1. Mechanical fixation	21
11.2. Setup of the DME 635	21
11.3. Software Tools	21
11.4. Exchange of epc635 CC Chip Carrier	21
12. epc635 Evaluation Kit	22
12.1. Scope of Delivery	22
12.2. Ordering Information	22
13. Maintenance and disposal	24
13.1. Maintenance	24
13.2. Disposal	24
14. Addendum	24
14.1. Related documents	24
14.2. Links	24
14.3. Licenses	24

2. The DME 635 Distance Measurement Engine

2.1. System overview

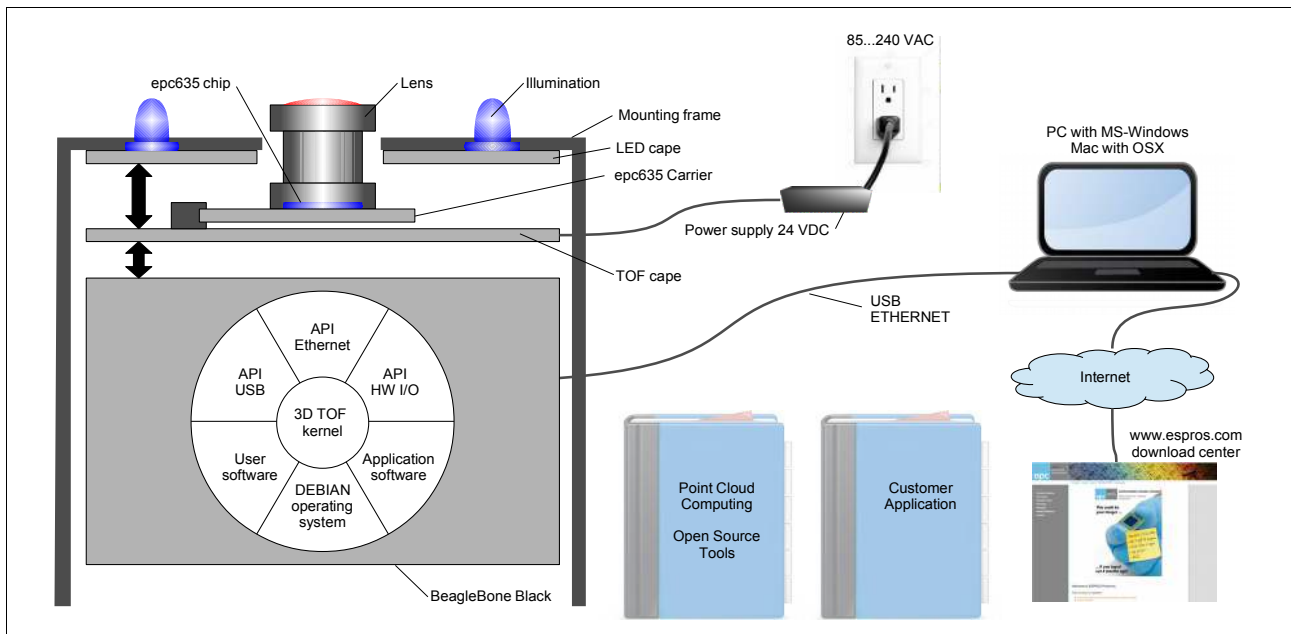

Figure 2: System overview

The DME 635 is a general purpose camera module based on the epc635 chip:

- The camera is based on a BeagleBone Black (BBB) Linux computer board.
- The TOF cape board communicates with the BBB and carries the epc635 CC Chip Carrier board with the epc635 camera chip and the lens with the lens holder. It carries also the single wire power supply for the whole camera system.
- The camera's active illumination is done by 8 power LEDs on the LED cape which is driven by the TOF cape. The LED cape's metal frame offers two camera mount 1/4" - 20UNC.
- The application software runs on the DEBIAN GNU/Linux operating system. The 3D-TOF kernel manages the camera including correction algorithms. Data for further processing e.g. cloud computing is available on APIs (application programming interface) for USB, Ethernet interfaces or hardware I/O. It opens the world for point cloud computing, using open source tools or creating own customer applications.

2.2. Scope of Delivery

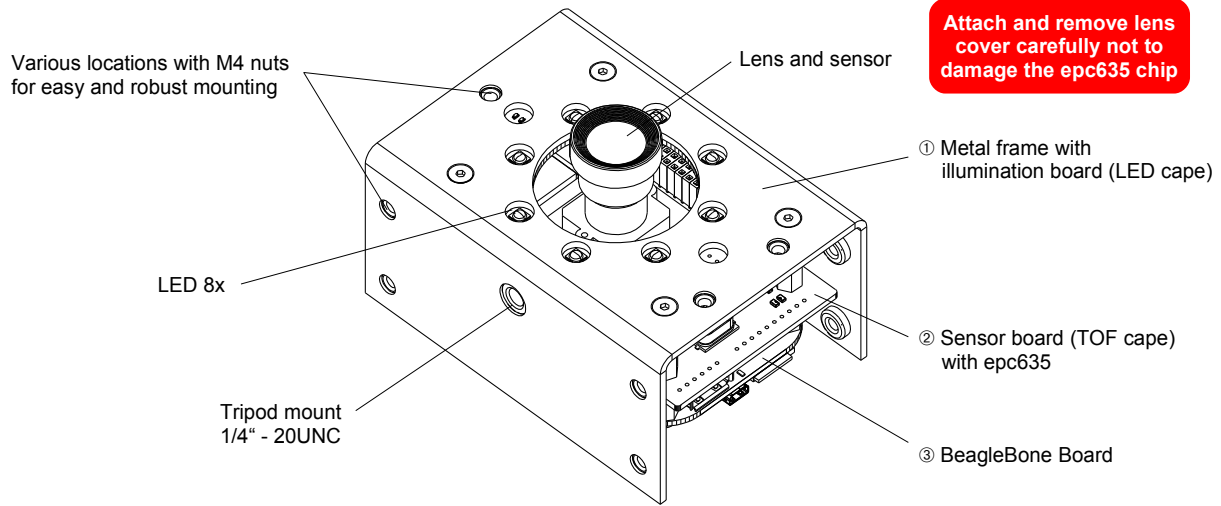

Figure 3: DME 635 overview

2.2.1. Bill of Material

No.	Designation	Remarks
①	Metal frame with camera/tripod mount 1/4" - 20UNC	Use only the 1/4" - 20UNC or the M4 tread inserts for mounting the camera
	LED cape: Illumination board	on Metal frame
②	TOF cape: Sensor board	on LED cape
	epc635-CSP44 chip (P/N P100 181) assembled on CC Chip carrier (P/N P100 404)	on TOF cape
	Lens Holder, M12-Mount with 860nm Filter (P/N P100 410)	on epc635 CC Chip Carrier board, includes optical bandpass filter 860nm
	Lens for DME 635 (P/N P100 506): - FOV: H50°, V19° - Lens with non-linear distortion - EFL 3.7mm (center) - F1.3 - 1/2" - M12mount	on lens holder, including lens cover other lens types upon request
③	BeagleBone Black board	Host controller

2.2.2. Documentation

Designation	Remarks
Datasheet DME 635	available at www.espros.com → Downloads
Datasheet epc635	available at www.espros.com → Downloads
Application and configuration software	Use the epc635 Evaluation Kit for accessing licensed corresponding tools and software development kit (SDK).

Table 1: Bill of material of the delivery

3. Ordering Information

Part Number	Part Name	Remark	RoHS compliance
P100 519	DME 635-50°/17m/bp860nm	completely assembled, tested and calibrated	Yes

Accessories:

Part Number	Part Name	Remark	RoHS compliance
P100 404	epc635 CC Chip Carrier	epc635 on chip carrier without optical filter	Yes
P100 506	Lens FOV 149°, 1/2", M12	Lens for DME 635: - FOV: H50°, V19° - Lens with non-linear distortion - EFL 3.7mm (center) - F1.3 - 1/2" - M12mount	
P100 410	Lens Holder, M12-Mount with 860nm Filter	includes optical bandpass filter 860nm	
	Optical bandpass filter	included in lens holder	

Table 2: Ordering Information

3.1. Notes for various DME 635 versions:

- The supplied DME version can be identified by reading the extension -XXX of the part name on the packaging labels or delivery papers: DME 635-XXX.
- This Datasheet is valid for DME 635 version -002 or later.
- Use the appropriate older version of the datasheet for former DME versions.

Support and technical contact: info@espros.com

4. Technical Data

4.1. Recommended operating conditions

($T_A = 25^\circ\text{C}$, $V_{\text{SUPPLY}} = 24\text{V}$, object reflectivity 90%, unless otherwise stated)

Parameter	Description	Min.	Typ.	Max.	Units	Comments
V_{SUPPLY}	Supply voltage	21.6	24	26.4	VDC	
V_{PP}	Ripple on the supply voltage V_{SUPPLY}			0.25	V_{PP}	Peak value must not below min. and not above max. supply voltage
I_{SUPPLY}	Supply current	Idle	0.10		A	after power up
		Grayscale imaging	0.10			100 fps
		3D-TOF imaging	0.25			100 fps, $t_{\text{INT}} = 600 \mu\text{s}$
	Image resolution	160 x 60			Pixel	
FOV	Field of view	H50 x V19			°	with lens P/N 100 506
λ	Operating wavelength	850			nm	
$f_{\text{LED_INT}}$	Internal modulation frequency	0.675, 1.25, 2.5, 5, 10, 20			MHz	Software controllable
$f_{\text{LED_EXT}}$	External modulation input	1		80	MHz	
d	Operating range	0.00		17.0	m	Measured with an object that has a size at least the size of the pixel (d_{PIXEL}). It is depending on the integration time t_{INT} and the object reflectivity.
Out	Distance output word	12			Bit	
Res	Resolution		0.5		cm/LSB	at 10 MHz modulation frequency
	Measurement output	0		2'000	LSB	at 10 MHz modulation frequency, refers to 0.0 ... 10.0 m, measurement results depending on object reflectivity
d_{CAL}	Calibration distance		0.8		m	Output @ 0.8m = 900 LSB
V_{APM}	Amplitude	50		2'000	LSB	useful amplitude range
Φ_L	Ambient light suppression	0		130'000	Lux	indirect, depending on integration time and object distance, ABS on
	Data interface	USB 2.0 full speed or Ethernet				
T_A	Ambient temperature range (operation)	0		60	°C	

Table 3: Operating conditions

4.2. Optical Power Data

Parameter	Description	Min.	Typ.	Max.	Units	Comments
$E_{\text{e_PEAK}}$	Peak illumination irradiance			372	W/m^2	in 200mm distance to the front surface of the DME 635
$E_{\text{e_AVG}}$	Average illumination irradiance		108		W/m^2	in 200mm distance to the front surface of the DME 635

Table 4: Optical power data

The analysis of the photo-biological hazards show that the DME 635 emits radiation levels below the safety limits described in EN 62471. The calculated exposure level is below the limit for any exposure time at a distance of 200 mm or more. Therefore, the DME 635 can be assumed to be safe to the eye and skin in terms of the standard and would belong to the open group (RG0).

Refer also to the report "DME_660_Photobiological_Safety_Analysis.pdf" which can be downloaded from the ESPROS website.

4.3. Distance Measurement Timing

Figure 4 shows the general timing diagram. For a full range measurement cycle, four differential correlation samples (DCSn in Figure 4) have to be acquired. After each DCS acquisition, the image containing the DCS per pixel, has to be read out from the epc635 imager (Data readout in Figure 4). Once four DCS are acquired, the distance is calculated on the BeagleBone Black board and an image containing a point cloud is ready to through the API.

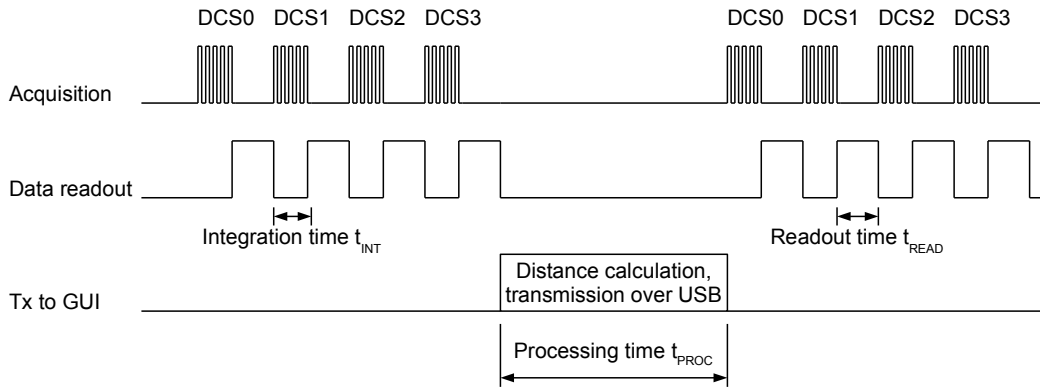

Figure 4: DME 635 measurement timing: 3D TOF with 4 DCS frames (standard API)

Parameter	Description	Min.	Typ.	Max.	Units	Comments
t_{INT}	Integration time selectable	0.1		4'000	μ s	
t_{READ}	Full frame image readout time (1 DCS)		1.9		ms	with 20 MHz TCMI data rate
t_{CYCLE}	Total distance measurement cycle time		36.9		ms	$T_{INT} = 600 \mu$ s
T_{PWR_UP}	Power up time		20		s	Refer to chapter 5.2

Table 5: Typical distance measurement timing parameters (refer to Figure 4)

There are various options to increase the frame rate:

Parameter	Description	Acquisition time reduction	Comments
No π -delay matching	DCS0 and DCS1 acquisition only	reduces the frame cycle by $2 * t_{INT}$ plus $2 * t_{READ}$	In-pixel non-linearities and asymmetries reduce the distance measurement quality
Dual MGX	Acquires the odd DCS' in the odd rows and simultaneously the even DCS' in the even row	reduces the frame cycle by $2 * t_{INT}$ plus $2 * t_{READ}$	Pixel tolerances in the even and odd rows reduce the distance measurement quality
No π -delay matching and Dual MGX	Acquires DCS0 in the even rows and simultaneously DCS1 in the odd row	reduces the frame cycle by $4 * t_{INT}$ plus $4 * t_{READ}$	see above

Table 6: Frame rate tuning options

Additional options are to modify the calculation software in the API and utilizing the 3D graphics accelerator and the NEON floating-point accelerator of the BeagleBone Black processor.

4.4. Absolute Maximum Ratings

Parameter	Conditions
ESD rating	Not classified. Handle it with the necessary ESD precaution.
Storage temperature range (T _s)	-40°C ... +85°C
Relative humidity	15 ... 95%, non-condensing

Table 7: Absolute maximum ratings

5. Interfaces

5.1. Connectors

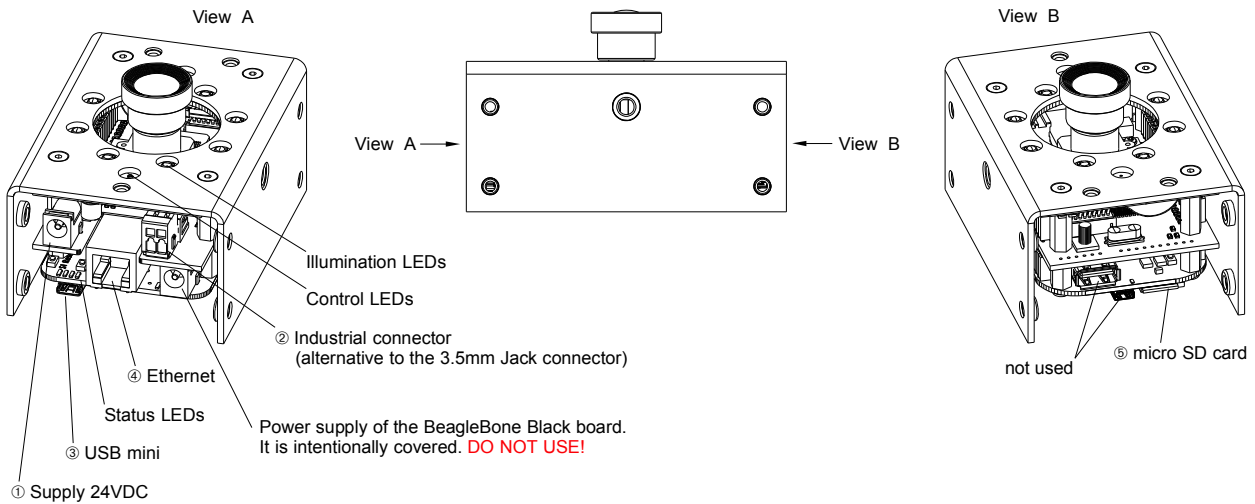

Figure 5: Connectors, status and control LEDs



No.	Connector	Plug	Remarks
①	Supply 24VDC / 2.5A	Power jack 5.0/2.1mm	for supply from power adapter 24VDC / 2.5A
②	Industrial supply	Power jack WAGO 3.5mm	for supply by industrial connection 24VDC / 2.5A
③	USB micro	Micro USB-B	 NEVER CONNECT THE USB CABLE AS LONG POWER IS NOT TURNED ON COMPUTER AND/OR THE CAMERA CAN BE DAMAGED! 
④	ETHERNET	RJ45	
⑤	Micro SD card		

Table 8: Connector list

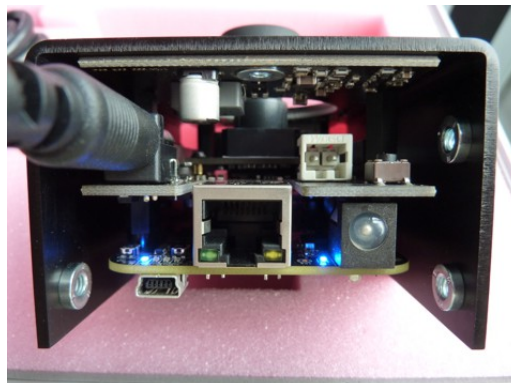

Figure 6: View to the connector side (USB and ETHERNET not connected)

5.2. Indicators and reset button

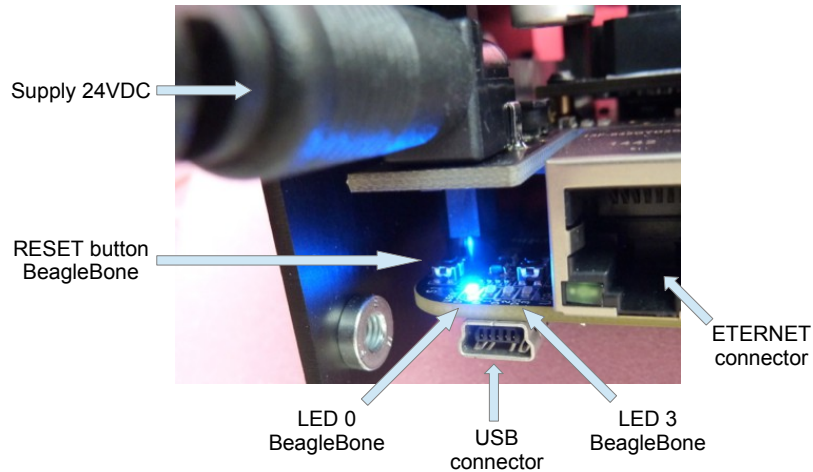

Figure 7: Status LEDs and RESET button

5.2.1. Status LEDs

Status	LED 0	LED 1	LED 2	LED 3	Remarks
Start-up DME 635 or BeagleBone: The blue status LEDs start flashing	☒	☒	☒	☒	After power up or RESET. Startup procedure of the board operating system. For details refer to the BeagleBone manual
After around 20s: Boot epc635 chip					
Trying to boot the epc635 chip	☒	☒	☒	■	Wait until LED 0 only (most left) is flashing only. LEDs 1 to 3 shall be off.
READY for handling requests	☒	□	□	□	Server successfully started on DME 635. Start communicating with the BeagleBone Black server by using either Ethernet or USB.
Regular operation:					
BUSY: Handles request of single command or video	☒	□	□	■	
READY again	☒	□	□	□	
Error message:					
Caught signal (Error), application closed	☒	■	■	■	Error detected by API. Reset the BeagleBone.

Table 9: Blue status LEDs on BeagleBone, refer to Figure 7

Notes:

- LED off
- ☒ LED flashing
- LED on

5.2.2. Monitoring LEDs

Red control LEDs on LED Cape, visible from the frontside; refer to Figure 5:

- D12: On if the LED cape is powered e.g. 3D TOF modes. **Safety advise: Be careful, IR LEDs are active during exposure.**
Off during modes having not an active illumination e.g. greyscale mode without active illumination.
- D13: On during integration period (exposure) independent of selected mode.

5.2.3. Reset button on BeagleBone

Resets the DME 635. Instead of the this button, the terminal command, as described in the "Readme" of the GUI source, can be used.

5.2.4. Reset button on TOF cape

Do not use. Resets the epc635 chip only. Lost of the synchronization with the BeagleBone board.

6. Mechanical Properties

6.1. Part list

No.	Part name	Qty.
1	BeagleBone Black Rev. C	1
2	Illumination board: LED cape	1
3	Distance sleeve M3/18mm, hole/hole, PA	4
4	Distance sleeve M3/12mm, bolt/hole, PA	4
5	Screw - cylinder head, cross recess, M3x6	4
6	Metal frame	1
7	Nut self-clinching	2
8	Sunk screw, M3x8	4
9	Lens FOV 149°, 1/2", M12	1
10	Connection Cable	1
11	Lens Holder, M12-Mount with 860nm Filter	1
12	Sensor board: TOF Cape	1
13	Screw - cross recessed, M1.6 x 3	2
14	Mounting pillar	2
15	Screw - cross recessed, M2x5	2
16	Female header Dip, 2.54, 180°	1
17	epc635 CC Chip Carrier	1
18	5.0/2.1mm DC Power Jack 24VDC / 2.5A	1
19	Industrial supply female plug	1
20	Industrial supply male connector	1
21	Micro SDHC card 16GB, programmed	1

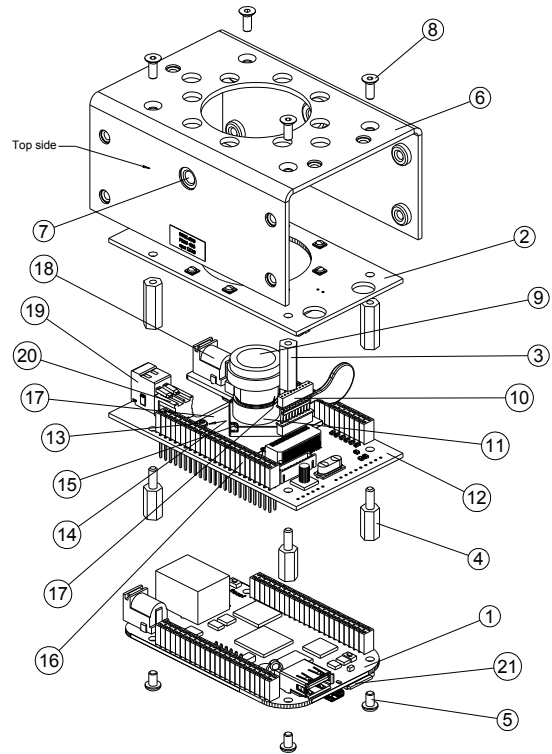

Figure 8: Part list and exploded view

6.2. Mechanical / Optical Properties

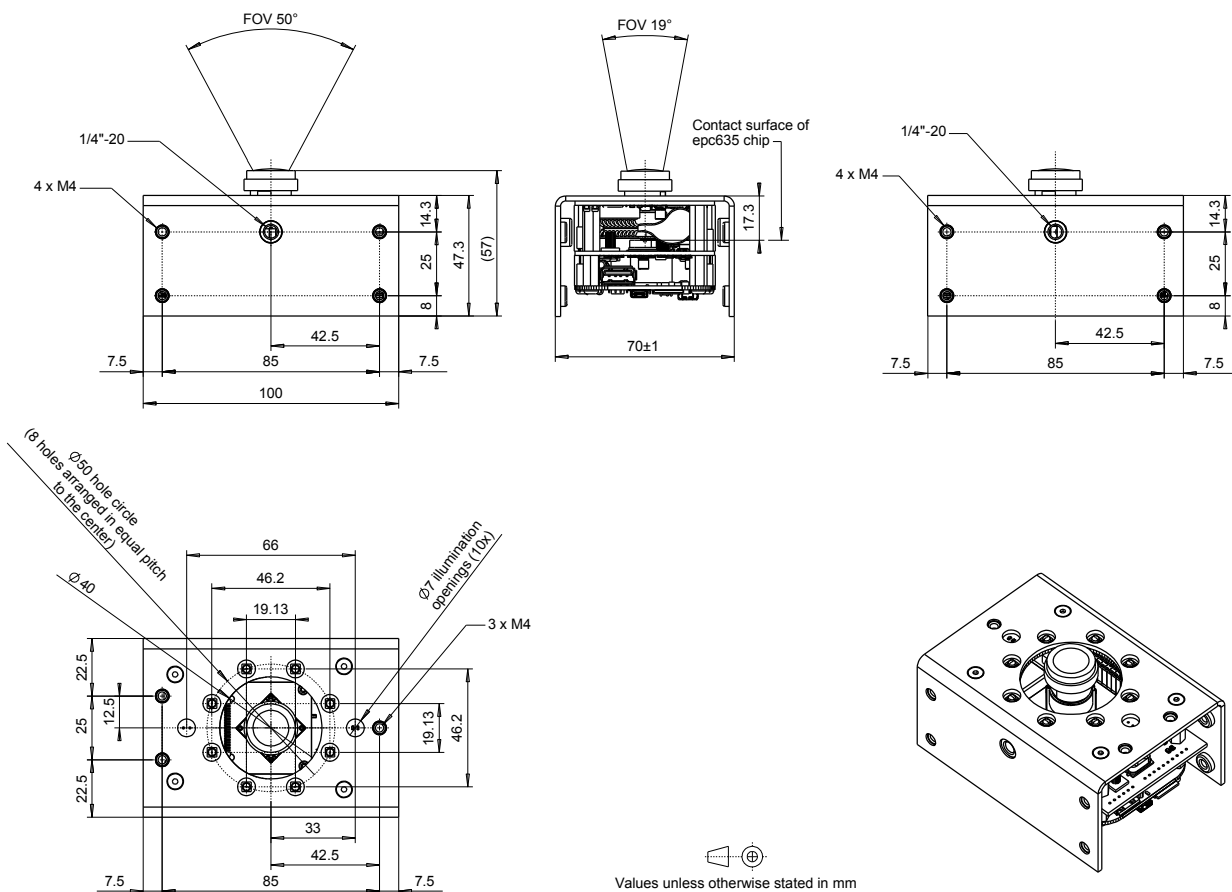

Figure 9: Reference dimensions of the optical axis and illumination

7. Electrical Circuits

7.1. epc635 Card-edge Connector Chip Carrier

7.1.1. Schematics

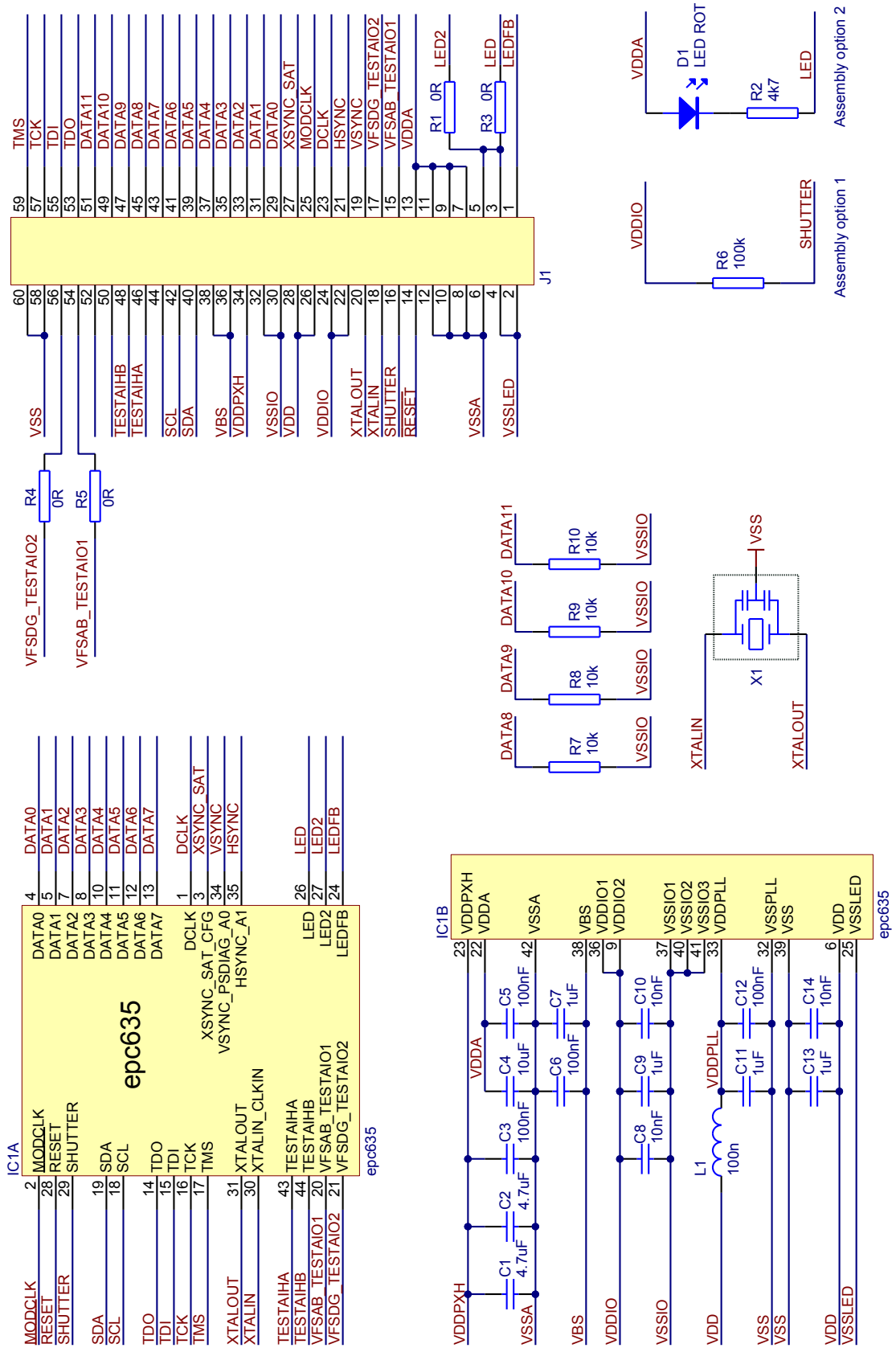

Figure 10: Schematic

7.2. PCB Layout

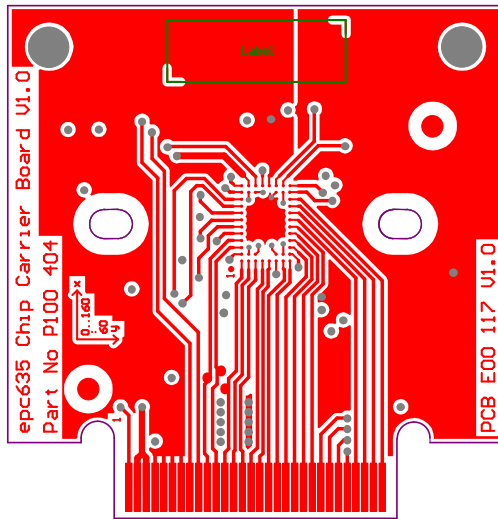

Figure 11: PCB layout top

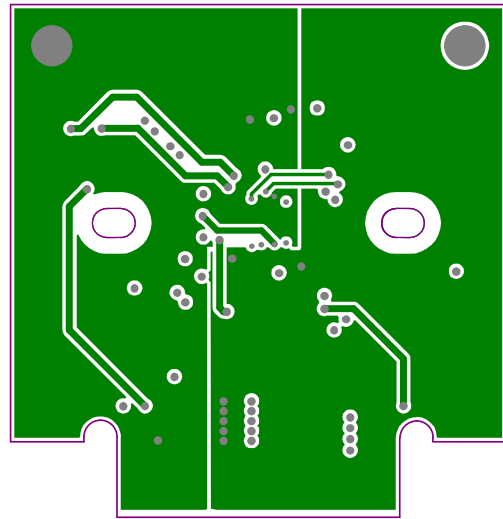

Figure 12: PCB layout top-middle

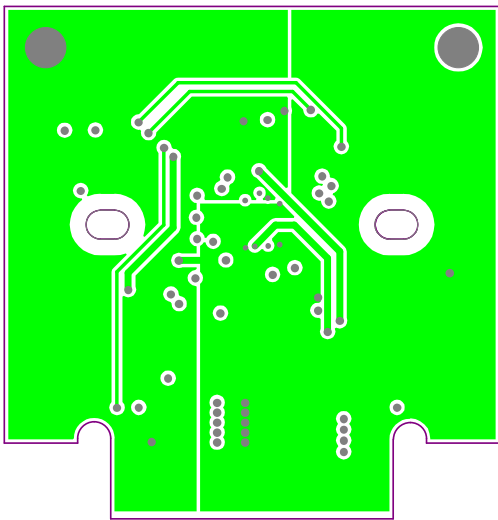

Figure 13: PCB layout bottom-middle

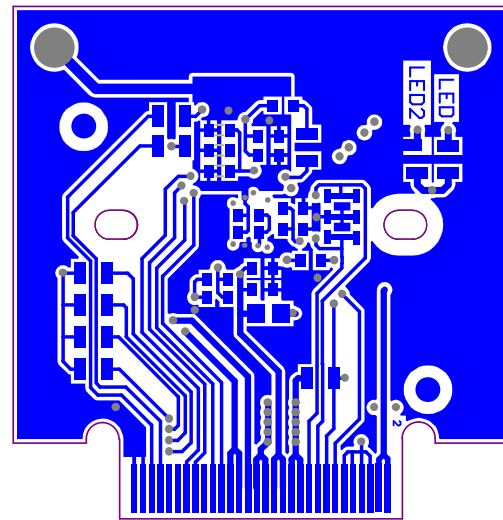

Figure 14: PCB layout bottom

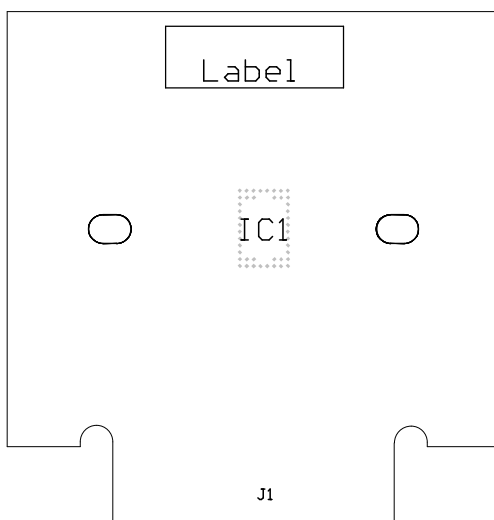

Figure 15: PCB assembly top

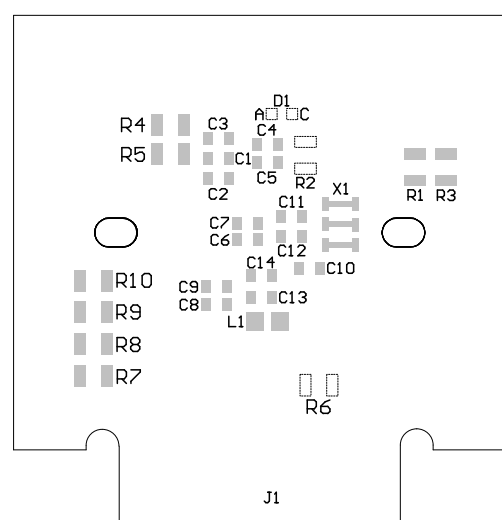

Figure 16: PCB assembly bottom

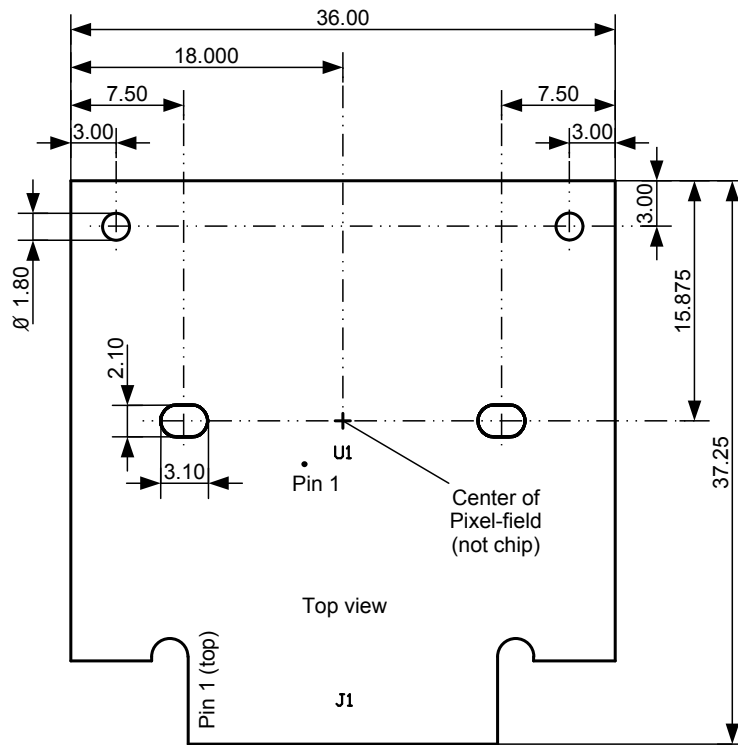

Figure 17: Mechanical dimensions PCB

7.3. Pin Table

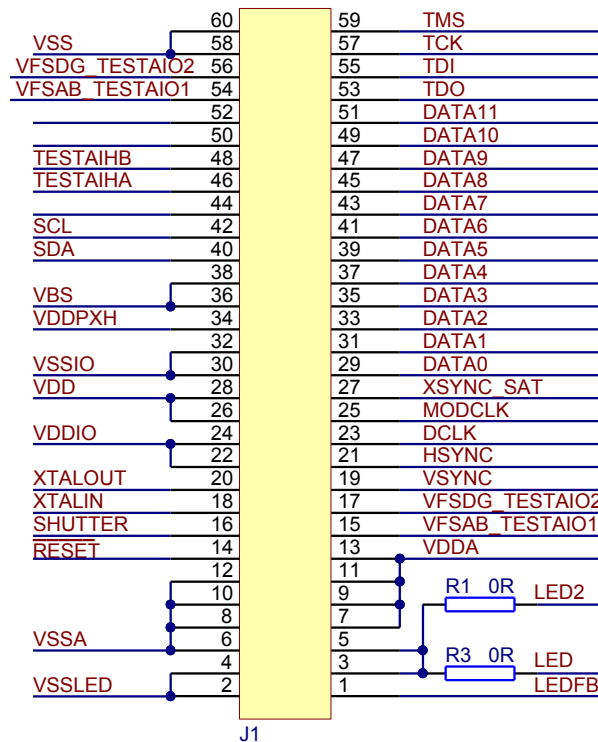

Figure 18: Pin table

Important note:

Use for connector J1 Pin 1 marking of schematic, PCB and assembly drawing. Pin 1 marking on connector housing J1 can deviate.

8. TOF Cape

8.1. Schematics

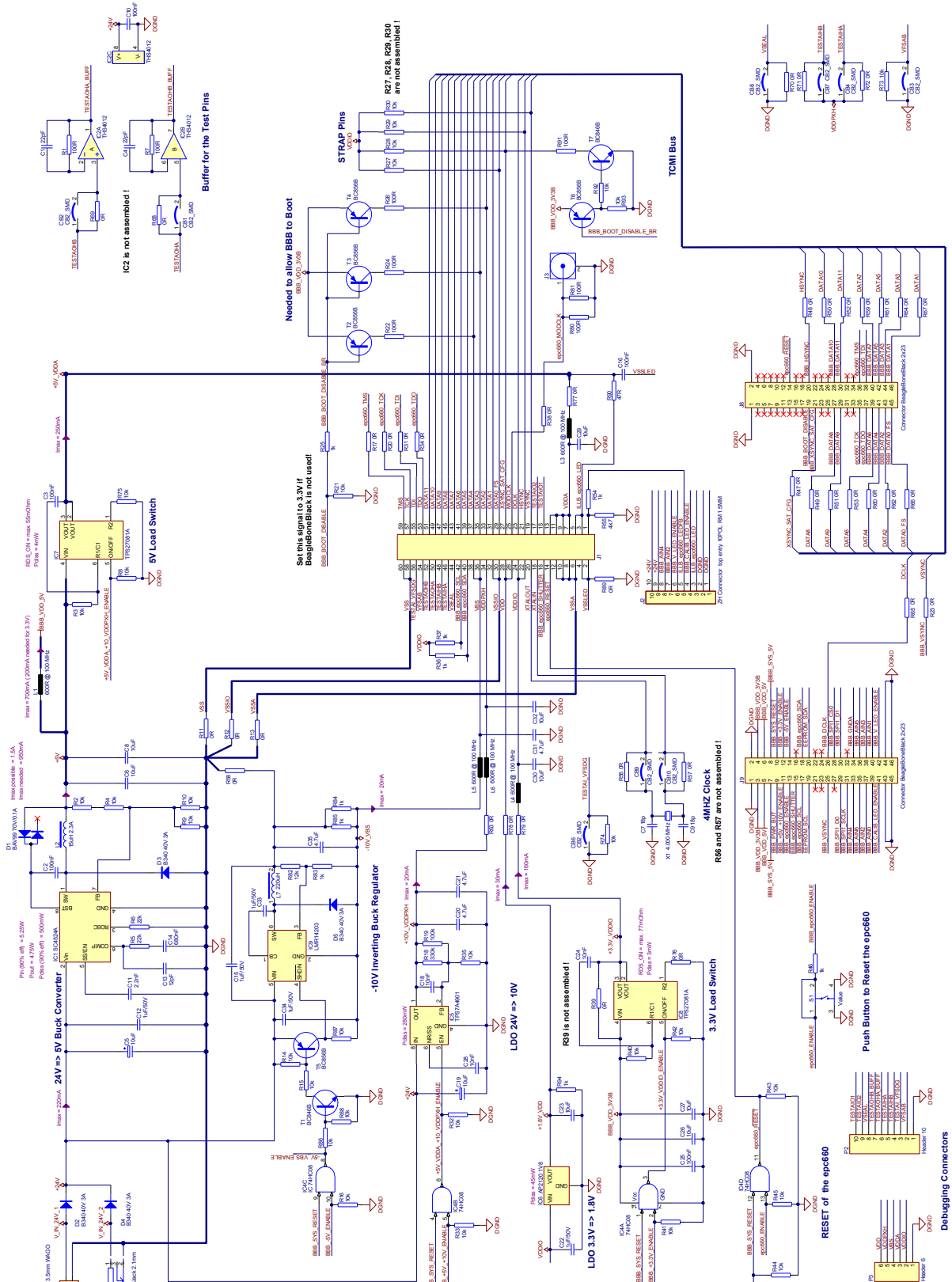

Figure 19: Schematic

Important note:
Use for connector J1 Pin 1 marking of schematic, PCB and assembly drawing. Pin 1 marking on connector housing J1 can deviate.

8.2. PCB Assembly

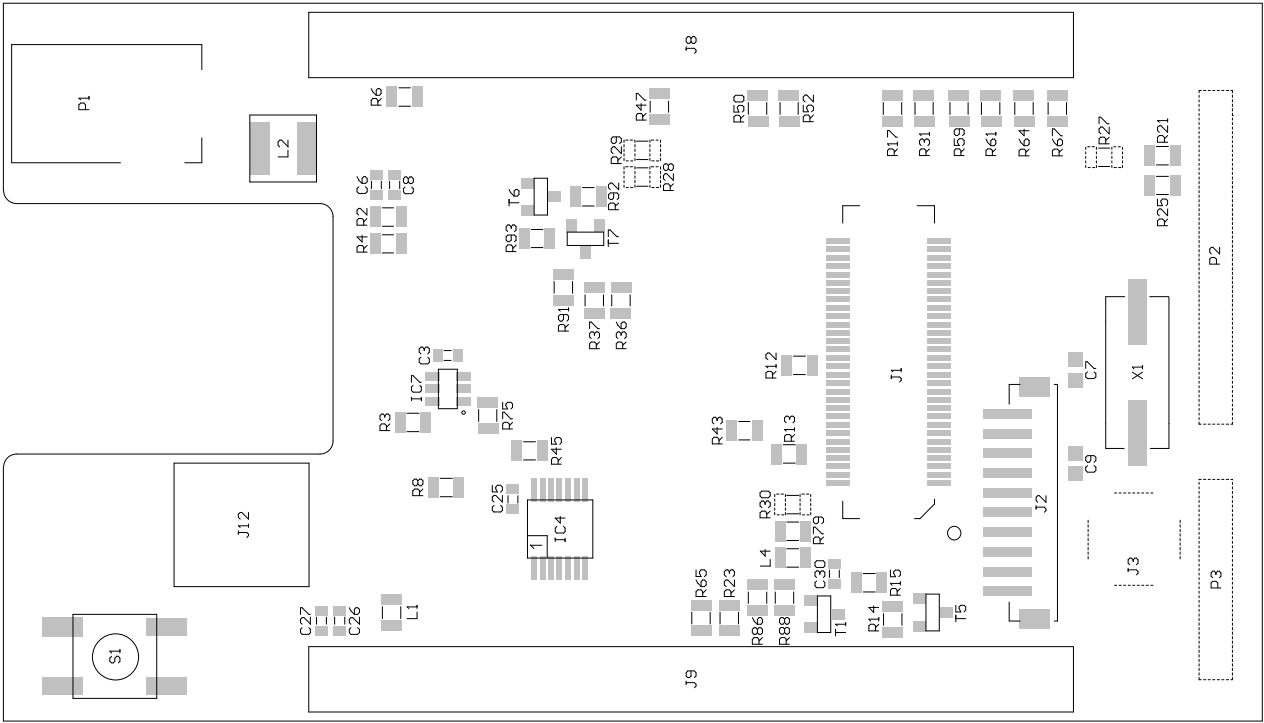

Figure 20: PCB assembly top

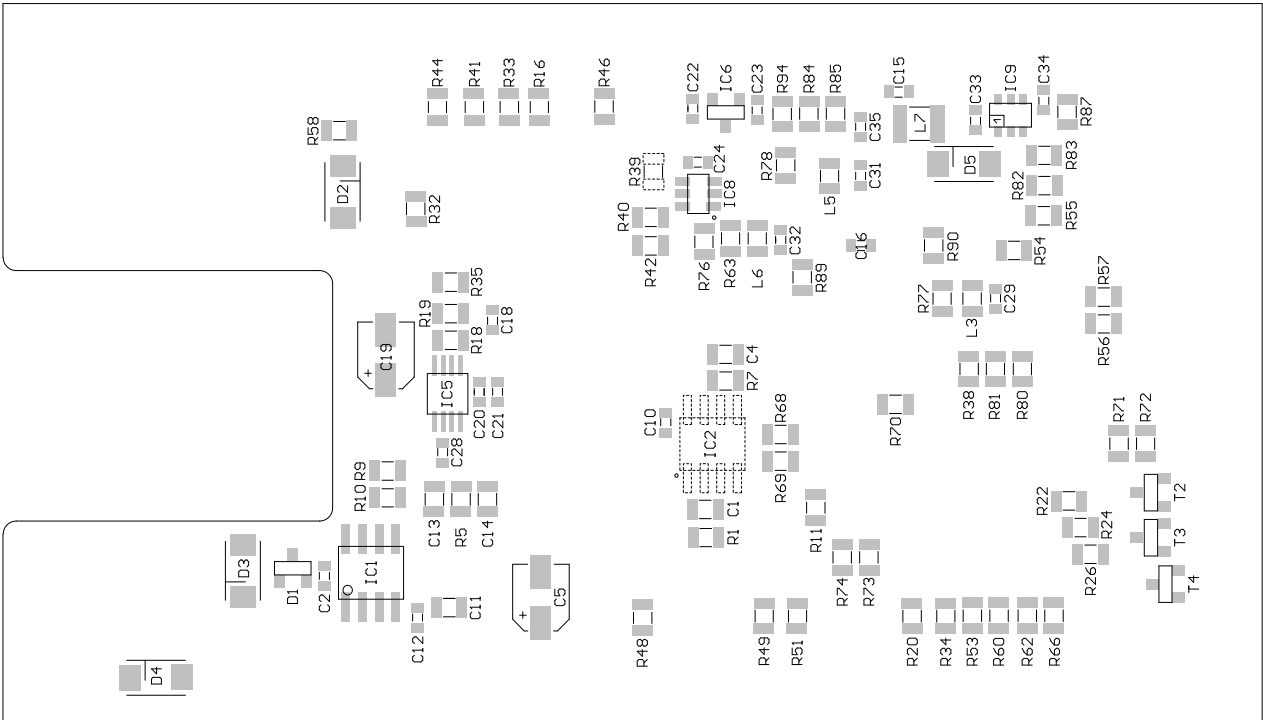

Figure 21: PCB assembly bottom

8.3. Pin Table J8 & J9

DGND	1	2	DGND	DGND	1	2	DGND
BBB_VDD_3V3B			BBB_VDD_3V3B				
BBB_VDD_5V			BBB_VDD_5V				
BBB_SYS_5V			BBB_SYS_5V				
BBB_PWR_BUT	9	10	BBB_SYS_RESET		9	10	
BBB_+5V_+10V_ENABLE			BBB_+3.3V_ENABLE				
BBB_epc660_ENABLE			BBB_-5V_ENABLE				epc660_RESETh
BBB_epc660_SHUTTER			---				
BBB_epc660_SCL			BBB_epc660_SDA				
EEPROM_SCL	19	20	EEPROM SDA	BBB_BOOT_DISABLE	19	20	BBB_HSYNC
---			---	BBB_XSYNC_SAT			
---			---				
BBB_VSYNC			BBB_DCLK				
---			BBB_SPI1_CS0	BBB_DATA8			BBB_DATA10
BBB_SPI1_D0	29	30	BBB_SPI1_D1	BBB_DATA9	29	30	BBB_DATA11
BBB_SPI1_SCLK			---				
BBB_AIN4			BBB_GNDA				
BBB_AIN6			BBB_AIN5	epc660_TCK			epc660_TMS
BBB_AIN2			BBB_AIN3	epc660_TDO			epc660_TDI
BBB_AIN0	39	40	BBB_AIN1	BBB_DATA6	39	40	BBB_DATA7
BBB_CALIB_LED_EN			BBB_V_LED_ENABLE	BBB_DATA4			BBB_DATA5
DGND			DGND	BBB_DATA2			BBB_DATA3
DGND			DGND	BBB_DATA0_FS			BBB_DATA1
	J9				J8		

Figure 22: Pin table J8 & J9

9. LED Cape

9.1. Schematics

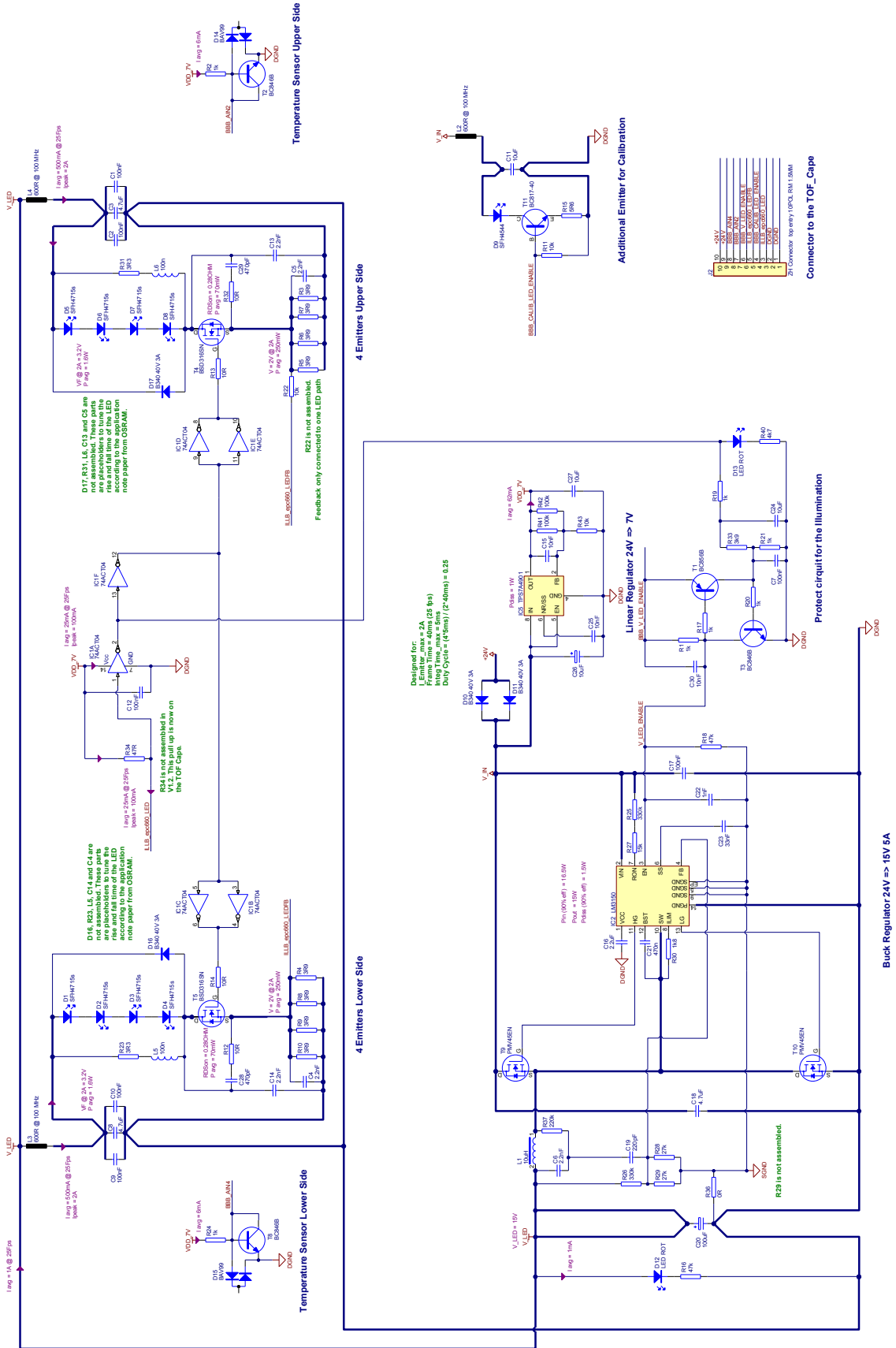

Figure 23: Schematics

9.2. PCB Assembly

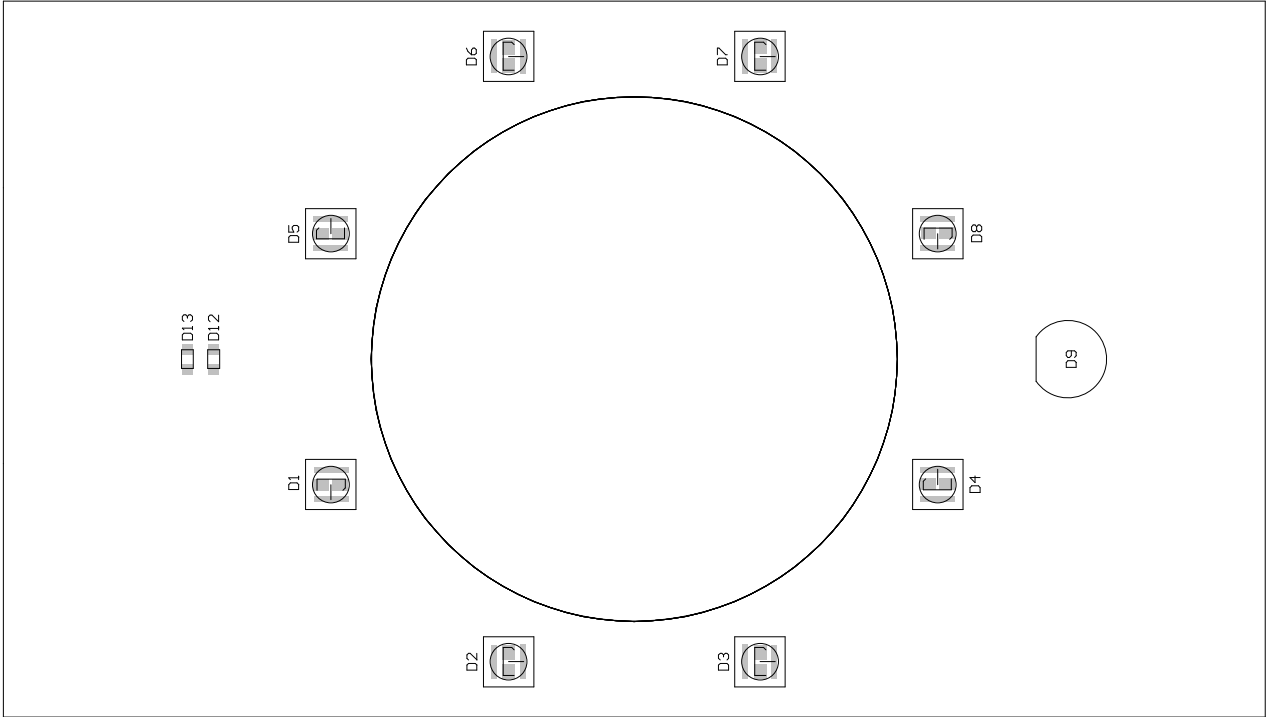

Figure 24: PCB assembly top

- D1..D8: Illumination LEDs
- D12, D13: Monitoring LEDs (red), refer to chapter 5.2.2, Monitoring LEDs

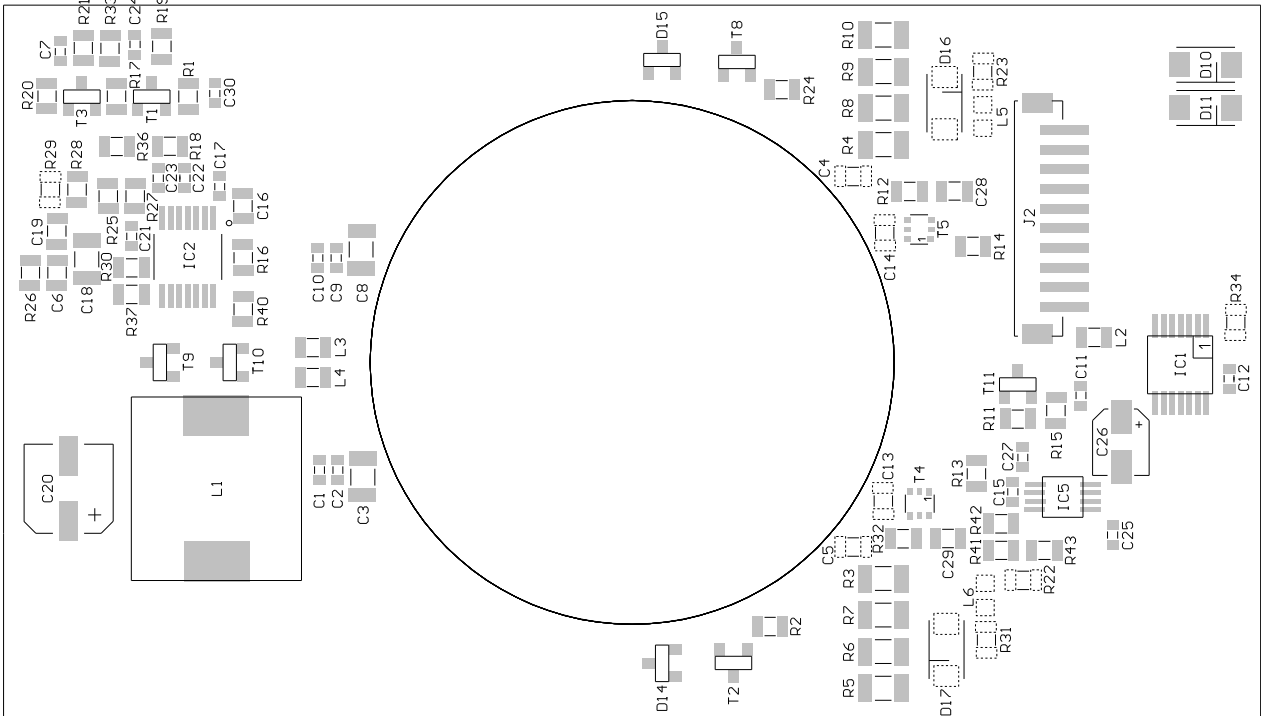

Figure 25: PCB assembly bottom

10. BeagleBone Black Board

10.1. System Overview

- Processor: AM335x 1GHz ARM® Cortex-A8
- 512MB DDR3 RAM, 4GB 8-bit eMMC on-board flash storage
- 3D graphics accelerator, NEON floating-point accelerator, 2x PRU 32-bit micro controllers
- USB client for power & communications, USB host, Ethernet
- Software Compatibility: Debian, Android, Ubuntu, much more
- Open-source tools:
 - Point Cloud Library (PCL); www.pointcloud.org
 - OpenCV; www.opencv.org

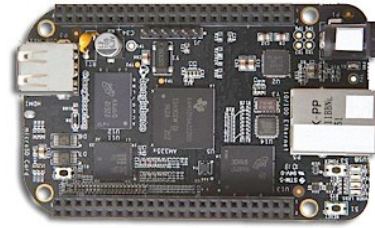

Figure 26: The BeagleBone Black board

10.2. Modification on BeagleBone board

The BeagleBone board is modified the following way for working properly in combination with the DME TOF cape.

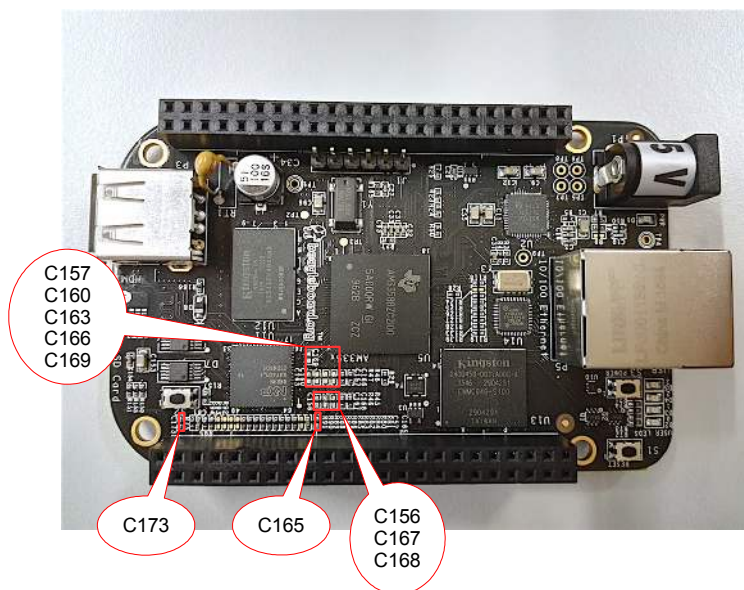

Figure 27: Marked capacitors are removed/disassembled from the Beagle Bone board top side

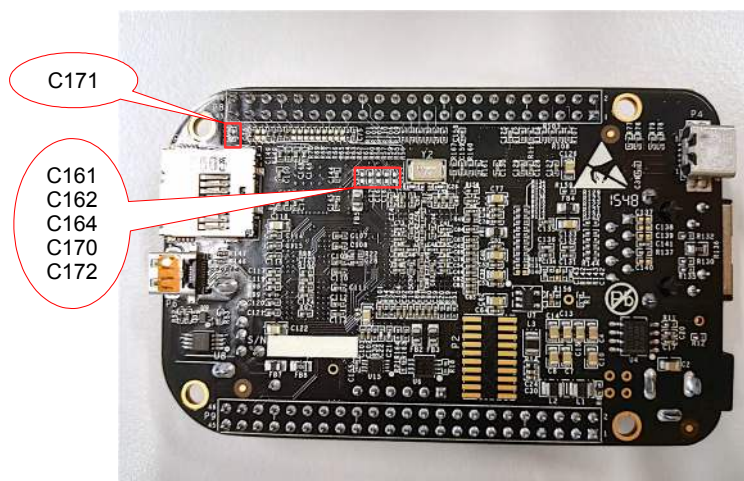

Figure 28: Marked capacitors are removed/disassembled from the Beagle Bone board bottom side

10.3. Documentation

Technical description of the BeagleBone Black board can be downloaded from www.beagleboard.org.

- BeagleBone Hardware Specs and Material, BeagleBone Black wiki
- BeagleBone Black System Reference Manual, BeagleBoard.org, 2014
- BeagleBone Black, Document No. 450-5500-001 (Schematics), BeagleBoard.org, 2014

11. Installation and Setup

11.1. Mechanical fixation

The DME 635 has various mounting options provided by the metal frame:

- On each long side
 - one tripod mount 1/4" - 20UNC, refer to Figure 3
 - four nut M4
- On top side: three nut M4

Use the options only to attach the DME 635 to a housing, a tripod or something else. Never use the threaded pillars or attach something directly to one of the PCB. You may damage the PCB.

11.2. Setup of the DME 635

The DME 635 can be operated by using the GUI software provided with the epc635 Evaluation kit. The setup described by the QUICK START GUIDE.

11.3. Software Tools

ESPROS Photonics supports the user's development and application by having available various support tools e.g. software development kit (SDK), updates and emulation program downloads for the epc635 chip, application interfaces (API), etc. They are available by contacting ESPROS by email at info@espros.com. The same way, the user can update the DME 635 (BeagleBone board) by using this service.

11.4. Exchange of epc635 CC Chip Carrier



Make sure, all assembly procedures are executed on an ESD-compatible workstation.

- Power off the DME 635 and remove cables
- Remove the BeagleBone board
- Remove the TOF cape
- Remove the locking screws from the epc635 CC Chip Carrier
- ⚠ Softly remove the epc635 CC Chip Carrier. The epc635 chip can be destroyed when excessive force is applied.
- Remove lens holder
- Attach the lens holder to the new epc635 CC Chip Carrier
- ⚠ Softly insert the new epc635 CC Chip Carrier
- Insert the locking screws for the epc635 CC Chip Carrier
- Install the TOF cape
- Install the BeagleBone board
- ⚠ First power on the DME 635
- Connect the USB cable
- Download and install the latest server software according the Readme.txt
- Start the epc635 Evaluation Kit GUI and run a black & white video (start)
- Unlock the fixation of the lens
- Adjust lens focus
- Lock the fixation of the lens
- Calibrate the DME 635 with this new chip carrier

12. epc635 Evaluation Kit

There is an evaluation kit available which supports the development of own applications on the DME 635 in terms of the evaluation of the optical performance parameters.

12.1. Scope of Delivery



Figure 29: epc635 Evaluation Kit overview

No	Pieces	Designation	Remarks
①	1	Toolbox	
②	1	DME 635-50°/17m	P/N P100 519; with quick release fastener of the tripod
③	1	Power Supply 24V/2.5A	
④	1	Power cord 2 pole EU version and US adapter	Power plug EU Europlug (CEE7/16, 2 pole) Power plug US Type A (NEMA 1-15, 2 pole)
⑤	1	Cable - USB 2.0, A plug - mini-B plug	Length 2m
⑥	1	Plastic bag with Industrial Supply Connector and the toolbox key	The connector can also be inserted in the DME 635
⑦	1	Camera Tripod	
⑧	1	Toolbox belt	
⑨	1	epc635 Evalkit Quick Start Guide	also available at www.espros.com → Downloads
		Datasheet DME 635	available at www.espros.com → Downloads
		Datasheet epc635	available at www.espros.com → Downloads
		Application and configuration software, SDK	Use the epc635 Evaluation Kit for accessing licensed corresponding tools and software development kit (SDK).

Table 10: Bill of material of the delivery

12.2. Ordering Information

Part Number	Part Name	Remarks
P100 411	epc635 Evaluation Kit EU & US	Power plug EU Europlug (CEE7/16, 2 pole) & US adapter

Table 11: Ordering Information epc635 Evaluation Kit



Figure 30: DME 635 on tripod



Figure 31: epc635 Evaluation Kit



Figure 32: DME 635 tripod mounting

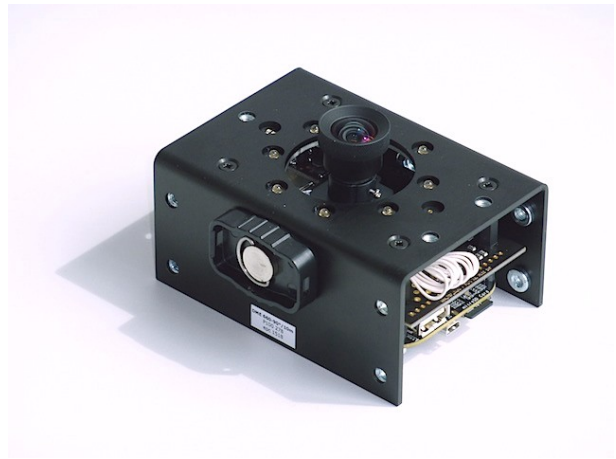

Figure 33: DME 635 with quick release fastener of the tripod

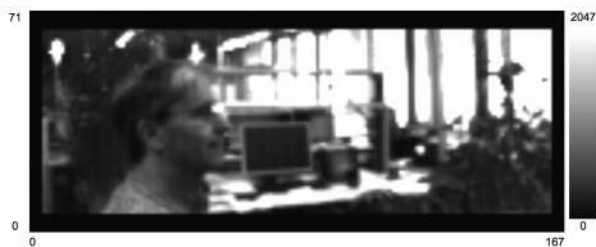

Figure 34: GUI - b&w picture

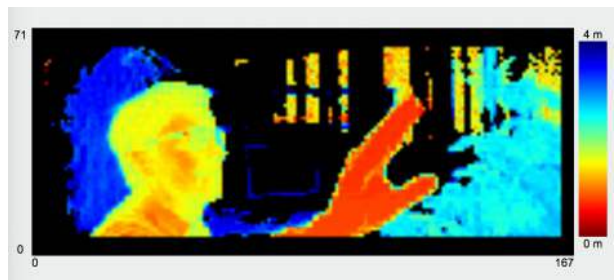

Figure 35: GUI - 3D TOF picture

13. Maintenance and disposal

13.1. Maintenance

The components of the device do not need regular maintenance. A functional check is recommended each time the device is taken into operation:

- Check the mounting position and the detection area of the sensor with respect to the operational conditions. Also check that there is no hazardous situation.
- From time to time, clean the lens with a soft towel and with a little soapy water to remove dust or dirt.

13.2. Disposal

Disposal should be done using the most up-to-date recycling technologies for electronic components according to the local regulations and laws. The design and manufacture of the kit's components are done in compliance with the RoHS legal regulations. Traces of dangerous materials may be found in the electronic components, but not in harmful quantities.

14. Addendum

14.1. Related documents

- Datasheet epc635, ESPROS Photonics Corp.
- BeagleBone Hardware Specs and Material, BeagleBone Black wiki
- BeagleBone Black System Reference Manual, BeagleBoard.org
- BeagleBone Black, Document No. 450-5500-001 (Schematics), BeagleBoard.org

14.2. Links

www.espros.com

www.beagleboard.org

www.pointcloud.org - Point Cloud Library (PCL)

www.pdal.io - Point Data Abstraction Library (PDAL)

www.opencv.org - OpenCV (OpenSource Computer Vision)

14.3. Licenses

We appreciate the use of the following open source or free software in our tools and respect the large amount of work the owners have done:

- **Putty**: <http://www.chiark.greenend.org.uk/~sgtatham/putty/licence.html>
Copyright (C) 1997-2015 Simon Tatham
- **Qt-4.8**: <http://www.gnu.org/licenses/old-licenses/lgpl-2.1.html>
Copyright (C) 2012 Nokia Corporation
- **Qwt-6.1**: <http://qwt.sourceforge.net/qwtlicense.html>
Copyright (C) 1997 Josef Wilgen & Copyright (C) 2002 Uwe Rathmann under **Qwt License, Version 1.0**
- **QwtPlot3D**: <http://qwtplot3d.sourceforge.net/web/navigation/license.txt>
Copyright (C) 2003-2005 Michael Bieber

All rights reserved by the owners.

THIS SOFTWARE IS PROVIDED BY THE COPYRIGHT HOLDERS AND CONTRIBUTORS "AS IS" AND ANY EXPRESS OR IMPLIED WARRANTIES, INCLUDING, BUT NOT LIMITED TO, THE IMPLIED WARRANTIES OF MERCHANTABILITY AND FITNESS FOR A PARTICULAR PURPOSE ARE DISCLAIMED. IN NO EVENT SHALL THE COPYRIGHT HOLDER OR CONTRIBUTORS BE LIABLE FOR ANY DIRECT, INDIRECT, INCIDENTAL, SPECIAL, EXEMPLARY, OR CONSEQUENTIAL DAMAGES (INCLUDING, BUT NOT LIMITED TO, PROCUREMENT OF SUBSTITUTE GOODS OR SERVICES; LOSS OF USE, DATA, OR PROFITS; OR BUSINESS INTERRUPTION) HOWEVER CAUSED AND ON ANY THEORY OF LIABILITY, WHETHER IN CONTRACT, STRICT LIABILITY, OR TORT (INCLUDING NEGLIGENCE OR OTHERWISE) ARISING IN ANY WAY OUT OF THE USE OF THIS SOFTWARE, EVEN IF ADVISED OF THE POSSIBILITY OF SUCH DAMAGE.

IMPORTANT NOTICE

ESPROS Photonics AG and its subsidiaries (epc) reserve the right to make corrections, modifications, enhancements, improvements, and other changes to its products and services at any time and to discontinue any product or service without notice. Customers should obtain the latest relevant information before placing orders and should verify that such information is current and complete. All products are sold subject to epc's terms and conditions of sale supplied at the time of order acknowledgment.

epc warrants performance of its hardware products to the specifications applicable at the time of sale in accordance with epc's standard warranty. Testing and other quality control techniques are used to the extent epc deems necessary to support this warranty. Except where mandated by government requirements, testing of all parameters of each product is not necessarily performed.

epc assumes no liability for applications assistance or customer product design. Customers are responsible for their products and applications using epc components. To minimize the risks associated with customer products and applications, customers should provide adequate design and operating safeguards.

epc does not warrant or represent that any license, either express or implied, is granted under any epc patent right, copyright, mask work right, or other epc intellectual property right relating to any combination, machine, or process in which epc products or services are used. Information published by epc regarding third-party products or services does not constitute a license from epc to use such products or services or a warranty or endorsement thereof. Use of such information may require a license from a third party under the patents or other intellectual property of the third party, or a license from epc under the patents or other intellectual property of epc.

Resale of epc products or services with statements different from or beyond the parameters stated by epc for that product or service voids all express and any implied warranties for the associated epc product or service. epc is not responsible or liable for any such statements.

epc products are not authorized for use in safety-critical applications (such as life support) where a failure of the epc product would reasonably be expected to cause severe personal injury or death, unless officers of the parties have executed an agreement specifically governing such use. Buyers represent that they have all necessary expertise in the safety and regulatory ramifications of their applications, and acknowledge and agree that they are solely responsible for all legal, regulatory and safety-related requirements concerning their products and any use of epc products in such safety-critical applications, notwithstanding any applications-related information or support that may be provided by epc. Further, Buyers must fully indemnify epc and its representatives against any damages arising out of the use of epc products in such safety-critical applications.

epc products are neither designed nor intended for use in military/aerospace applications or environments unless the epc products are specifically designated by epc as military-grade. Only products designated by epc as military-grade meet military specifications. Buyers acknowledge and agree that any such use of epc products which epc has not designated as military-grade is solely at the Buyer's risk, and that they are solely responsible for compliance with all legal and regulatory requirements in connection with such use.

epc products are neither designed nor intended for use in automotive applications or environments unless the specific epc products are designated by epc as compliant with ISO/TS 16949 requirements. Buyers acknowledge and agree that, if they use any non-designated products in automotive applications, epc will not be responsible for any failure to meet such requirements.