

THIS DRAWING IS UNPUBLISHED. RELEASED FOR PUBLICATION ,19 .
 © COPYRIGHT 19 BY AMP INCORPORATED. ALL RIGHTS RESERVED.

LOC	DIST	REVISIONS			
P	LTR	DESCRIPTION	DATE	DWN	APVD
CE	16	D	REV PER 0A00-0503-95	12-4-95	DDE SB

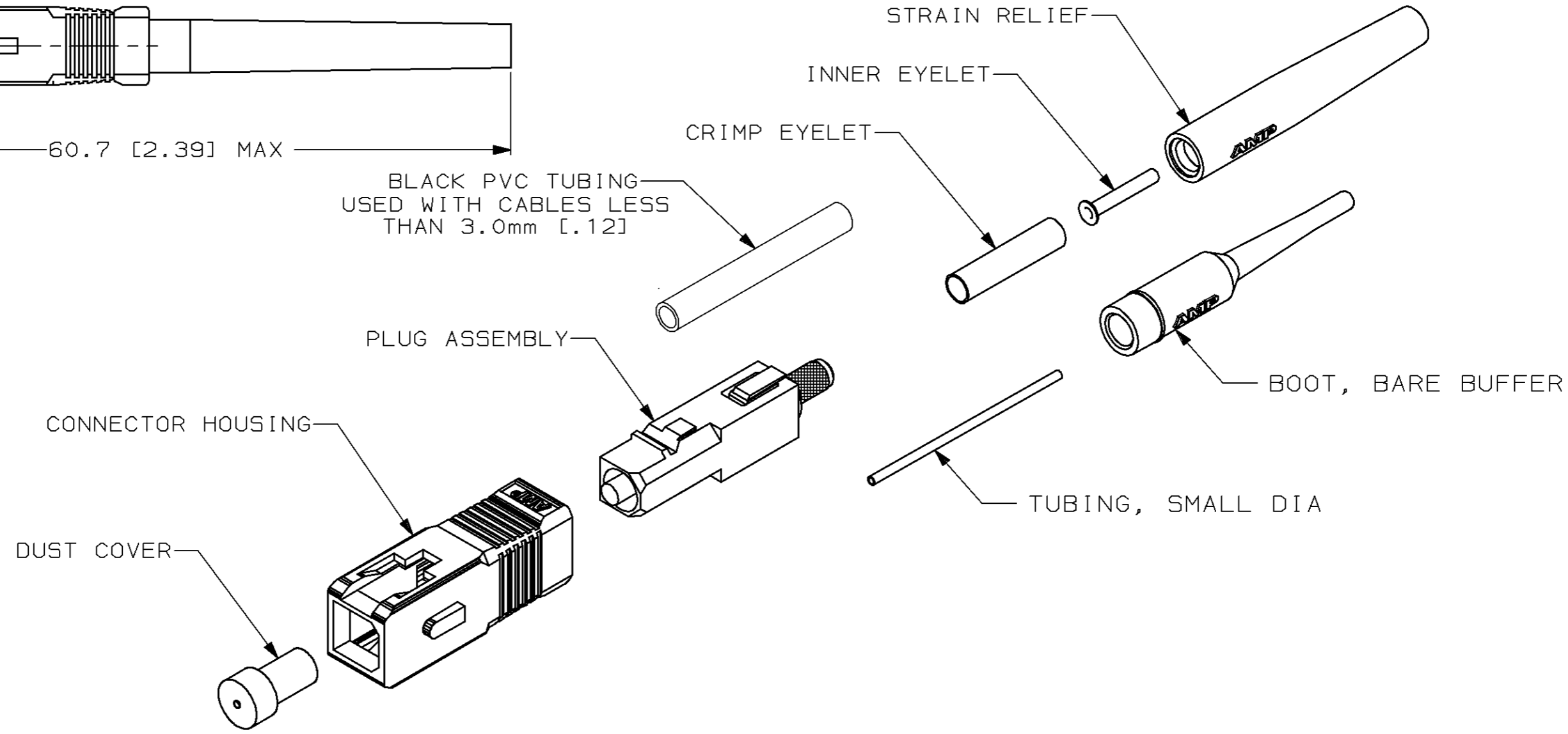
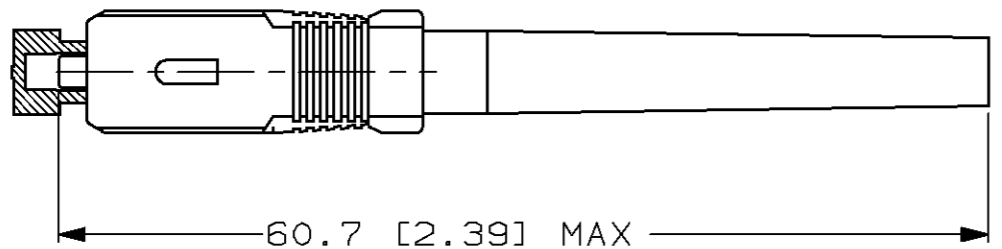

- 1 MATERIAL:
 PLUG BODY: THERMOPLASTIC, BEIGE
 CONNECTOR HOUSING: THERMOPLASTIC, BEIGE
 INTERNAL BODY: ZINC
 CRIMP EYELET: COPPER
 INNER EYELET: BRASS
 STRAIN RELIEF/BOOT: THERMOPLASTIC ELASTOMER, BEIGE
 CAPILLARY: ZrO₂
- 2 FINISH:
 INTERNAL BODY: ELECTROLESS NICKEL
 CRIMP EYELET: TIN

4. INSTRUCTION SHEET #408-4066

3. DIMENSIONS IN [] ARE IN INCHES.

<small>THIS DRAWING IS A CONTROLLED DOCUMENT FOR AMP INCORPORATED. IT IS SUBJECT TO CHANGE AND THE CONTROLLING ENGINEERING ORGANIZATION SHOULD BE CONTACTED FOR THE LATEST REVISION.</small>		DWN D ERDMAN 6-27-94 CHK J MCKEE 6-27-94 APVD B EDWARDS 6-27-94 PRODUCT SPEC - APPLICATION SPEC - WEIGHT - CUSTOMER DRAWING
DIMENSIONS: mm 	TOLERANCES UNLESS OTHERWISE SPECIFIED: 0 PLC ±- 1 PLC ±- 2 PLC ±0.13 [.005] 3 PLC ±- 4 PLC ±- ANGLES ±1° FINISH -	NAME AMP AMP Incorporated Harrisburg, PA 17105-3608 KIT, CONNECTOR, AMP LightCrimp SC SIMPLEX, MULTIMODE SIZE A3 CAGE CODE 00779 DRAWING NO C-503692 SCALE 2:1 SHEET 1 OF 1 REV D

125±2µm	503692-1
FIBER SIZE	PART NO
AMP AMP Incorporated Harrisburg, PA 17105-3608	
KIT, CONNECTOR, AMP LightCrimp SC SIMPLEX, MULTIMODE	
SIZE	DRAWING NO
A3	C-503692
CAGE CODE	SHEET
00779	1 OF 1
SCALE	REV
2:1	D