

THIS DRAWING IS UNPUBLISHED. RELEASED FOR PUBLICATION 20  
 © COPYRIGHT 20 BY - ALL RIGHTS RESERVED.

REVISIONS				
P	LTR	DESCRIPTION	DATE	APVD
A		INITIAL RELEASE	02FEB2016	JY SH
A1		REVISED PER ECN-22-163746	11JUL2022	IT SZ

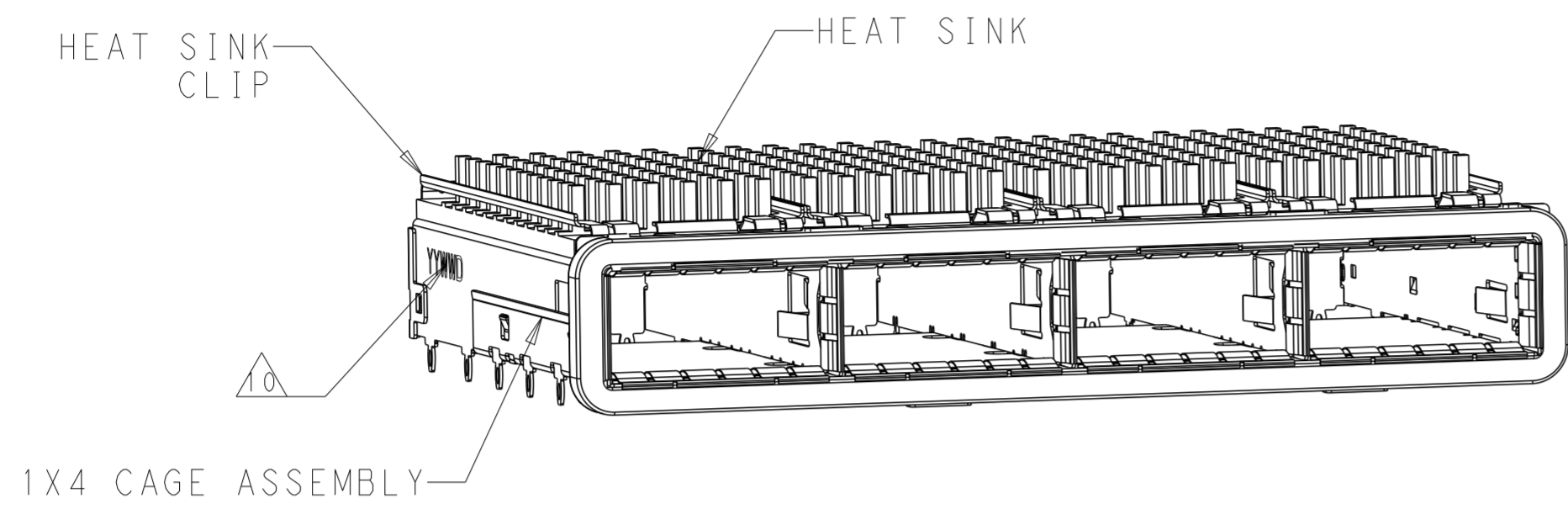

- COMPONENTS  
 CAGE ASSEMBLY: NICKEL-SILVER ALLOY  
 HEAT SINK: ALUMINUM/BLACK ANODIZE  
 HEAT SINK CLIP: STAINLESS STEEL  
 EMI SPRING: COPPER ALLOY/NICKEL PLATE  
 EMI GASKET: PLATED FILLED SILICONE
- REFERENCE APPLICATION SPECIFICATION 114-32023 FOR RECOMMENDED DRILL HOLE DIAMETER AND PLATING THICKNESS
- DATUM AND BASIC DIMENSION ESTABLISHED BY CUSTOMER
- DIMENSION APPLIES WITH MODULE INSERTED IN CAGE
- HEAT SINKS, HEAT SINK CLIPS AND LIGHT PIPES ARE SHIPPED ASSEMBLED ON CAGE
- MINIMUM PC BOARD THICKNESS: SINGLE SIDED: 1.57 MIN  
 DOUBLE SIDED: 3.00 MIN
- DATUM **-A-** IS TOP SURFACE OF THE HOST BOARD.
- THESE HOLES ARE OPTIONAL WHEN THE REAR PINS ARE REMOVED.
- MATES WITH QSFP28 MSA COMPATIBLE TRANSCEIVER.
- DATE CODE (YYWWD) MARKED APPROXIMATELY AS SHOWN.

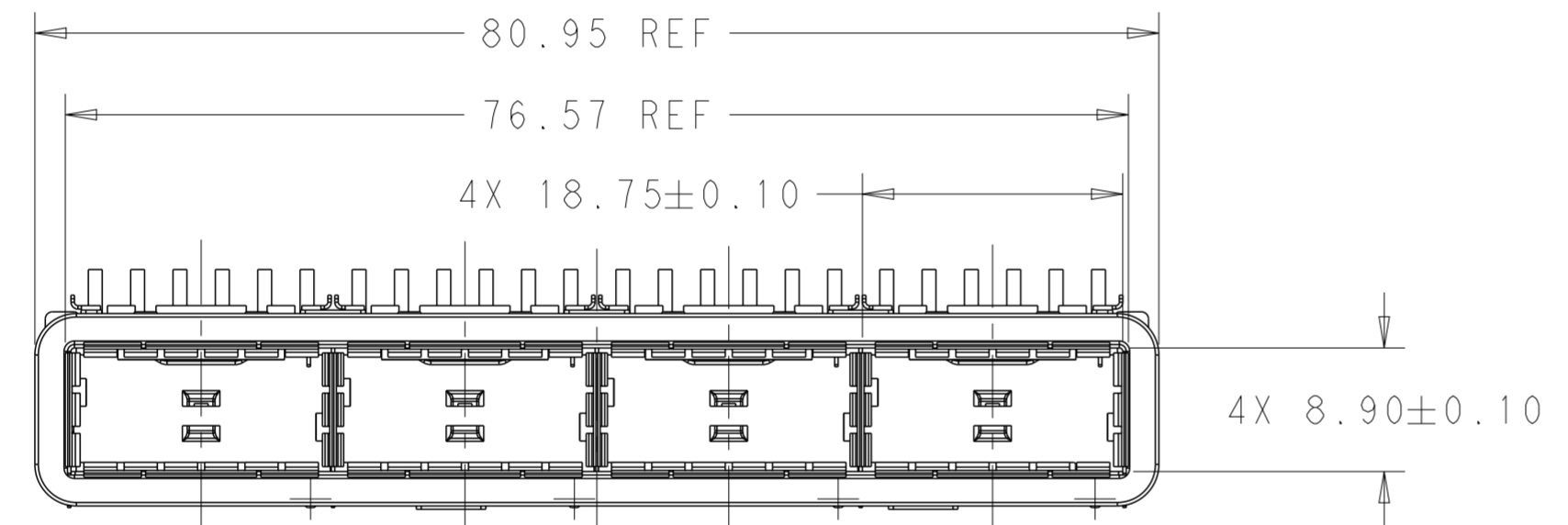

SCALE 2:1

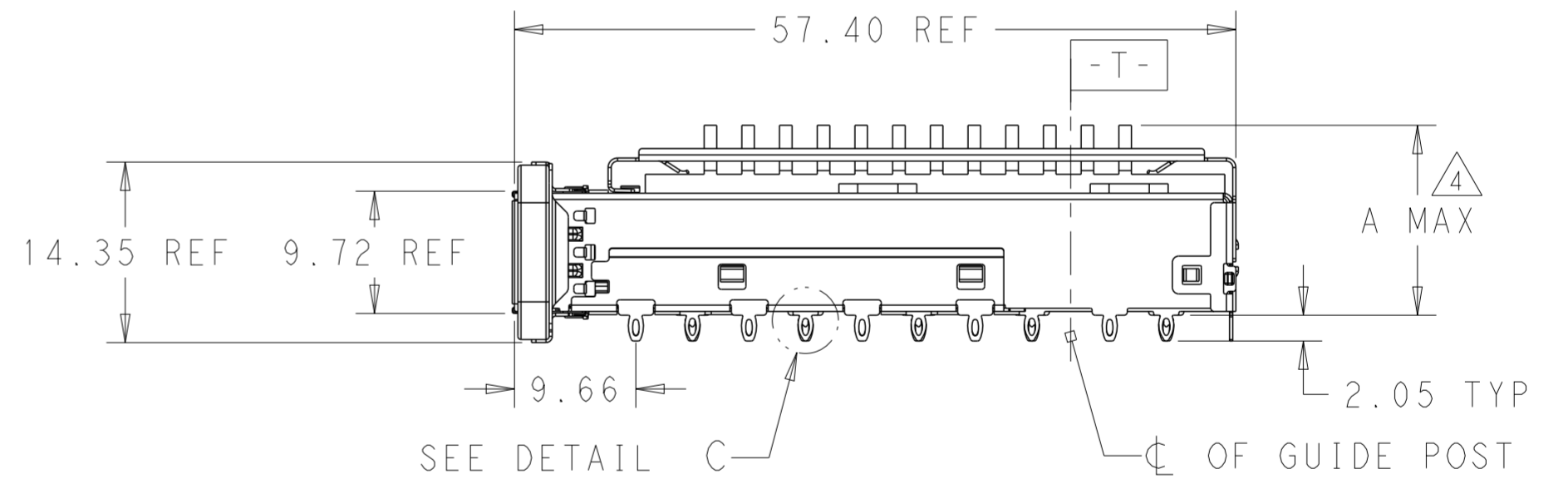

SEE DETAIL C

23.0	WITHOUT	NETWORKING	2170783-6
16.0	WITHOUT	SAN	2170783-5
13.7	WITHOUT	PCI	2170783-4
23.0	WITH	NETWORKING	2170783-3
16.0	WITH	SAN	2170783-2
13.7	WITH	PCI	2170783-1
DIM A	REAR PINS OPTIONAL	APPLICATION	PART NUMBER

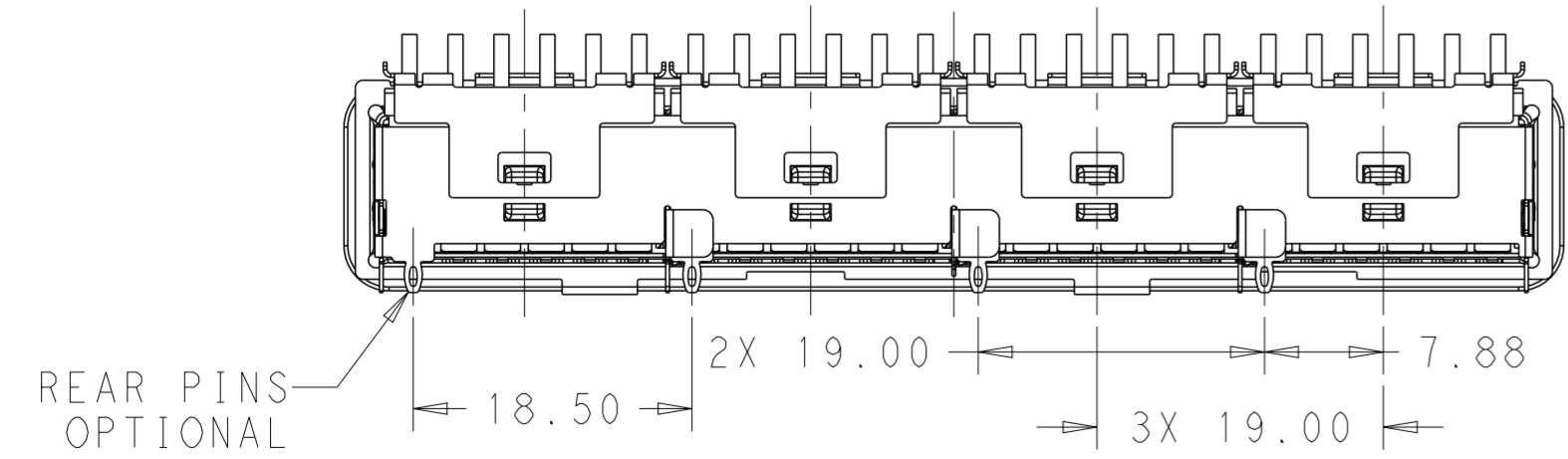

BACK VIEW SCALE 2:1

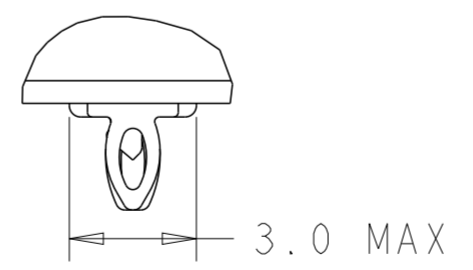

DETAIL C SCALE 6:1

THIS DRAWING IS A CONTROLLED DOCUMENT. DWN 08JUN2014  
 JASON YANG  
 CHK 02FEB2016  
 SEAN HAN

APVD -

PRODUCT SPEC 108-19428  
 APPLICATION SPEC 114-32023

NAME RECEPTACLE CAGE ASSEMBLY 1X4, QSFP28 WITH HEAT SINKS THRU BEZEL, GASKET

SIZE A2 CAGE CODE 00779 DRAWING NO C-2170783

MATERIAL SEE NOTES TOLERANCES UNLESS OTHERWISE SPECIFIED: 0 PLC ±, 1 PLC ±0.25, 2 PLC ±0.2, 3 PLC ±, 4 PLC ±, ANGLES ±, FINISH SEE NOTES

CUSTOMER DRAWING SCALE 3:1 SHEET 1 OF 5 REV A1

STE TE Connectivity

THIS DRAWING IS UNPUBLISHED. RELEASED FOR PUBLICATION 20  
 © COPYRIGHT 20 BY - ALL RIGHTS RESERVED.

REVISIONS				
P	LTR	DESCRIPTION	DATE	APVD
-	-	SEE SHEET 1	-	-

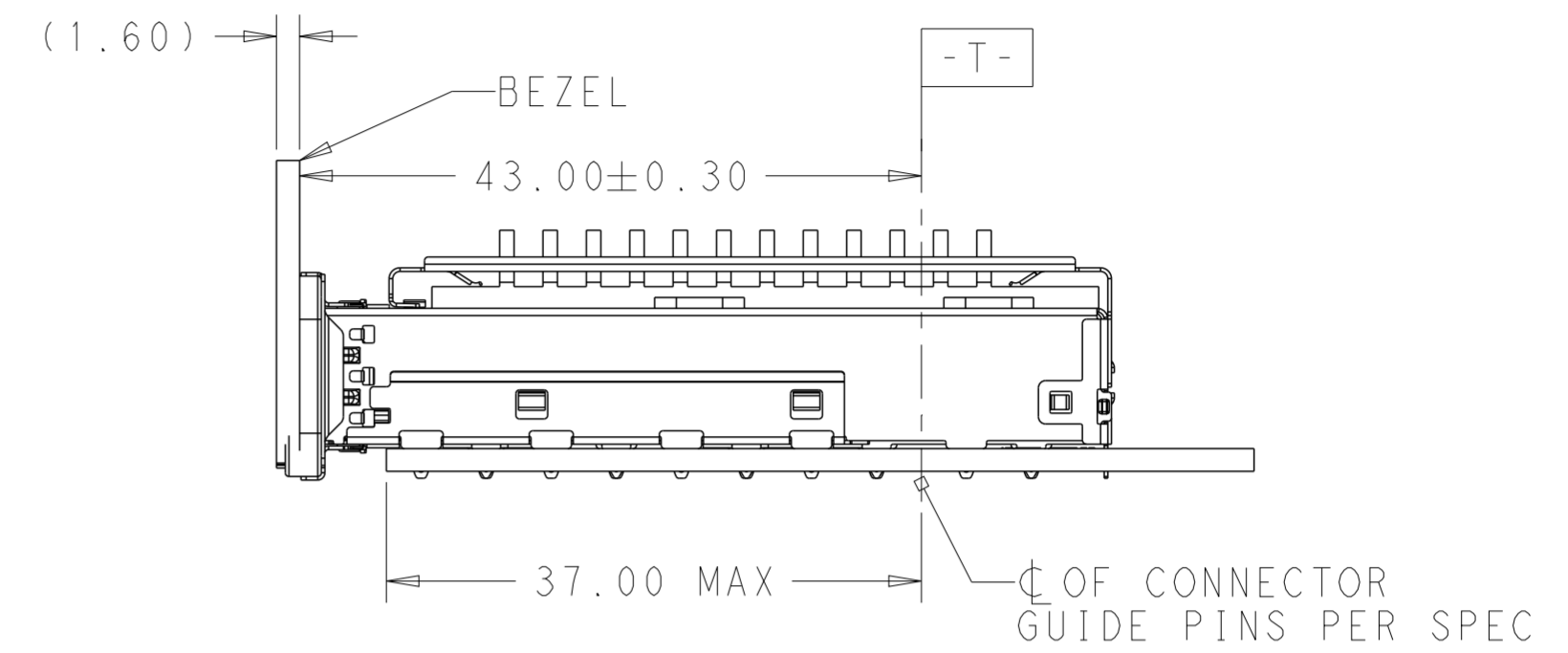
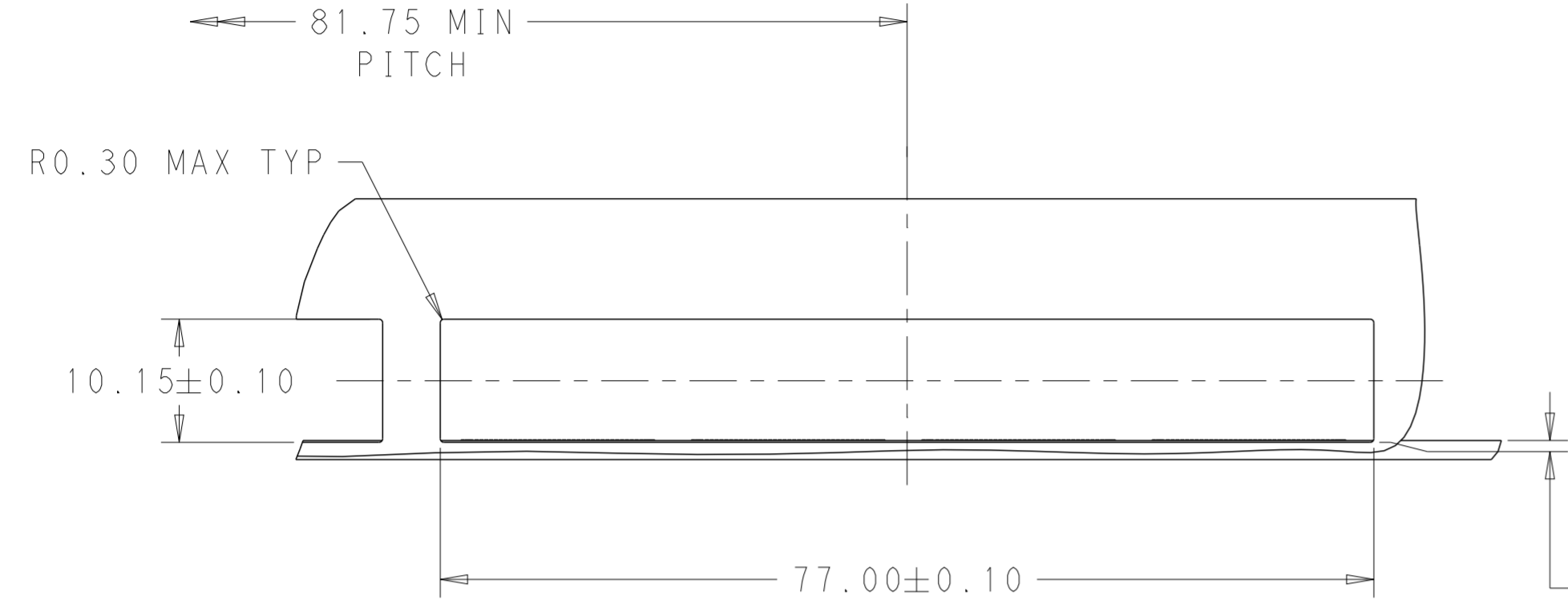

SINGLE SIDE MOUNTING  
SCALE 2:1

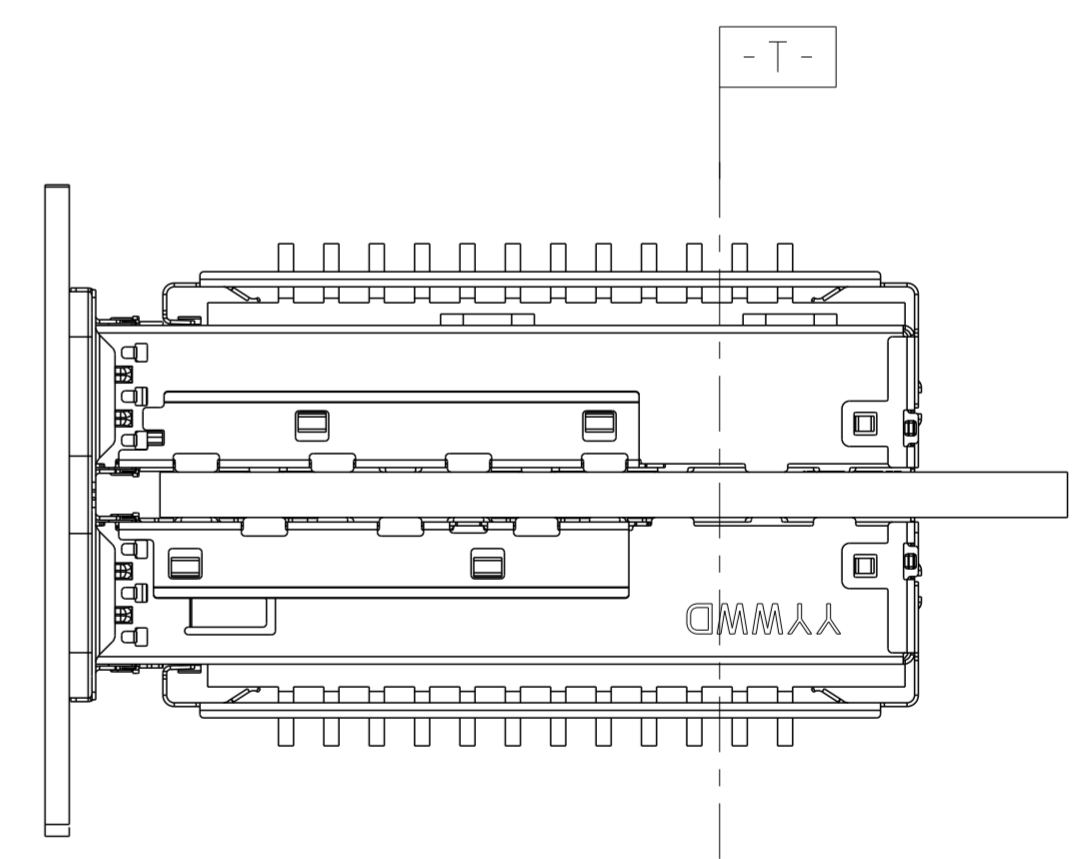
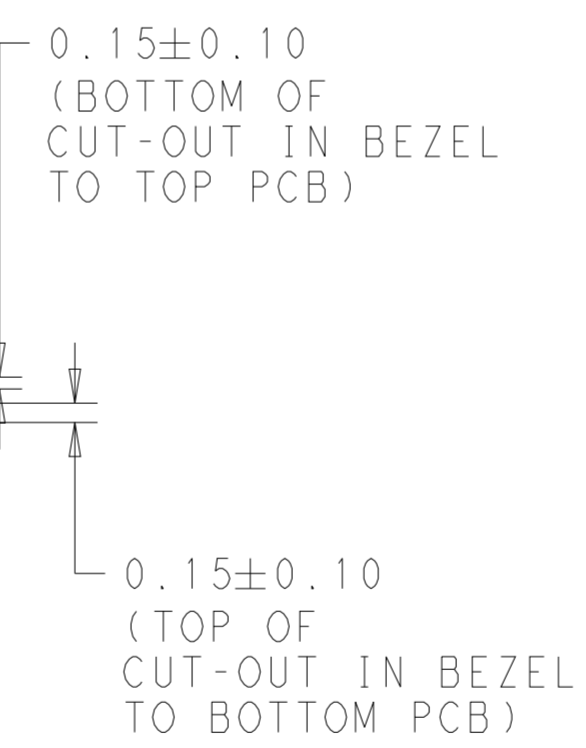
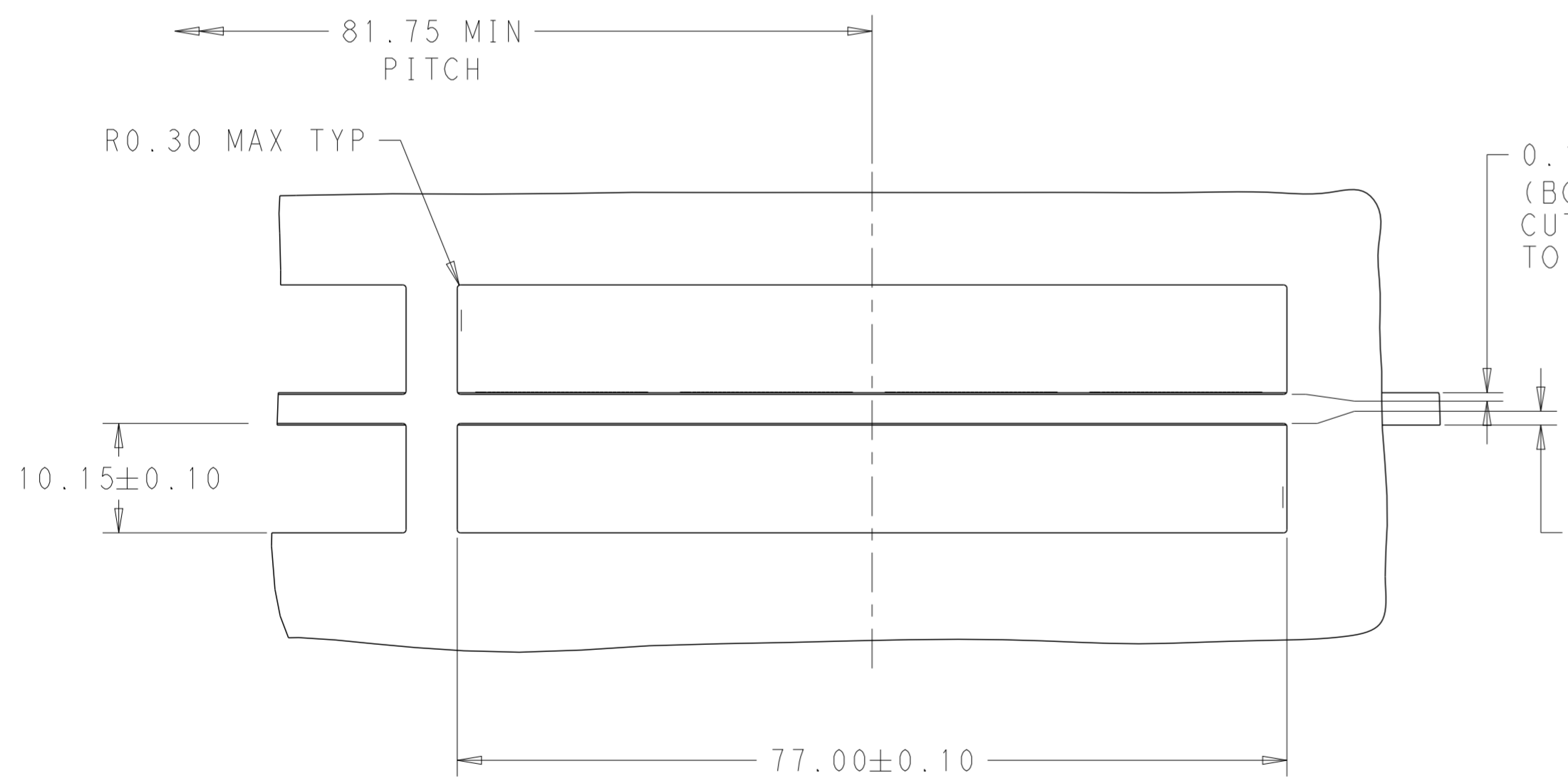

BELLY TO BELLY MOUNTING  
SCALE 2:1

THIS DRAWING IS A CONTROLLED DOCUMENT.		DWN 08JUN2014 JASON YANG	 TE Connectivity	
DIMENSIONS: mm		CHK 02FEB2016 SEAN HAN		
TOLERANCES UNLESS OTHERWISE SPECIFIED:		APVD -	PRODUCT SPEC 108-19428	RESTRICTED TO
0 PLC ±- 1 PLC ±0.25 2 PLC ±0.2 3 PLC ±- 4 PLC ±- ANGLES ±- FINISH ±-		APPLICATION SPEC 114-32023	SIZE A200779	DRAWING NO C-2170783
MATERIAL SEE NOTES		WEIGHT -	CUSTOMER DRAWING	SCALE 3:1 SHEET 2 OF 5 REV A1

THIS DRAWING IS UNPUBLISHED. RELEASED FOR PUBLICATION 20  
 © COPYRIGHT 20 BY - ALL RIGHTS RESERVED.

REVISIONS				
P	LTR	DESCRIPTION	DATE	APVD
-	-	SEE SHEET 1	-	-

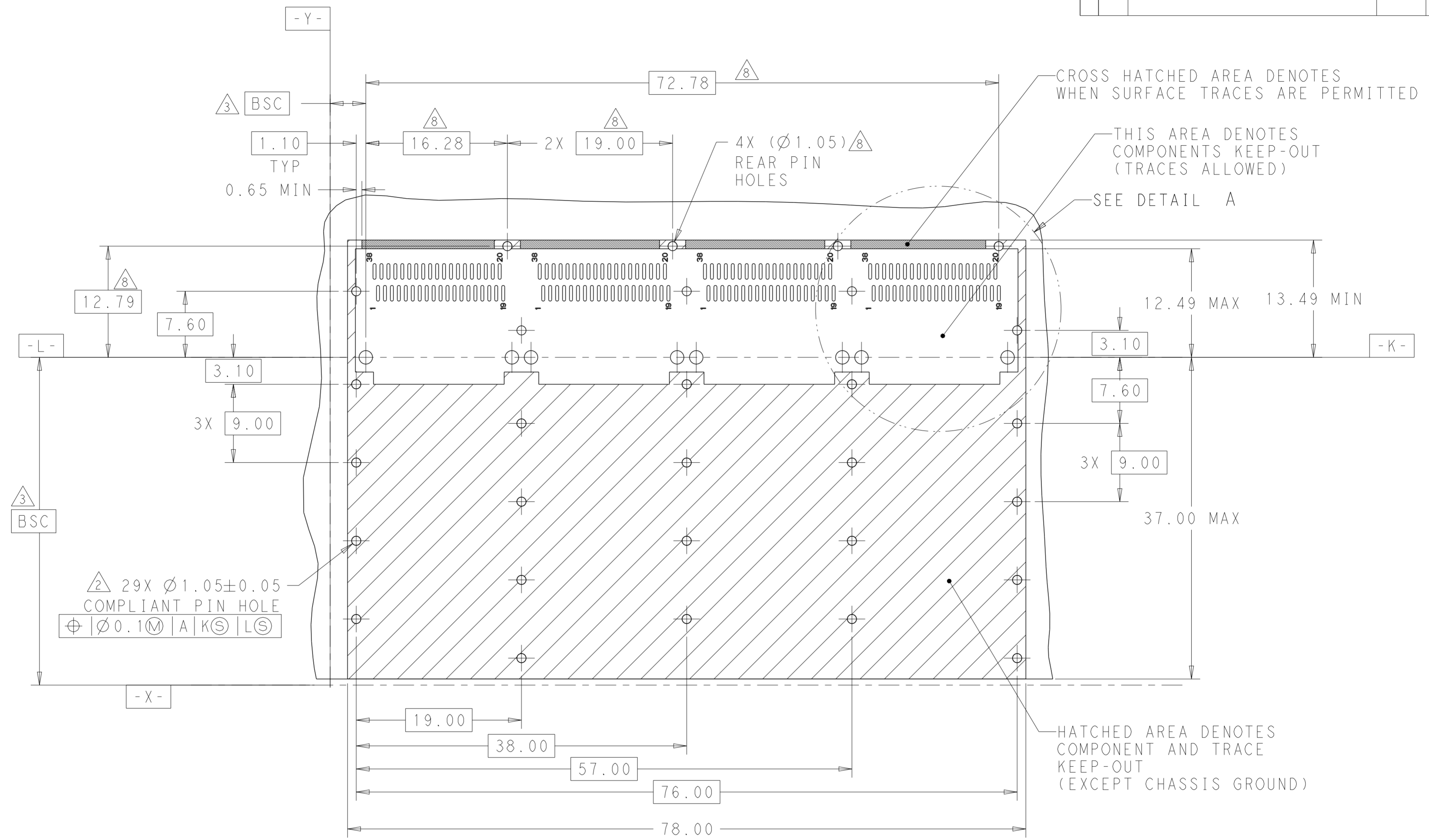

RECOMMENDED PCB LAYOUT  
 SINGLE TYPE  
 PCB TOLERANCE: ±0.05  
 SCALE 3:1

THIS DRAWING IS A CONTROLLED DOCUMENT.		DWN JASON YANG 08JUN2014	TE Connectivity	
		CHK SEAN HAN 02FEB2016		
DIMENSIONS: mm 		TOLERANCES UNLESS OTHERWISE SPECIFIED: 0 PLC ± 1 PLC ±0.25 2 PLC ±0.2 3 PLC ± 4 PLC ± ANGLES ± FINISH SEE NOTES		NAME RECEPTACLE CAGE ASSEMBLY 1X4, QSFP28 WITH HEAT SINKS THRU BEZEL, GASKET
MATERIAL SEE NOTES		PRODUCT SPEC 108-19428 APPLICATION SPEC 114-32023 WEIGHT -	SIZE A200779	DRAWING NO C-2170783 RESTRICTED TO -
		CUSTOMER DRAWING		SCALE 3:1 SHEET 3 OF 5 REV A1

REVISIONS				
P	LTR	DESCRIPTION	DATE	APVD
-	-	SEE SHEET 1	-	-

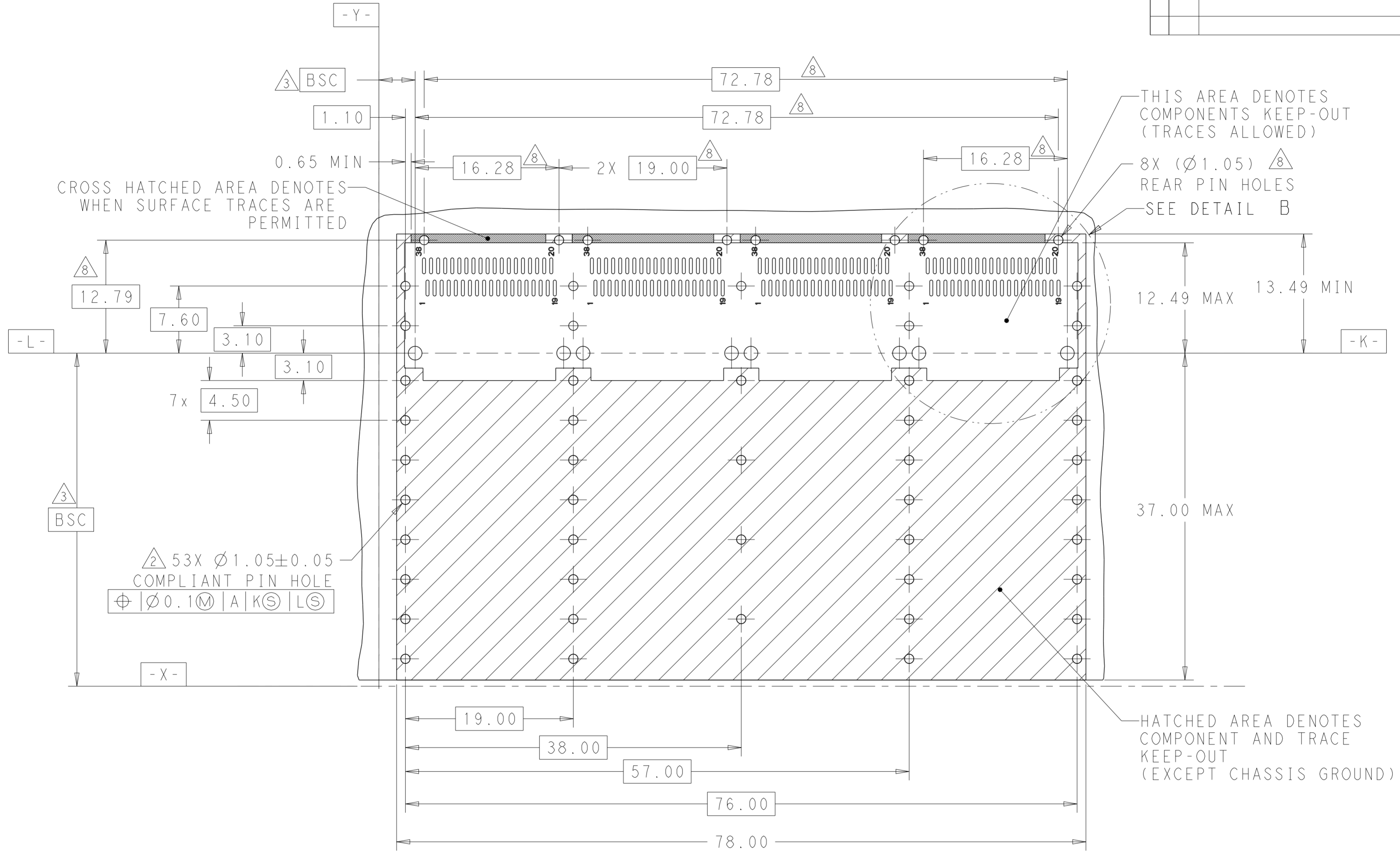

RECOMMENDED PCB LAYOUT  
 BELLY TO BELLY TYPE  
 PCB TOLERANCE: ±0.05  
 SCALE 3:1

THIS DRAWING IS A CONTROLLED DOCUMENT.		DWN JASON YANG 08JUN2014	TE Connectivity	
		CHK SEAN HAN 02FEB2016		
DIMENSIONS: mm		APVD -		NAME RECEPTACLE CAGE ASSEMBLY 1X4, QSFP28 WITH HEAT SINKS THRU BEZEL, GASKET
TOLERANCES UNLESS OTHERWISE SPECIFIED: 0 PLC ±- 1 PLC ±0.25 2 PLC ±0.2 3 PLC ±- 4 PLC ±- ANGLES ±- FINISH		PRODUCT SPEC 108-19428		SIZE A2
MATERIAL SEE NOTES		APPLICATION SPEC 114-32023		CAGE CODE 00779
		WEIGHT -		DRAWING NO C-2170783
		CUSTOMER DRAWING		RESTRICTED TO -
		SCALE 3:1		SHEET 4 OF 5
				REV A1

THIS DRAWING IS UNPUBLISHED. RELEASED FOR PUBLICATION 20  
 © COPYRIGHT 20 BY - ALL RIGHTS RESERVED.

REVISIONS				
P	LTR	DESCRIPTION	DATE	APVD
-	-	SEE SHEET 1	-	-

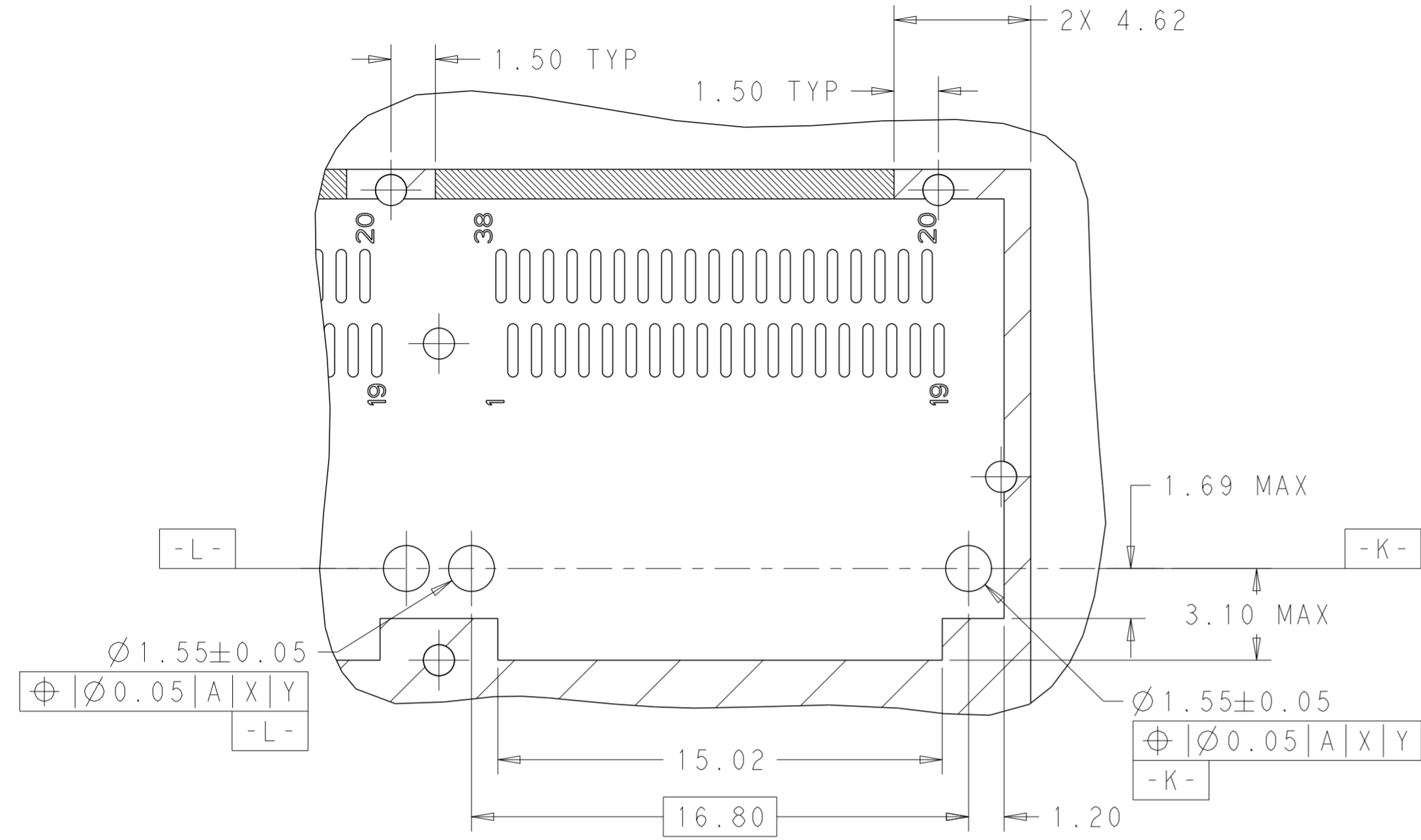

DETAIL A  
SCALE 6:1

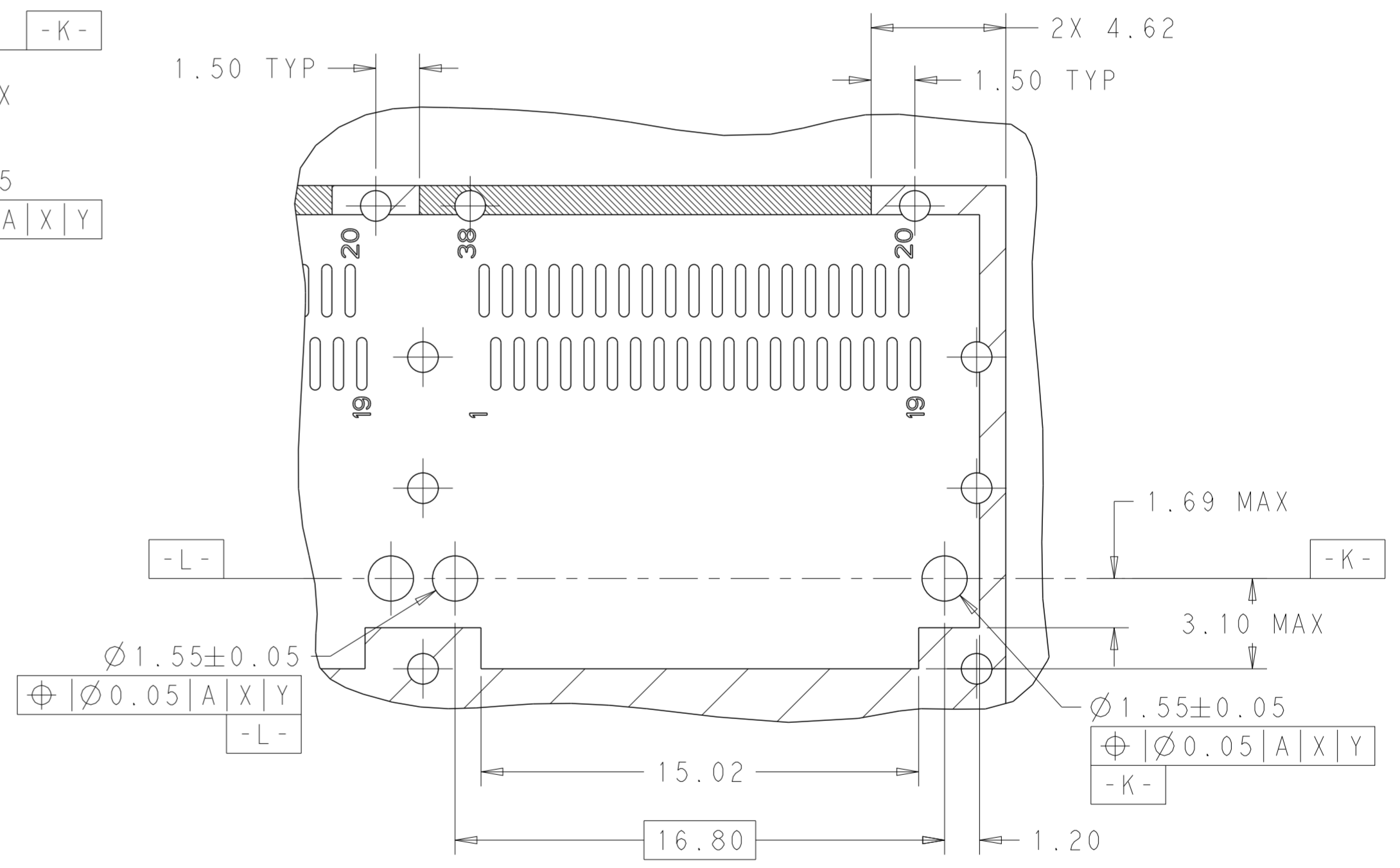

DETAIL B  
SCALE 6:1

THIS DRAWING IS A CONTROLLED DOCUMENT.		DWN JASON YANG 08JUN2014	 TE Connectivity	
		CHK SEAN HAN 02FEB2016		
DIMENSIONS:	TOLERANCES UNLESS OTHERWISE SPECIFIED:	APVD -	NAME RECEPTACLE CAGE ASSEMBLY 1X4, QSFP28 WITH HEAT SINKS THRU BEZEL, GASKET	
mm	0 PLC ± 1 PLC ±0.25 2 PLC ±0.2 3 PLC ± 4 PLC ±	PRODUCT SPEC 108-19428	SIZE A200779	
MATERIAL SEE NOTES	FINISH SEE NOTES	APPLICATION SPEC 114-32023	CAGE CODE C-2170783	DRAWING NO -
		WEIGHT -	RESTRICTED TO -	SCALE 3:1
		CUSTOMER DRAWING	SHEET 5 OF 5	REV A1