

Dual Channel Differential DSL Line Driver

The ISL1533 is a dual channel differential amplifier designed for driving full rate ADSL2+ signals at very low power dissipation. The high drive capability of 450mA makes this driver ideal for DMT designs. It contains two pairs of wideband, high-voltage, current mode feedback amplifiers designed on Intersil's HS30 Bipolar SOI process for low power consumption in DSL systems. This process also provides for very rugged protection against lightning induced surges on the line.

These drivers achieve an MTPR distortion measurement of better than 70dB, while consuming typically 5mA per DSL channel of total supply current in 1/2 I_S mode. This supply current can be set using a resistor on the I_{ADJ} pin. Two other pins (C₀ and C₁) can also be used to adjust supply current to one of four preset modes (full-I_S, 3/4-I_S, 1/2-I_S, and full power-down). The ISL1533 integrates 50k pull-up resistors on C₀ and C₁ pins to initially disable the device.

The ISL1533 operates on ±5V to ±15V supplies and retains its bandwidth and linearity over the complete supply range.

The device is supplied in a thermally-enhanced 20 Ld HTSSOP and the small footprint (4mmx5mm) 24 Ld QFN packages. The ISL1533 is specified for operation over the full -40°C to +85°C temperature range.

Features

- 450mA output drive capability
- 44.4V_{P-P} differential output drive into 100Ω
- ±5V to ±15V supply operation
- MTPR of -70dB
- Operates down to supply current of 4mA per port
- Current control pins
- Channel separation
 - 80dB @ 500kHz
- High ESD protection from lightning induced transients
- Pb-free (RoHS compliant)
- Surpasses GR1089, ANSI, and ETSI requirements

Applications

- Dual port ADSL2+ line drivers
- HDSL line drivers

Get Full Datasheet

Pinouts

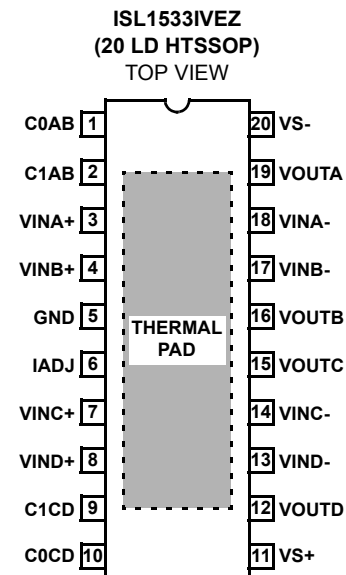
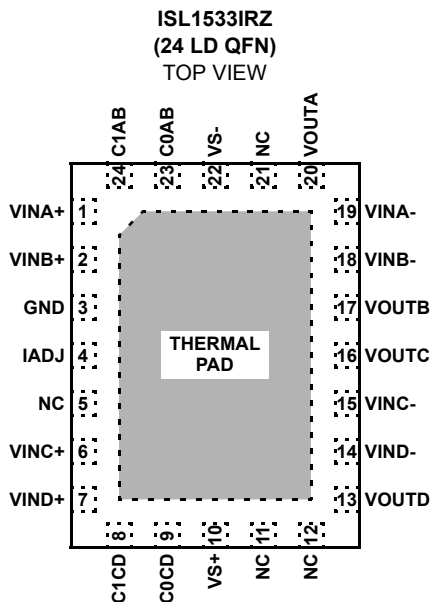

All Intersil U.S. products are manufactured, assembled and tested utilizing ISO9000 quality systems.
Intersil Corporation's quality certifications can be viewed at www.intersil.com/design/quality

Intersil products are sold by description only. Intersil Corporation reserves the right to make changes in circuit design, software and/or specifications at any time without notice. Accordingly, the reader is cautioned to verify that data sheets are current before placing orders. Information furnished by Intersil is believed to be accurate and reliable. However, no responsibility is assumed by Intersil or its subsidiaries for its use; nor for any infringements of patents or other rights of third parties which may result from its use. No license is granted by implication or otherwise under any patent or patent rights of Intersil or its subsidiaries.

For information regarding Intersil Corporation and its products, see www.intersil.com