

P L Y A C E N E C A P A C I T O R S

PAS(Polyacenic Semiconductor), which has been originally developed by Shoei Electronics is a kind of conductive polymers synthesized through pyrolytic treatment of phenolic resin. PAS capacitors, in which PAS is employed for both positive and negative electrodes, show extremely high performance.

Features

● High capacity / High reliability

PAS can store a large number of ions into its amorphous structure (doping), therefore PAS capacitor has much larger capacity than conventional electric double layer capacitor. In addition, PAS is extremely stable material and PAS capacitor shows excellent performance of cycle life and durability to overcharge and overdischarge.

● RoHS / WEEE compliance

PAS capacitors are RoHS and WEEE compliant products and have no recycling and collection duty that is required in lithium ion battery's case.

● The world's smallest capacitor

"PAS311 series" is the world's smallest coin shaped capacitors, which size is diameter 3.8mm × height 1.1mm. This smallest product was carried out by developing electrode materials, sealing technology and introducing special processed heat resistance gasket.

Molecular structure of PAS

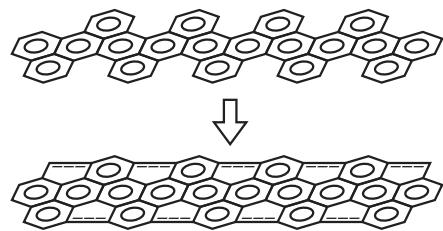

SEM image of PAS

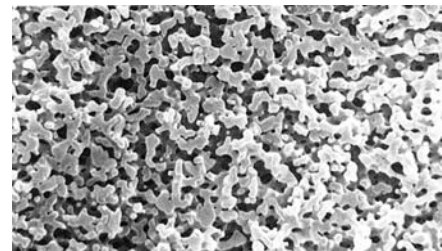

Coin type

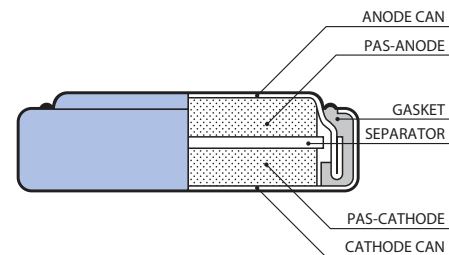

Line-up

	Part Number	Max. usable voltage (V)	Capacitance (F)	Capacity * (μAh)	Cell diameter (mm)	Cell height (mm)
SR series	PAS311SR-VA6R	2.6	0.03	10	3.8	1.1
HR series	PAS311HR-VA6R	3.3	0.03	10	3.8	1.1
	PAS409HR-VE5R		0.03	12	4.8	0.9
	PAS414HR-VG1		0.06	20	4.8	1.4
	PAS414HR-VA5R					
	PAS414HR-VE5R					

*SR series: Capacity is measured from 2.5V to 1.5V

HR series: Capacity is measured from 3.3V to 2.0V (approximately doubled capacity can be obtained from 3.3V to 1.0V)

Characteristics (Typical of PAS414HR)

Charging characteristics (Constant R)

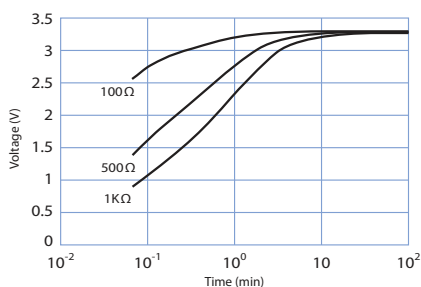

Discharging characteristics (Constant R)

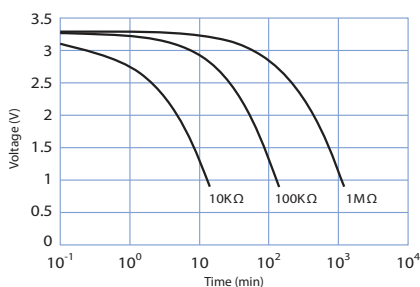

Temperature characteristics

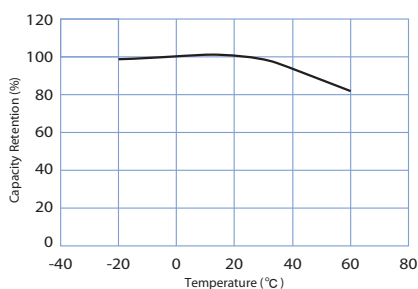

High temperature load characteristics

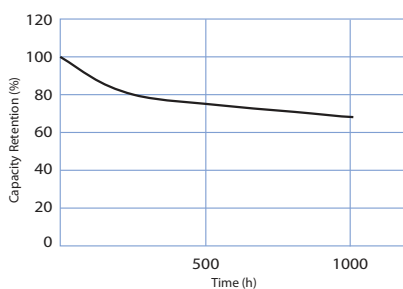

Cycle characteristics

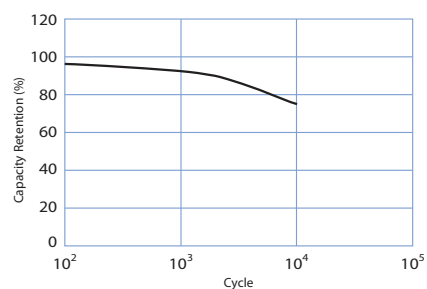

Examples of terminal

Solder plating area
(Measure: mm)

409-VE5R type

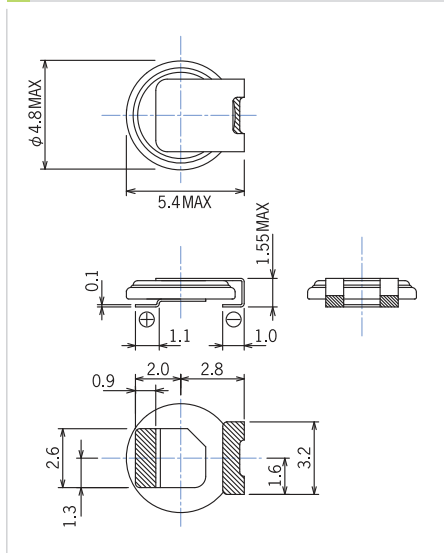

414-VA5R type

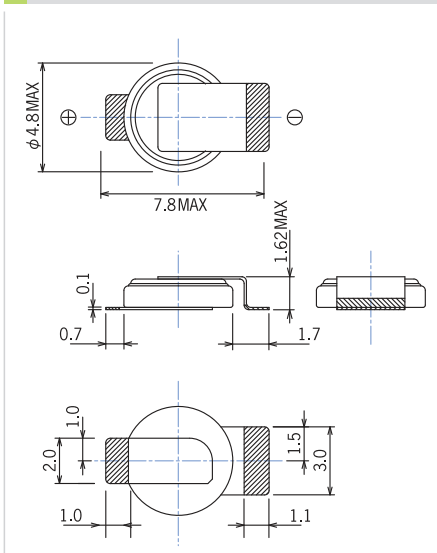

414-VE5R type

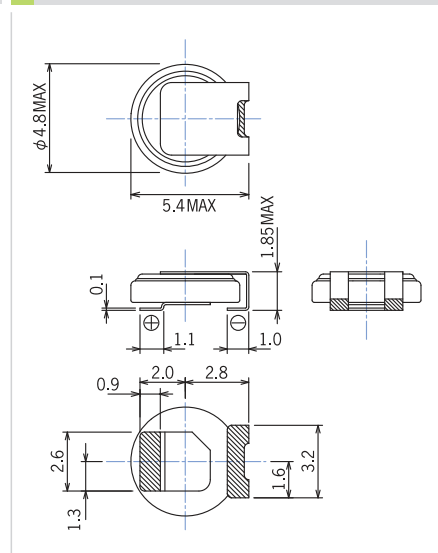

*Contact us for other terminals.

Shoei Electronics Co., Ltd. < A member of TAIYO YUDEN Co.,Ltd. >

Headquarters:
587-3 Sumiyoshi, Ueda-shi,
Nagano, 386-0002 Japan

Sales Office:
Kawaramachi KT Bldg. 7F
3-3-7, Kawaramachi, Chuo-ku, Osaka, 541-0048 Japan
TEL: +81-6-6231-3337 / FAX: +81-6-6231-3339

URL: <http://www.shoei-electro.com/>

Characteristics (Typical of PAS311SR)

Charging characteristics (Constant R)

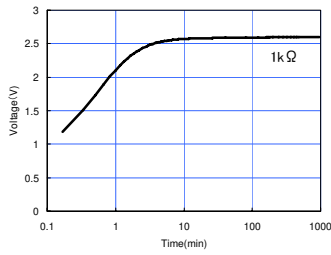

Discharge Characteristics (Constant Current)

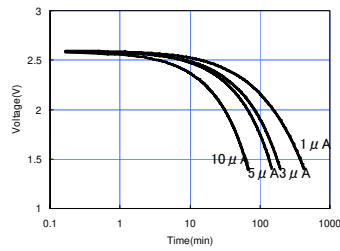

Temperature characteristics

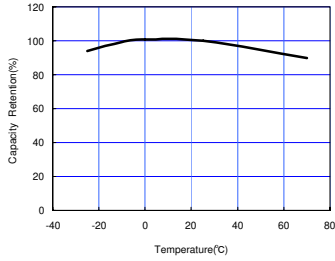

High temperature load characteristics

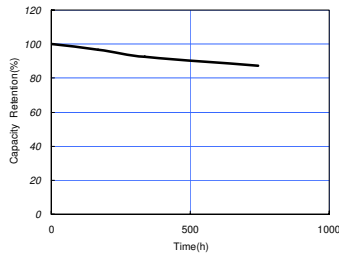

Cycle characteristics

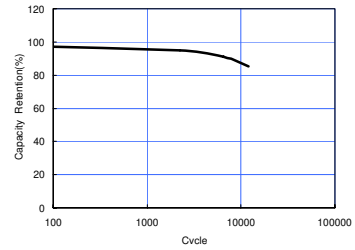

Characteristics (Typical of PAS311HR)

Charging characteristics (Constant R)

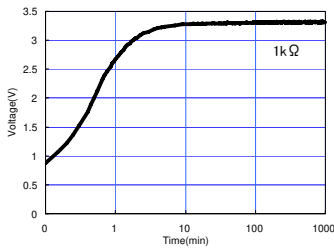

Discharge Characteristics (Constant Current)

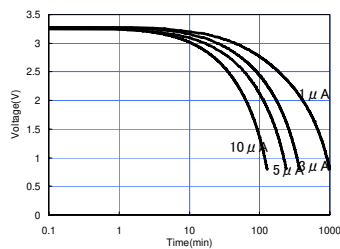

Temperature characteristics

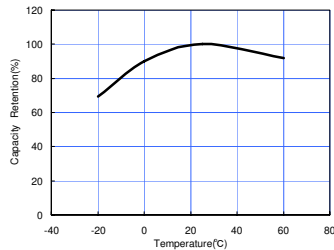

High temperature load characteristics

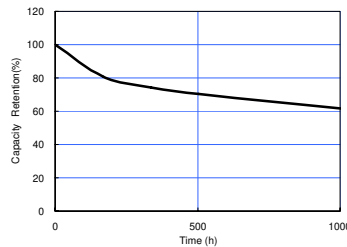

Cycle characteristics

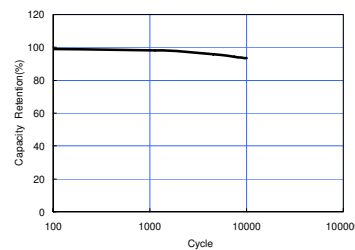

Examples of terminal

311-VA6R type

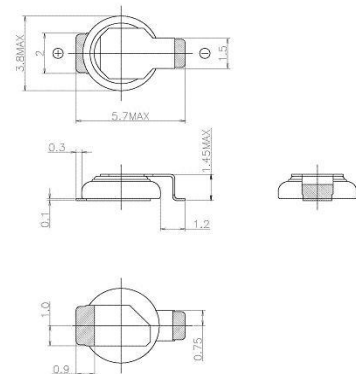

Solder plating area
(Measure:mm)

Shoel Electronics Co.,Ltd. <A member of TAIYO YUDEN Co.,Ltd.>

Headquarters: 587-3 Sumiyoshi, Ueda-shi, Nagano, 386-0002 Japan

Sales Office : Kawaramachi KT Bldg.7F, 3-3-7, Kawaramachi, Chuo-ku, Osaka, 541-0048 Japan TEL: +81-6-6231-3337 FAX: +81-6-6231-3339

URL : <http://www.shoel-electro.com/>

PAS

Examples of terminal

POLYACENE CAPACITORS

 Solder plating area
(Measure: mm)

414-VE5R type

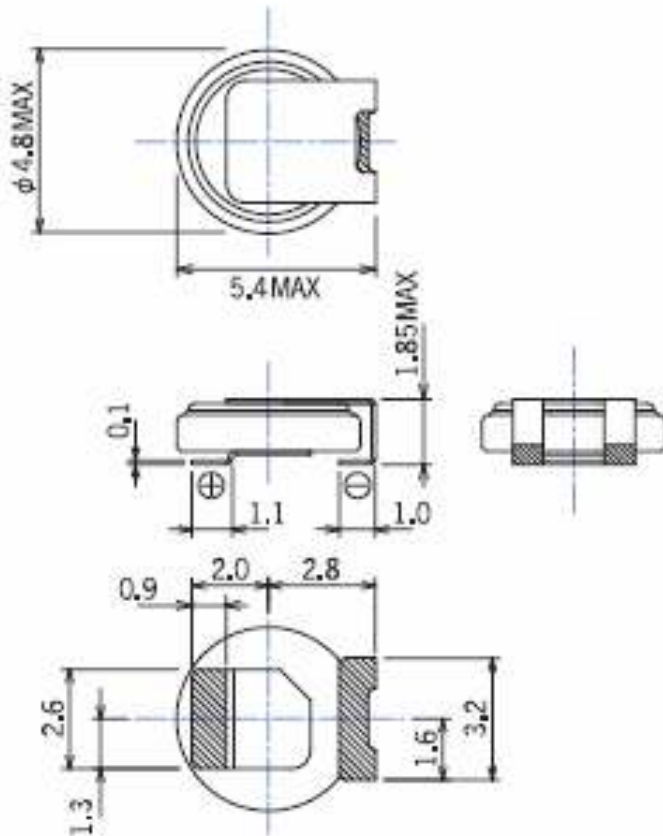

414-VG1 type

