

DETAIL B

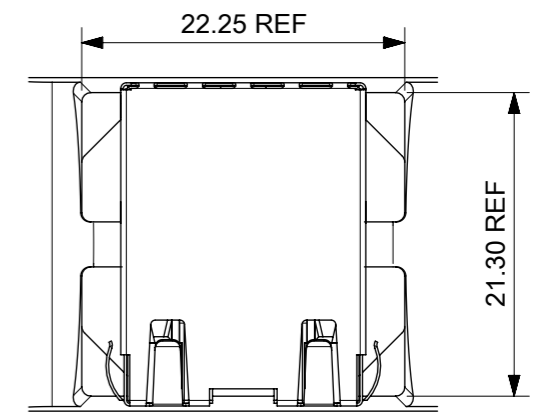

DETAIL C
SCALE 2:1

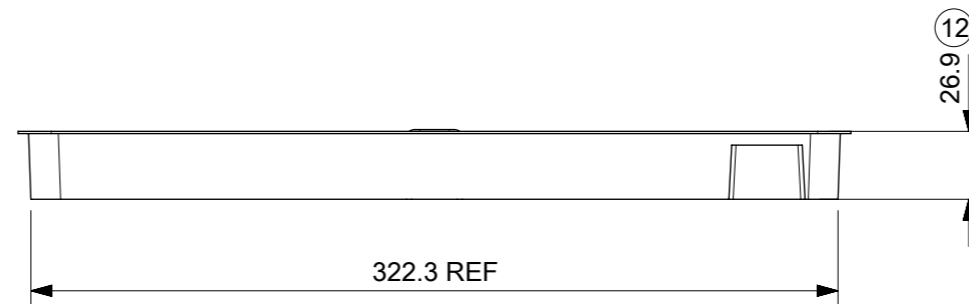
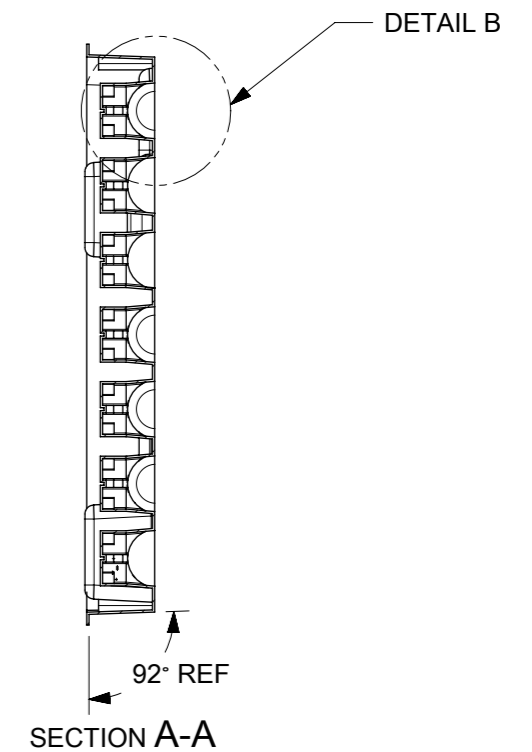
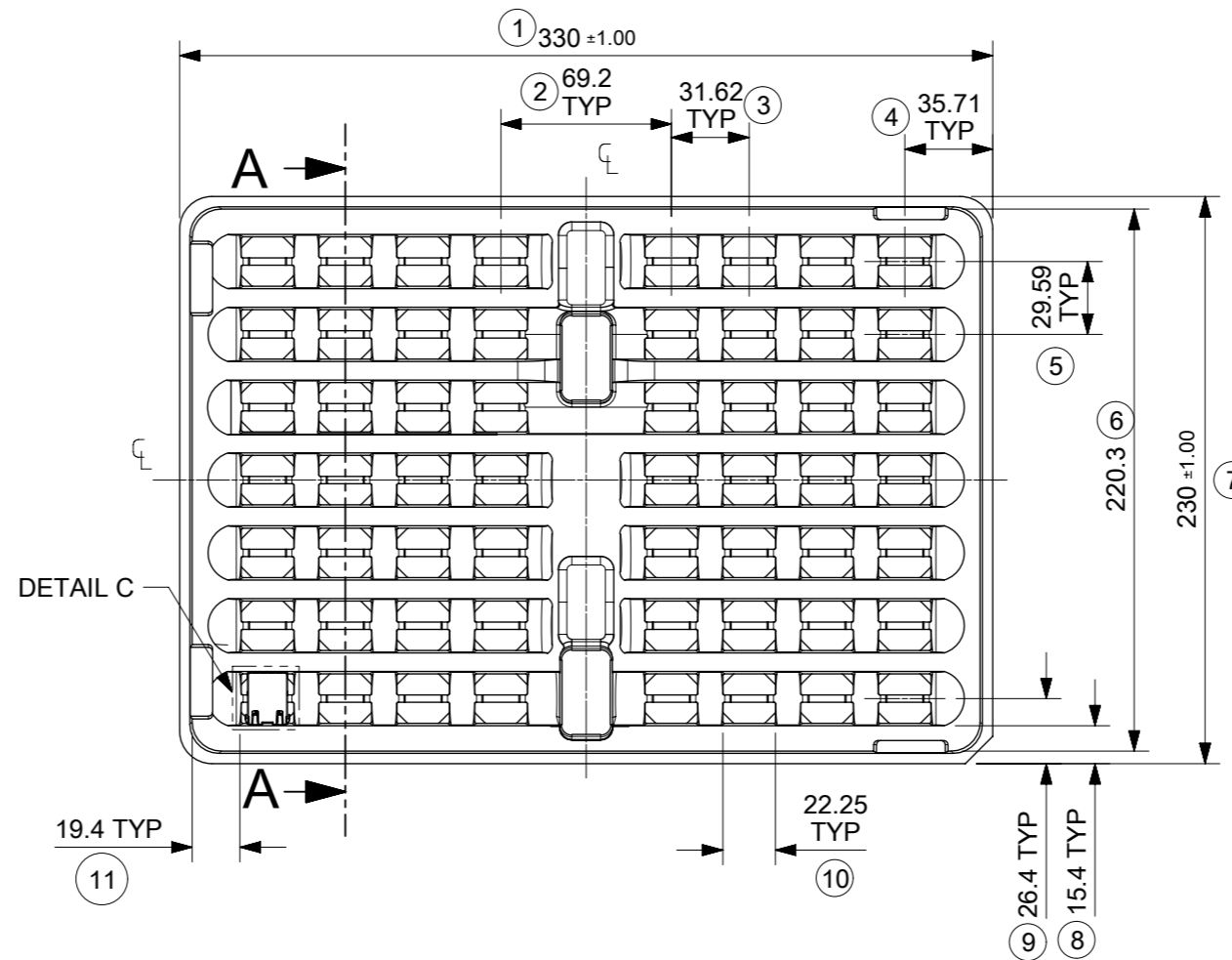

NOTES:

1. MATERIAL: PETA ANTISTATIC
2. THICKNESS: 0.9 mm ± 0.05 mm
3. COLOUR: CLEAR
4. BOW 2 mm MAXIMUM PER 330 mm
5. TWIST 2 mm MAXIMUM PER 330 mm
6. TRAY PART NO. AND RECYCLE LOGO TO BE CLEARLY MARKED ON TRAY
RECYCLE LOGO SHOULD BE APPROPRIATE TO MATERIAL USED
7. WHERE RELEVANT, DIMENSIONS SHOULD BE SYMMETRICAL ABOUT THE CENTRELINE
8. GENERAL PROFILE TOLERANCE $\overline{\cup}$ 0.40 ON NON DIMENSIONED FEATURES

LAST INSPECTION NUMBER USED: 12

THIS DRAWING CONTAINS INFORMATION THAT IS PROPRIETARY TO MOLEX ELECTRONIC TECHNOLOGIES, LLC AND SHOULD NOT BE USED WITHOUT WRITTEN PERMISSION									
DIMENSION UNITS		SCALE		CURRENT REV DESC: REMOVED REFERENCE TO QUANTITY OF TRAYS PER STACK				molex	
mm		1:3							
GENERAL TOLERANCES (UNLESS SPECIFIED)				EC NO: 602124				MXMAG STANDARD AND INVERTED TRAY	
ANGULAR TOL ± 1.0°				DRWN: DSHEA 2018/09/07					
4 PLACES ±				CHK'D: DBYRNES 2019/01/25					
3 PLACES ±				APPR: DBYRNES 2019/01/25					
2 PLACES ± 0.2				INITIAL REVISION:				PRODUCT CUSTOMER DRAWING	
1 PLACE ± 0.5				DRWN: KREILLY 2016/05/06				DOCUMENT NUMBER	
0 PLACES ±				APPR: STGRIFFIN 2016/12/07				934620003	
DRAFT WHERE APPLICABLE MUST REMAIN WITHIN DIMENSIONS		THIRD ANGLE PROJECTION		DRAWING		SERIES		MATERIAL NUMBER	
				A3-SIZE		93462		990250150	
				CUSTOMER		GENERAL MARKET		SHEET NUMBER	
								1 OF 1	

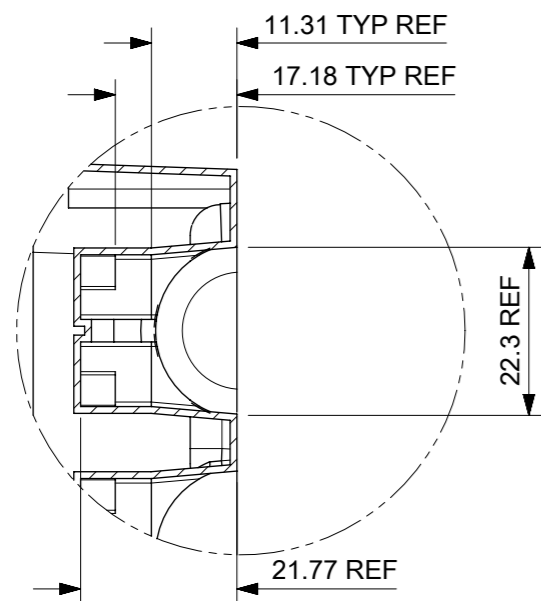

DETAIL B

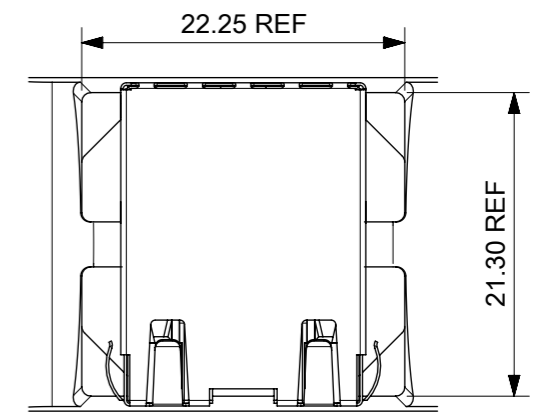
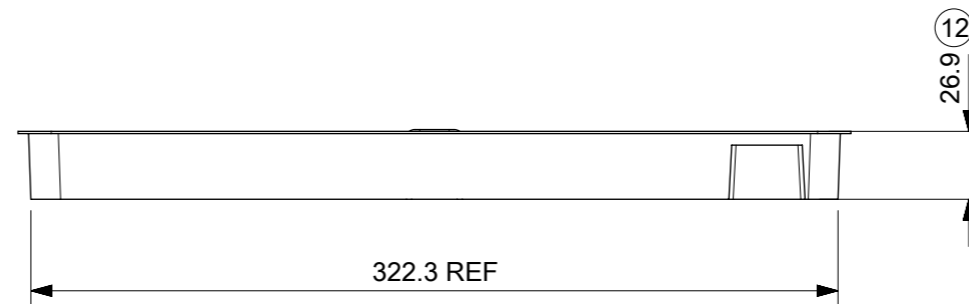

DETAIL C
SCALE 2:1

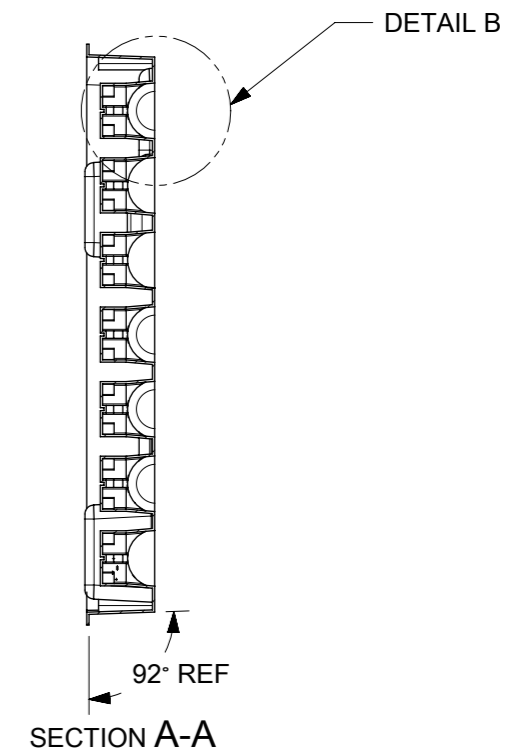
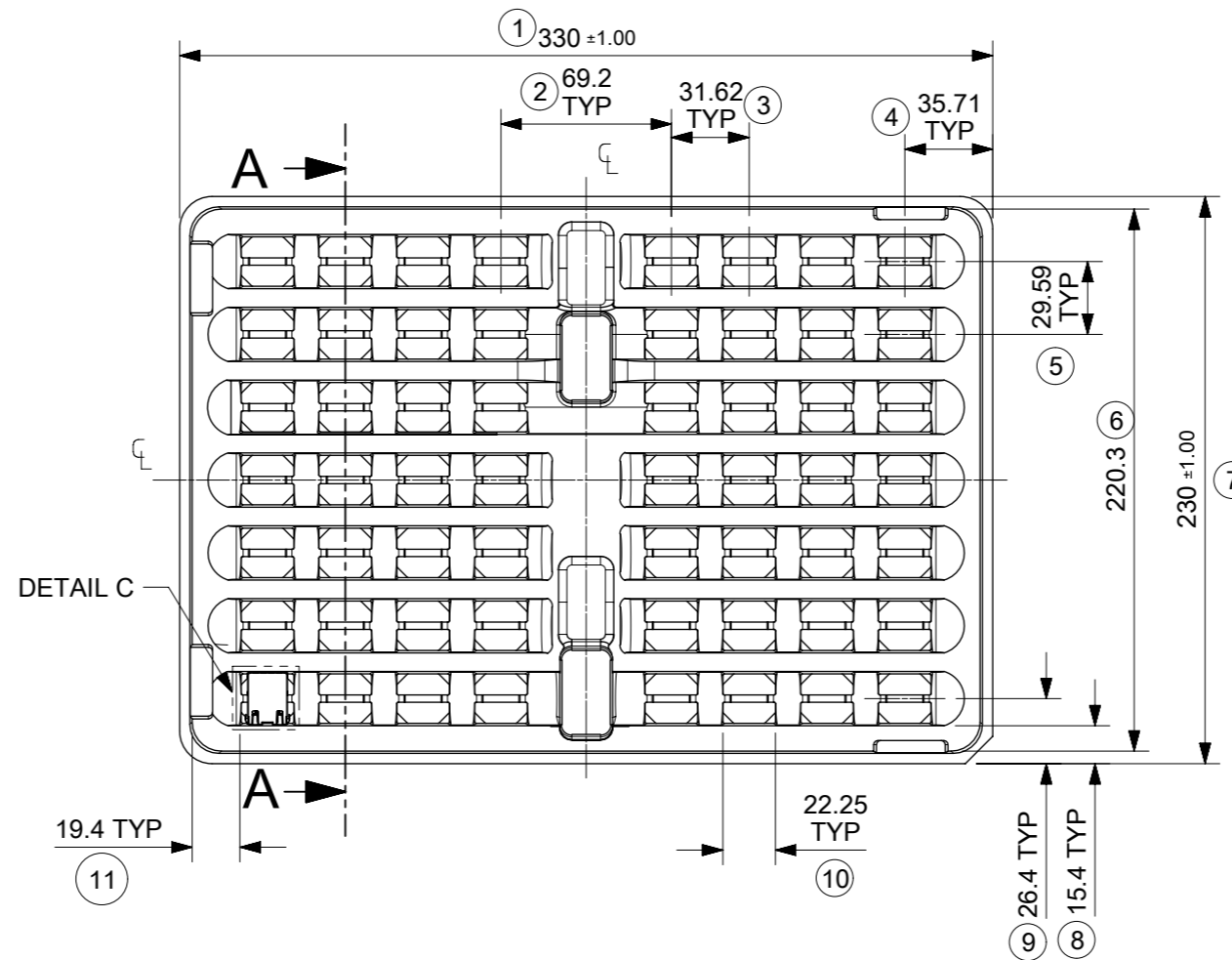

NOTES:

1. MATERIAL: PETA ANTISTATIC
2. THICKNESS: 0.9 mm ± 0.05 mm
3. COLOUR: CLEAR
4. BOW 2 mm MAXIMUM PER 330 mm
5. TWIST 2 mm MAXIMUM PER 330 mm
6. TRAY PART NO. AND RECYCLE LOGO TO BE CLEARLY MARKED ON TRAY
RECYCLE LOGO SHOULD BE APPROPRIATE TO MATERIAL USED
7. WHERE RELEVANT, DIMENSIONS SHOULD BE SYMMETRICAL ABOUT THE CENTRELINE
8. GENERAL PROFILE TOLERANCE $\overline{\cup}$ 0.40 ON NON DIMENSIONED FEATURES

LAST INSPECTION NUMBER USED: 12

THIS DRAWING CONTAINS INFORMATION THAT IS PROPRIETARY TO MOLEX ELECTRONIC TECHNOLOGIES, LLC AND SHOULD NOT BE USED WITHOUT WRITTEN PERMISSION									
DIMENSION UNITS		SCALE		CURRENT REV DESC: REMOVED REFERENCE TO QUANTITY OF TRAYS PER STACK				molex	
mm		1:3							
GENERAL TOLERANCES (UNLESS SPECIFIED)				EC NO: 602124				MXMAG STANDARD AND INVERTED TRAY	
ANGULAR TOL ± 1.0°				DRWN: DSHEA		2018/09/07			
4 PLACES ±				CHK'D: DBYRNES		2019/01/25			
3 PLACES ±				APPR: DBYRNES		2019/01/25			
2 PLACES ± 0.2				INITIAL REVISION:				PRODUCT CUSTOMER DRAWING	
1 PLACE ± 0.5				DRWN: KREILLY		2016/05/06		DOCUMENT NUMBER	
0 PLACES ±				APPR: STGRIFFIN		2016/12/07		934620003	
DRAFT WHERE APPLICABLE MUST REMAIN WITHIN DIMENSIONS		THIRD ANGLE PROJECTION		DRAWING		SERIES		MATERIAL NUMBER	
				A3-SIZE		93462		990250150	
				CUSTOMER		GENERAL MARKET		SHEET NUMBER	
								1 OF 1	

INVERTED PROFILE MAGNETIC JACK
GIGABIT ETHERNET W/LED
AND W/SHIELD TABS

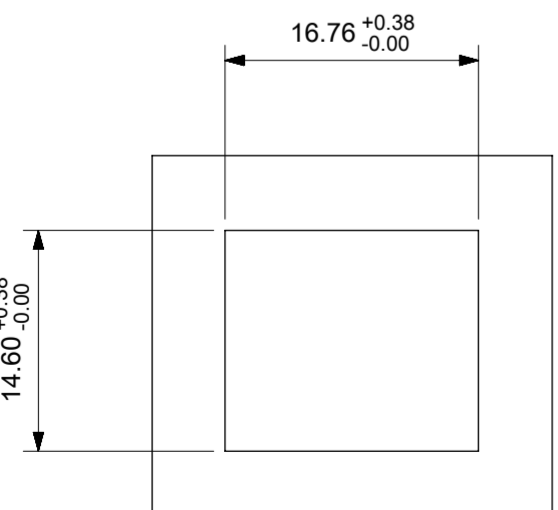
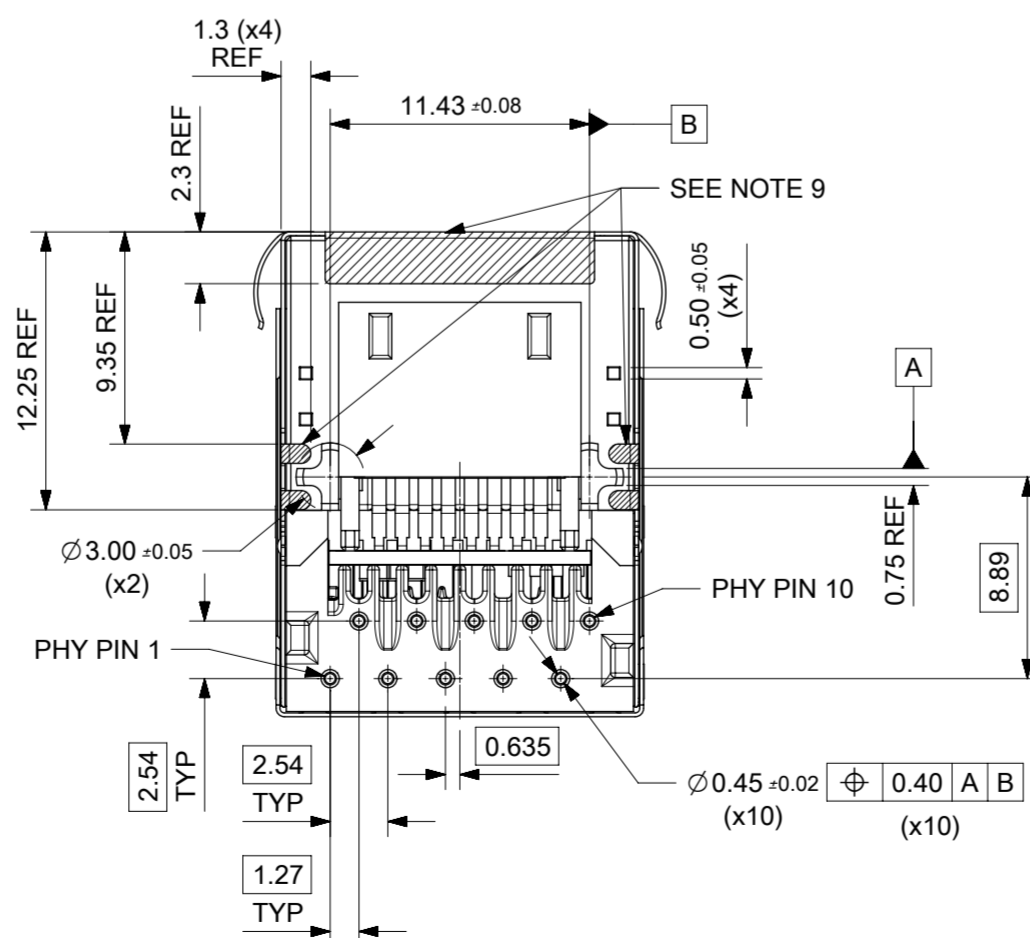
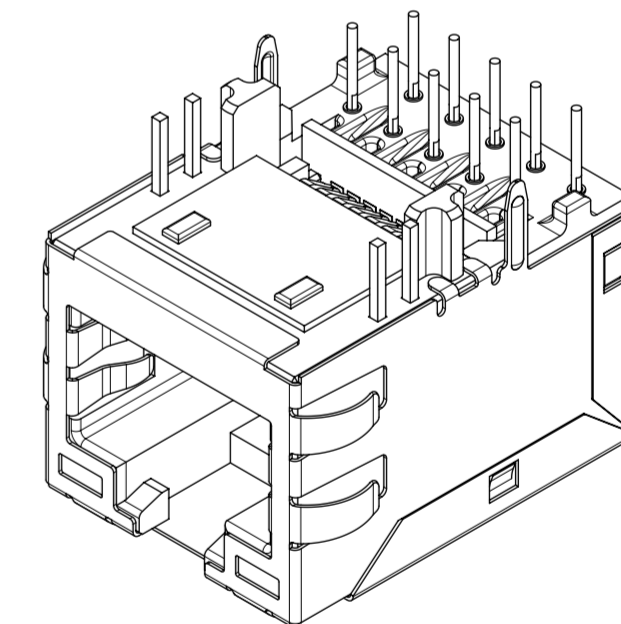
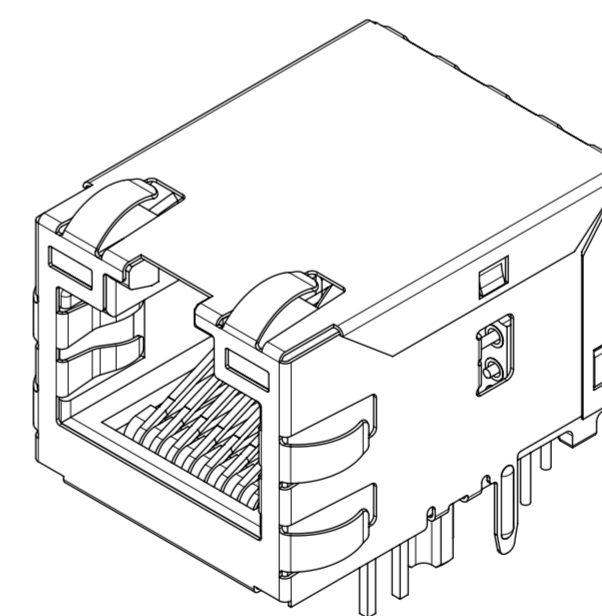
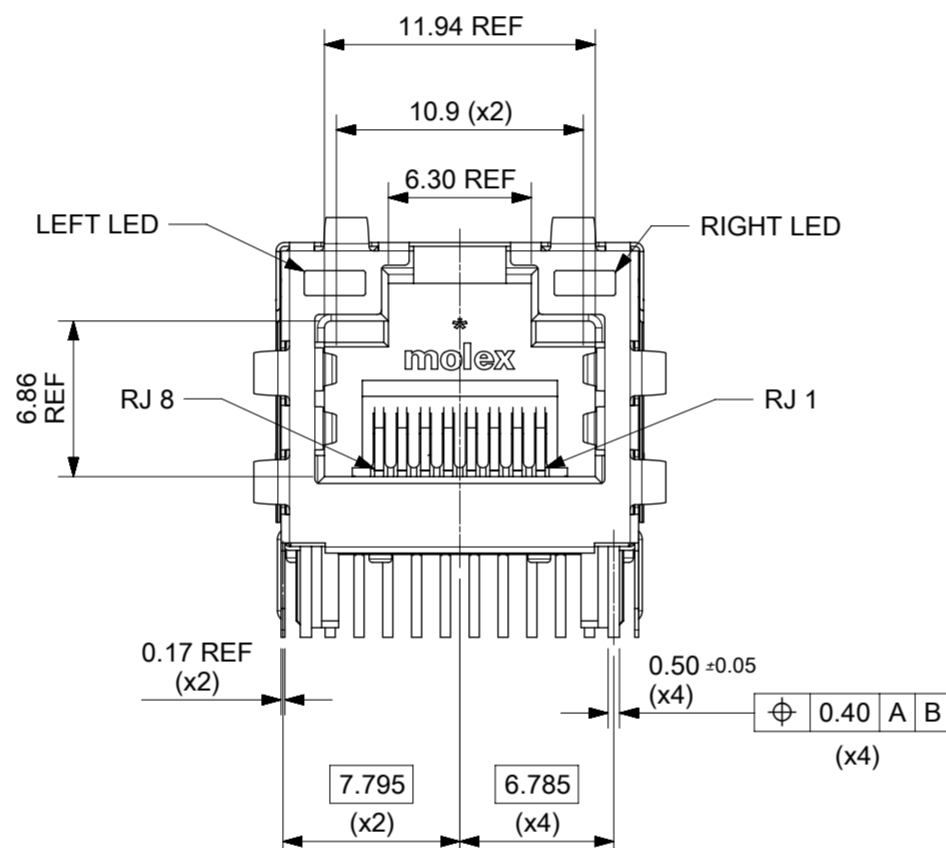
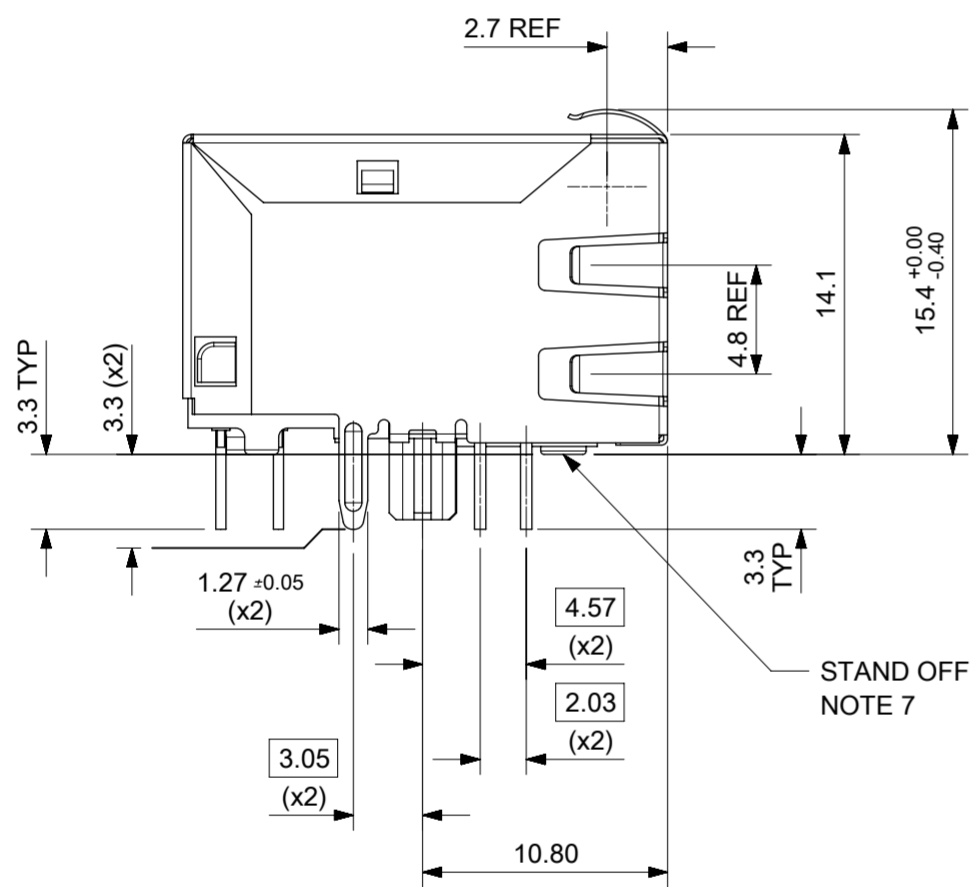
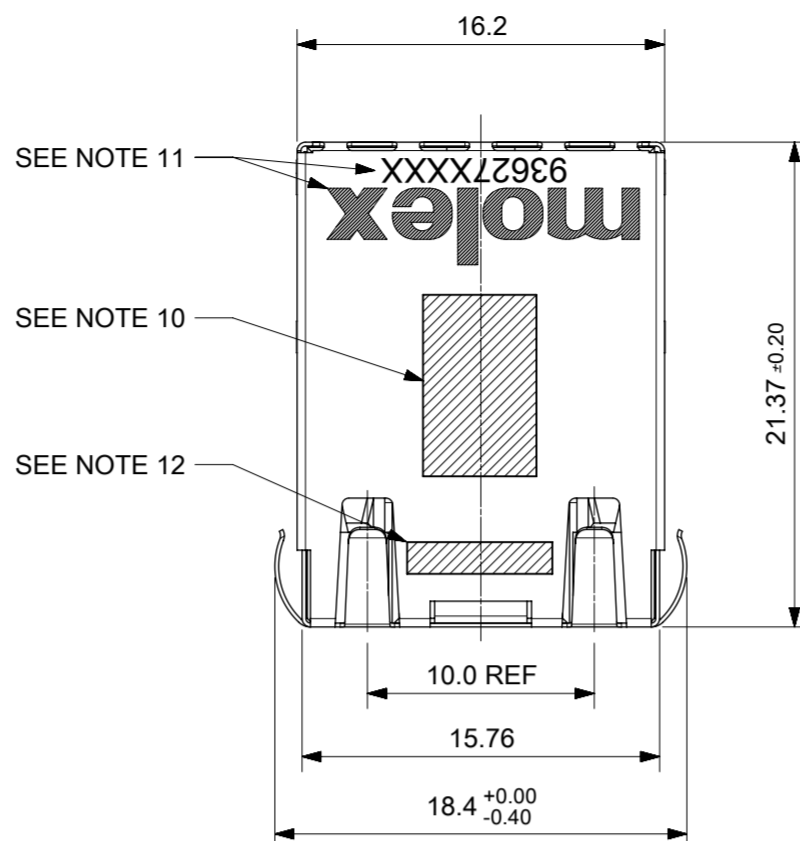

SUGGESTED PANEL CUT-OUT

- NOTES:
- SHIELD MATERIAL: 0.17 mm THICK BRASS PRE-PLATED WITH NICKEL
SOLDER TABS POST DIPPED WITH MIN 1.27 μm TIN
 - HOUSING MATERIAL: LCP, BLACK, UL 94V-0
 - TERMINALS MATERIAL: PHOSPHOR BRONZE
RJ45 CONTACTS PLATING: BASE NICKEL PLATED WITH GOLD
FLASH OVER PALLADIUM NICKEL. REFER TO 934620001 PSP
PHY SOLDER TAILS: COPPER ALLOY
 - MATING INTERFACE ACCORDING TO IEC 60603-7 & TIA-1096-A
 - PRODUCT SPECIFICATION: 934620001 PSP
 - PACKAGING SPECIFICATION: 934620001 PSK TRAY
 - STAND OFF TO SYSTEM BOARD 0.30 mm MIN
 - RECOMMENDED PCB THICKNESS: 1.57 mm
 - SHIELD: AVOID ROUTING TRACES
OR PLACING ANY VIAS BELOW THESE AREAS
 - AREA FOR PICK AND PLACE: 5.0 mm X 8.0 mm
 - INSCRIPTION MARKED BY LASER:
1st : MOLEX
2nd : P/N (SEE BOM)
 - INSCRIPTION MARKED BY LASER:
DATE CODE(DAY/WEEK/YEAR)
 - MATERIAL COMPLIANT TO RoHS DIRECTIVE 2002/95/EC

THIS DRAWING CONTAINS INFORMATION THAT IS PROPRIETARY TO MOLEX ELECTRONIC TECHNOLOGIES, LLC AND SHOULD NOT BE USED WITHOUT WRITTEN PERMISSION		GENERAL TOLERANCES (UNLESS SPECIFIED)		DIMENSION UNITS	SCALE	molex			
mm		3:1		INV PRO MX MAG 8 CORE GIG W/LED W/EMI					
REVISED	2017/05/09	DRWN BY	DATE	KREILLY			2015/08/31		
EC NO: 116686	2017/09/12	CHK'D BY	DATE	DBYRNES			2017/02/22		
DRWN: KREILLY	2017/09/26	APPR BY	DATE	STGRIFFIN			2015/11/20		
CHKD: DSHEA		DRAFT WHERE APPLICABLE MUST REMAIN WITHIN DIMENSIONS			DRAWING SIZE	THIRD ANGLE PROJECTION	SERIES	MATERIAL NUMBER	CUSTOMER
APP: DBYRNES		A2			A2	THIRD ANGLE PROJECTION	93627	SEE TABLE ON SHEET 2	GENERAL MARKET
DOCUMENT NUMBER							936270003	DOC TYPE	PSD
DOC PART							000	DOC PART	000
SHEET NUMBER							1 OF 3		

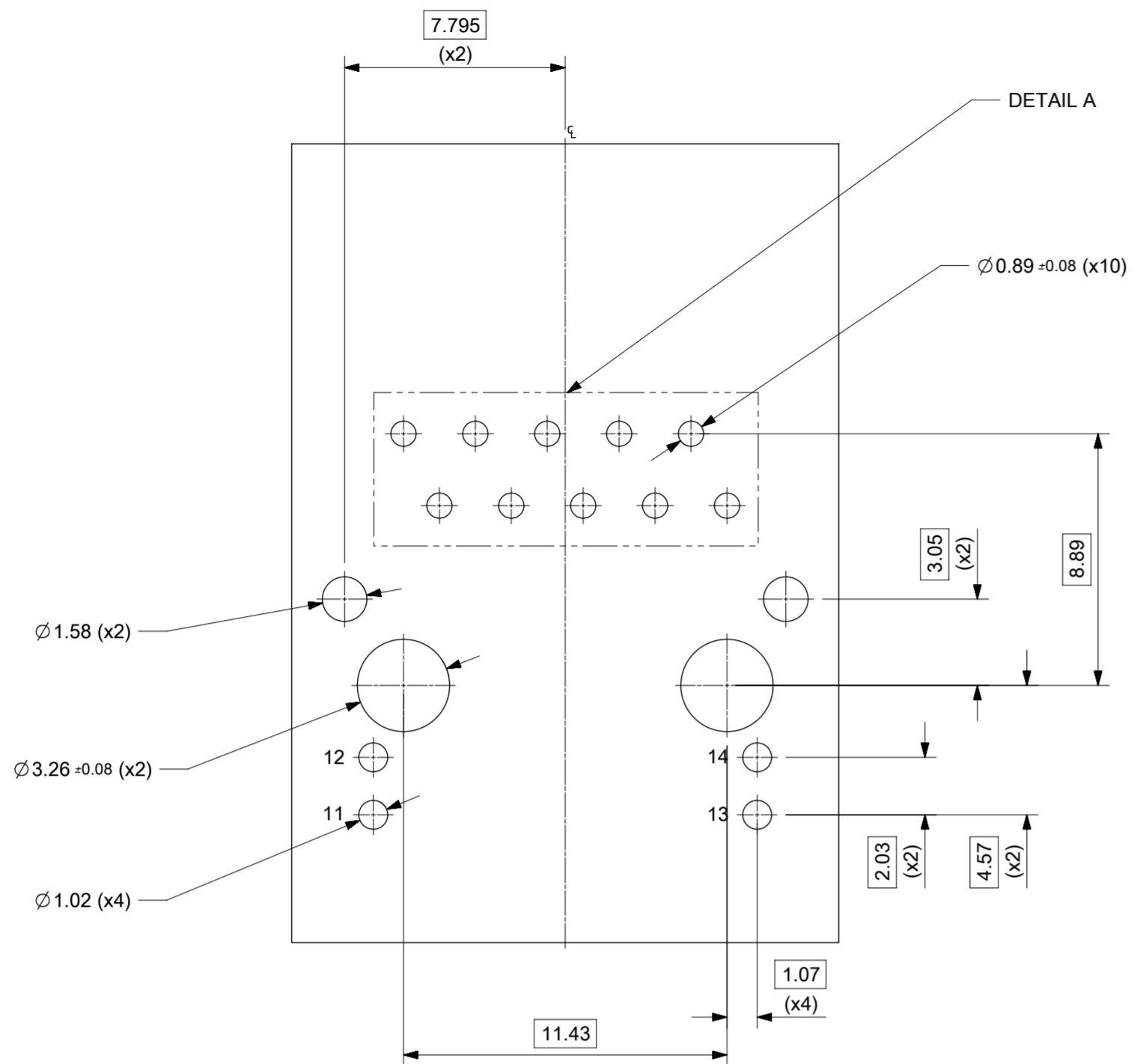

SUGGESTED BOARD LAYOUT
GIGABIT VERSION
COMPONENT SIDE
ALL DIMS REFERENCE DIMS

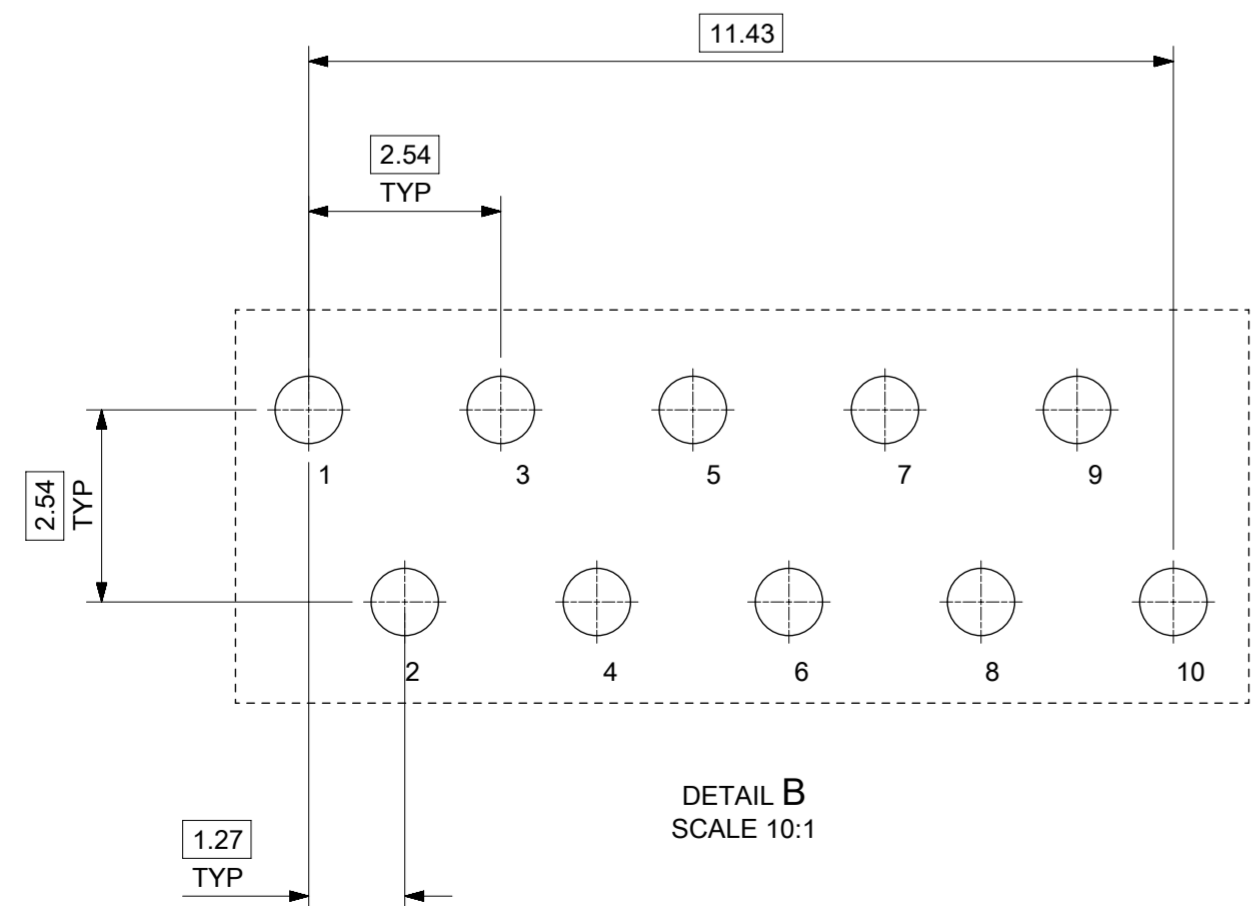

DETAIL B
SCALE 10:1
PIN CONFIGURATION
FOR GIGABIT VERSION

PART NUMBER	LEFT LED	RIGHT LED
93627-3601	GREEN	GREEN
93627-3606	GREEN	YELLOW
93627-3608	GREEN/YELLOW	GREEN/YELLOW

THIS DRAWING CONTAINS INFORMATION THAT IS PROPRIETARY TO MOLEX ELECTRONIC TECHNOLOGIES, LLC AND SHOULD NOT BE USED WITHOUT WRITTEN PERMISSION

REVISED EC NO: 116686 DRWN: KREILLY CHKD: DSHEA REV APPR: DBYRNES	2017/05/09	2017/09/12	2017/09/26	GENERAL TOLERANCES (UNLESS SPECIFIED)	DIMENSION UNITS	SCALE		
				ANGULAR TOL ± 2.0 °	mm	5:1		
	4 PLACES	±		KREILLY	DATE	2015/08/31		INV PRO MX MAG 8 CORE GIG W/LED W/EMI
	3 PLACES	±		CHK'D BY	DATE			
	2 PLACES	±	0.1	DBYRNES	DATE	2017/02/22		
1 PLACE	±	0.2	STGRIFFIN	DATE	2015/11/20	PRODUCT CUSTOMER DRAWING		
0 PLACES	±							
DRAFT WHERE APPLICABLE MUST REMAIN WITHIN DIMENSIONS				DRAWING SIZE	THIRD ANGLE PROJECTION	SERIES: 93627 MATERIAL NUMBER: SEE TABLE CUSTOMER: GENERAL MARKET		
C				A2	DOCUMENT NUMBER: 936270003 DOC TYPE: PSD DOC PART: 000 SHEET NUMBER: 2 OF 3			

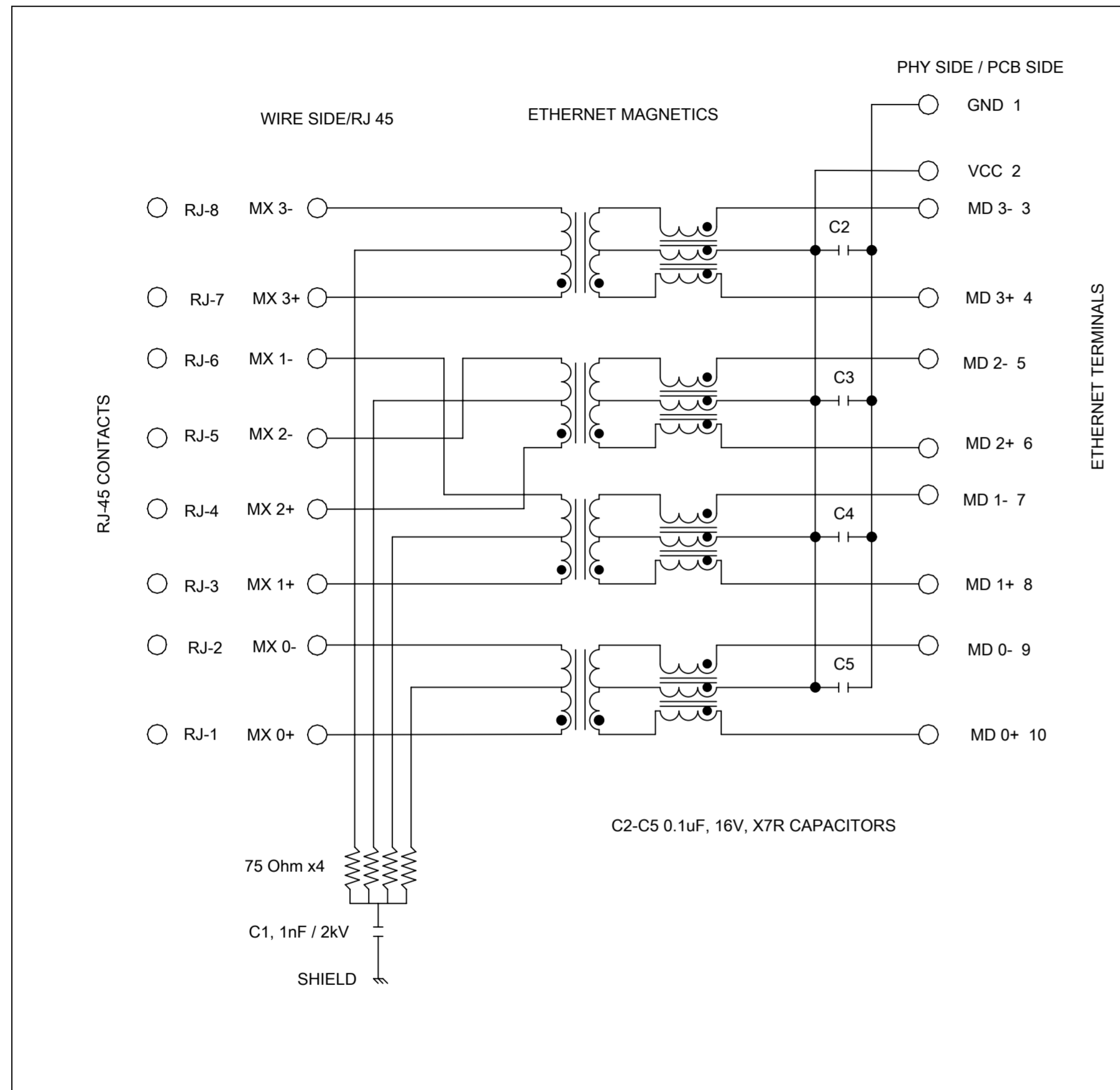

Description	Value	
OCL @100 kHz, 0.1 V 8 mA DC bias (0°C to +70°C)	350 μH min.	
Turns ratio	1CT:1CT	
Transmission characteristics @ 25°C, all four pairs		
Insertion Loss		
Frequency f, (MHz)	Limits (dB max.)	Typical Values (dB max.)
1.0-9.9	0.4+0.1*log(f)	0.5 @ 10 MHz
10-49.9	0.5+0.3*log(f/10)	0.7 @ 50 MHz
50-79.9	1+1.4*log(f/80)	1.0 @ 80 MHz
80-100	1.3+3*log(f/100)	1.3 @ 100 MHz
Return Loss		
Frequency f, (MHz)	Limits (dB min.)	Typical Values (dB min.)
1.0-39.9	18	18 @ 40 MHz
40-100	12-20*log(f/80)	10 @ 100 MHz
CMR		
Frequency f, (MHz)	Limits (dB min.)	Typical Values (dB min.)
1.0-100	30	30 @ 100 MHz
Next		
Frequency f, (MHz)	Limits (dB min.)	Typical Values (dB min.)
1.0-39.9	35	35 @ 40 MHz
40-100	33-20*log(f/50)	27 @ 100 MHz
Isolation PHY to wire side	2.25 kVDC/60sec	

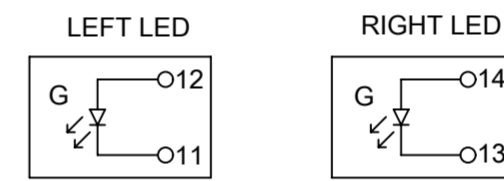

93627-3601

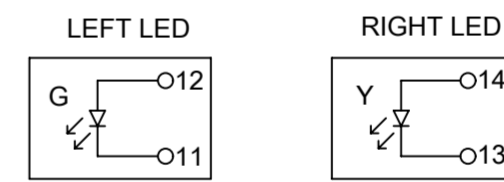

93627-3606

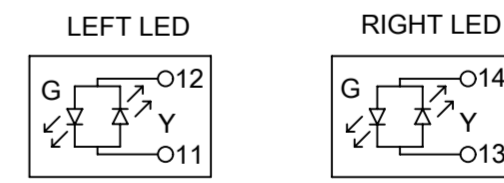

BICOLOUR OPTION

BICOLOUR OPTION

93627-3608

THIS DRAWING CONTAINS INFORMATION THAT IS PROPRIETARY TO MOLEX ELECTRONIC TECHNOLOGIES, LLC AND SHOULD NOT BE USED WITHOUT WRITTEN PERMISSION

REVISIONS		GENERAL TOLERANCES (UNLESS SPECIFIED)		DIMENSION UNITS		SCALE		molex®		
REV	DATE			mm	1:1			INV PRO MX MAG 8 CORE GIG W/LED W/EMI		
1	2017/05/09									
2	2017/09/12	ANGULAR TOL ± 2.0 °		DRWN BY	DATE			PRODUCT CUSTOMER DRAWING		
3	2017/09/26	4 PLACES	±	KREILLY	2015/08/31					
		3 PLACES	±	CHK'D BY	DATE			SERIES MATERIAL NUMBER CUSTOMER		
		2 PLACES	± 0.1	DBYRNES	2017/02/22					
		1 PLACE	± 0.2	APPR BY	DATE			93627	SEE TABLE ON SHEET 2	GENERAL MARKET
		0 PLACES	±	STGRIFFIN	2015/11/20			DOCUMENT NUMBER	DOC TYPE	DOC PART SHEET NUMBER
DRAFT WHERE APPLICABLE MUST REMAIN WITHIN DIMENSIONS				DRAWING SIZE		THIRD ANGLE PROJECTION		936270003	PSD	000 3 OF 3
EC NO: 116686				A2						
DRWN: KREILLY										
CHKD: DSHEA										
REV APPR: DBYRNES										