

## 1.5-Gbps 2 × 2 LVDS CROSSPOINT SWITCH

### FEATURES

- **Designed for Signaling Rates <sup>(1)</sup> Up To 1.5 Gbps**
- **Total Jitter < 65 ps**
- **Pin-Compatible With SN65LVDS22 and SN65LVDM22**
- **25 mV of Receiver Input Threshold Hysteresis Over 0-V to 4-V Common-Mode Range**
- **Inputs Electrically Compatible With CML, LVPECL and LVDS Signal Levels**
- **Propagation Delay Times, 900 ps Maximum**
- **LVDT Integrates 110-Ω Terminating Resistor**
- **Offered in SOIC and TSSOP**

### APPLICATIONS

- **10-G (OC-192) Optical Modules**
- **622-MHz Central Office Clock Distribution**
- **Wireless Basestations**
- **Low Jitter Clock Repeater/Multiplexer**
- **Protection Switching for Serial Backplanes**

(1) The signaling rate of a line is the number of voltage transitions that are made per second expressed in the units bps (bits per second).

### DESCRIPTION

The SN65LVDS122 and SN65LVDT122 are crosspoint switches that use low voltage differential signaling (LVDS) to achieve signaling rates as high as 1.5 Gbps. They are pin-compatible speed upgrades to the SN65LVDS22 and SN65LVDM22. The internal signal paths maintain differential signaling for high speeds and low signal skews. These devices have a 0-V to 4-V common-mode input range that accepts LVDS, LVPECL, or CML inputs. Two logic pins (S0 and S1) set the internal configuration between the differential inputs and outputs. This allows the flexibility to perform the following configurations: 2 × 2 crosspoint switch, 2:1 input multiplexer, 1:2 splitter or dual repeater/translator within a single device. Additionally, SN65LVDT122 incorporates a 110-Ω termination resistor for those applications where board space is a premium. Although these devices are designed for 1.5 Gbps, some applications at a 2-Gbps data rate can be supported depending on loading and signal quality.

The intended application of this device is ideal for loopback switching for diagnostic routines, fanout buffering of clock/data distribution provide protection in fault-tolerant systems, clock multiplexing in optical modules, and for overall signal boosting over extended distances.

The SN65LVDS122 and SN65LVDT122 are characterized for operation from –40°C to 85°C.

### FUNCTIONAL DIAGRAM

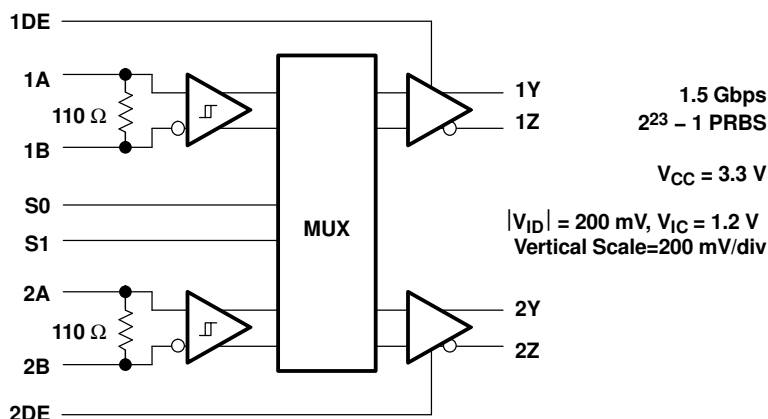

Integrated Termination on SN65LVDT122 Only

### EYE PATTERNS OF OUTPUTS OPERATING SIMULTANEOUSLY

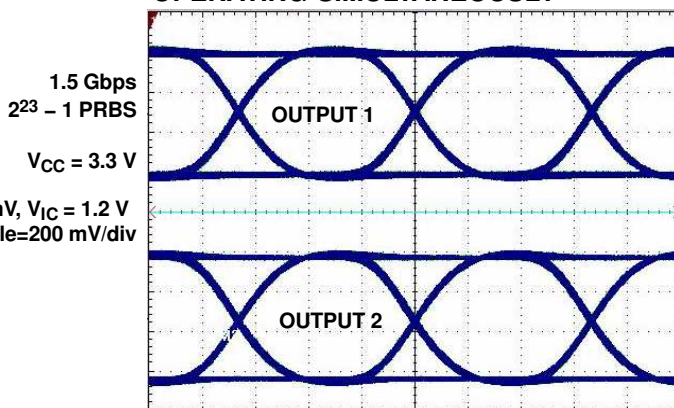

Horizontal Scale = 200 ps/div



Please be aware that an important notice concerning availability, standard warranty, and use in critical applications of Texas Instruments semiconductor products and disclaimers thereto appears at the end of this data sheet.



These devices have limited built-in ESD protection. The leads should be shorted together or the device placed in conductive foam during storage or handling to prevent electrostatic damage to the MOS gates.

### ORDERING INFORMATION

PACKAGE	TERMINATION RESISTOR	PART NUMBER <sup>(1)</sup>	SYMBOLIZATION
SOIC	No	SN65LVDS122D	LVDS122
SOIC	Yes	SN65LVDT122D	LVDT122
TSSOP	No	SN65LVDS122PW	LVDS122
TSSOP	Yes	SN65LVDT122PW	LVDT122

(1) Add the suffix R for taped and reeled carrier

### ABSOLUTE MAXIMUM RATINGS

over operating free-air temperature range unless otherwise noted<sup>(1)</sup>

		SN65LVDS122, SN65LVDT122	
$V_{CC}$	Supply voltage range <sup>(2)</sup>	–0.5 V to 4 V	
Voltage range	(A, B)	–0.7 V to 4.3 V	
	$ V_A - V_B $ (LVDT only)	1 V	
	(DE, S0, S1)	–0.5 V to 4 V	
	(Y, Z)	–0.5 V to 4 V	
ESD	Human Body Model <sup>(3)</sup>	A, B, Y, Z, and GND	±4 kV
		All pins	±2 kV
	Charged-Device Model <sup>(4)</sup>	All pins	±1500 V
Continuous power dissipation		See Dissipation Rating Table	
$T_{stg}$	Storage temperature range	–65°C to 150°C	
Lead temperature 1,6 mm (1/16 inch) from case for 10 seconds		260°C	

- (1) Stresses beyond those listed under "absolute maximum ratings" may cause permanent damage to the device. These are stress ratings only, and functional operation of the device at these or any other conditions beyond those indicated under "recommended operating conditions" is not implied. Exposure to absolute-maximum-rated conditions for extended periods may affect device reliability.
- (2) All voltage values, except differential I/O bus voltages, are with respect to network ground terminal.
- (3) Tested in accordance with JEDEC Standard 22, Test Method A114-A.7.
- (4) Tested in accordance with JEDEC Standard 22, Test Method C101.

### RECOMMENDED OPERATING CONDITIONS

		MIN	NOM	MAX	UNIT
$V_{CC}$	Supply voltage	3	3.3	3.6	V
$V_{IH}$	High-level input voltage	S0, S1, 1DE, 2DE		4	V
$V_{IL}$	Low-level input voltage	S0, S1, 1DE, 2DE		0.8	V
$ V_{ID} $	Magnitude of differential input voltage	LVDS		1	V
		LVDT		0.8	
Input voltage (any combination of common-mode or input signals)		0		4	V
$T_A$	Operating free-air temperature	–40		85	°C

### PACKAGE DISSIPATION RATINGS

PACKAGE	$T_A \leq 25^\circ\text{C}$ POWER RATING	DERATING FACTOR <sup>(1)</sup> ABOVE $T_A = 25^\circ\text{C}$	$T_A = 85^\circ\text{C}$ POWER RATING
PW	712 mW	6.2 mW/°C	340 mW
D	1002 mW	8.7 mW/°C	480 mW

(1) This is the inverse of the junction-to-ambient thermal resistance when board-mounted and with no air flow.

## INPUT ELECTRICAL CHARACTERISTICS

over recommended operating conditions (unless otherwise noted)

PARAMETER		TEST CONDITIONS	MIN	TYP <sup>(1)</sup>	MAX	UNIT	
V <sub>IT+</sub>	Positive-going differential input voltage threshold	See Figure 1 and Table 1			100	mV	
V <sub>IT-</sub>	Negative-going differential input voltage threshold	See Figure 1 and Table 1	-100 <sup>(2)</sup>			mV	
V <sub>ID(HYS)</sub>	Differential input voltage hysteresis (V <sub>IT+</sub> - V <sub>IT-</sub> )			25		mV	
I <sub>IH</sub>	High-level input current	DE	V <sub>IH</sub> = 2	-10	0	μA	
		S0, S1		0	20		
I <sub>IL</sub>	Low-level input current	DE	V <sub>IL</sub> = 0.8 V	-10	0	μA	
		S0, S1			20		
I <sub>CC</sub>	Supply current	R <sub>L</sub> = 100 Ω		80	100	mA	
		Disabled		35	45		
I <sub>I</sub>	Input current (A or B inputs 'LVDS)	V <sub>I</sub> = 0 V or 2.4 V, Other input at 1.2 V		-20	20	μA	
		V <sub>I</sub> = 4 V, Other input at 1.2 V		0	33		
	Input current (A or B inputs 'LVDT)	V <sub>I</sub> = 0 V or 2.4 V, Other input open		-40	40	μA	
		V <sub>I</sub> = 4 V, Other input open		0	66		
I <sub>I(OFF)</sub>	Input current (A or B inputs 'LVDS)	V <sub>CC</sub> = 1.5 V, V <sub>I</sub> = 0 V or 2.4 V, Other input at 1.2 V		-20	20	μA	
		V <sub>CC</sub> = 1.5 V, V <sub>I</sub> = 2.4 V or 4 V, Other input at 1.2 V		0	33		
	Input current (A or B inputs 'LVDT)	V <sub>CC</sub> = 1.5 V, V <sub>I</sub> = 0 V or 2.4 V, Other input open		-40	40	μA	
		V <sub>CC</sub> = 1.5 V, V <sub>I</sub> = 2.4 V or 4 V, Other input open		0	66		
I <sub>IO</sub>	Input offset current ( I <sub>IA</sub> - I <sub>IB</sub>  ) 'LVDS	V <sub>IA</sub> = V <sub>IB</sub> , 0 ≤ V <sub>IA</sub> ≤ 4 V		-6	6	μA	
R <sub>T</sub>	Termination resistance ('LVDT)	V <sub>ID</sub> = 300 mV and 500 mV, V <sub>IC</sub> = 0 V to 2.4 V		90	110	132	Ω
	Termination resistance ('LVDT with power-off)	V <sub>ID</sub> = 300 mV and 500 mV, V <sub>CC</sub> = 1.5 V, V <sub>IC</sub> = 0 V to 2.4 V		90	110	132	
C <sub>I</sub>	Differential input capacitance ('LVDT with power-off)	V <sub>I</sub> = 0.4 sin(4E6πt) + 0.5 V			3	pF	
		Powered down (V <sub>CC</sub> = 1.5 V)			3		

(1) All typical values are at 25°C and with a 3.3-V supply.

(2) The algebraic convention in which the least positive (most negative) limit is designated as minimum is used in this data sheet.

## OUTPUT ELECTRICAL CHARACTERISTICS

over recommended operating conditions (unless otherwise noted)

PARAMETER		TEST CONDITIONS	MIN	TYP <sup>(1)</sup>	MAX	UNIT
V <sub>OD</sub>	Differential output voltage magnitude	See Figure 2	247	310	454	mV
Δ V <sub>OD</sub>	Change in differential output voltage magnitude between logic states		-50		50	
V <sub>OC(SS)</sub>	Steady-state common-mode output voltage	See Figure 3	1.125		1.375	V
ΔV <sub>OC(SS)</sub>	Change in steady-state common-mode output voltage between logic states		-50		50	mV
V <sub>OC(PP)</sub>	Peak-to-peak common-mode output voltage			50	150	mV
I <sub>OS</sub>	Short-circuit output current	V <sub>O(Y)</sub> or V <sub>O(Z)</sub> = 0 V	-24		24	mA
I <sub>OS(D)</sub>	Differential short-circuit output current	V <sub>OD</sub> = 0 V	-12		12	mA
I <sub>OZ</sub>	High-impedance output current	V <sub>OD</sub> = 600 mV	-1		1	μA
		V <sub>O</sub> = 0 V or V <sub>CC</sub>	-1		1	
C <sub>O</sub>	Differential output capacitance	V <sub>I</sub> = 0.4 sin(4E6πt) + 0.5 V			3	pF

(1) All typical values are at 25°C and with a 3.3-V supply.

## TIMING CHARACTERISTICS

PARAMETER		TEST CONDITIONS	MIN	NOM	MAX	UNIT
$t_{SET}$	Input to select setup time		0			ns
$t_{HOLD}$	Input to select hold time		0.5			ns
$t_{SWITCH}$	Select to switch output		1	2	2.6	ns

## SWITCHING CHARACTERISTICS

over recommended operating conditions (unless otherwise noted)

PARAMETER		TEST CONDITIONS	MIN	NOM <sup>(1)</sup>	MAX	UNIT
$t_{PLH}$	Propagation delay time, low-to-high-level output	See Figure 4	400	650	900	ps
$t_{PHL}$	Propagation delay time, high-to-low-level output		400	650	900	ps
$t_r$	Differential output signal rise time (20% - 80%)				280	ps
$t_f$	Differential output signal fall time (20% - 80%)				280	ps
$t_{sk(p)}$	Pulse skew ( $ t_{PHL} - t_{PLH} $ ) <sup>(2)</sup>			10	50	ps
$t_{sk(pp)}$	Part-to-part skew <sup>(3)</sup>	$V_{ID} = 0.2\text{ V}$			100	ps
$t_{jit(per)}$	Period jitter, rms (1 standard deviation) <sup>(4)</sup>	750 MHz clock input <sup>(5)</sup>		1	2.2	ps
$t_{jit(cc)}$	Cycle-to-cycle jitter (peak) <sup>(4)</sup>	750 MHz clock input <sup>(6)</sup>		10	17	ps
$t_{jit(pp)}$	Peak-to-peak jitter <sup>(4)</sup>	1.5 Gbps $2^{23}-1$ PRBS input <sup>(7)</sup>		33	65	ps
$t_{jit(det)}$	Deterministic jitter, peak-to-peak <sup>(4)</sup>	1.5 Gbps $2^7-1$ PRBS input <sup>(8)</sup>		17	50	ps
$t_{PHZ}$	Propagation delay time, high-level-to-high-impedance output	See Figure 5		6	8	ns
$t_{PLZ}$	Propagation delay time, low-level-to-high-impedance output	See Figure 5		6	8	ns
$t_{PZH}$	Propagation delay time, high-impedance-to-high-level output	See Figure 5		4	6	ns
$t_{PZL}$	Propagation delay time, high-impedance-to-low-level output	See Figure 5		4	6	ns
$t_{sk(o)}$	Output skew <sup>(9)</sup>			15	40	ps

- (1) All typical values are at 25°C and with a 3.3-V supply.
- (2)  $t_{sk(p)}$  is the magnitude of the time difference between the  $t_{PLH}$  and  $t_{PHL}$  of any output of a single device.
- (3)  $t_{sk(pp)}$  is the magnitude of the difference in propagation delay times between any specified terminals of two devices when both devices operate with the same supply voltages, at the same temperature, and have identical packages and test circuits.
- (4) Jitter is specified by design and characterization. Stimulus jitter has been subtracted.
- (5) Input voltage =  $V_{ID} = 200\text{ mV}$ , 50% duty cycle at 750 MHz,  $t_r = t_f = 50\text{ ps}$  (20% to 80%), measured over 1000 samples.
- (6) Input voltage =  $V_{ID} = 200\text{ mV}$ , 50% duty cycle at 750 MHz,  $t_r = t_f = 50\text{ ps}$  (20% to 80%).
- (7) Input voltage =  $V_{ID} = 200\text{ mV}$ ,  $2^{23}-1$  PRBS pattern at 1.5 Gbps,  $t_r = t_f = 50\text{ ps}$  (20% to 80%), measured over 200 k samples.
- (8) Input voltage =  $V_{ID} = 200\text{ mV}$ ,  $2^7-1$  PRBS pattern at 1.5 Gbps,  $t_r = t_f = 50\text{ ps}$  (20% to 80%).
- (9) Output skew is the magnitude of the time delay difference between the outputs of a single device with all inputs tied together.

## PIN ASSIGNMENT

D OR PW PACKAGE  
(TOP VIEW)

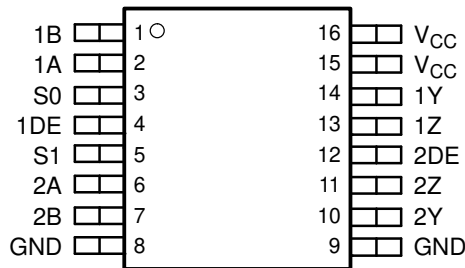

Circuit Function Table

INPUTS <sup>(1)</sup>						OUTPUTS <sup>(1)</sup>		LOGIC DIAGRAM
1V <sub>ID</sub>	2V <sub>ID</sub>	S1	S0	1DE	2DE	1V <sub>OD</sub>	2V <sub>OD</sub>	
X	X	X	X	L	L	Z	Z	
> 100 mV	X	L	L	H	L	H	Z	
< -100 mV	X	L	L	H	L	L	Z	
< -100 mV	X	L	L	H	H	L	L	
> 100 mV	X	L	L	H	H	H	H	
> 100 mV	X	L	L	L	H	Z	H	
< -100 mV	X	L	L	L	H	Z	L	
> 100 mV	X	H	L	H	L	H	Z	
< -100 mV	X	H	L	H	L	L	Z	
< -100 mV	< -100 mV	H	L	H	H	L	L	
< -100 mV	> 100 mV	H	L	H	H	L	H	
> 100 mV	< -100 mV	H	L	H	H	H	L	
> 100 mV	> 100 mV	H	L	H	H	H	H	
X	> 100 mV	H	L	L	H	Z	H	
X	< -100 mV	H	L	L	H	Z	L	
X	> 100 mV	L	H	H	L	H	Z	
X	< -100 mV	L	H	H	L	L	Z	
X	> 100 mV	L	H	L	H	Z	L	
X	< -100 mV	L	H	L	H	Z	L	
X	> 100 mV	H	H	H	L	H	Z	
X	< -100 mV	H	H	H	L	L	Z	
< -100 mV	< -100 mV	H	H	H	H	L	L	
< -100 mV	> 100 mV	H	H	H	H	H	L	
> 100 mV	< -100 mV	H	H	H	H	L	H	
> 100 mV	> 100 mV	H	H	H	H	H	H	
> 100 mV	X	H	H	L	H	Z	H	
< -100 mV	X	H	H	L	H	Z	L	

(1) H = high level, L = low level, Z = high impedance, X = don't care

PARAMETER MEASUREMENT INFORMATION

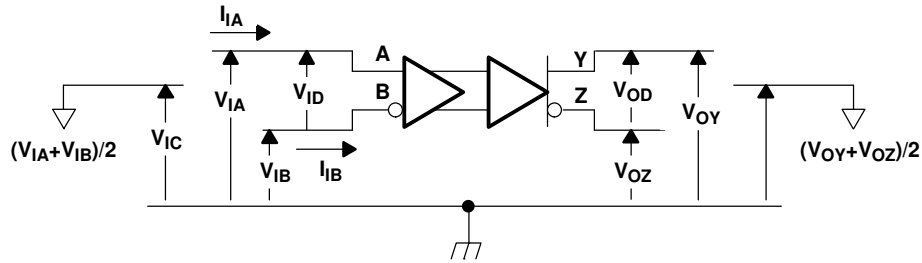

Figure 1. Voltage and Current Definitions

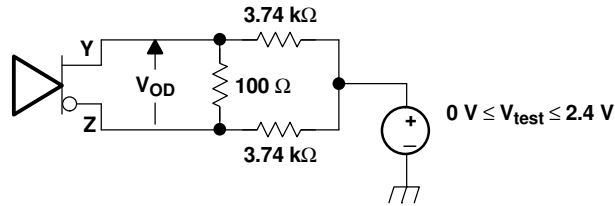
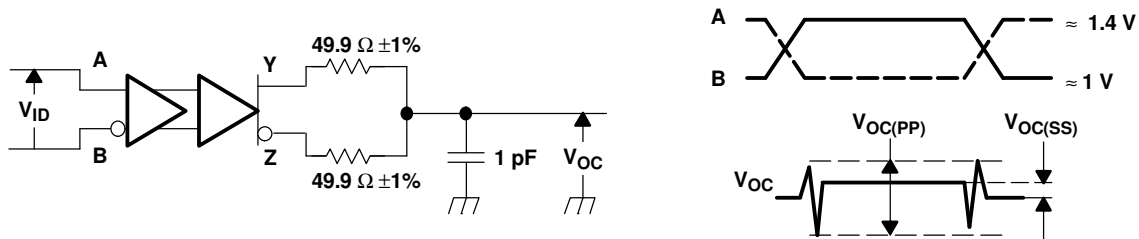
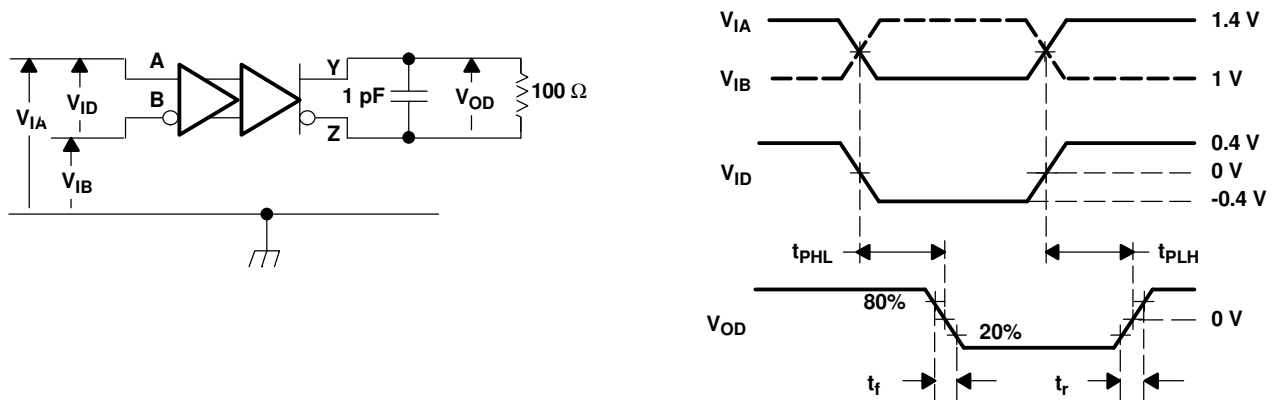

Figure 2. Differential Output Voltage ( $V_{OD}$ ) Test Circuit



NOTE: All input pulses are supplied by a generator having the following characteristics:  $t_r$  or  $t_f \leq 0.25$  ns, pulse repetition rate (PRR) = 0.5 Mpps, pulse width =  $500 \pm 10$  ns;  $R_L = 100 \Omega$ ;  $C_L$  includes instrumentation and fixture capacitance within 0,06 mm of the D.U.T.; the measurement of  $V_{OC(PP)}$  is made on test equipment with a  $-3$ -dB bandwidth of at least 300 MHz.

Figure 3. Test Circuit and Definitions for the Driver Common-Mode Output Voltage



NOTE: All input pulses are supplied by a generator having the following characteristics:  $t_r$  or  $t_f \leq 0.25$  ns, pulse repetition rate (PRR) = 0.5 Mpps, pulse width =  $500 \pm 10$  ns.  $C_L$  includes instrumentation and fixture capacitance within 0,06 mm of the D.U.T.

Figure 4. Timing Test Circuit and Waveforms

PARAMETER MEASUREMENT INFORMATION (continued)

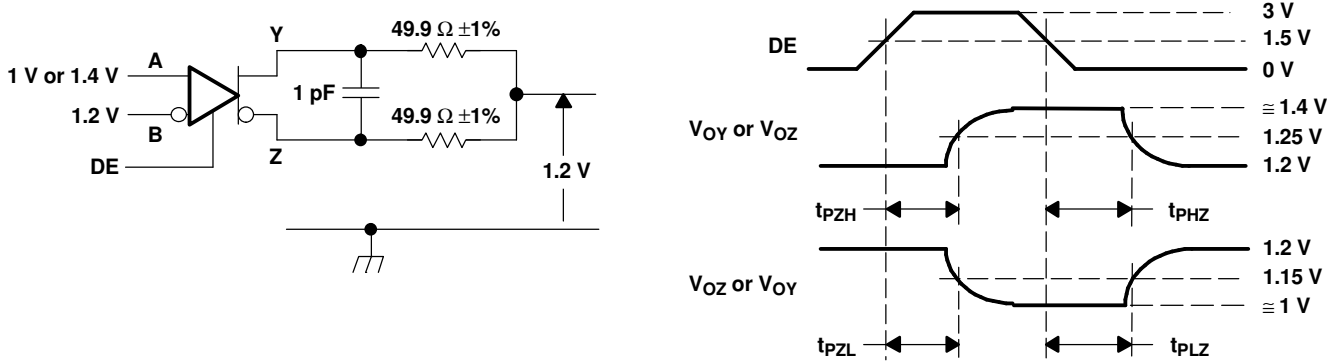

NOTE: All input pulses are supplied by a generator having the following characteristics:  $t_r$  or  $t_f \leq 1$  ns, pulse repetition rate (PRR) = 0.5 Mpps, pulse width =  $500 \pm 10$  ns.  $C_L$  includes instrumentation and fixture capacitance within 0,06 mm of the D.U.T.

Figure 5. Enable and Disable Time Circuit and Definitions

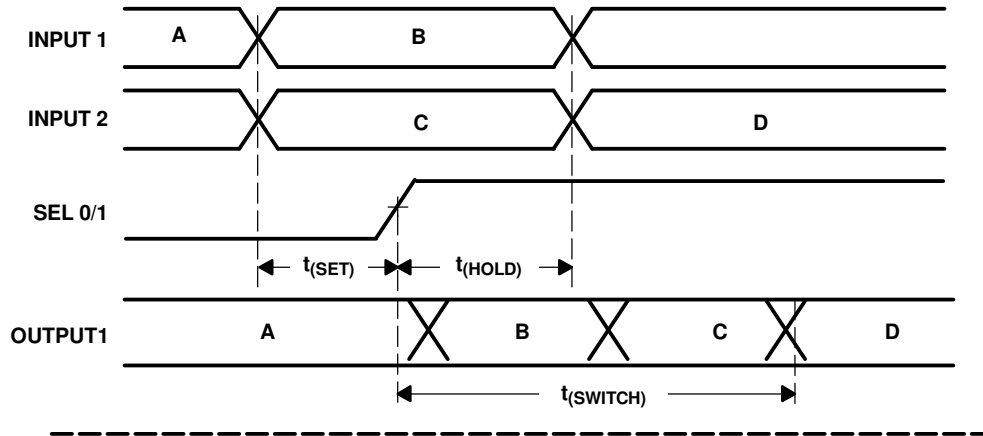

Figure 6. Example Switch, Setup, and Hold Times

**PARAMETER MEASUREMENT INFORMATION (continued)**

$t_{(SET)}$  and  $t_{(HOLD)}$  times specify that data must be in a stable state before and after multiplex control switches.

**Table 1. Receiver Input Voltage Threshold Test**

APPLIED VOLTAGES		RESULTING DIFFERENTIAL INPUT VOLTAGE	RESULTING COMMON-MODE INPUT VOLTAGE	OUTPUT <sup>(1)</sup>
$V_{IA}$	$V_{IB}$	$V_{ID}$	$V_{IC}$	
1.25 V	1.15 V	100 mV	1.2 V	H
1.15 V	1.25 V	-100 mV	1.2 V	L
4.0 V	3.9 V	100 mV	3.95 V	H
3.9 V	4.0 V	-100 mV	3.95 V	L
0.1 V	0.0 V	100 mV	0.05 V	H
0.0 V	0.1 V	-100 mV	0.05 V	L
1.7 V	0.7 V	1000 mV	1.2 V	H
0.7 V	1.7 V	-1000 mV	1.2 V	L
4.0 V	3.0 V	1000 mV	3.5 V	H
3.0 V	4.0 V	-1000 mV	3.5 V	L
1.0 V	0.0 V	1000 mV	0.5 V	H
0.0 V	1.0 V	-1000 mV	0.5 V	L

(1) H = high level, L = low level



**EQUIVALENT INPUT AND OUTPUT SCHEMATIC DIAGRAMS**

**INPUT LVDS122**

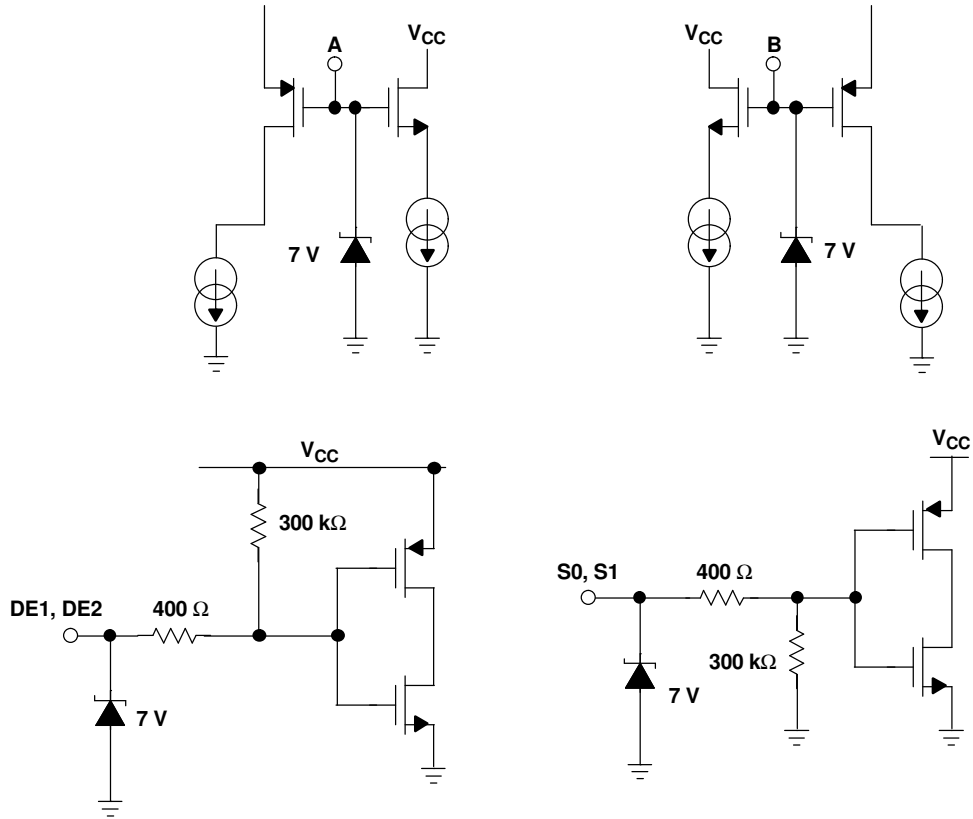

**OUTPUT LVDS122**

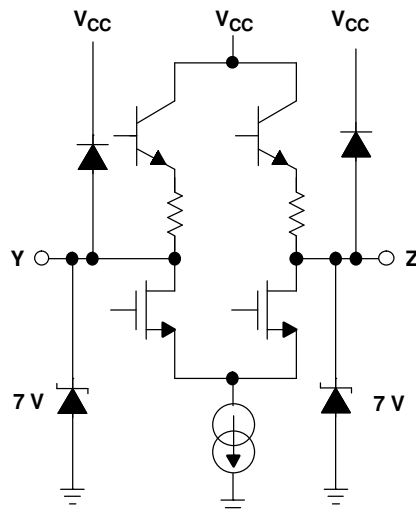

TYPICAL CHARACTERISTICS

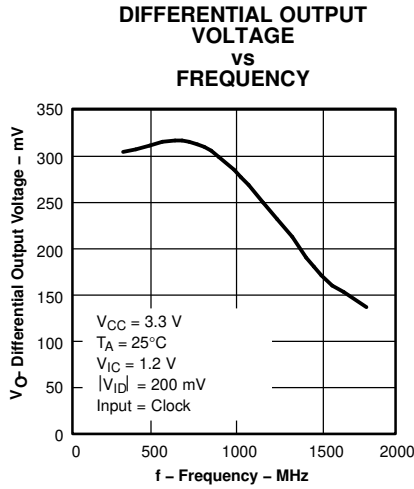

Figure 7.

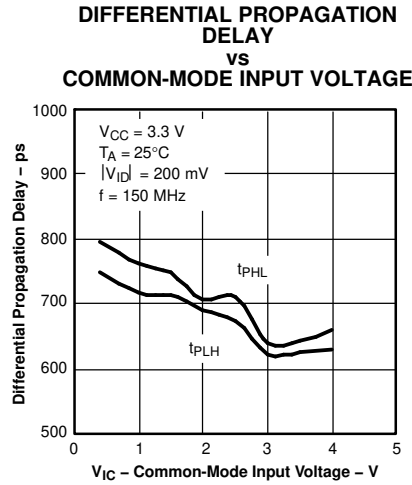

Figure 8.

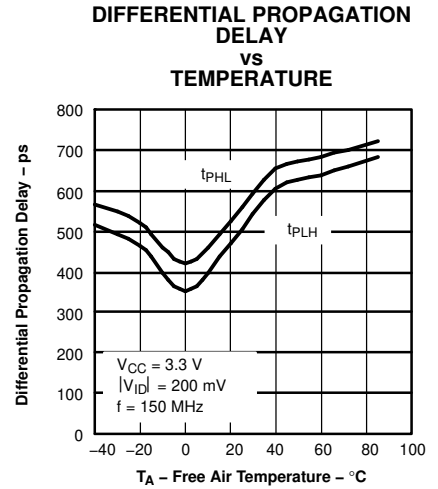

Figure 9.

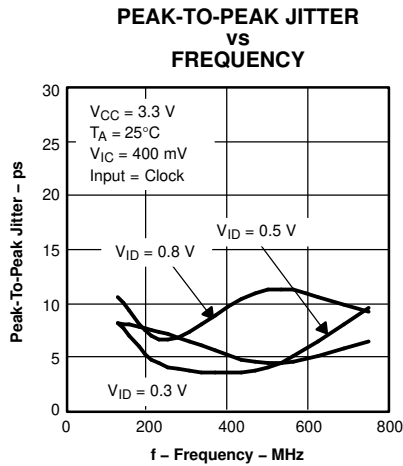

Figure 10.

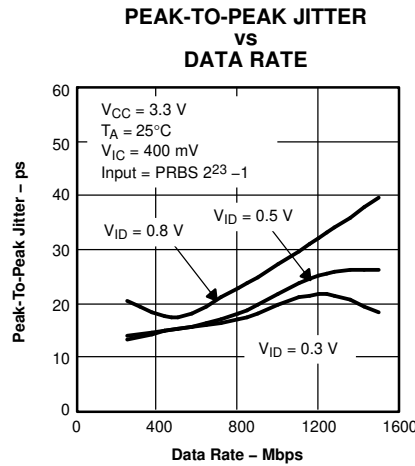

Figure 11.

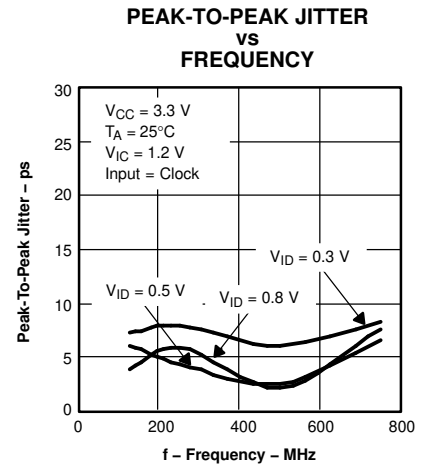

Figure 12.

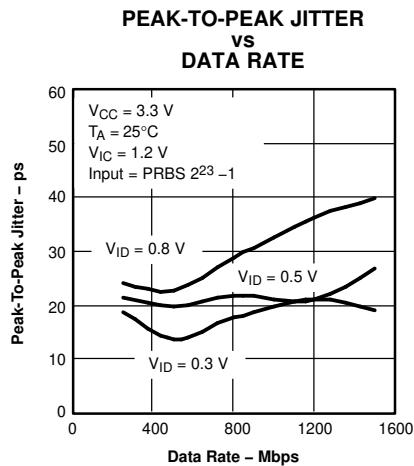

Figure 13.

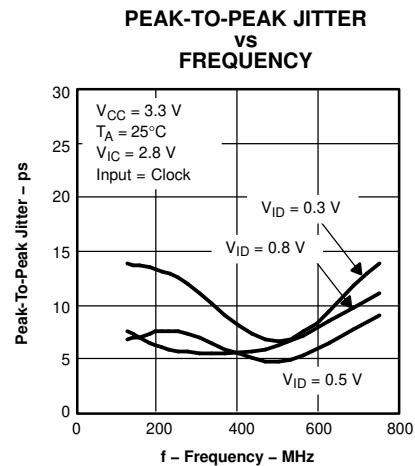

Figure 14.

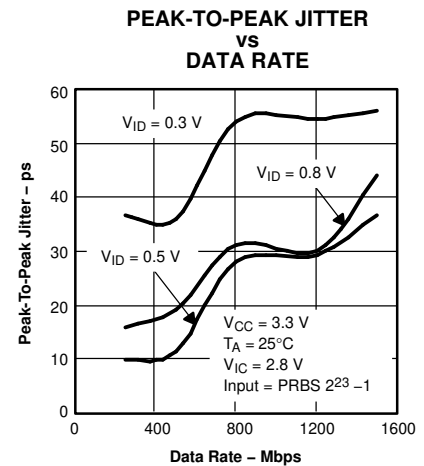

Figure 15.

TYPICAL CHARACTERISTICS (continued)

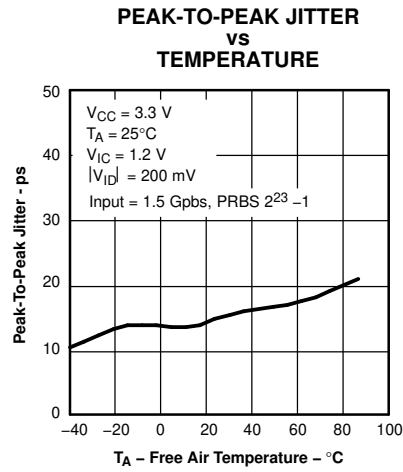

Figure 16.

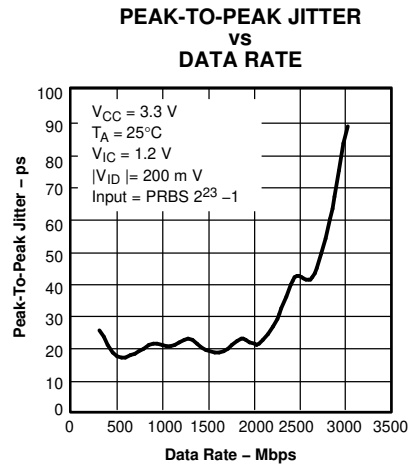
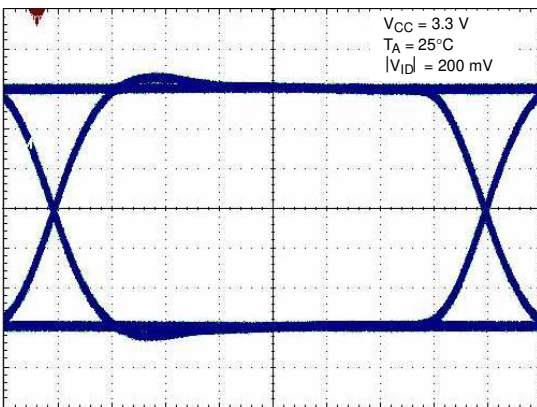

Figure 17.

**LVDS122  
622 Mbps, 2<sup>23</sup>-1 PRBS**



Horizontal Scale= 200 ps/div  
LVPECL-to-LVDS

Figure 18.

**LVDS122  
1.5 Gbps, 2<sup>23</sup>-1 PRBS**

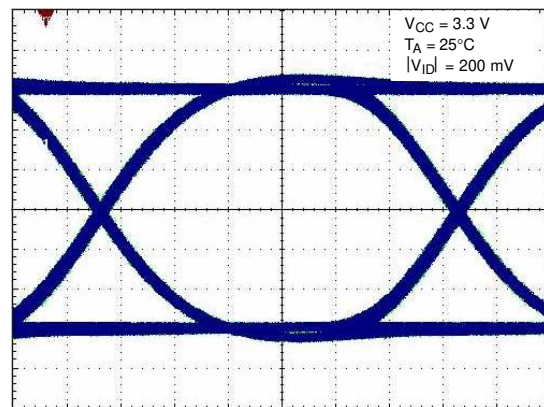

Horizontal Scale= 100 ps/div  
LVPECL-to-LVDS

Figure 19.

TYPICAL CHARACTERISTICS (continued)

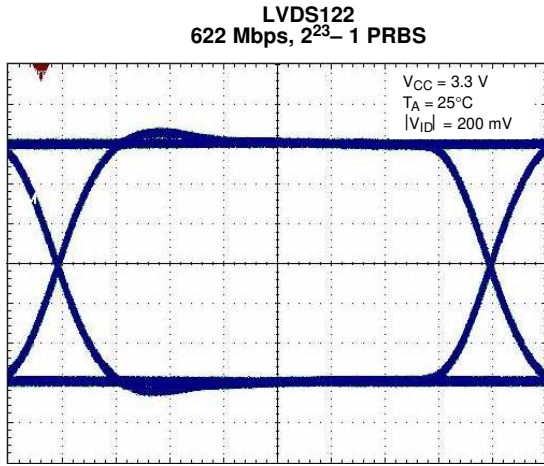

Horizontal Scale= 200 ps/div  
LVDS-to-LVDS

Figure 20.

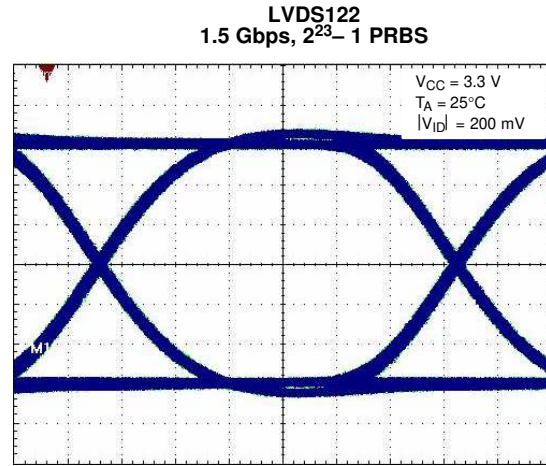

Horizontal Scale= 100 ps/div  
LVDS-to-LVDS

Figure 21.

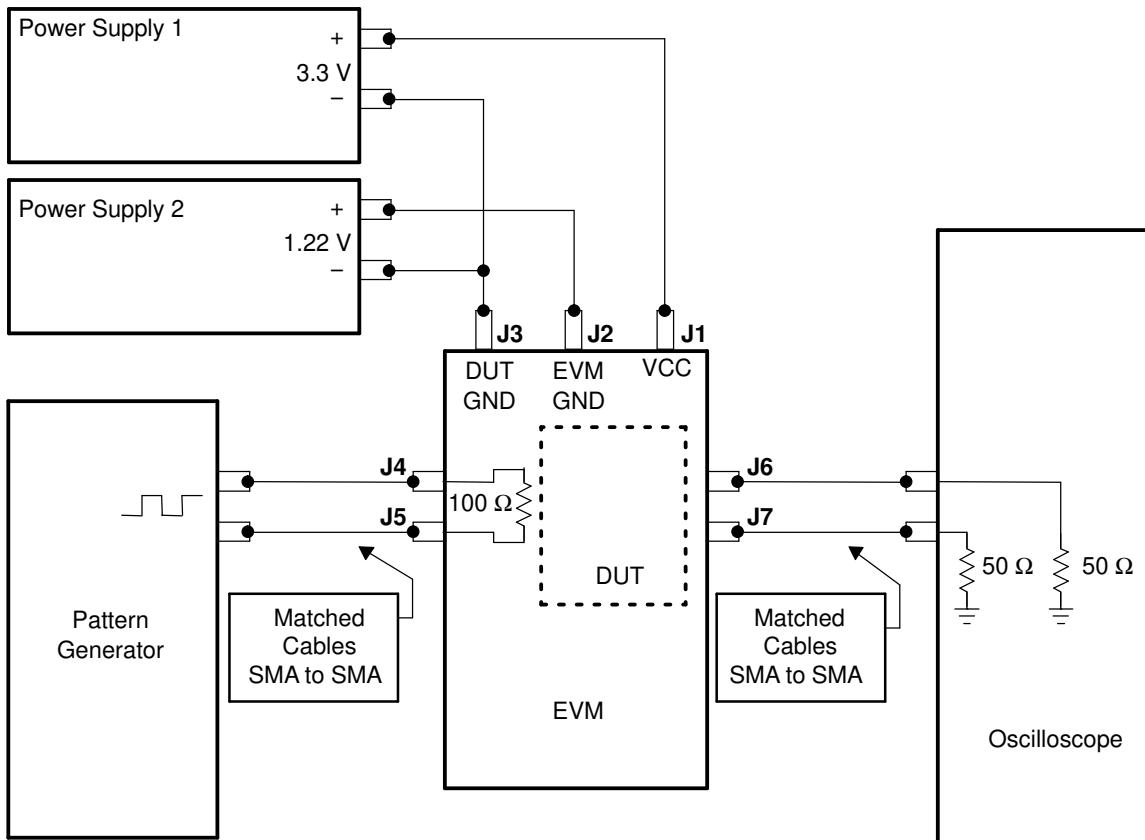

Figure 22. Jitter Setup Connections for SN65LVDS122

## APPLICATION INFORMATION

### TYPICAL APPLICATION CIRCUITS (ECL, PECL, LVDS, etc.)

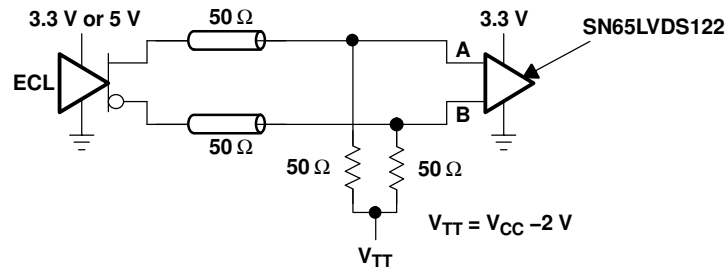

Figure 23. Low-Voltage Positive Emitter-Coupled Logic (LVPECL)

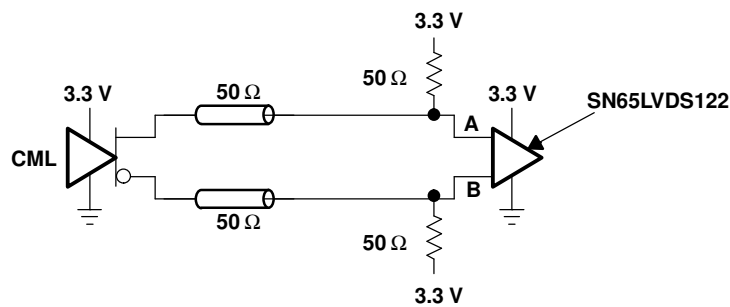

Figure 24. Current-Mode Logic (CML)

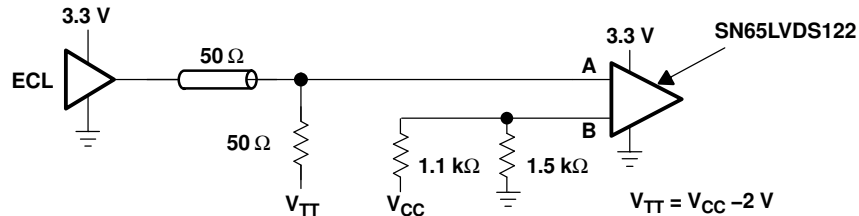

Figure 25. Single-Ended (LVPECL)

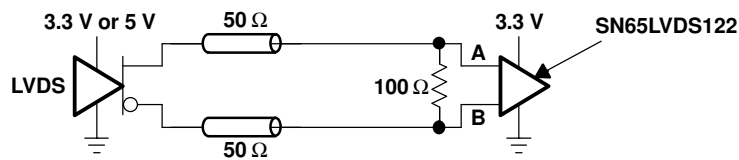

Figure 26. Low-Voltage Differential Signaling (LVDS)

**PACKAGING INFORMATION**

Orderable Device	Status (1)	Package Type	Package Drawing	Pins	Package Qty	Eco Plan (2)	Lead finish/ Ball material (6)	MSL Peak Temp (3)	Op Temp (°C)	Device Marking (4/5)	Samples
SN65LVDS122D	ACTIVE	SOIC	D	16	40	RoHS & Green	NIPDAU	Level-1-260C-UNLIM	-40 to 85	LVDS122	<a href="#">Samples</a>
SN65LVDS122DR	ACTIVE	SOIC	D	16	2500	RoHS & Green	NIPDAU	Level-1-260C-UNLIM	-40 to 85	LVDS122	<a href="#">Samples</a>
SN65LVDS122PW	ACTIVE	TSSOP	PW	16	90	RoHS & Green	NIPDAU	Level-1-260C-UNLIM	-40 to 85	LVDS122	<a href="#">Samples</a>
SN65LVDS122PWR	ACTIVE	TSSOP	PW	16	2000	RoHS & Green	NIPDAU	Level-1-260C-UNLIM	-40 to 85	LVDS122	<a href="#">Samples</a>
SN65LVDT122D	ACTIVE	SOIC	D	16	40	RoHS & Green	NIPDAU	Level-1-260C-UNLIM	-40 to 85	LVDT122	<a href="#">Samples</a>
SN65LVDT122PW	ACTIVE	TSSOP	PW	16	90	RoHS & Green	NIPDAU	Level-1-260C-UNLIM	-40 to 85	LVDT122	<a href="#">Samples</a>
SN65LVDT122PWR	ACTIVE	TSSOP	PW	16	2000	RoHS & Green	NIPDAU	Level-1-260C-UNLIM	-40 to 85	LVDT122	<a href="#">Samples</a>

(1) The marketing status values are defined as follows:

**ACTIVE:** Product device recommended for new designs.

**LIFEBUY:** TI has announced that the device will be discontinued, and a lifetime-buy period is in effect.

**NRND:** Not recommended for new designs. Device is in production to support existing customers, but TI does not recommend using this part in a new design.

**PREVIEW:** Device has been announced but is not in production. Samples may or may not be available.

**OBSOLETE:** TI has discontinued the production of the device.

(2) **RoHS:** TI defines "RoHS" to mean semiconductor products that are compliant with the current EU RoHS requirements for all 10 RoHS substances, including the requirement that RoHS substance do not exceed 0.1% by weight in homogeneous materials. Where designed to be soldered at high temperatures, "RoHS" products are suitable for use in specified lead-free processes. TI may reference these types of products as "Pb-Free".

**RoHS Exempt:** TI defines "RoHS Exempt" to mean products that contain lead but are compliant with EU RoHS pursuant to a specific EU RoHS exemption.

**Green:** TI defines "Green" to mean the content of Chlorine (Cl) and Bromine (Br) based flame retardants meet JS709B low halogen requirements of <=1000ppm threshold. Antimony trioxide based flame retardants must also meet the <=1000ppm threshold requirement.

(3) MSL, Peak Temp. - The Moisture Sensitivity Level rating according to the JEDEC industry standard classifications, and peak solder temperature.

(4) There may be additional marking, which relates to the logo, the lot trace code information, or the environmental category on the device.

(5) Multiple Device Markings will be inside parentheses. Only one Device Marking contained in parentheses and separated by a "~" will appear on a device. If a line is indented then it is a continuation of the previous line and the two combined represent the entire Device Marking for that device.

<sup>(6)</sup> Lead finish/Ball material - Orderable Devices may have multiple material finish options. Finish options are separated by a vertical ruled line. Lead finish/Ball material values may wrap to two lines if the finish value exceeds the maximum column width.

**Important Information and Disclaimer:**The information provided on this page represents TI's knowledge and belief as of the date that it is provided. TI bases its knowledge and belief on information provided by third parties, and makes no representation or warranty as to the accuracy of such information. Efforts are underway to better integrate information from third parties. TI has taken and continues to take reasonable steps to provide representative and accurate information but may not have conducted destructive testing or chemical analysis on incoming materials and chemicals. TI and TI suppliers consider certain information to be proprietary, and thus CAS numbers and other limited information may not be available for release.

In no event shall TI's liability arising out of such information exceed the total purchase price of the TI part(s) at issue in this document sold by TI to Customer on an annual basis.

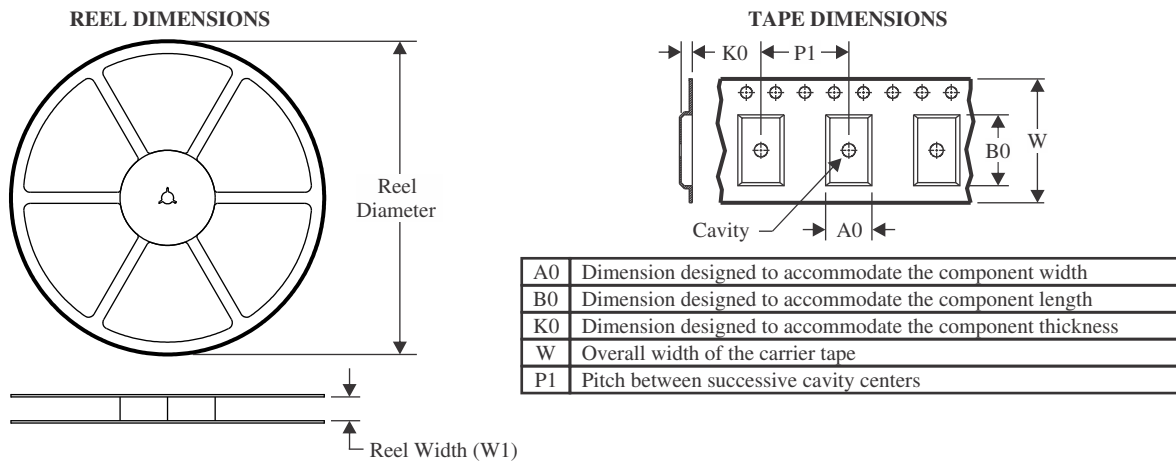
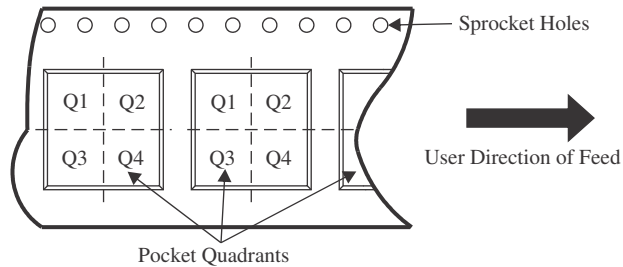
**TAPE AND REEL INFORMATION**

**QUADRANT ASSIGNMENTS FOR PIN 1 ORIENTATION IN TAPE**

\*All dimensions are nominal

Device	Package Type	Package Drawing	Pins	SPQ	Reel Diameter (mm)	Reel Width W1 (mm)	A0 (mm)	B0 (mm)	K0 (mm)	P1 (mm)	W (mm)	Pin1 Quadrant
SN65LVDS122DR	SOIC	D	16	2500	330.0	16.4	6.5	10.3	2.1	8.0	16.0	Q1
SN65LVDS122PWR	TSSOP	PW	16	2000	330.0	12.4	6.9	5.6	1.6	8.0	12.0	Q1
SN65LVDT122PWR	TSSOP	PW	16	2000	330.0	12.4	6.9	5.6	1.6	8.0	12.0	Q1

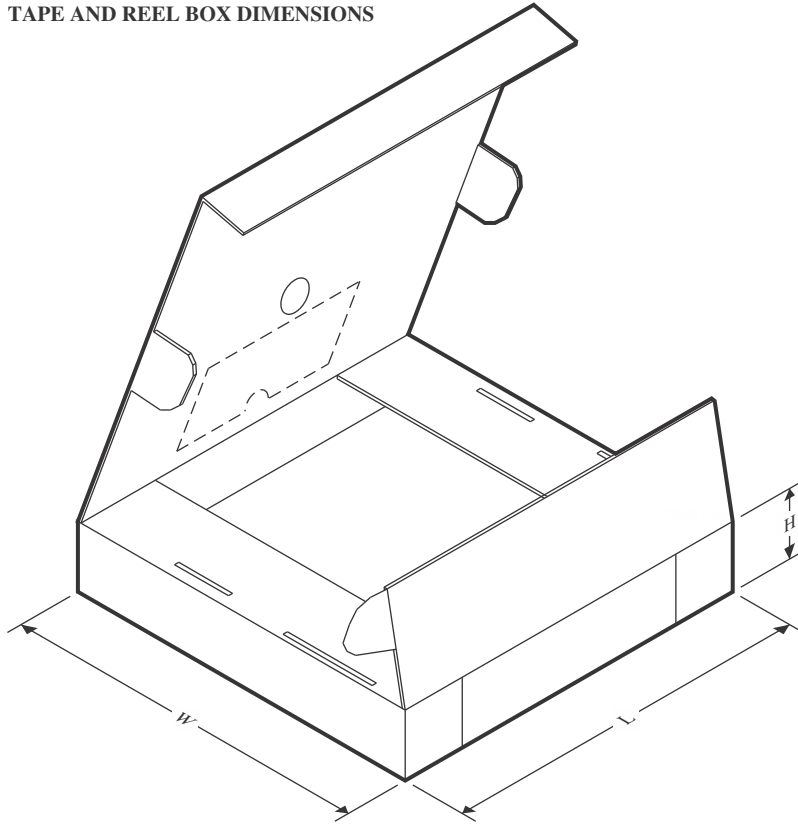

## TAPE AND REEL BOX DIMENSIONS



\*All dimensions are nominal

Device	Package Type	Package Drawing	Pins	SPQ	Length (mm)	Width (mm)	Height (mm)
SN65LVDS122DR	SOIC	D	16	2500	350.0	350.0	43.0
SN65LVDS122PWR	TSSOP	PW	16	2000	350.0	350.0	43.0
SN65LVDT122PWR	TSSOP	PW	16	2000	350.0	350.0	43.0

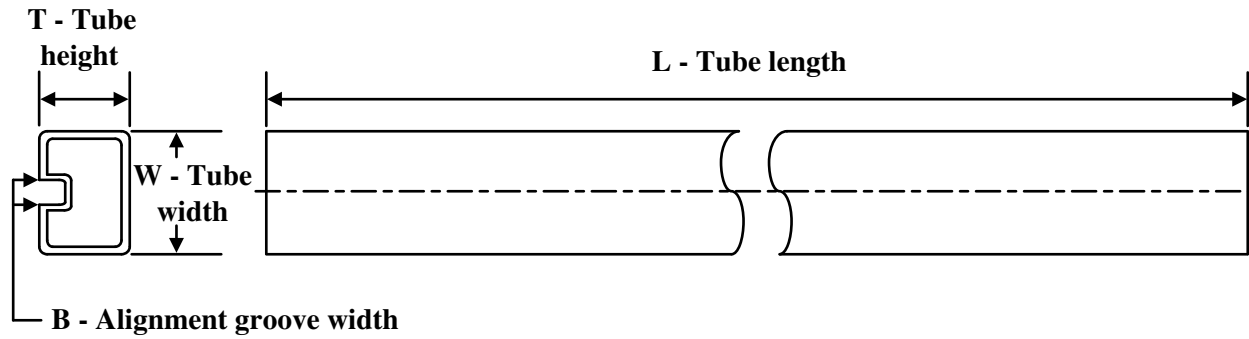
**TUBE**

\*All dimensions are nominal



Device	Package Name	Package Type	Pins	SPQ	L (mm)	W (mm)	T (μm)	B (mm)
SN65LVDS122D	D	SOIC	16	40	505.46	6.76	3810	4
SN65LVDS122PW	PW	TSSOP	16	90	530	10.2	3600	3.5
SN65LVDT122D	D	SOIC	16	40	505.46	6.76	3810	4
SN65LVDT122PW	PW	TSSOP	16	90	530	10.2	3600	3.5

D (R-PDSO-G16)

PLASTIC SMALL OUTLINE



4040047-6/M 06/11

- NOTES:
- A. All linear dimensions are in inches (millimeters).
  - B. This drawing is subject to change without notice.
  -  C. Body length does not include mold flash, protrusions, or gate burrs. Mold flash, protrusions, or gate burrs shall not exceed 0.006 (0,15) each side.
  -  D. Body width does not include interlead flash. Interlead flash shall not exceed 0.017 (0,43) each side.
  - E. Reference JEDEC MS-012 variation AC.

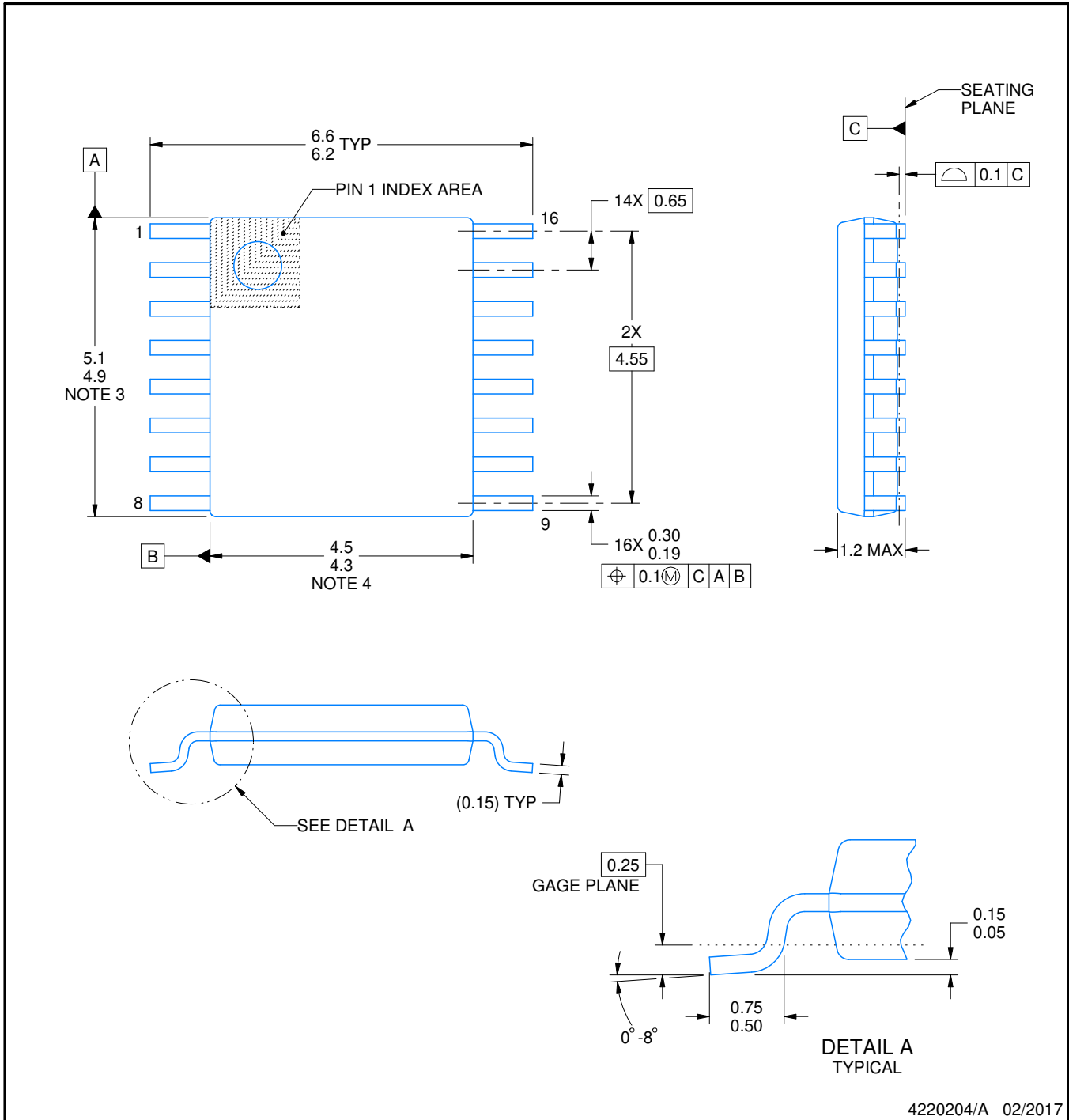

4220204/A 02/2017

NOTES:

1. All linear dimensions are in millimeters. Any dimensions in parenthesis are for reference only. Dimensioning and tolerancing per ASME Y14.5M.
2. This drawing is subject to change without notice.
3. This dimension does not include mold flash, protrusions, or gate burrs. Mold flash, protrusions, or gate burrs shall not exceed 0.15 mm per side.
4. This dimension does not include interlead flash. Interlead flash shall not exceed 0.25 mm per side.
5. Reference JEDEC registration MO-153.

# EXAMPLE BOARD LAYOUT

PW0016A

TSSOP - 1.2 mm max height

SMALL OUTLINE PACKAGE



LAND PATTERN EXAMPLE  
EXPOSED METAL SHOWN  
SCALE: 10X



SOLDER MASK DETAILS

4220204/A 02/2017

NOTES: (continued)

- 6. Publication IPC-7351 may have alternate designs.
- 7. Solder mask tolerances between and around signal pads can vary based on board fabrication site.

# EXAMPLE STENCIL DESIGN

PW0016A

TSSOP - 1.2 mm max height

SMALL OUTLINE PACKAGE

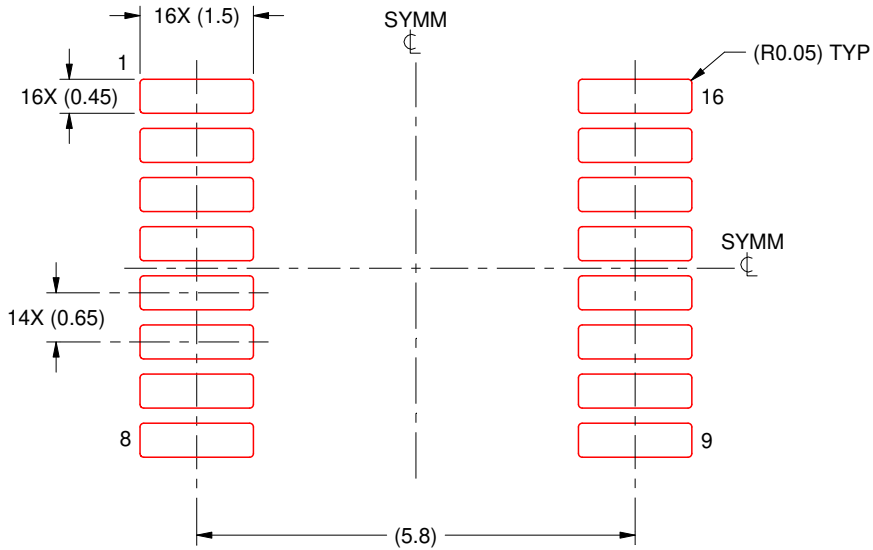

SOLDER PASTE EXAMPLE  
BASED ON 0.125 mm THICK STENCIL  
SCALE: 10X

4220204/A 02/2017

NOTES: (continued)

8. Laser cutting apertures with trapezoidal walls and rounded corners may offer better paste release. IPC-7525 may have alternate design recommendations.
9. Board assembly site may have different recommendations for stencil design.

## IMPORTANT NOTICE AND DISCLAIMER

TI PROVIDES TECHNICAL AND RELIABILITY DATA (INCLUDING DATA SHEETS), DESIGN RESOURCES (INCLUDING REFERENCE DESIGNS), APPLICATION OR OTHER DESIGN ADVICE, WEB TOOLS, SAFETY INFORMATION, AND OTHER RESOURCES "AS IS" AND WITH ALL FAULTS, AND DISCLAIMS ALL WARRANTIES, EXPRESS AND IMPLIED, INCLUDING WITHOUT LIMITATION ANY IMPLIED WARRANTIES OF MERCHANTABILITY, FITNESS FOR A PARTICULAR PURPOSE OR NON-INFRINGEMENT OF THIRD PARTY INTELLECTUAL PROPERTY RIGHTS.

These resources are intended for skilled developers designing with TI products. You are solely responsible for (1) selecting the appropriate TI products for your application, (2) designing, validating and testing your application, and (3) ensuring your application meets applicable standards, and any other safety, security, regulatory or other requirements.

These resources are subject to change without notice. TI grants you permission to use these resources only for development of an application that uses the TI products described in the resource. Other reproduction and display of these resources is prohibited. No license is granted to any other TI intellectual property right or to any third party intellectual property right. TI disclaims responsibility for, and you will fully indemnify TI and its representatives against, any claims, damages, costs, losses, and liabilities arising out of your use of these resources.

TI's products are provided subject to [TI's Terms of Sale](#) or other applicable terms available either on [ti.com](http://ti.com) or provided in conjunction with such TI products. TI's provision of these resources does not expand or otherwise alter TI's applicable warranties or warranty disclaimers for TI products.

TI objects to and rejects any additional or different terms you may have proposed.

Mailing Address: Texas Instruments, Post Office Box 655303, Dallas, Texas 75265  
Copyright © 2022, Texas Instruments Incorporated