

| REV | DATE       | CHANGE DESCRIPTION                        |
|-----|------------|---|
| A   | 2019/03/22 | NEW RELEASE                               |
| B   | 2019/12/02 | UPDATE PRINT TEXT (5.9 CHANGE OF 5.8-8.5) |

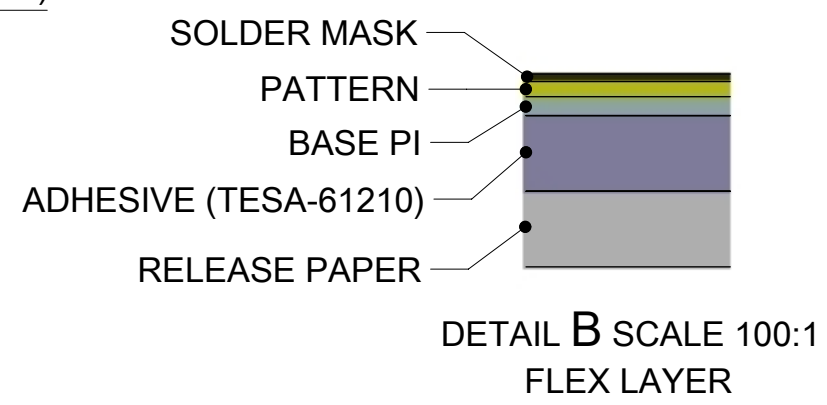
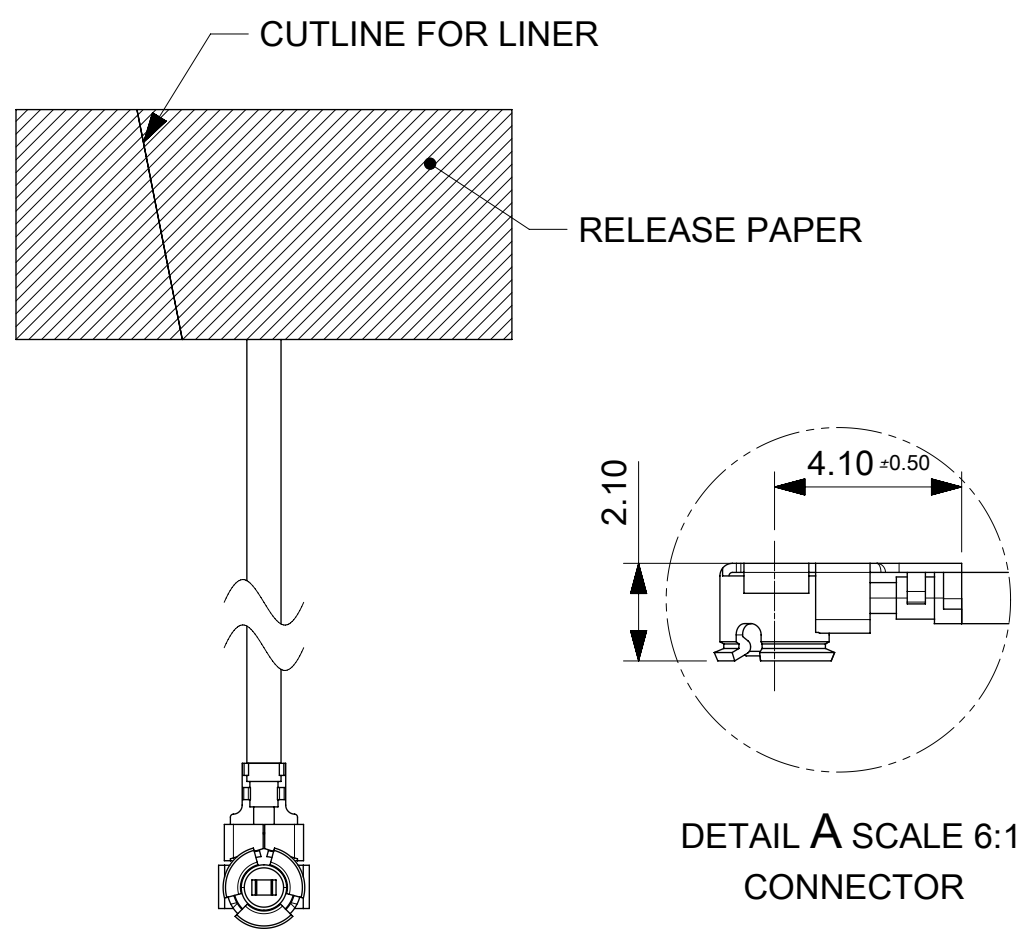
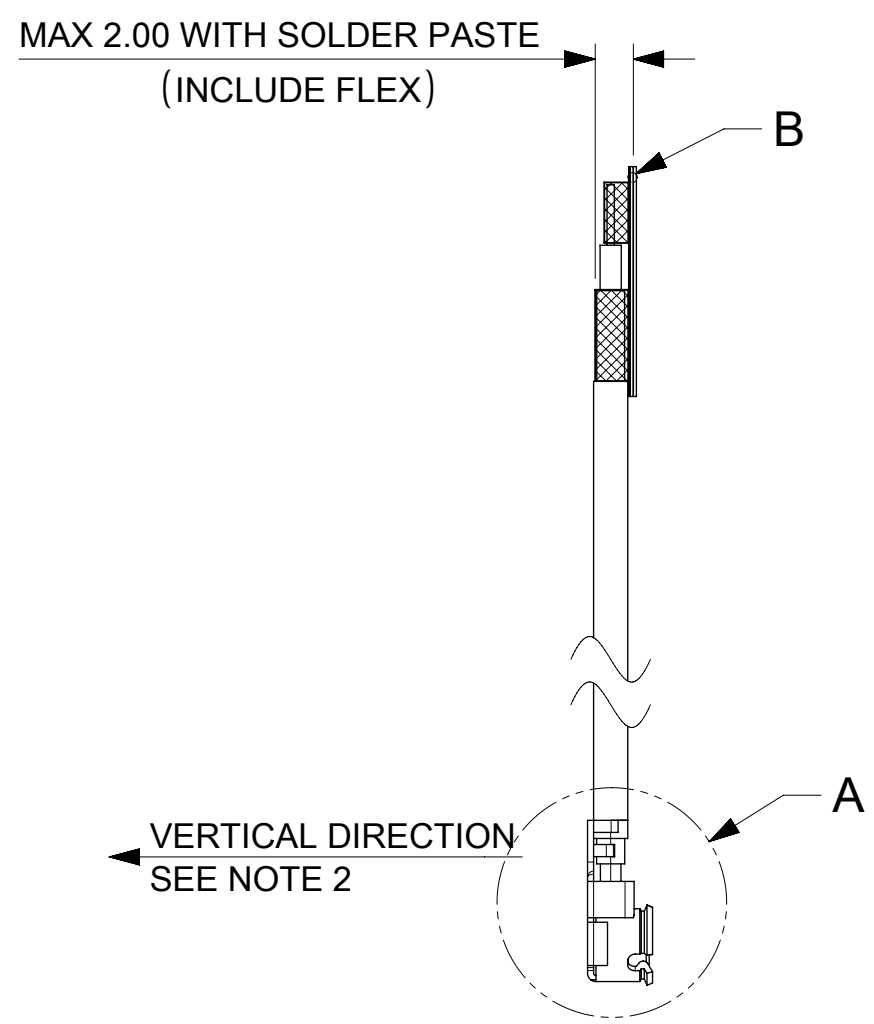
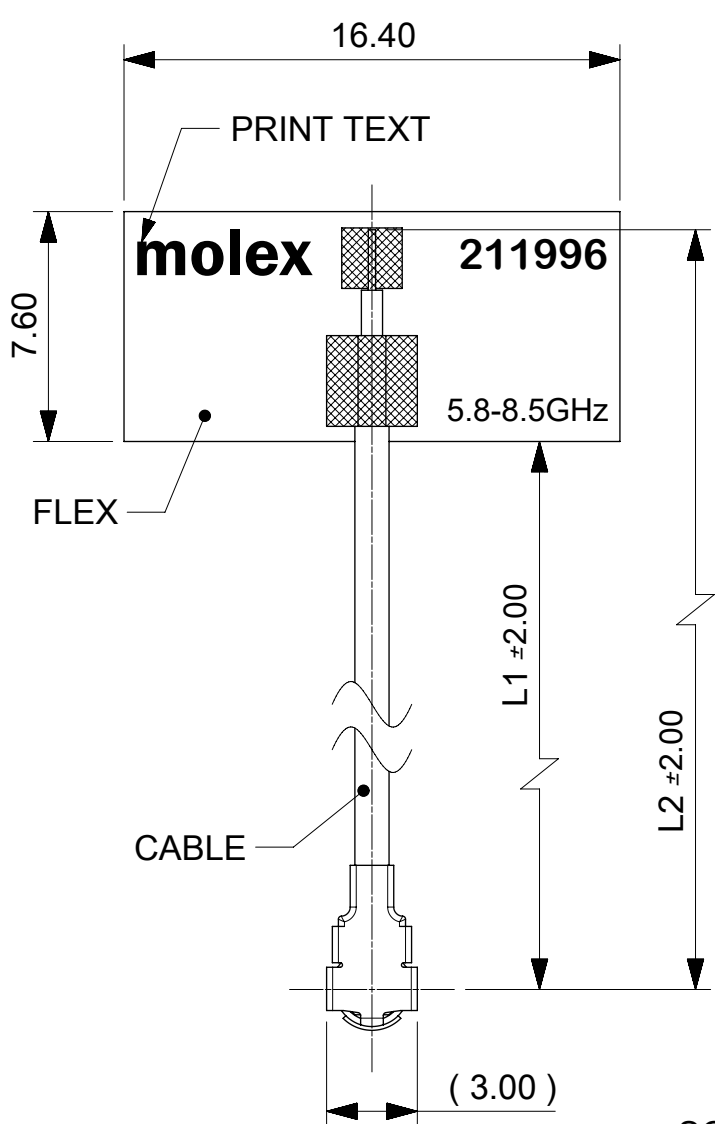

| ITEM | MATERIAL NO. | "L1"-LENGTH | "L2"-LENGTH |
|------|--------------|-------------|-------------|
| 1    | 2119960050   | 43 mm       | 50 mm       |
| 2    | 2119960100   | 93 mm       | 100 mm      |
| 3    | 2119960150   | 143 mm      | 150 mm      |
| 4    | 2119960200   | 193 mm      | 200 mm      |
| 5    | 2119960250   | 243 mm      | 250 mm      |
| 6    | 2119960300   | 293 mm      | 300 mm      |

- NOTES:
- MATERIAL:FLEX SIZE 16.4\*7.6 mm  
CABLE:Ø1.13 mm  
CONNECTOR:OD1.13 RF 2.5H U.FL CONNECTOR-PLUG GOLD PLATED ( IPEX MHF-I COMPATIBLE )
  - FOR PULL TEST, CAN NOT LIFT UP IN THE VERTICAL DIRECTION.
  - SOLDER MASK COLOR:BLACK.
  - PRINT TEXT COLOR:WHITE.
  - ADHESIVE MATERIAL:TESA-61210 100um.
  - THE CONNECTOR WILL BE PROTECTED WITH A CAP

| SYMBOLS  | THIS DRAWING CONTAINS INFORMATION THAT IS PROPRIETARY TO MOLEX ELECTRONIC TECHNOLOGIES, LLC AND SHOULD NOT BE USED WITHOUT WRITTEN PERMISSION | CURRENT REV DESC: |                   | <b>molex</b>    |                |              |   |         |               |                 |                |            |               |            |              |            |                             |     |                   |  |                          |  |
|--|---|-------------------|-------------------|-----------------|----------------|--------------|---|---------|---------------|-----------------|----------------|------------|---------------|------------|--------------|------------|-----------------------------|-----|-------------------|--|--------------------------|--|
|  | <table border="1"> <tr> <th>DIMENSION UNITS</th> <th>SCALE</th> </tr> <tr> <td>mm</td> <td>2:1</td> </tr> </table>                            | DIMENSION UNITS   | SCALE             |                 | mm             | 2:1          | <table border="1"> <tr> <td>EC NO: 626809</td> <td>2019/12/02</td> </tr> <tr> <td>DRWN: KCHENG06</td> <td>2019/12/09</td> </tr> <tr> <td>CHK'D: XJSONG</td> <td>2019/12/09</td> </tr> <tr> <td>APPR: XJSONG</td> <td>2019/12/09</td> </tr> </table> |         | EC NO: 626809 | 2019/12/02      | DRWN: KCHENG06 | 2019/12/09 | CHK'D: XJSONG | 2019/12/09 | APPR: XJSONG | 2019/12/09 | 5.8-8.5GHZ FLEXIBLE ANTENNA |     |                   |  |                          |  |
| DIMENSION UNITS  | SCALE   |                   |                   |                 |                |              |   |         |               |                 |                |            |               |            |              |            |                             |     |                   |  |                          |  |
| mm   | 2:1   |                   |                   |                 |                |              |   |         |               |                 |                |            |               |            |              |            |                             |     |                   |  |                          |  |
| EC NO: 626809  | 2019/12/02  |                   |                   |                 |                |              |   |         |               |                 |                |            |               |            |              |            |                             |     |                   |  |                          |  |
| DRWN: KCHENG06   | 2019/12/09  |                   |                   |                 |                |              |   |         |               |                 |                |            |               |            |              |            |                             |     |                   |  |                          |  |
| CHK'D: XJSONG  | 2019/12/09  |                   |                   |                 |                |              |   |         |               |                 |                |            |               |            |              |            |                             |     |                   |  |                          |  |
| APPR: XJSONG   | 2019/12/09  |                   |                   |                 |                |              |   |         |               |                 |                |            |               |            |              |            |                             |     |                   |  |                          |  |
| <table border="1"> <tr> <th>ANGULAR TOL</th> <th>±</th> <th>'</th> </tr> <tr> <td>4 PLACES</td> <td>±</td> <td>0</td> </tr> <tr> <td>3 PLACES</td> <td>±</td> <td>0.2</td> </tr> <tr> <td>2 PLACES</td> <td>±</td> <td>0.25</td> </tr> <tr> <td>1 PLACE</td> <td>±</td> <td>0.3</td> </tr> <tr> <td>0 PLACES</td> <td>±</td> <td>0.5</td> </tr> </table> | ANGULAR TOL   | ±                 | '                 | 4 PLACES        | ±              | 0            | 3 PLACES  | ±       | 0.2           | 2 PLACES        | ±              | 0.25       | 1 PLACE       | ±          | 0.3          | 0 PLACES   | ±                           | 0.5 | INITIAL REVISION: |  | PRODUCT CUSTOMER DRAWING |  |
| ANGULAR TOL  | ±   | '                 |                   |                 |                |              |   |         |               |                 |                |            |               |            |              |            |                             |     |                   |  |                          |  |
| 4 PLACES   | ±   | 0                 |                   |                 |                |              |   |         |               |                 |                |            |               |            |              |            |                             |     |                   |  |                          |  |
| 3 PLACES   | ±   | 0.2               |                   |                 |                |              |   |         |               |                 |                |            |               |            |              |            |                             |     |                   |  |                          |  |
| 2 PLACES   | ±   | 0.25              |                   |                 |                |              |   |         |               |                 |                |            |               |            |              |            |                             |     |                   |  |                          |  |
| 1 PLACE  | ±   | 0.3               |                   |                 |                |              |   |         |               |                 |                |            |               |            |              |            |                             |     |                   |  |                          |  |
| 0 PLACES   | ±   | 0.5               |                   |                 |                |              |   |         |               |                 |                |            |               |            |              |            |                             |     |                   |  |                          |  |
| <table border="1"> <tr> <th>DRAFT WHERE APPLICABLE</th> <th>MUST REMAIN</th> <th>WITHIN DIMENSIONS</th> </tr> <tr> <td>☐</td> <td>☐</td> <td>☐</td> </tr> </table>   | DRAFT WHERE APPLICABLE  | MUST REMAIN       | WITHIN DIMENSIONS | ☐               | ☐              | ☐            | THIRD ANGLE PROJECTION  | DRAWING | SERIES        | DOCUMENT NUMBER | DOC TYPE       | DOC PART   | REVISION      |            |              |            |                             |     |                   |  |                          |  |
| DRAFT WHERE APPLICABLE   | MUST REMAIN   | WITHIN DIMENSIONS |                   |                 |                |              |   |         |               |                 |                |            |               |            |              |            |                             |     |                   |  |                          |  |
| ☐  | ☐   | ☐                 |                   |                 |                |              |   |         |               |                 |                |            |               |            |              |            |                             |     |                   |  |                          |  |
|  | ☉   | A3-SIZE           | 211996            | 2119960100      | PSD            | 000          | B   |         |               |                 |                |            |               |            |              |            |                             |     |                   |  |                          |  |
|  |   |                   |                   | MATERIAL NUMBER | CUSTOMER       | SHEET NUMBER |   |         |               |                 |                |            |               |            |              |            |                             |     |                   |  |                          |  |
|  |   |                   |                   | 2119960100      | GENERAL MARKET | 1 OF 1       |   |         |               |                 |                |            |               |            |              |            |                             |     |                   |  |                          |  |