



SPECIFICATION SHEET

SPECIFICATION SHEET NO.	N0820-DC450K0000S024
DATE	Aug. 20, 2021
REVISION	A0
DESCRIPTION	<p>KHz SMD Discriminators 6260 Type L6.2*W6.0*H3.1mm 2 Pads CDBC Series 450.0KHz, Demodulated Bandwidth(3dB): ±4.0KHz Min from 450KHz Operating Temp. Range -20°C ~+80°C Reflow Profile Condition 260 °C Max. In Tape/Reel, 2000pcs/Reel RoHS III Complaint</p>
CUSTOMER	
CUSTOMER PART NUMBER	
CROSS REF. PART NUMBER	
ORIGINAL PART NUMBER	TGS CDBC 450C24 TLF
PART CODE	DC450K0000S024

VENDOR APPROVE		
Issued/Checked/Approved		
		
DATE: Aug. 20, 2021		

CUSTOMER APPROVE	
DATE:	

KHZ SMD CERAMIC DISCRIMINATOR CDBC SERIES

MAIN FEATURE

- KHz SMD Ceramic Discriminator 6260 Type 2 pads
- White case, L6.2*W6.0*H3.1mm
- Low cost and short shipment
- Reflow Profile Condition 260 °C Max.
- Cross main competitors parts CDBC and JTC series
- RoHS/RoHS III compliant
- For quadrature detection with IC: TOSHIBA/TA31136



APPLICATION

- Communication Electronics

PART CODE GUIDE

RFQ
Request For Quotation

DC	450K0000	S	024
1	2	3	4

- 1) DC: Part family Code for KHz SMD Ceramic Discriminator 6260 Type L6.2*W6.0*H3.1mm 2 Pads
- 2) 450K0000: Frequency range code for 450.0000KHz
- 3) S: SMD type, Package Tape/Reel, 2000pcs/Reel
- 4) 024: Specification code for original part No.: **TGS CDBC 450C24 TLF**

KHZ SMD CERAMIC DISCRIMINATOR CDBC SERIES

DIMENSION (Unit: mm)

Image for reference

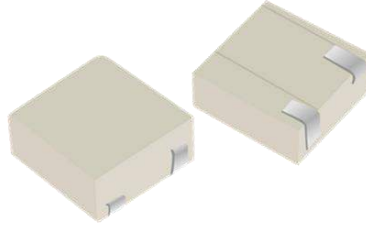

CDBC

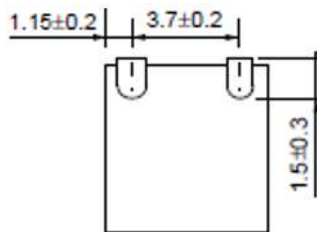
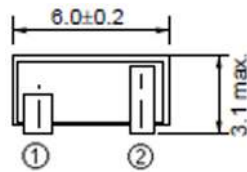
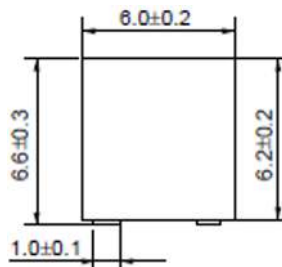

Marking

Line 1: Series Code
Line 2: Frequency Range
+Internal Code

Connection

Pin 1: Input
Pin 2: Output

Measuring Circuit

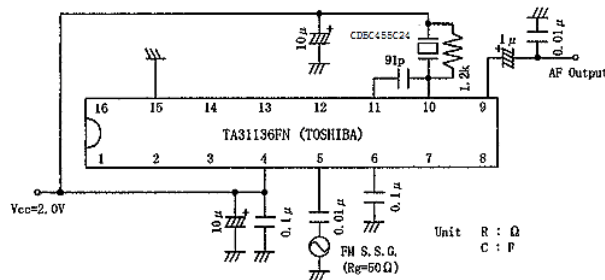

KHZ SMD CERAMIC DISCRIMINATOR CDBC SERIES

ELECTRICAL PARAMETERS

Parameter	Part No. Symbol	Units	Value			Condition
			Min.	Typical	Max.	
Original Manufacturer	TGS	TGS Crystals				
Holder Type	CDBC	KHz SMD Discriminators 6260 Type L6.2*W6.0*H3.1mm 2 Pads				
Frequency Range (f0)	450	KHz	450.000		@ ± 1.0KHz	
Bandwidth	C24	KHz	±4.0		@3dB Bandwidth, f0	
Operation Temperature		°C	-20		+80	
Storage Temperature		°C	-40		+85	
Demodulated Output		mV		100±40		@f0
Demodulated Distortion Factor		%			2.0	@ 450KHz
Temperature Stability		%	0.3			@-20 ~+80 °C
IC Model No.		TOSHIBA/TA31136				
Withstand Voltage		DC 5.0V 1 minute				
Other		Package	T	Tape/Reel, 2000pcs/Reel		
	RoHS Status	LF	RoHS III compliant			
	Add Value		N/A			
	Special Code		For Internal Control, Blank: N/A			

Note: Original Part Number: **TGS CDBC 450C24 TLF**

INPUT SIGNAL CONDITION

Item	Unit	Value
Input	dBμ	-80.0
Deviation	KHz	±4.0
Frequency Modulation	KHz	1.0

KHZ SMD CERAMIC DISCRIMINATOR CDBC SERIES

TEST METHOD

Test Items	Test Method And Conditions	Requirement
Demodulated 3dB Bandwidth	<p>Input the above signal and sweep the carrier around 455 kHz, and find Out the maximum audio output frequency. Then sweep the carrier frequency again and find two frequencies, which are observed –3dB attenuation points from the maximum point.</p> <p>Higher frequency point is called (f1) and lower called (f2). (F1-455KHz) is defined as upper 3dB bandwidth and (455KHz-f2) defined as lower 3dB bandwidth.</p>	It shall meet the specification
Demodulate Output	Demodulated output shall be measured when carrier frequency is adjusted to 455KHz.	It shall meet the specification
Demodulated Distortion Factor	Carrier frequency is adjusted to 455KHz.And distortion shall be measured with 1 kHz modulation frequency.	It shall meet the specification
Input signal condition	<p>Input signal condition, Input level - 80dBμ;</p> <p>Frequency Deviation – 4.0KHz; Modulation Frequency: 1.0KHz</p>	
Measurement Condition	<p>Unless otherwise noted, the standard range of atmospheric conditions for measurements and tests are as follows:</p> <p>Ambient temperature:5°C to 35 °C Relative humidity :45% to 85%</p> <p>Air pressure :86Kpa to 106 Kpa</p> <p>If there is doubt about the results, measurement shall be made within the following limits:</p> <p>Ambient temperature: 18°C to 22 °C</p> <p>Relative humidity :60% to 70%</p> <p>Air pressure: 86Kpa to 106 Kpa</p>	

KHZ SMD CERAMIC DISCRIMINATOR CDBC SERIES

RELIABILITY

Test Items	Test Method And Conditions	Requirement
Humidity	After being placed in a chamber with 90-95% R.H. at 40±2°C for 100 hours and then being placed in room temperature for 1 hour, filter shall be measured.	It shall meet Table 1.
High Temperature	After being placed in a chamber with 80±2 °C, for 100 hours and then being placed in room temperature for 1 hour, filter shall be measured.	It shall meet Table 1.
Low Temperature	After being placed in a chamber with -20±2 °C, for 100 hours and then being placed in room temperature for 1 hour, filter shall be measured.	It shall meet Table 1.
Heat Shock	After being kept at room temperature, filter shall be placed at temperature of -55 °C , for 30 minutes, then be placed at temperature. 85 °C, for 30 minutes. After that returned to -55 °C again. Repeated above cycle for 5 times. After being kept in room temp. for 1 hour, filter shall be measured	It shall meet Table 1.
Resistance to Solder Heat	Lead terminals are immersed up to 1.5mm from filter’s body in soldering bath of 350± 10°C, for 3±0.5 sec. And then filter shall be measured after being placed in room temperature for 1 hour.	It shall meet Table 1.
Solderability	Lead terminals are immersed in aide solder for 5 sec and then immersed in soldering bath of 230±5°C, for 3±0.5 sec. At least 95% lead terminals shall be covered with solder	It shall meet Table 1.
Drop Test	Filter shall be measured after 3 times random drops from the height of 30 cm on concrete floor	No visible damage and it meet Table 1
Adhesion	A static load of 20N to the direction of the arrow (see Fig. 4) shall be applied on the core of the Component and hold for 10 seconds. Filter shall be soldered correctly and tightly to PCB.	It shall meet Table 1.
Vibration	Filter shall be measured after being applied vibration of amplitude of 1.5mm with 10-55Hz band of vibration frequency to each of 3 perpendicular directions for 2 hours	No visible damage and it meet Table 1
Substrate Bending Test	Apply pressure in the direction of arrow (see Fig. 3) at a rate of about 0.5mm per second until it reaches a bend of 3mm and hold for 30 seconds.	It shall meet Table 1.

Table1

Item	Center Frequency	Demodulated Bandwidth(3dB)	Demodulated Output (at 450 kHz)	Demodulated Distortion
Specification	450±1.0KHz Max.	±4.0KHz Min.	100±40mV.	2.0%Max.

KHZ SMD CERAMIC DISCRIMINATOR CDBC SERIES

SUGGESTED REFLOW PROFILE (For Reference Only)

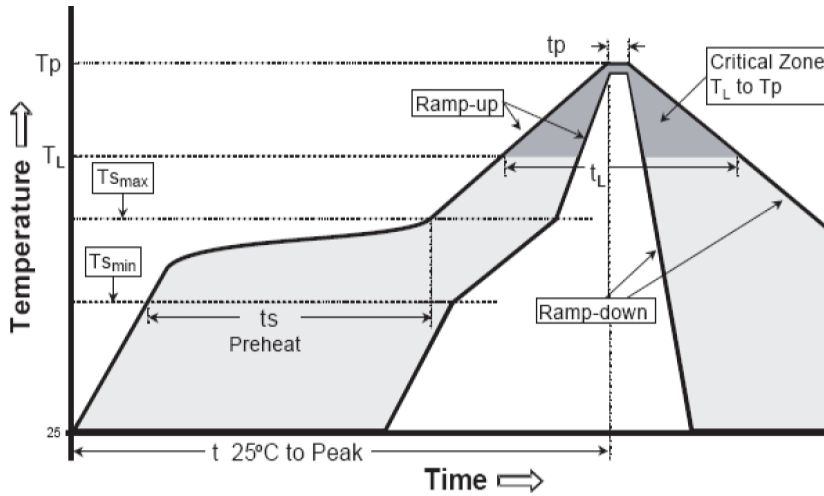

Profile Feature		Pb-Free Assembly
Average Ramp-up Rate (Ts Max to Tp)		3°C/second Max
Preheat	Temperature Min (Ts Min.)	125°C
	Temperature Max (Ts Max.)	200°C
	Time (ts Min. to ts Max.)	60 ~ 180 seconds
Time maintained above	Temperature (T_L)	217°C
	Time (t_L)	60 ~ 150 seconds
Peak/Classification Temperature (T_p)		260 °C
Time within 5°C of actual Peak Temperature (t_p)		20 ~ 40 seconds
Ramp-down rate		6 °C /Second Max.
Time 25 °C to Peak Temperature		8 minutes Max.
Suggest reflow times		3 Times Max.

KHZ SMD CERAMIC DISCRIMINATOR CDBC SERIES

REEL DIMENSION (Unit: mm, 2000pcs/Reel)

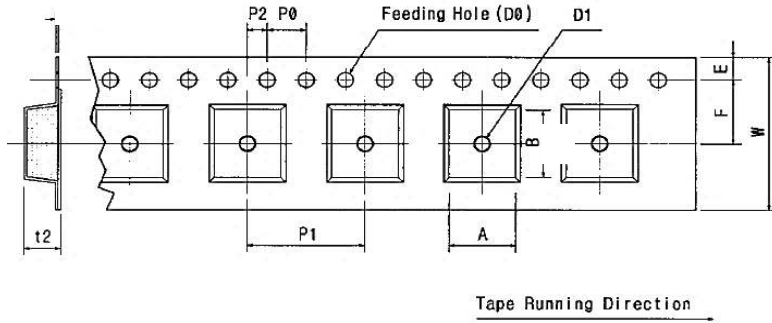

Code	Dimension
W	16.0+/-0.30
F	6.80+/-0.20
E	1.75+/-0.10
P 0	4.00+/-0.10
P 1	7.80+/-0.10
P 2	2.00+/-0.05
D 0	Ø1.5+/-0.10
D 1	Ø1.5+/-0.10
t 2	3.60+/-0.10
A	7.70+/-0.10

TAPE DIMENSION (Unit: mm)

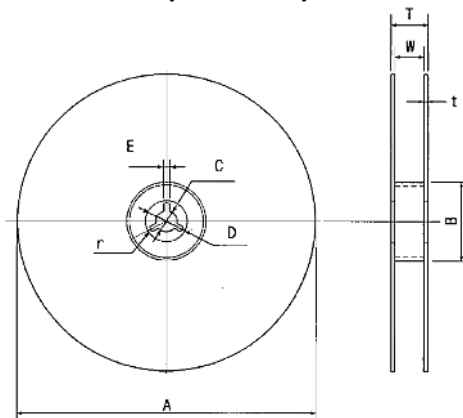

Code	Dimension
A	Ø330+/-1.0
B	Ø80.0+/-0.5
C	Ø13.0+/-0.5
E	2.00+/-0.3
W	16.0+/-1.0

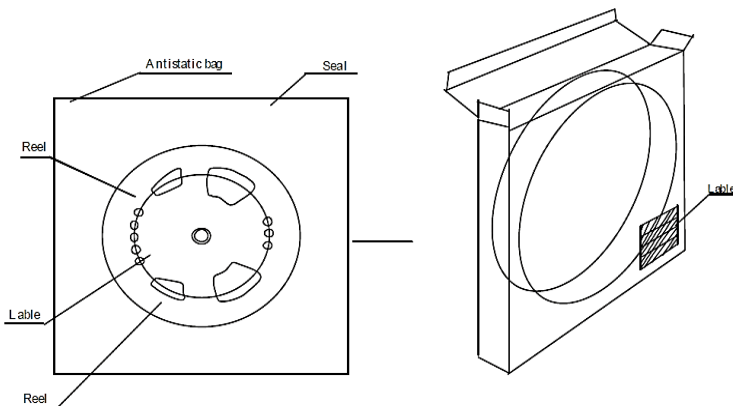

DISCLAIMER

NextGen Components, Inc. reserves the right to make changes to the product(s) and or information contained herein without notice. No liability is assumed as a result of their use or application. No rights under any patent accompany the sale of any such product(s) or information