

THIS DRAWING IS UNPUBLISHED. RELEASED FOR PUBLICATION, 19 .
 © COPYRIGHT 19 BY AMP INCORPORATED. ALL INTERNATIONAL RIGHTS RESERVED.

LOC AF	DIST 50	P	F	REVISIONS			DATE	APPD
				ZONE	LTR	DESCRIPTION		
					C	REV PER 0G3A-0086-00	21FEB00	JR/DD

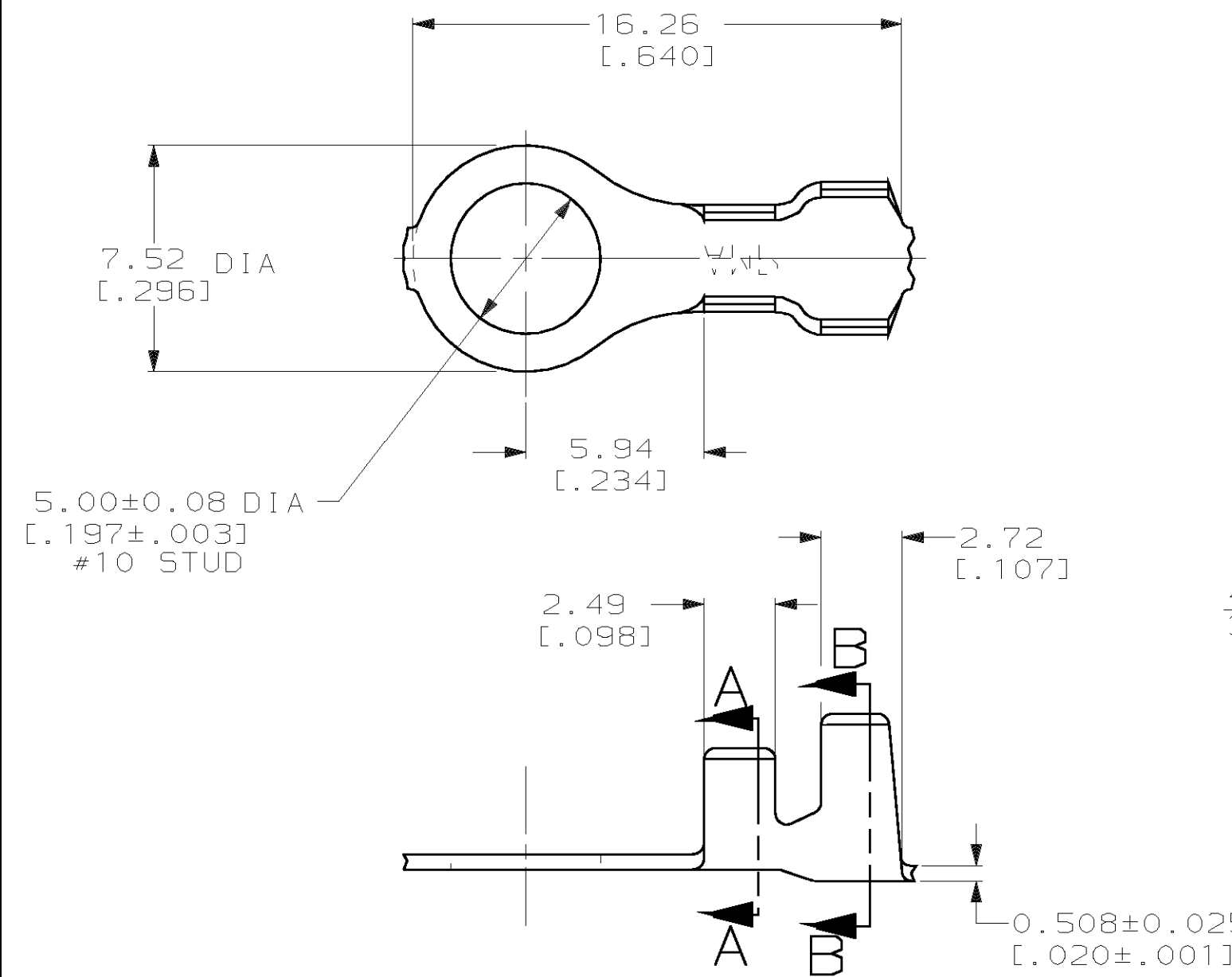

- 1 CONTINUOUS STRIP ON REEL.
- 2 0.003302 [0.000130] MAX PRE-TIN PL PER MIL-T-10727.

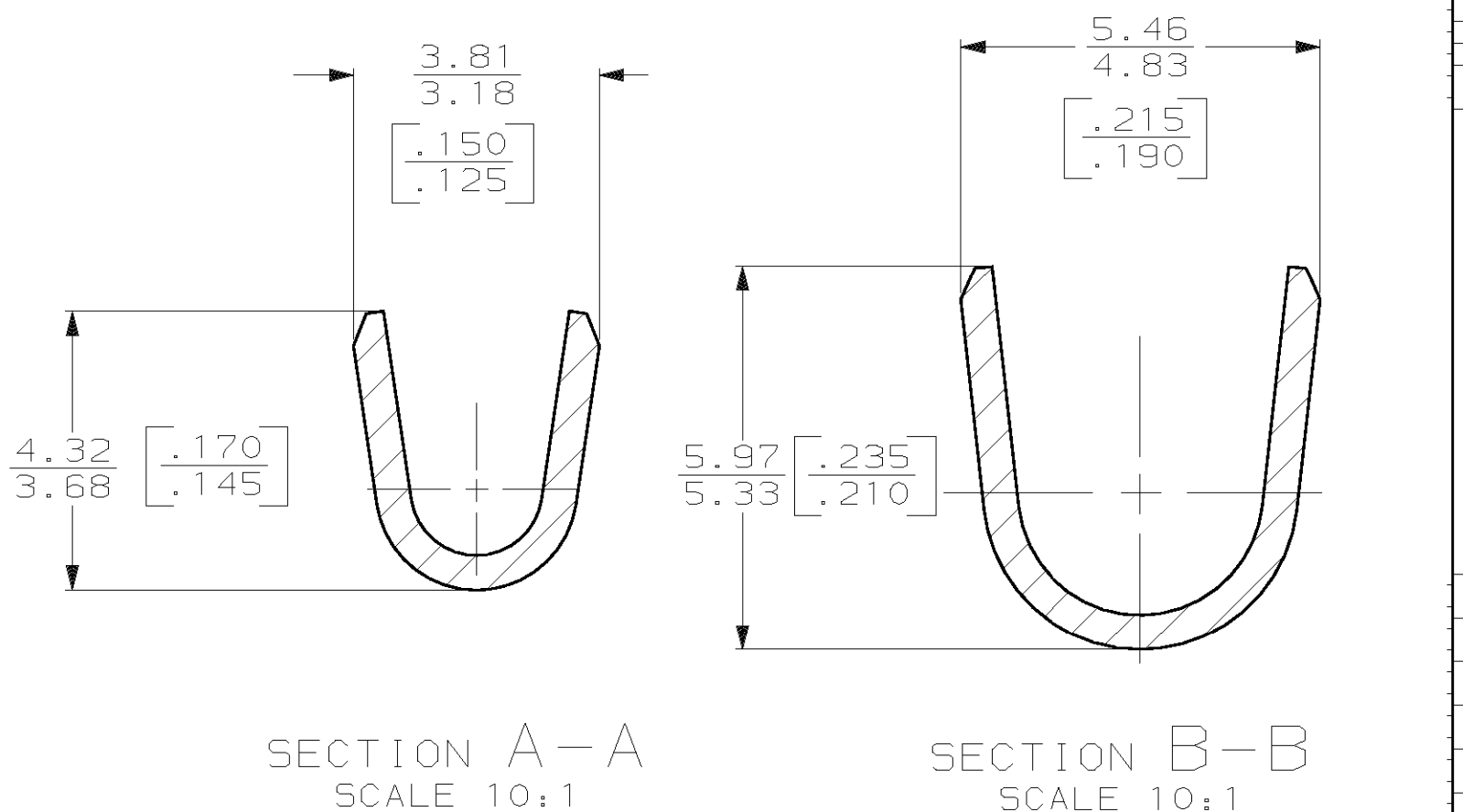

	3.05-4.32 DIA [0.120-.170]	0.8-2.0mm ² [18-14] AWG OR TWO [18'S]	63628-2
			63628-1
FINISH	INSULATION RANGE	WIRE RANGE	PART NO

F OR 0	4.57 [0.180]	4.06 [0.160]	F	3.05 [0.120]	1.93 [0.076]	0.8mm ² [18'S]
					2.03 [0.080]	2.0mm ² [14]
					1.83 [0.072]	1.3mm ² [16]
					1.70 [0.067]	0.8mm ² [18]
TYPE	WIDTH	STRIP LENGTH ±0.38 [±.015]	TYPE	WIDTH	HEIGHT	WIRE
INSUL BARREL CRIMP			WIRE BARREL CRIMP			

DO NOT SCALE PRINT. UNLESS SPECIFIED DIMENSIONS IN mm [INCHES] TOLERANCES ON:
 2 PLC DEC ± 0.25 [0.010]
 3 PLC DEC ± -
 ANGLES ± -

MATERIAL: 082 BRASS
 FINISH: SEE TABLE

DR 11/12/91 P FORTNEY
 CHK 11/12/91 MS FEHER
 APPD 11/12/91 G YETTER
 APPD 11/12/91 R WEAVILL
 PRODUCT SPEC -
 APPLICATION SPEC -
 WEIGHT -

AMP AMP Incorporated
 Harrisburg, PA 17105-3608

NAME: RING

SIZE: B CAGE CODE: 00779 DRAWING NO: 63628
 SCALE: 5:1 SHEET: 1 OF 1