

DRAWING MADE IN THIRD ANGLE PROJECTION

THIS DRAWING IS UNPUBLISHED. RELEASED FOR PUBLICATION ,19 .
 © COPYRIGHT 19 BY AMP INCORPORATED. ALL INTERNATIONAL RIGHTS RESERVED.

LOC	DIST	P	F	REVISIONS			
ZONE	LTR	DESCRIPTION	DATE	APPD			
AF	50			D1	REVISED PER ECR-20-009164	27JUL2020	MK/DH

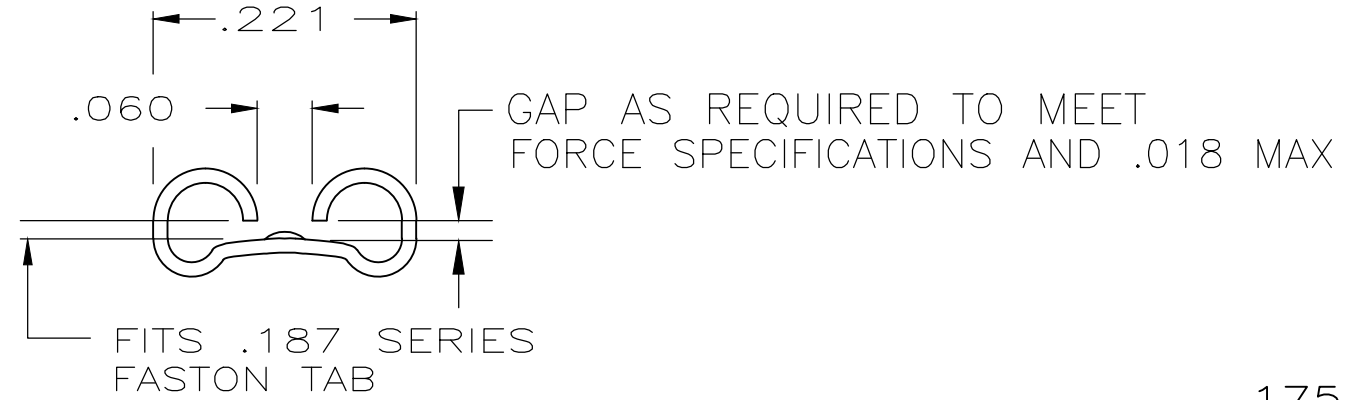
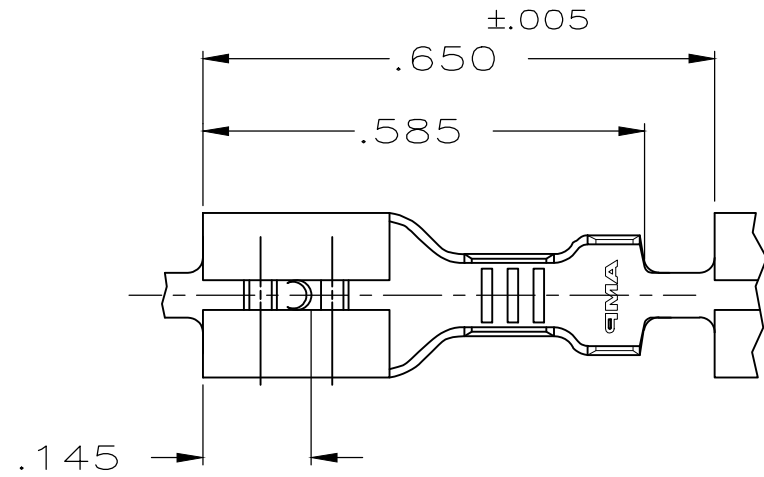

1 - CONTINUOUS STRIP ON REELS.

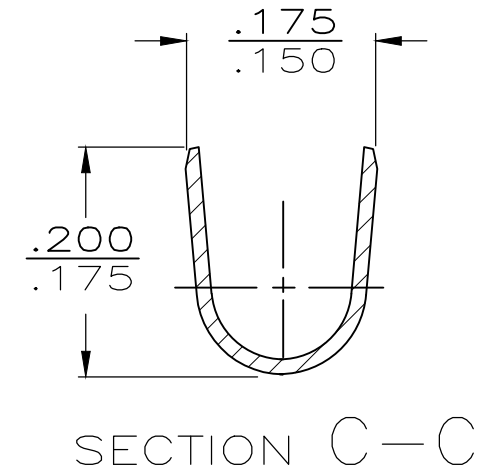
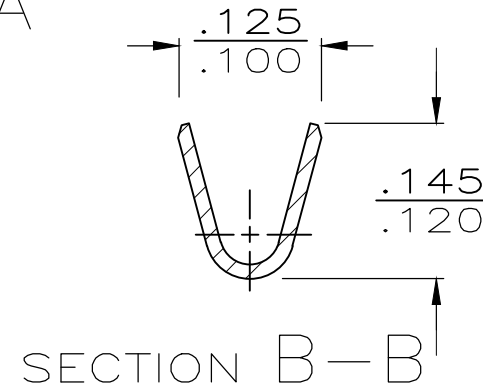
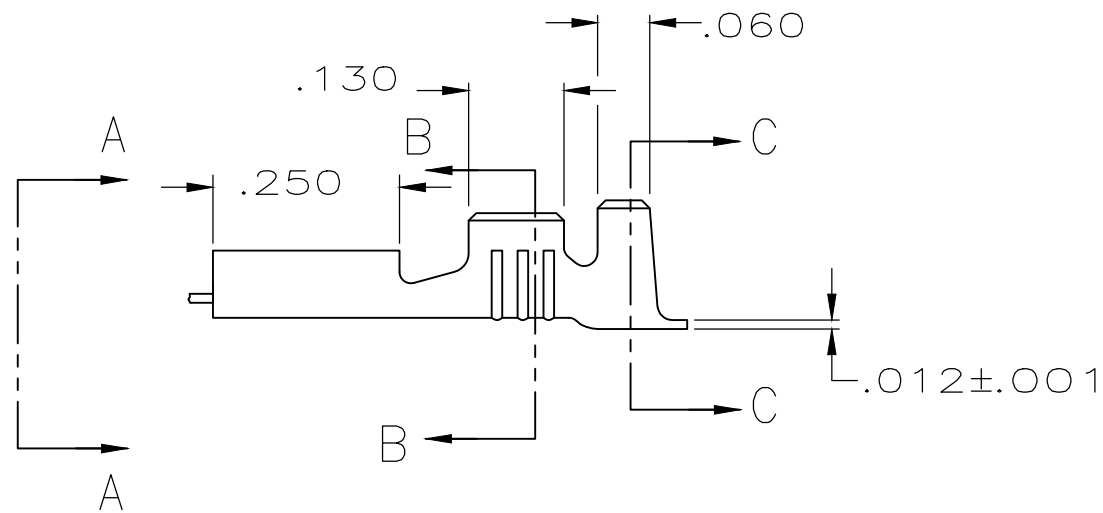

THIS DRAWING IS A CONTROLLED DOCUMENT FOR AMP INCORPORATED. IT IS SUBJECT TO CHANGE AND THE CONTROLLING ENGINEERING ORGANIZATION SHOULD BE CONTACTED FOR THE LATEST REVISION.

.090-.130 DIA	#20-#16 AWG	.021-.019	60621-1
INSULATION RANGE	WIRE SIZE	MATING TAB THICKNESS	PART NO
DO NOT SCALE PRINT. UNLESS SPECIFIED DIMENSIONS IN INCHES TOLERANCES ON: 2 PLC DEC ± - 3 PLC DEC ± .015 ANGLES ± -	DR 4/3/95 JR RUTH CHK 4/3/95 MS FEHER APPD 4/3/95 P DESANTIS APPD 4/3/95 R REINER PRODUCT SPEC -		
MATERIAL T2 STEEL	FINISH NICKEL	NAME RECEPTACLE, FASTON, .187 SERIES	
	APPLICATION SPEC 114-2036	SIZE B	CAGE CODE 00779
	WEIGHT -	DRAWING NO C-60621	SCALE 4:1
		SHEET	1 OF 1