

PQ1Uxx1M2ZPH Series

Low Output Current, Compact Surface Mount Type
Low Power-Loss Voltage Regulators

Features

1. Compact surface mount package (2.9×1.6×1.1mm)
2. Low power-loss
(Dropout voltage: TYP. 0.11 V at I_o=60mA)
3. High ripple rejection (TYP. 70dB)
4. Built-in ON/OFF control function
(Dissipation current at OFF-state: MAX. 1μA)
5. Built-in overcurrent, overheat protection functions
*It is available for every 0.1V of output voltage (1.3V to 5.0V)
6. RoHS directive compliant

Applications

1. Cellular phones
2. Cordless phones
3. Personal information tools (PDA)
4. Cameras/Camcoders
5. PCMCIA cards for notebook PCs

Model Line-up

Output Voltage (TYP.)	Model No.	Output Voltage (TYP.)	Model No.
1.8V	PQ1U181M2ZPH	3.5V	PQ1U351M2ZPH
2.5V	PQ1U251M2ZPH	5.0V	PQ1U501M2ZPH
2.8V	PQ1U281M2ZPH		
3.0V	PQ1U301M2ZPH		
3.3V	PQ1U331M2ZPH		

Absolute Maximum Ratings

(T_a=25°C)

Parameter	Symbol	Rating	Unit
*1 Input voltage	V _{IN}	16	V
*1 ON/OFF control terminal voltage	V _C	16	V
Output current	I _o	300	mA
*2 Power dissipation	P _D	350	mW
*3 Junction temperature	T _j	150	°C
Operating temperature	T _{opr}	-30 to +85	°C
Storage temperature	T _{stg}	-55 to +150	°C
Soldering temperature	T _{sol}	270(10s)	°C

- *1 All are open except GND and applicable terminals.
*2 At mounted on PCB
*3 Overheat protection may operate at T_j=125°C to 150°C

Outline Dimensions

(Unit : mm)

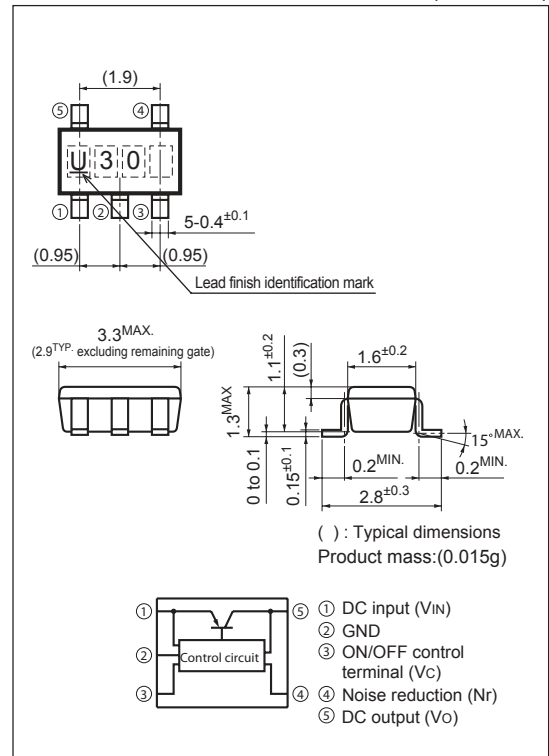

Lead finish: Lead-free solder plating
(Composition: Sn2Cu)

Notice The content of data sheet is subject to change without prior notice.

In the absence of confirmation by device specification sheets, SHARP takes no responsibility for any defects that may occur in equipment using any SHARP devices shown in catalogs, data books, etc. Contact SHARP in order to obtain the latest device specification sheets before using any SHARP device.

Electrical Characteristics

(Unless otherwise specified, $V_{IN}=V_O(TYP) + 1.0V$, $I_o=30mA$, $V_c=1.8V$, $T_a=25^\circ C$)

Parameter	Symbol	Conditions	MIN.	TYP.	MAX.	Unit
Output voltage	V_o	-	Refer to the following table.1			V
*4 Output peak current	I_{op}	-	180	300	-	mA
Recommended output current	-	-	-	-	150	mA
Load regulation	RegL1	$I_o=5$ to 60mA	-	10	50	mV
	RegL2	$I_o=5$ to 100mA	-	20	100	mV
	RegL3	$I_o=5$ to 150mA	-	30	160	mV
Line regulation	RegL	$V_{IN}=V_o(TYP)+1V$ to $V_o(TYP)+6V$	-	3.0	20	mV
Temperature coefficient of output voltage	$T_C V_o$	$I_o=10mA$, $T_j=-25$ to $+75^\circ C$	-	0.05	-	mV/ $^\circ C$
Ripple rejection	RR	Refer to Fig.2	-	70	-	dB
Output noise voltage	$V_{no}(rms)$	$10Hz < f < 100kHz$, $C_n=0.1\mu F$, $I_o=30mA$	Refer to the following table.2			μV
*8 Dropout voltage	V_{I-o1}	$I_o=60mA$ *5	-	0.11	0.26	V
	V_{I-o2}	$I_o=150mA$ *5	-	0.20	0.4	
*6 ON-state voltage for control	$V_{C(ON)}$	-	1.8	-	-	V
ON-state current for control	$I_{C(ON)}$	$V_c=1.8V$	-	5	30	μA
OFF-state voltage for control	$V_{C(OFF)}$	-	-	-	0.4	V
Quiescent current	I_q	$I_o=0mA$	-	130	200	μA
Output OFF-state dissipation current	I_{qs}	$V_c=0.2V$	-	-	1	μA

- *4 Output current shall be the value when output voltage lowers 0.3V from the voltage at $I_o=30mA$.
- *5 Input voltage when output voltage falls 0.1V from that at $V_{IN}=V_o(TYP)+1.0V$.
- *6 In case that the control terminal (③ pin) is open, output voltage should be OFF state.
- *7 In case of **PQ1U181M2ZPH**, V_{IN} minimum=2.3V.
- *8 Excluding **PQ1U181M2ZPH**

Table.1 Output Voltage

($V_{IN}=V_o(TYP)+1.0V$, $I_o=30mA$, $V_c=1.8V$, $T_a=25^\circ C$)

Model No.	Symbol	MIN.	TYP.	MAX.	Unit
PQ1U181M2ZPH	V_o	1.740	1.8	1.860	V
PQ1U251M2ZPH		2.440	2.5	2.560	
PQ1U281M2ZPH		2.740	2.8	2.860	
PQ1U301M2ZPH		2.940	3.0	3.060	
PQ1U331M2ZPH		3.234	3.3	3.366	
PQ1U351M2ZPH		3.430	3.5	3.570	
PQ1U501M2ZPH		4.900	5.0	5.100	

Table.2 Output Noise Voltage

($V_{IN}=V_o(TYP)+1.0V$, $I_o=30mA$, $V_c=1.8V$, $C_n=0.1\mu F$, $10Hz < f < 100kHz$, $T_a=25^\circ C$)

Model No.	Symbol	MIN.	TYP.	MAX.	Unit
PQ1U181M2ZPH	$V_{no}(rms)$	-	15	-	μV
PQ1U251M2ZPH		-	25	-	
PQ1U281M2ZPH		-	25	-	
PQ1U301M2ZPH		-	30	-	
PQ1U331M2ZPH		-	30	-	
PQ1U351M2ZPH		-	35	-	
PQ1U501M2ZPH		-	50	-	

Fig.1 Test Circuit

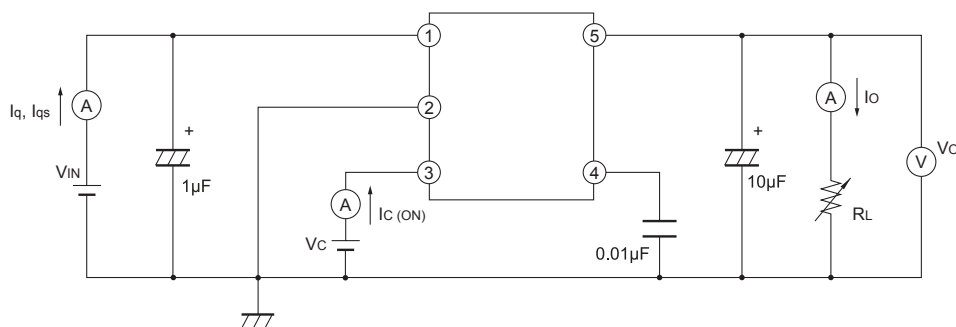

Fig.2 Test Circuit for Ripple Rejection

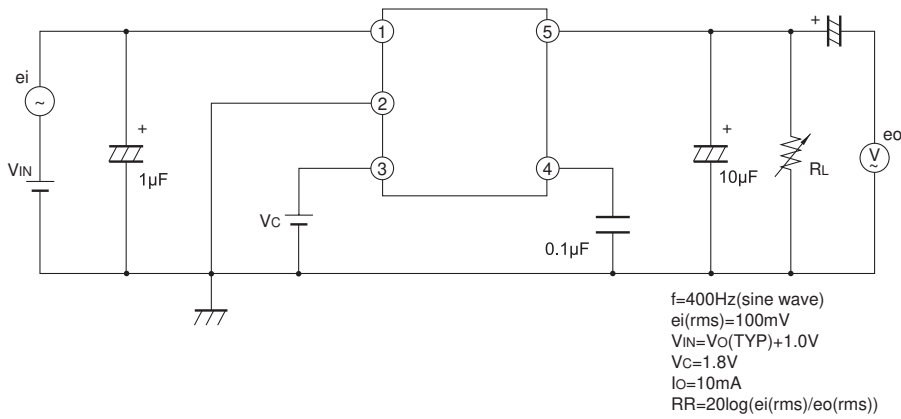
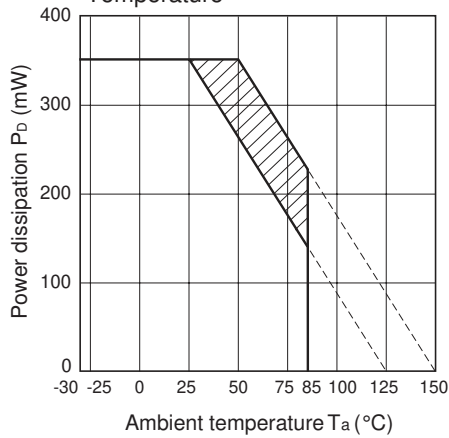

Fig.3 Power Dissipation vs. Ambient Temperature



Note) Oblique line portion: Overheat protection may operate in this area.

Fig.4 Overcurrent Protection Characteristics (Typical Value)

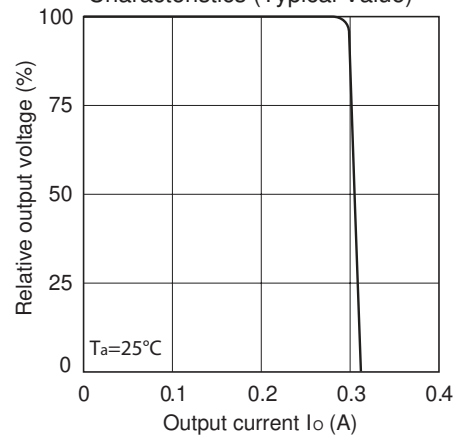

Fig.5 Output Voltage Fluctuation vs. Junction Temperature (PQ1U281M2ZPH)(Typical Value)

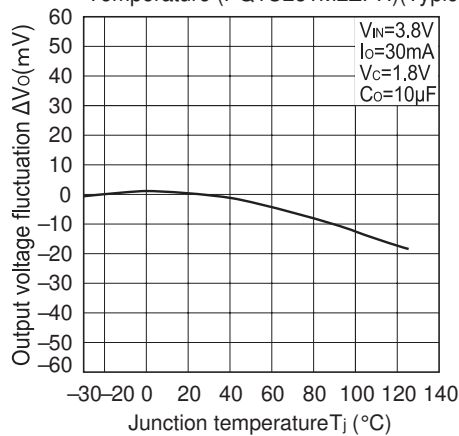

Fig.6 Output Voltage vs. Input Voltage (PQ1U281M2ZPH)(Typical Value)

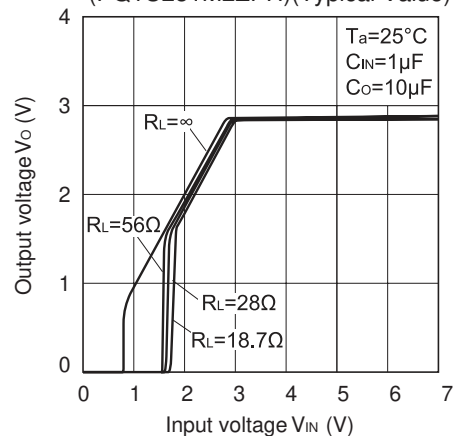

Fig.7 Circuit Operating Current vs. Input Voltage (PQ1U281M2ZPH)(Typical Value)

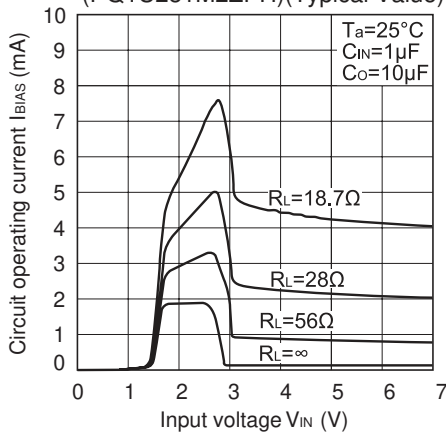

Fig.8 Dropout Voltage vs. Junction Temperature (PQ1U281M2ZPH)(Typical Value)

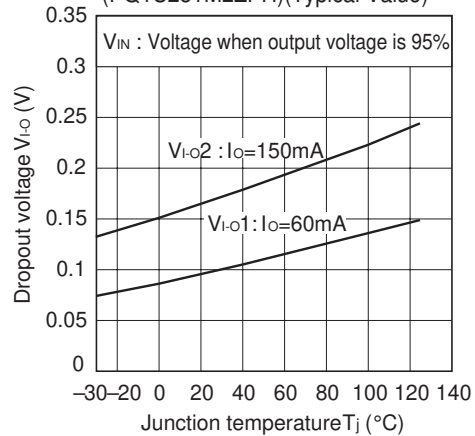

Fig.9 Quiescent Current vs. Junction Temperature (Typical Value)

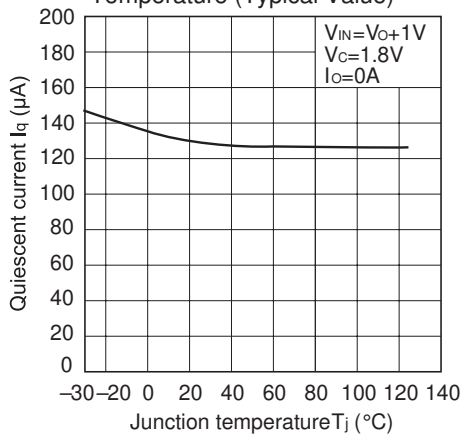

Fig.10 Ripple Rejection vs. Input Ripple Frequency (PQ1U281M2ZPH)(Typical Value)

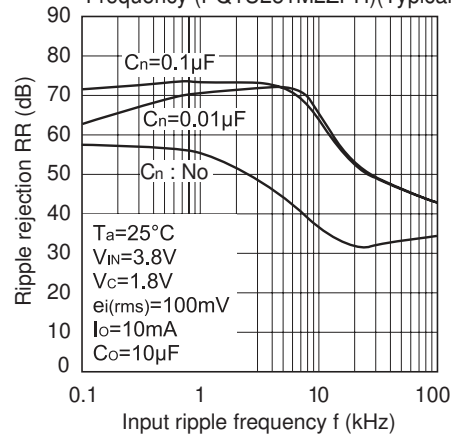

Fig.11 Dropout Voltage vs. Output Current (Typical Value)

