



Distar Technology Limited

[Http://www.distarltd.com](http://www.distarltd.com)

Tel:86-755-26645997

Fax:86-755-26645987

SPECIFICATIONS FOR LCD MODULE

DS-G160128STBWW

PIXELS: 160 X 128 DOTS

OUTLINE DIMENSION: 129.0 X 102.0 MM

VIEWING AREA: 101.0 X 82.0 MM

DOT SIZE: 0.54 X 0.54 MM

DOT PITCH: 0.58 X 0.58 MM

REVISION RECORD

REV.	DATE	PAGE	COMMENT
A	2007-3-15		NEW RELEASE

CONTENTS

1. LCD MODULE NUMBERING SYSTEM
 2. DISPLAY MODE MECHANICAL CHARACTERISTICS
 - 2.1 DISPLAY SPECIFICATIONS
 - 2.2 MECHANICAL DATA
 - 2.3 MECHANICAL DRAWINGS
 3. CIRCUIT BLOCK DIAGRAM
 - 3.1 Electrical Block Diagram
 - 3.2 Pins Definition
 - 3.3 Power Supply For LCM Driving
 4. ABSOLUTE MAXIMUM RATINGS
 - 4.1 Electrical Absolute Maximum Ratings
 - 4.2 Environmental Absolute Maximum Ratings
 5. ELECTRICAL CHARACTERISTICS
 - 5.1 DC Characteristics
 - 5.2 AC Characteristics
 6. BACKLIGHT CHARACTERISTICS
 - 6.1 Absolute Maximum Ratings
 - 6.2 Operating Parameters
 7. ELECTRO-OPTICAL CHARACTERISTIC
 8. DISPLAY CONTROL INSTRUCTION
 - 8.1 INSTRUCTION TABLE
 - 8.2 Character Table
 - 8.3 SOFTWARE EXAMPLES
 9. INSPECTION STANDARDS
 10. PRECAUTIONS IN USING LCM
-

1. LCD MODULE NUMBERING SYSTEM

FOR DS-G160128STBWW

DS DISTAR TECHNOLOGY LIMITED
G DISPLAY CONTENTS G---GRAPHIC TYPE

160128 160X128 PIXELS LCD PANEL

ST LCD TYPE:STN

B BACKGROUND COLOUR : BULE

W BACKLIGHT COLOR : WHITE

W WIDE TEMPRETURE

2. DISPLAY MODE AND MECHANICAL CHARACTERISTICS

2.1 DISPLAY SPECIFICATIONS

- LCD MODE : STN-NEGATIVE-TRANSMISSIVE
- DISPLAY COLOR : WHITE
- BACKGROUND COLOUR : BLUE
- DRIVING DUTY : 1/128DUTY
- BIAS : 1/9 BIAS
- VIEWING DIRECTION : 6 O’CLOCK
- BACKLIGHT : SIDE LED BACKLIGHT
- BACKLIGHT COLOR : WHITE

2.2 MECHANICAL DATA

ITEM	STANDARD VALUE	UNIT
NUMBER OF PIXELS	160(COLUMNS) X128(ROWS)	
OUTLINE DIMENSIONS	129.0(W)X102.0(H) X 14.0(T)	mm
EFFECTTVE VIEWING AREA	101.0(W) X 82.0(H)	mm
DOT SIZE	0.54(W) X 0.54(H)	mm
DOT PITCH	0.58(W) X 0.58(H)	mm
APPROX WEIGHT	260	g

2.3 MECHANICAL DRAWINGS

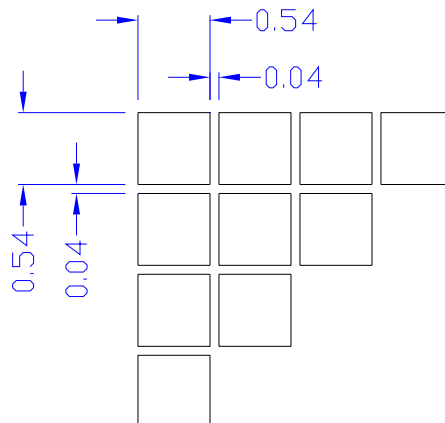

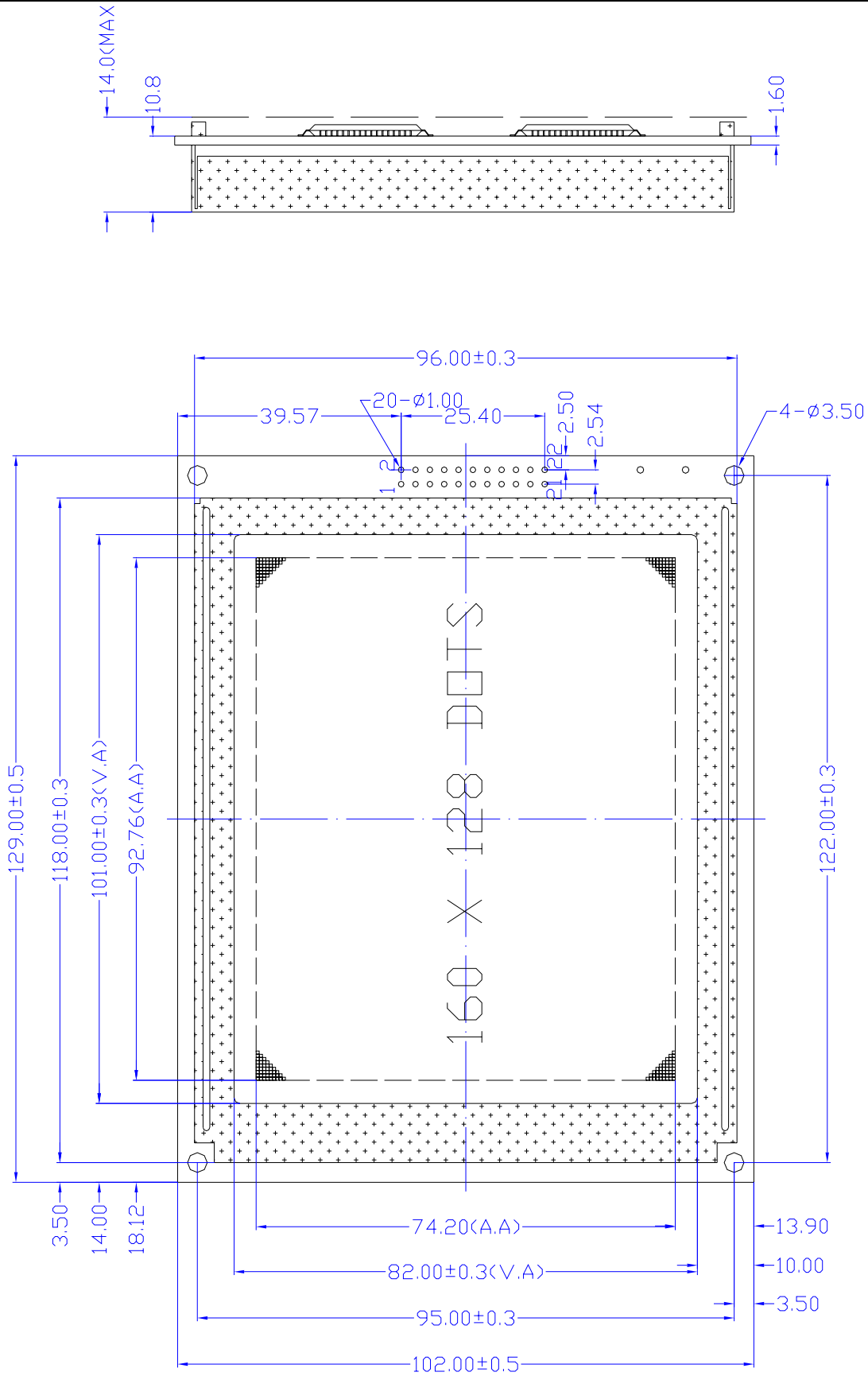

3. CIRCUIT BLOCK DIAGRAM

3.1 Electrical Block Diagram

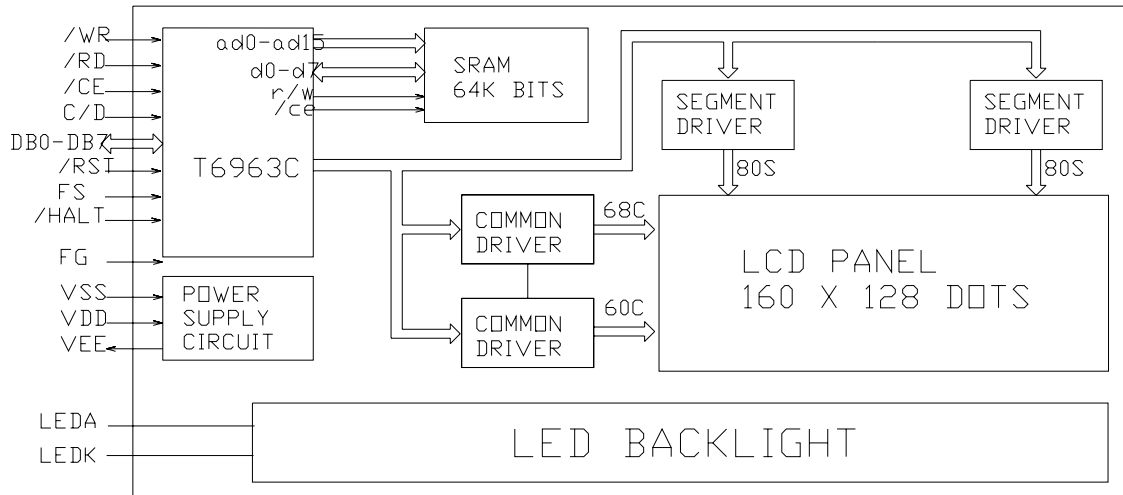

3.2 Pins Definition

PIN	SYMBOL	FUNCTION
1	FG	FRAME GROUND
2	Vss	Power Supply(GND)
3	Vdd	Power Supply For Logic(+5V)
4	Vo	Power Supply For LCD Driving (Contrast Adjust)
5	VEE	NEGATIVE VOLTAGE INPUT/OUTPUT
6	/WR	DATA WRITE
7	/RD	DATA READ
8	/CE	CHIP ENABLE FOR T6963C
9	C/D	COMMAND/DATA SELECTION
10	/HALT	CLOCK OPERATING STOP SIGNAL
11	/RST	RESET T6963C(Low EFFECTIVE)
12--19	DB0—DB7	DATA BUS
20	NC	NO CONNECTION
21	LEDA	LED BACKLIGHT POWER SUPPLY(+)(+5V)

22	LEDK	LED BACKLIGHT POWER SUPPLY(-)(0V)
----	------	-----------------------------------

3.3 Power Supply For LCM Driving

3.3.1 For LCM With DC/DC on Board(Internal Negative Voltage)

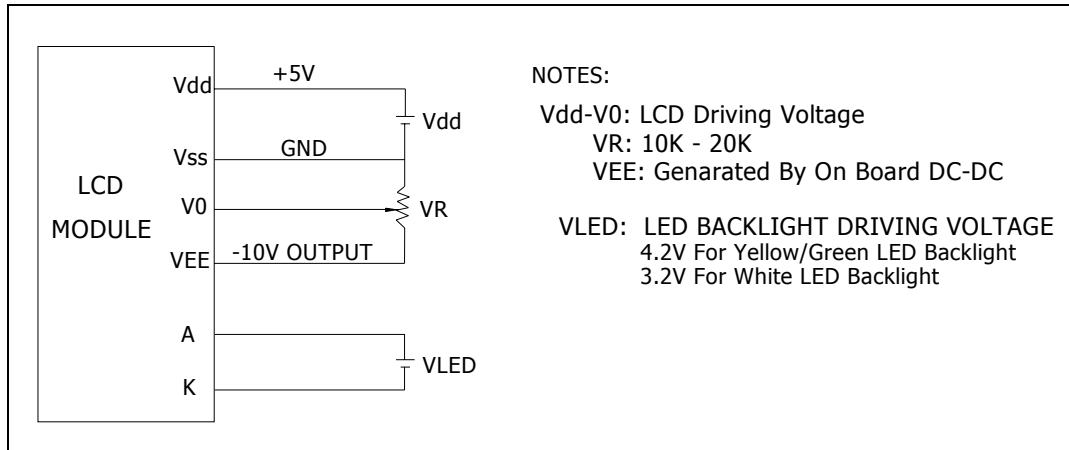

3.3.2 For LCM without DC/DC on Board(Negative Voltage input)

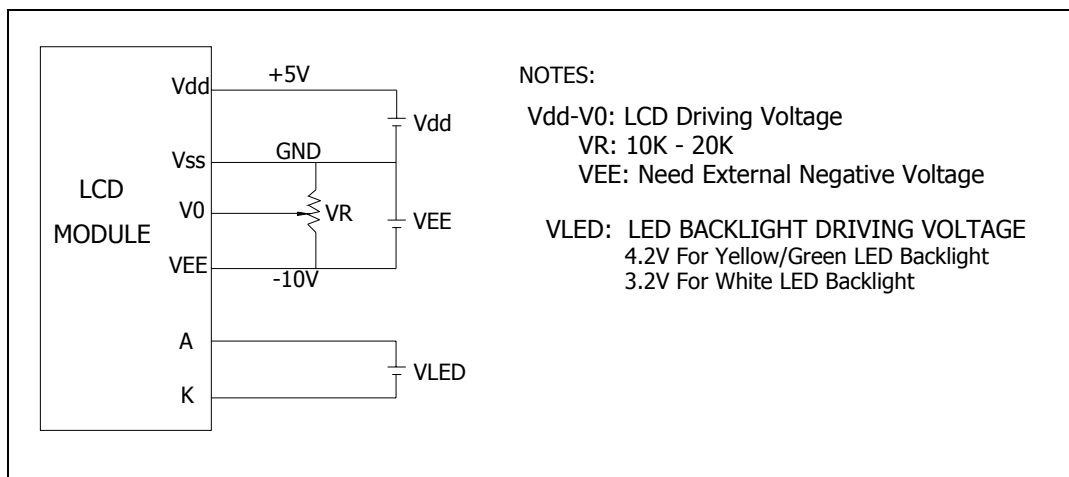

4. ABSOLUTE MAXIMUM RATINGS

4.1 Electrical Absolute Maximum Ratings

ITEM	SYMBOL	CONDITION	MIN	MAX	UNIT
Supply Voltage (Logic)	Vdd – Vss	-	-0.3	7.0	V
Supply Voltage (LCD Drive)	Vdd – V0	-	0	25.0	V

Input Voltage	Vi	-	-0.3	Vdd +0.3	V
---------------	----	---	------	----------	---

4.2 Enviromental Absolute Maximum Ratings

ITEM	SYMBOL	CONDITIONS	MIN	MAX	UNIT
Operating Temp	Topr	-Normal temp.	-20	70	deg C
Storage Temp	Ttsg	version-	-30	80	deg C
Humidity Endurance	RH	no ondensation Ta<=40 deg	-	95	%
Vibration	-	100-300Hz, X/Y/Z directions, 1 hour	-	4.9m/ss 0.5g	-
Shock	-	10 mS X/Y/Z direction 1 time each	-	29.4m/ss 3.0g	-

5. ELECTRICAL CHARACTERISTICS

5.1 DC Characteristics

Electrical Characteristics at Ta=25 deg C, Vdd = 5V + / - 5%

ITEM	SYMBOL	CONDITION	MIN	TYP	MAX	UNIT
Supply Voltage (logic)	Vdd-Vss	-	4.5	5.0	5.5	V
Supply Voltage (LCD)	Vdd-V0	Vdd = 5V	-	18	-	V
Input signalVoltage (for CD, DB0-7,/WR,/R/CS)	V-ih	"H" level	2.2	-	Vdd	V
	V-il	"L" level	0	-	0.6	V
Supply Current (logic)	Icc	-	-	1	1.2	mA
Supply Current	Io	-	0.15	0.22	0.27	mA

(LCD)						
-------	--	--	--	--	--	--

5.2 AC Characteristics

(1) SWITCHING CHARACTERISTICS (1)

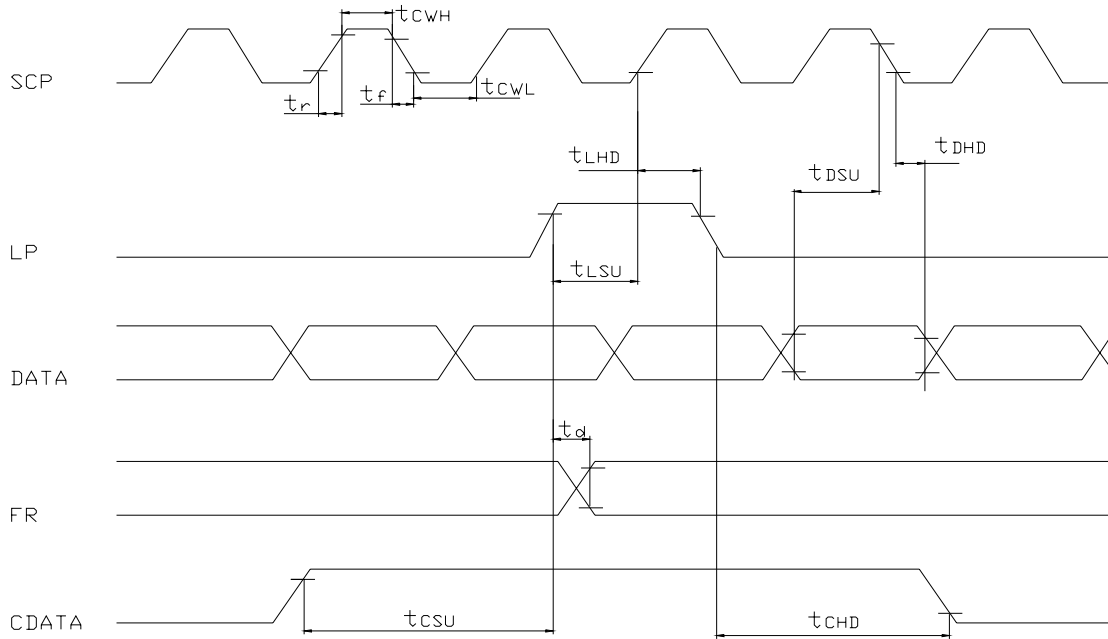

TIMING SPECIFICATIONS at $T_a = 25 \text{ deg C}$, $V_{dd} = 5V \pm 10\%$, $V_{ss} = 0V$

ITEM	SYMBOL	MIN	MAX	UNIT
OPERATING FREQUENCY	f_{SCP}	-	2.75	MHZ
SCP PULSE WIDTH	T_{CWH}, T_{CWL}	150	-	ns
SCP RISE/FALL TIME	t_r, t_f	-	30	ns
LP SET-UP TIME	t_{lsu}	150	290	ns
LP HOLD TIME	t_{lhd}	5	40	ns
DATA SET-UP TIME	t_{dsu}	170	-	ns
DATA HOLD TIME	t_{dhd}	80	-	ns
FR DELAY TIME	T_d	0	90	ns
CDATA SET-UP TIME	T_{CSU}	450	850	ns
CDATA HOLD TIME	T	450	950	ns

(2) BUS TIMING

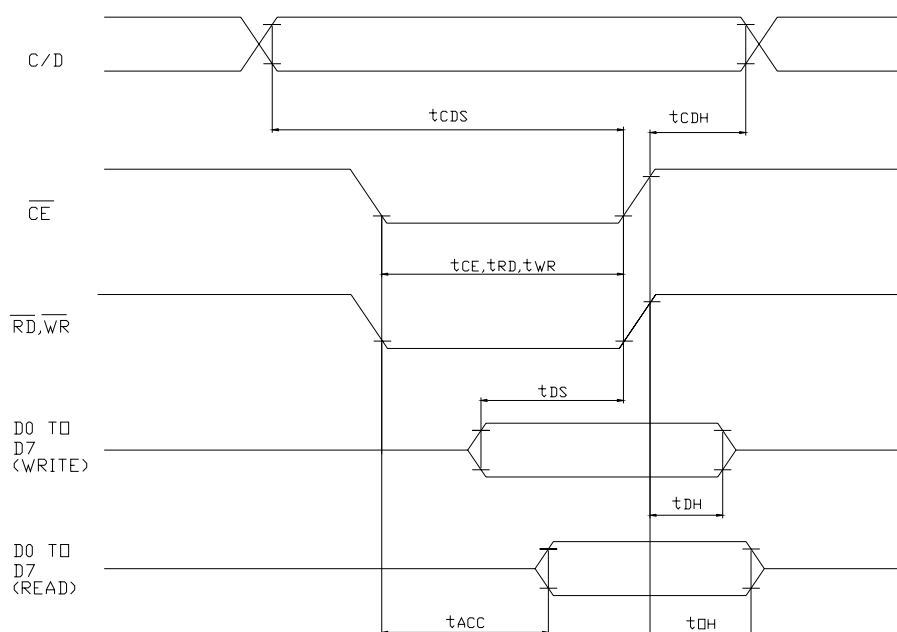

ITEM	SYMBOL	MIN	MAX	UNIT
C/D SET-UP TIME	T_{CDS}	100	-	ns
C/D HOLD TIME	T_{CDH}	10	-	ns
/CE, /RD, /WR PULSE WIDTH	T_{CE} , T_{RD} , T_{WR}	80	-	ns
DATA SET-UP TIME	T_{DS}	80	-	ns
DATA HOLD TIME	T_{DH}	40	-	ns
ACCESS TIME	T_{ACC}	-	150	ns
OUTPUT HOLD TIME	T_{OH}	10	50	ns

(3) EXTERNAL RAM TIMING

EXTERNAL RAM READ TIMING

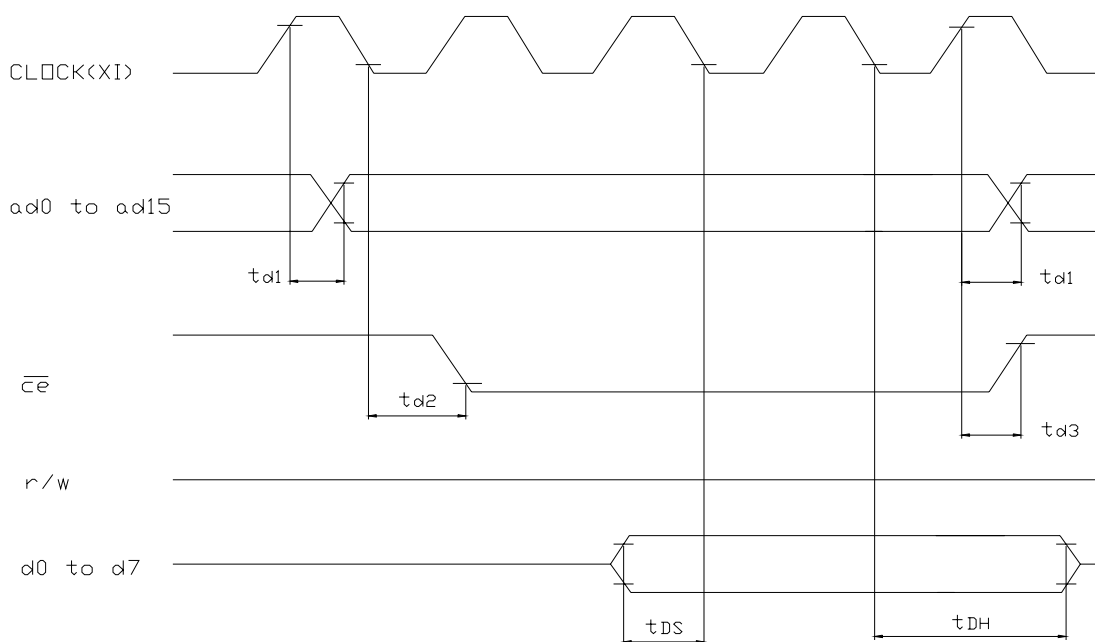

EXTERNAL RAM WRITE TIMING

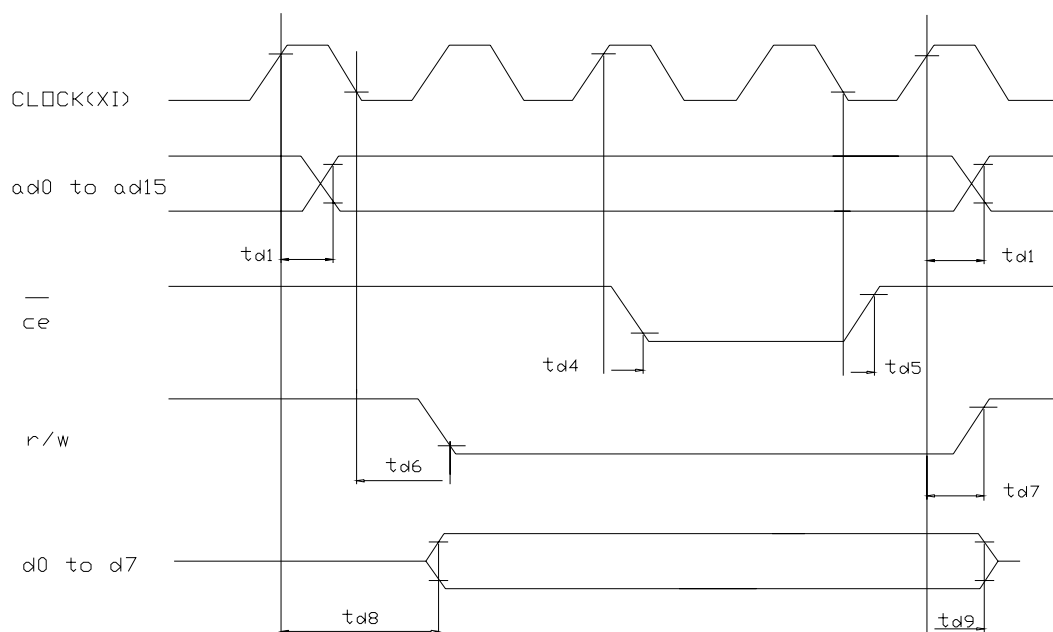

ITEM	SYMBOL	MINI	MAX	UNIT
ADDRESS DELAY TIME	t_{d1}	-	250	ns
/CE FALL DELAY TIME	t_{d2}	-	180	ns
/CE RISE DELAY TIME	t_{d3}	-	180	ns
DATA SET-UP TIME	t_{DS}	0	-	ns
DATA HOLD TIME	t_{DH}	30	-	ns
/CE FALL DELAY TIME	t_{d4}	-	200	ns
/CE RISE DELAY TIME	t_{d5}	-	200	ns
R/W FALL DELAY TIME	t_{d6}	-	180	ns
R/W RISE DELAY TIME	t_{d7}	-	180	ns
DATA STABLE TIME	t_{d8}	-	450	ns
DATA HOLD TIME	t_{d9}	-	200	ns

6. BACKLIGHT CHARACTERISTICS

6.1 Absolute Maximum Ratings

ITEM	SYMBOL	CONDITION	MIN	MAX	UNIT
Forward Current	I_{fm}	-	-	200	mA
Reverse Voltage	V_r	-	-	5.3	V
Power Dissipation	P_d	-	-	1000	mW

6.2 Operating Parameters

ITEM	SYMBOL	CONDITION	MIN	TYP.	MAX	UNIT
Forward Voltage	V_f^*	$I_f=90mA-$	-	5.0	5.3	V
Peak Wavelength	λ	$I_f=90mA-$	-	-	-	nm

* V_f is the voltage applied to Pin15 and Pin16.

7. ELECTRO-OPTICAL CHARACTERISTICS

ITEM	SYMBOL	CONDITION	MIN.	TYP.	MAX.	UNIT	REF.
Contrast	CR	25°C	--	12	--		Note1
Rise Time	tr	25°C	--	160	240	ms	Note2
Fall Time	tf	25°C	--	100	150	ms	note 2
Viewing Angle	$\theta 1 - \theta 2$	25°C	--	--	60	DEG	Note 3
	$\varnothing 1, \varnothing 2$		-40	--	40		
Frame Frequency	Ff	25°C	--	70	--	Hz	note 2

Note(1): Contrast ratio is defined under the following condition:

CR= $\frac{\text{brightness of selected condition}}{\text{brightness of non-selected condition}}$

- (a). Temperature-----25C
- (b). Frame Frequency-----64Hz
- (c). Viewing angle----- $\theta = 0, \varnothing = 0$
- (d). Operating Voltage---5.0V

Note(2): definition of response time:

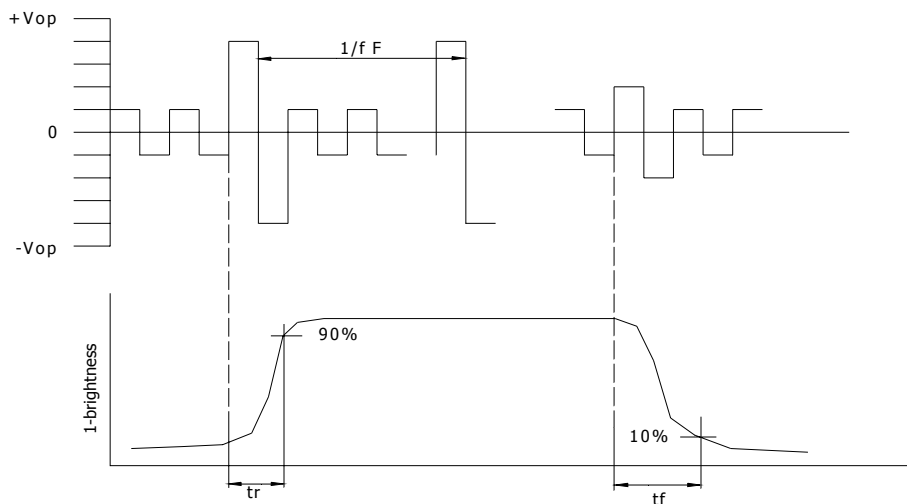

Condition:

- (a). Temperature-----25C
- (b). Frame Frequency-----64Hz
- (c). Viewing angle----- $\theta = 0, \varnothing = 0$
- (d). Operating Voltage---5.0V

Note(3): definition of view angle:

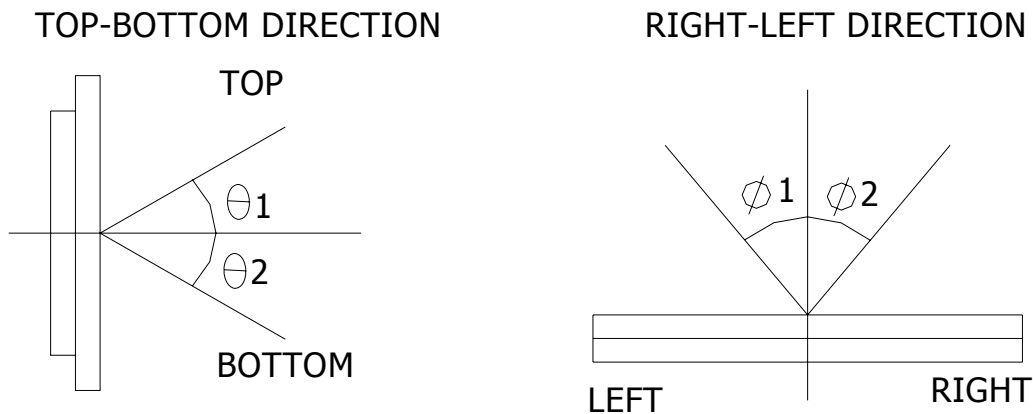

8. DISPLAY CONTROL INSTRUCTION

8.1 INSTRUCTION TABLE

COMMAND	CODE								PA RA	FUNCTION	EXECU TIME
	D 7	D6	D5	D4	D3	D2	D1	D0			
REGISTER S SETTING	0	0	1	0	0	N2	N1	N0	2	N2 N1 N0 0 0 1 SET CURSOR POINTER 0 1 0 SET OFFSET REGISTER 1 0 0 SET ADDRESS POINTER	STATUS CHECK
SET CONTROL WORD	0	1	0	0	0	0	N1	N0	2	N1 N0 0 0 SET TEXT HOME ADDRESS 0 1 SET TEXT AREA 1 0 SET GRAPHIC AREA 1 1 图形区域设置	STATUS CHECK
MODE SET	1	0	0	0	C	N2	N1	N0	-	CG=0: CGROM MODE	

					G					CG=1: CGTAM MODE N2 N1 N0 GRAPHIC AND TEXT 0 0 0 "OR" 0 0 1 "EXOR" 0 1 1 "AND" 1 0 0 TEXT ATTRIBUTE MODE	
DISPLAY MODE	1	0	0	1	N3	N2	N1	N0	-	N3=0: GRAPHIC OFF N3=1: GRAPHIC ON N2=0: TEXT OFF N2=1: TEXTON N1=0: CURSOR OFF N1=1: CURSOR ON N0=0: BLINK OFF N0=1: BLINK ON	32× 1/fosc
CURSOR PATTERN SELECT	1	0	1	0	0	N2	N1	N0	-	N2, N1, N0 SET THE LINES OF CURSOR N2 N1 N0 0 0 0 1-LINE CURSOR . . . 1 1 1 8-LINE CURSOR	
DATA AUTO READ/WRITE	1	0	1	1	0	0	N1	N0	-	N1 N0 0 0 SET DATA AUTO WRITE 0 1 SET DATA AUTO READ 1 * AUTO RESET	
DATA READ/WRITE	1	1	0	0	0	N2	N1	N0	1	DATA WRITE AND READ BY 1 N2=0: INCREMENT /DECREMENT ADP =1: NONVARIABLE ADP N1=0: INCREMENT ADP 1 =1: DECREMENT ADP 1 N0=0: DATA WRITE =1:	

SCREEN PEEK	1	1	1	0	0	0	0	0	-	SCREEN PEEK	
SCREEN COPY	1	1	1	0	1	0	0	0	-	SCREEN COPY	
BIT SET/RESET	1	1	1	1	N3	N2	N1	N0	-	BIT RESET N3=0: BIT 0 =1: BIT 1	

8.2 Character Table

THE RELATION BETWEEN CHARACTER CODE AND CHARACTER PATTERN (CG ROM TYPE 0101)

MSB \ LSB	0	1	2	3	4	5	6	7	8	9	A	B	C	D	E	F
0		!	"	#	\$	%	&	'	()	*	+	,	-	.	/
1	0	1	2	3	4	5	6	7	8	9	:	;	<	=	>	?
2	a	H	B	C	D	E	F	G	H	I	J	K	L	M	N	O
3	P	Q	R	S	T	U	U	W	X	Y	Z	[\]	^	_
4	`	a	b	c	d	e	f	g	h	i	j	k	l	m	n	o
5	p	q	r	s	t	u	v	w	x	y	z	{		}	~	
6	ç	ö	é	ä	ä	ä	ä	ö	é	é	é	ï	ï	ï	ä	ä
7	é	æ	æ	ö	ö	ö	ü	ü	y	ö	ö	ø	ø	æ	æ	f

THE RELATION BETWEEN CHARACTER CODE AND CHARACTER PATTERN (CG ROM TYPE 0101)

MSB \ LSB	0	1	2	3	4	5	6	7	8	9	A	B	C	D	E	F
0		!	"	#	\$	%	&	'	()	*	+	,	-	.	/
1	0	1	2	3	4	5	6	7	8	9	:	;	<	=	>	?
2	@	A	B	C	D	E	F	G	H	I	J	K	L	M	N	O
3	P	Q	R	S	T	U	V	W	X	Y	Z	[\]	^	_
4	千	万	用	々	■	ヲ	フ	イ	ウ	エ	オ	カ	ユ	ヨ	ワ	
5	一	ア	イ	ウ	エ	オ	カ	キ	ク	ケ	コ	サ	シ	ス	セ	ソ
6	タ	チ	ツ	テ	ト	ナ	ニ	ヌ	ネ	ノ	ヒ	フ	ハ	ホ	マ	メ
7	ミ	ム	メ	モ	ト	一	ヨ	ラ	リ	ル	レ	ロ	ワ	ウ	エ	オ

8.3 SOFTWARE EXAMPLES

```

;*****
;
; CONTROLLER IC IS T6963C
;BUSYCHK,WRDAT,WRCOM,RDDAT,CLRSCR,ALLON
;THE MCU IS AT89C52

WR EQU P1.1
RD EQU P3.6
CE EQU P3.7
CD EQU P2.7
RST EQU P2.0
;HALT EQU VDD
;DB0--DB7 EQU P0.0--P0.7
    
```

DAT EQU 30H
DAT_R EQU 31H
CDAT1 EQU 32H
CDAT2 EQU 33H
COM EQU 34H
CLR1 EQU 35H
CLR2 EQU 36H
DL1 EQU 37H
DL2 EQU 38H
DL3 EQU 39H

;-----

ORG 30H

CLR RST

LCALL DELAY

SETB RST

LCALL DELAY

;INITIAL

MOV CDAT1,#00H ;SET SAD(FIRST ADDRESS) OF THE TEXT AREA:0000H

MOV CDAT2,#00H

MOV COM,#40H

LCALL WRCOM

MOV CDAT1,#14H ;SET TEXT AREA WIDTH: 14H

MOV CDAT2,#00H

MOV COM, #41H

LCALL WRCOM

MOV CDAT1,#00H ;SET SAD(FIRST ADDRESS) OF GRAPHIC AREA:0800H

MOV CDAT2,#08H

MOV COM,#42H

LCALL WRCOM

MOV CDAT1,#14H ;SET GRAPHIC AREA WIDTH: 14H

MOV CDAT2,#00H

MOV COM,#43H

```
LCALL WRCOM
MOV COM,#80H      ;MODE SET: OR, INTERAL CGROM
LCALL WRCOM
MOV COM,#0A0H    ;SET SHAPE OF THE CURSOR
LCALL WRCOM
MOV COM,#9CH     ;TEXT,GRAPHIC,CURSOR ON
LCALL WRCOM
                ;END OF INITIAL
```

```
LCALL CLRSCR
LCALL DELAY
```

```
                ;DRAWING THE BORDER(3LINES EACH SIDE)
```

```
MOV CDAT1,#00H   ;SET D-RAM ADDRESS
MOV CDAT2,#08H
MOV COM,#24H
LCALL WRCOM
MOV COM,#0B0H   ;SET AUTO-WRITE MODE
LCALL WRCOM
```

```
MOV R1,#03H     ;R1: ROW
LPR1_6: MOV R2,#14H ;R2: COLUMN
MOV DAT,#0FFH
LPR2_6: LCALL BUSYCHK3
LCALL WRDAT
DJNZ R2,LPR2_6
DJNZ R1,LPR1_6
```

```
MOV R1,#122D   ;R1: ROW
LPR1_7: MOV DAT,#0E0H
LCALL BUSYCHK3
LCALL WRDAT
MOV R2,#12H    ;R2: COLUMN
```

```
MOV DAT,#00H
LPR2_7: LCALL BUSYCHK3
        LCALL WRDAT
        DJNZ R2,LPR2_7
        MOV DAT,#07H
        LCALL BUSYCHK3
        LCALL WRDAT
        DJNZ R1,LPR1_7

        MOV R1,#03H      ;R1: ROW
LPR1_8: MOV R2,#14H     ;R2: COLUMN
        MOV DAT,#0FFH
LPR2_8: LCALL BUSYCHK3
        LCALL WRDAT
        DJNZ R2,LPR2_8
        DJNZ R1,LPR1_8

        MOV COM,#0B2H   ;TURN OFF AUTO-WRITE MODE
        LCALL WRCOM

        LCALL DELAY
        LCALL DELAY
        LCALL DELAY
        LCALL DELAY
        LCALL DELAY

                                ;DISPLAY DISP1
        LCALL CLRSCR
        MOV DPTR,#DISP1
        MOV R0,#04H
LPR0_1: CLR A
        MOVC A,@A+DPTR
        MOV R6,A
```

INC DPTR

CLR A

MOVC A,@A+DPTR

MOV R7,A

MOV CDAT1,#00H ;SET D-RAM ADDRESS

MOV CDAT2,#08H

MOV COM,#24H

LCALL WRCOM

MOV COM,#0B0H ;SET AUTO-WRITE MODE

LCALL WRCOM

MOV R1,#40H ;R1: ROW

LPR1_1: MOV R2,#14H ;R2: COLUMN

MOV DAT,R6

LPR2_1: LCALL BUSYCHK3

LCALL WRDAT

DJNZ R2,LPR2_1

MOV R2,#14H

MOV DAT,R7

LPR2_2: LCALL BUSYCHK3

LCALL WRDAT

DJNZ R2,LPR2_2

DJNZ R1,LPR1_1

MOV COM,#0B2H ;TURN OFF AUTO-WRITE MODE

LCALL WRCOM

LCALL DELAY

LCALL DELAY

LCALL DELAY

INC DPTR

DJNZ R0,LPR0_1

LCALL DELAY

LCALL CLRSCR

MOV CDAT1,#00H ;SET D-RAM ADDRESS

MOV CDAT2,#00H

MOV COM,#24H

LCALL WRCOM

MOV COM,#0B0H ;SET AUTO-WRITE MODE

LCALL WRCOM

;DISPLAY *

;WRITE CHARACTER--CGROM

MOV R1,#14H ;R1: ROW

LPR1_B: MOV R2,#1EH ;R2: COLUMN

MOV DAT,#0AH

LPR2_B: NOP

LCALL BUSYCHK3

LCALL WRDAT

DJNZ R2,LPR2_B

DJNZ R1,LPR1_B

MOV COM,#0B2H

LCALL WRCOM

LCALL DELAY

LCALL DELAY

LCALL DELAY

LCALL CLRSCR

MOV CDAT1,#00H ;SET D-RAM ADDRESS

MOV CDAT2,#00H

MOV COM,#24H

LCALL WRCOM

```
MOV COM,#0B0H    ;SET AUTO-WRITE MODE
LCALL WRCOM
                ;WRITE CHARACTER--CGROM
MOV R1,#20H     ;R1: ROW
LPR1_2: MOV R2,#1EH     ;R2: COLUMN
MOV R7,#21H
LPR2_3: MOV DAT,R7
LCALL BUSYCHK3
LCALL WRDAT
INC R7
CJNE R7,#3BH,NEXT1
MOV R7,#41H
NEXT1:  DJNZ R2,LPR2_3

MOV R2,#20H
MOV R7,#41H
LPR2_4: MOV DAT,R7
LCALL BUSYCHK3
LCALL WRDAT
INC R7
CJNE R7,#5BH,NEXT2
MOV R7,#21H
NEXT2:  DJNZ R2,LPR2_4
        DJNZ R1,LPR1_2

MOV COM,#0B2H
LCALL WRCOM
LCALL DELAY
LCALL DELAY
LCALL DELAY
LCALL DELAY
LCALL DELAY
SJMP $
```

.*****
,

;------BUSY CHECK(NON-AUTO MODE)-----

BUSYCHK: SETB CD ;CHECK ST0 AND ST1

CLR CE

SETB WR

CLR RD

MOV P0,#0FFH

NOP

JNB P0.0,\$

NOP

JNB P0.1,\$

NOP

SETB RD

RET

;------BUSY CHECK(AUTO READ)-----

BUSYCHK2: SETB CD ;CHECK ST2

CLR CE

SETB WR

CLR RD

MOV P0,#0FFH

NOP

JNB P0.2,\$

SETB RD

RET

;------BUSY CHECK(AUTO WRITE)-----

BUSYCHK3: SETB CD ;CHECK ST3

CLR CE

SETB WR

CLR RD

MOV P0,#0FFH

NOP

JNB P0.3,\$

SETB RD

RET

;------WRITE DATA-----

WRDAT: CLR CD ;WRITE DAT TO DATA STACK

CLR CE

SETB RD

MOV P0,DAT

CLR WR

NOP

SETB WR

RET

;------READ DATA-----

RDDAT: CLR CD ;READ DATA FROM DATA STACK

CLR CE

MOV P0,#0FFH

SETB WR

CLR RD

MOV DAT_R,P0

SETB RD

RET

;------WRITE COMMAND-----

WRCOM: ACALL BUSYCHK ;WRITE COMMAND: COM--COMMAND

MOV DAT,CDAT1 ;CDAT1--PARAMETER 1

ACALL WRDAT ;CDAT2--PARAMETER 2

ACALL BUSYCHK

MOV DAT,CDAT2

ACALL WRDAT

ACALL BUSYCHK

SETB CD

CLR CE

SETB RD

MOV P0,COM

CLR WR

NOP

SETB WR

RET

;-----CLEAR SCREEN-----

CLRSCR: MOV CDAT1,#00H ;SET D-RAM ADDRESS

MOV CDAT2,#00H

MOV COM,#24H

LCALL WRCOM

MOV COM,#0B0H ;SET AUTO-WRITE MODE

LCALL WRCOM

MOV CLR1,#00H

MOV CLR2,#20H

MOV DAT,#00H

CLS: LCALL BUSYCHK3

LCALL WRDAT

DJNZ CLR1,CLS

DJNZ CLR2,CLS

MOV COM,#0B2H ;END AUTO-WRITE MODE

LCALL WRCOM

RET

;-----DELAY-----

DELAY: MOV DL1,#02H

MOV DL2,#08FH

MOV DL3,#0FFH

LPDL1: NOP

NOP

DJNZ DL3,LPDL1

DJNZ DL2,LPDL1

DJNZ DL1,LPDL1

RET

.*****
;

DISP1: DB 088H,088H,022H,022H

DB 0FFH,000H,088H,022H

END

9. INSPECTION STANDARDS

The LCD shall be inspected under 40W white fluorescent light.
 The distance between the eyes and the samples shall be more than 30cm.
 All directions for inspecting the sample should be within 45 degree against perpendicular line.

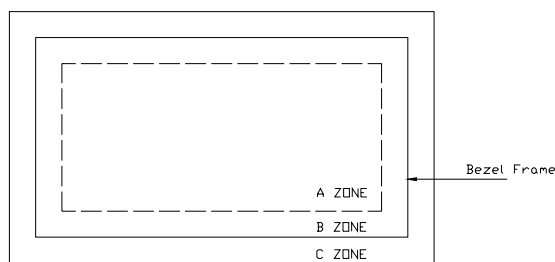
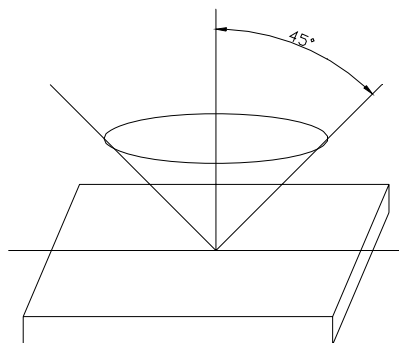

A Zone: Active Display Area
 B Zone: Area from Bezel Frame to A Zone
 C Zone: Rest Area of Bezel
 A Zone + B Zone=Effective Viewing Area

NO	PARAMETER	CRITERIA
1	Black and	

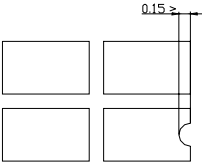
	<p>White Spots, Foreign Substances</p>	<table border="1"> <thead> <tr> <th colspan="2">Zone</th> <th colspan="3">Acceptable Number</th> </tr> <tr> <th colspan="2">DIMENSION(MM)</th> <th>A</th> <th>B</th> <th>C</th> </tr> </thead> <tbody> <tr> <td colspan="2">D≤0.1</td> <td></td> <td>*</td> <td>*</td> </tr> <tr> <td colspan="2">0.1<D≤0.2</td> <td>5</td> <td>5</td> <td>*</td> </tr> <tr> <td colspan="2">0.2<D≤0.3</td> <td>0</td> <td>1</td> <td>*</td> </tr> <tr> <td colspan="2">0.3<D</td> <td>0</td> <td>0</td> <td>*</td> </tr> </tbody> </table> <p>D=(long+short)/2 * Disregard</p> <table border="1"> <thead> <tr> <th colspan="2">Zone</th> <th colspan="3">Acceptable Number</th> </tr> <tr> <th>X(mm)</th> <th>Y(mm)</th> <th>A</th> <th>B</th> <th>C</th> </tr> </thead> <tbody> <tr> <td>-</td> <td>0.02≥W</td> <td></td> <td>*</td> <td>*</td> </tr> <tr> <td>2.0≥L</td> <td>0.03≥W</td> <td>3</td> <td>3</td> <td>*</td> </tr> <tr> <td>1.0≥L</td> <td>0.04≥W</td> <td>1</td> <td>2</td> <td>*</td> </tr> <tr> <td>1.0≥L</td> <td>0.05≥W</td> <td>0</td> <td>2</td> <td>*</td> </tr> <tr> <td>-</td> <td>0.05<W</td> <td></td> <td></td> <td></td> </tr> </tbody> </table> <p>X: Length Y: Width * Disregard</p>	Zone		Acceptable Number			DIMENSION(MM)		A	B	C	D≤0.1			*	*	0.1<D≤0.2		5	5	*	0.2<D≤0.3		0	1	*	0.3<D		0	0	*	Zone		Acceptable Number			X(mm)	Y(mm)	A	B	C	-	0.02≥W		*	*	2.0≥L	0.03≥W	3	3	*	1.0≥L	0.04≥W	1	2	*	1.0≥L	0.05≥W	0	2	*	-	0.05<W			
Zone		Acceptable Number																																																																	
DIMENSION(MM)		A	B	C																																																															
D≤0.1			*	*																																																															
0.1<D≤0.2		5	5	*																																																															
0.2<D≤0.3		0	1	*																																																															
0.3<D		0	0	*																																																															
Zone		Acceptable Number																																																																	
X(mm)	Y(mm)	A	B	C																																																															
-	0.02≥W		*	*																																																															
2.0≥L	0.03≥W	3	3	*																																																															
1.0≥L	0.04≥W	1	2	*																																																															
1.0≥L	0.05≥W	0	2	*																																																															
-	0.05<W																																																																		
<p>2</p>	<p>Air Bubbles (Between glass and polarizer)</p>	<table border="1"> <thead> <tr> <th colspan="2">Zone</th> <th colspan="3">Acceptable Number</th> </tr> <tr> <th colspan="2">Dimension(mm)</th> <th>A</th> <th>B</th> <th>C</th> </tr> </thead> <tbody> <tr> <td colspan="2">D≤0.1</td> <td></td> <td>*</td> <td>*</td> </tr> <tr> <td colspan="2">0.1<D≤0.2</td> <td>5</td> <td>5</td> <td>*</td> </tr> <tr> <td colspan="2">0.2<D≤0.3</td> <td>0</td> <td>1</td> <td>*</td> </tr> <tr> <td colspan="2">0.3<D</td> <td>0</td> <td>0</td> <td>*</td> </tr> </tbody> </table> <p>*: Disregard Total defects shall not exceed 3.</p>	Zone		Acceptable Number			Dimension(mm)		A	B	C	D≤0.1			*	*	0.1<D≤0.2		5	5	*	0.2<D≤0.3		0	1	*	0.3<D		0	0	*																																			
Zone		Acceptable Number																																																																	
Dimension(mm)		A	B	C																																																															
D≤0.1			*	*																																																															
0.1<D≤0.2		5	5	*																																																															
0.2<D≤0.3		0	1	*																																																															
0.3<D		0	0	*																																																															
<p>3</p>	<p>The Shape of Dot</p>	<p>(1) Dot Shape(with dent)</p>  <p>As per the sketch of left hand.</p> <p>(2) Dot Shape(with Projection)</p>																																																																	

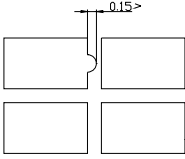
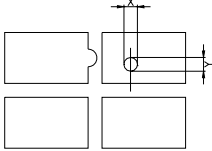
		 <p>Should not connect to next dot.</p> <p>(3) Pin Hole</p>  <p>$(X+Y)/2 < 0.2\text{mm}$ (less than 0.1mm is not counted)</p> <p>Total defects shall not exceed 5.</p>
4	Polarizer Scratches	
5	Polarizer Dirts	If the stains are removed easily from LCD surface, the module is not defective.
6	Color Variation	

10. PRECAUTIONS IN USING LCM

1. LIQUID CRYSTAL DISPLAY (LCD)

LCD is made up of glass, organic sealant, organic fluid, and polymer based polarizers. The following precautions should be taken when handing,

- (1). Keep the temperature within range of use and storage. Excessive temperature and humidity could cause polarization degradation, polarizer peel off or bubble.
- (2). Do not contact the exposed polarizers with anything harder than an HB pencil lead. To clean dust off the display surface. Wipe gently with cotton. Chamois or other soft material soaked in petroleum benzin.
- (3). Wipe off saliva or water drops immediately. Contact with water over a long period of time may cause polarizer deformation or color fading, while an active LCD with water condensation on its surface will cause corrosion of ITO electrodes.
- (4). Glass can be easily chipped or cracked from rough handing. especially at corners and edges.
- (5). Do not drive LCD with DC voltage.

2. Liquid Crystal Display Modules

2.1 Mechanical Considerations

LCM are assembled and adjusted with a high degree of precision. Avoid excessive shocks and do not make any alterations or modifications. The following should be noted.

- (1). Do not tamper in any way with the tabs on the tabs on the metal frame.
- (2). Do not modify the PCB by drilling extra holes, changing its outline, moving its components or modifying its pattem.

- (3). Do not touch the elastomer connector, especially insert an backlight panel (for example, EL).
- (4). When mounting a LCM make sure that the PCB is not under any stress such as bending or twisting. Elastomer contacts are very delicate and missing pixels could result from slight dislocation of any of the elements.
- (5). Avoid pressing on the metal bezel, otherwise the elastomer connector could be deformed and lose contact, resulting in missing pixels.

2.2. Static Electricity

LCM contains CMOS LSI's and the same precaution for such devices should apply, namely

- (1). The operator should be grounded whenever he/she comes into contact with the module. Never touch any of the conductive parts such as the LSI pads, the copper leads on the PCB and the interface terminals with any parts of the human body.
- (2). The modules should be kept in antistatic bags or other containers resistant to static for storage.
- (3). Only properly grounded soldering irons should be used.
- (4). If an electric screwdriver is used, it should be well grounded and shielded from commutator sparks.
- (5). The normal static prevention measures should be observed for work clothes and working benches; for the latter conductive (rubber) mat is recommended.
- (6). Since dry air is inductive to statics, a relative humidity of 50-60% is recommended.

2.3. Soldering

- (1). Solder only to the I/O terminals.
- (2). Use only soldering irons with proper grounding and no leakage.
- (3). Soldering temperature: $280\text{ }^{\circ}\text{C} \pm 10\text{ }^{\circ}\text{C}$
- (4). Soldering time: 3 to 4 sec.
- (5). Use eutectic solder with resin flux fill.
- (6). If flux is used, the LCD surface should be covered to avoid flux spatters. Flux residue should be removed afterwards.

2.4. Operation

- (1). The viewing angle can be adjusted by varying the LCD driving voltage V_0 .
- (2). Driving voltage should be kept within specified range; excess voltage shortens display life.
- (3). Response time increases with decrease in temperature.
- (4). Display may turn black or dark blue at temperatures above its operational range; this is (however not pressing on the viewing area) may cause the segments to appear "fractured".
- (5). Mechanical disturbance during operation (such as pressing on the viewing area) may cause the segments to appear "fractured".

2.5. Storage

If any fluid leaks out of a damaged glass cell, wash off any human part that comes into contact with soap and water. Never swallow the fluid. The toxicity is extremely low but caution should be exercised at all the time.

2.6. Limited Warranty

Unless otherwise agreed between DISTAR and customer, DISTAR will replace or repair any of its LCD and LC, which is found to be defective electrically and visually when inspected in accordance with DISTAR acceptance standards, for a period of one year from date of shipment. Confirmation of such date shall be based on freight documents. The warranty

DISTAR TECHNOLOGY LIMITED

DS-G160128STBWW

liability of DISTAR is limited to repair and/or replacement on the terms set forth above.
DISTAR will not responsible for any subsequent or consequential events.

END
