

ASMT-FJ10-AHJ00

Surface Mount AF Lamp

Description

The Broadcom[®] ASMT-FJ10-AHJ00 is a surface mount technology (SMT) dome lamp that uses an untinted, nondiffused lens to provide a high luminous intensity within a narrow radiation pattern. The device is made by encapsulating an LED chip on axial lead frame to form a molded epoxy lamp package with six bended leads for surfacing mounting.

This lamp type LED utilizes Aluminum Indium Gallium Phosphide (AlInGaP) material technology. The AlInGaP material has a very high luminous efficiency, capable of producing high light output over a wide range of drive currents. The color available for this SMT lamp package is 605-nm orange.

This narrow angle SMT lamp package is designed for applications that require long distance illumination and narrow beam pattern, such as an auxiliary flash for auto-focus function in a digital still camera. In order to facilitate pick-and-place operation, this SMT lamp is shipped in tape and reel, with 1000 units per reel. This package is compatible with Pb-free IR soldering process.

Eye Safety

This orange Surface Mount AF Lamp is used for a camera application. The LEDs have lenses, which focus the beam at about 10 mm from the front of the lens, from where the beam diverges relatively slowly. If the LEDs are placed in a product, they create a Class 1 LED to IEC/EN 60825-1 (2001) under all conditions of operation and single fault failure, as long as no collimating optics are added to the optical path.

Features

- Smooth, consistent narrow radiation pattern
- 8° view angle
- 4.8L × 4.8W × 5.33H mm package dimension
- Good intensity output
- Compatible with IR solder reflow
- Available in 16-mm tape on 15" (380mm) diameter reels
- Clear, non-diffused epoxy
- IEC/EN 60825-1 Eye Safety Class 1
- RoHS compliant

Applications

- Camera

CAUTION!

This LED is ESD sensitive. Please observe appropriate precautions during handling and processing. Refer to application note AN-1142 for additional details.

Figure 1: Package Dimensions

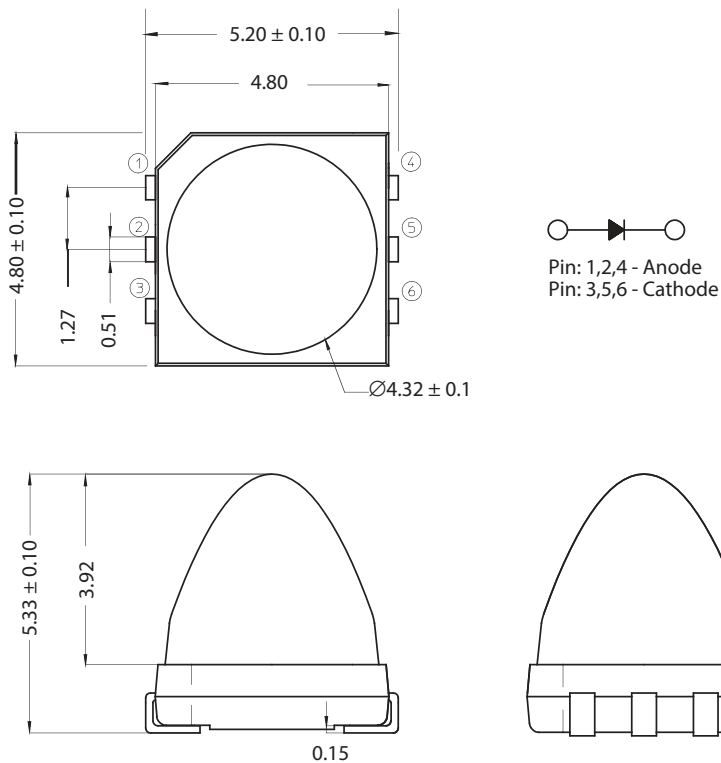
**NOTE:**

1. All Dimensions in millimeters.
2. Tolerance is ± 0.1 mm unless otherwise specified.

Device Selection Guide

Color	Part Number	Max. I_V (cd)	Max. I_V (cd)	Test Current (mA)	Dice Technology
Orange	ASMT-FJ10-AHJ00	25.5	56.0	20	AllnGaP

NOTE:

1. The luminous intensity, I_V , is measured at the mechanical axis of the lamp package. The actual peak of the spatial radiation pattern may not be aligned with this axis.
2. I_V tolerance = $\pm 15\%$.

Part Numbering System

A S M T - F x₁ x₃ x₄ - x₅ x₆ x₇ x₈ x₉

Code	Description	Option
x ₁	LED Chip Color	J Red Orange
		G Green
x ₃ x ₄	Package Type	10 4.8L × 4.8W × 5.33H mm package, Lead Frame
x ₅	LED Chip Technology	A AllnGaP
		N InGaN
x ₆	Minimum Intensity Bin Limits	Refer I _V Bin Category
x ₇	Maximum Intensity Bin Limits	Refer I _V Bin Category
x ₈	Color Bin	0 Full Distribution
x ₉	Packaging Option	0 Not Applicable

I_V Bin Category

Bin ID	Min. (cd)	Max. (cd)
H	25.5	33.0
I	33.0	43.0
J	43.0	56.0

I_V tolerance = ±15%.

Color Bin Category

Orange	Min. (nm)	Max. (nm)
1	600	604
2	604	608
3	608	612

Tolerance = ±1 nm.

Absolute Maximum Ratings at $T_A = 25^\circ\text{C}$

Parameter	ASMT-FJ10-AHJ00	Unit
DC Forward Current	50	mA
Power Dissipation	130	mW
LED Junction Temperature	110	$^\circ\text{C}$
Operating Temperature Range	-40 to +85	$^\circ\text{C}$
Storage Temperature Range	-40 to +100	$^\circ\text{C}$
Soldering Temperature	See Figure 7 .	

Optical Characteristics at $T_A = 25^\circ\text{C}$

Part Number	Color	Peak Wavelength λ_{PEAK} (nm)	Dominant Wavelength ^a λ_{D} (nm)	Viewing Angle $2\theta_{1/2}$ ^b (Degrees)	Luminous Efficacy, η_V ^c (lm/W)	Luminous Efficiency (lm/W)
		Typ.	Typ.	Typ.	Typ.	Typ.
ASMT-FJ10-AHJ00	Orange	612	605	8	355	27

a. The dominant wavelength, λ_{D} , is derived from the CIE Chromaticity Diagram and represents the color of the device.

b. $\theta_{1/2}$ is the off-axis angle where the luminous intensity is $1/2$ the peak intensity.

c. Radiant intensity, I_e in watts/steradian, can be calculated from the equation $I_e = I_V/\eta_V$, where I_V is the luminous intensity in candelas and η_V is the luminous efficacy in lumens/watt

Electrical Characteristics at $T_A = 25^\circ\text{C}$

Part Number	Forward Voltage, V_F (Volts) at $I_F = 20$ mA			Reverse Voltage, V_R at 10 mA	Capacitance, C (pF), $V_F = 0$ $f = 1$ MHz
	Min.	Typ.	Max.	Min.	Typ.
ASMT-FJ10-AHJ00	1.8	2.0	2.4	5	22

Note: V_F tolerance is $\pm 0.1\text{V}$.

Figure 2: Relative Intensity vs. Wavelength

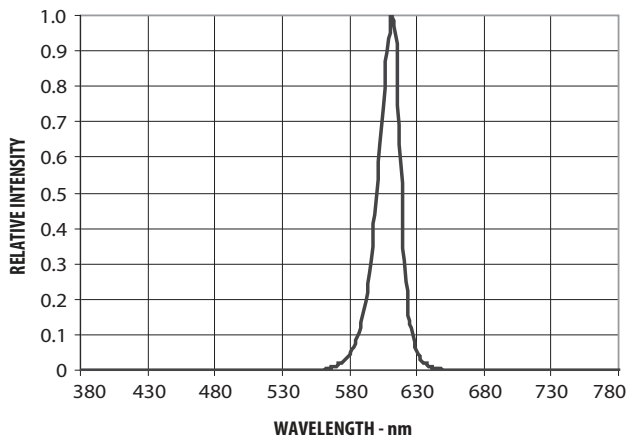

Figure 3: Forward Current vs Forward Voltage

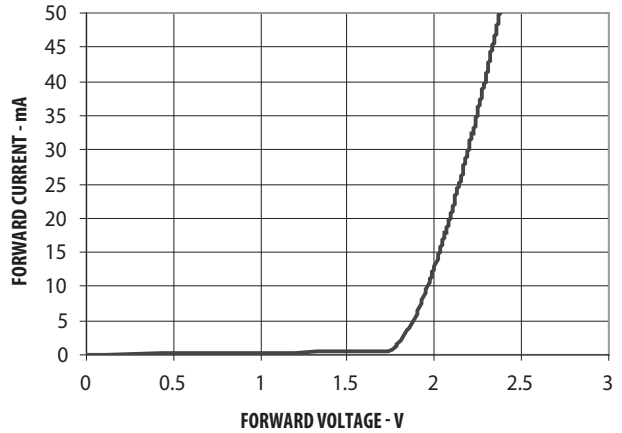

Figure 4: Relative Intensity vs. Forward Current

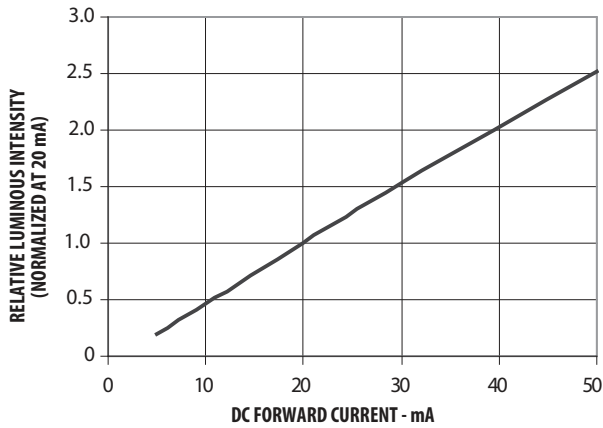

Figure 5: Radiation Pattern

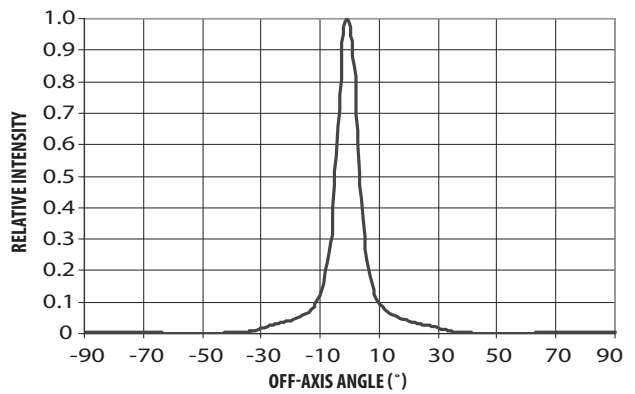

Figure 6: Maximum Forward Current vs Ambient Temperature

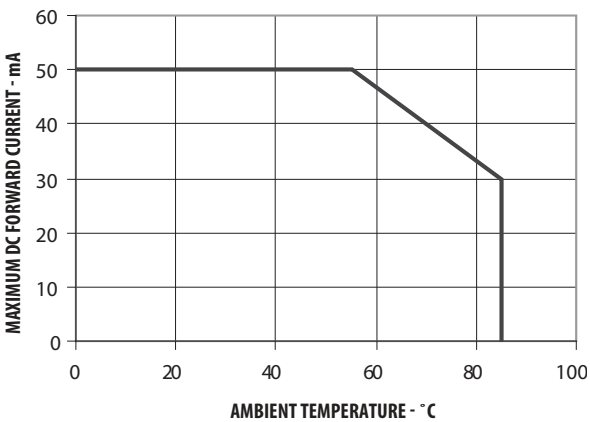

Figure 7: Recommended Reflow Soldering

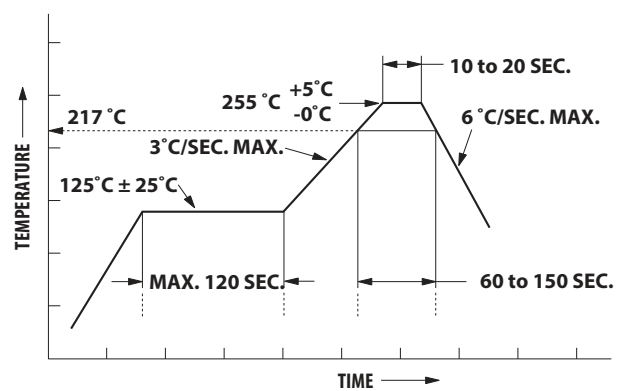

Figure 8: Recommended Soldering Land Pattern

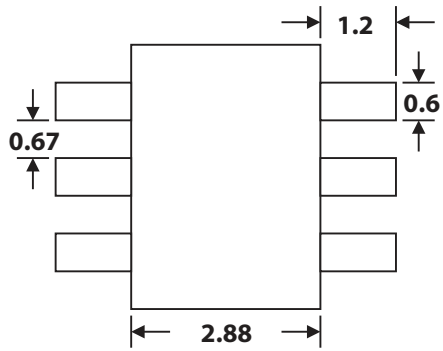

Figure 9: Reeling Orientations

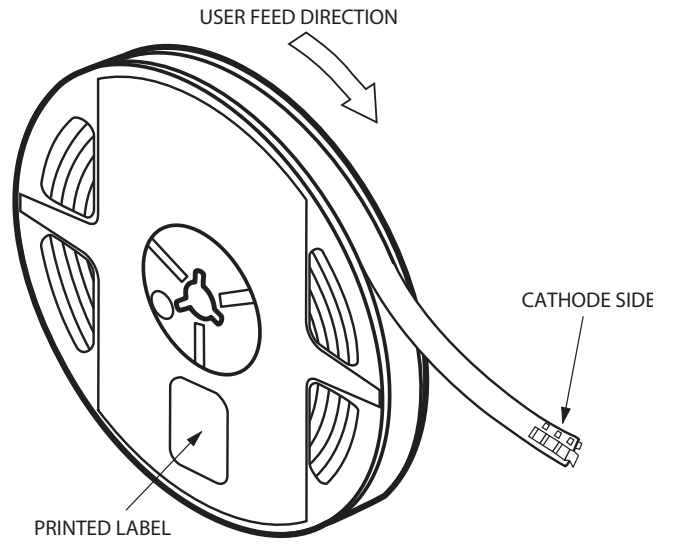

Figure 10: Reel Dimensions

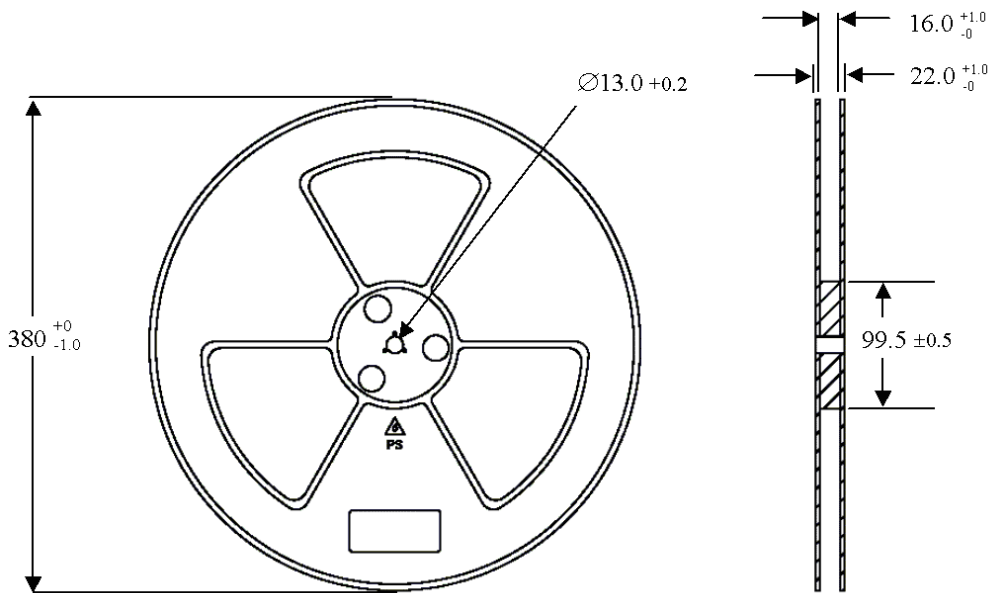

Figure 11: Tape Dimensions

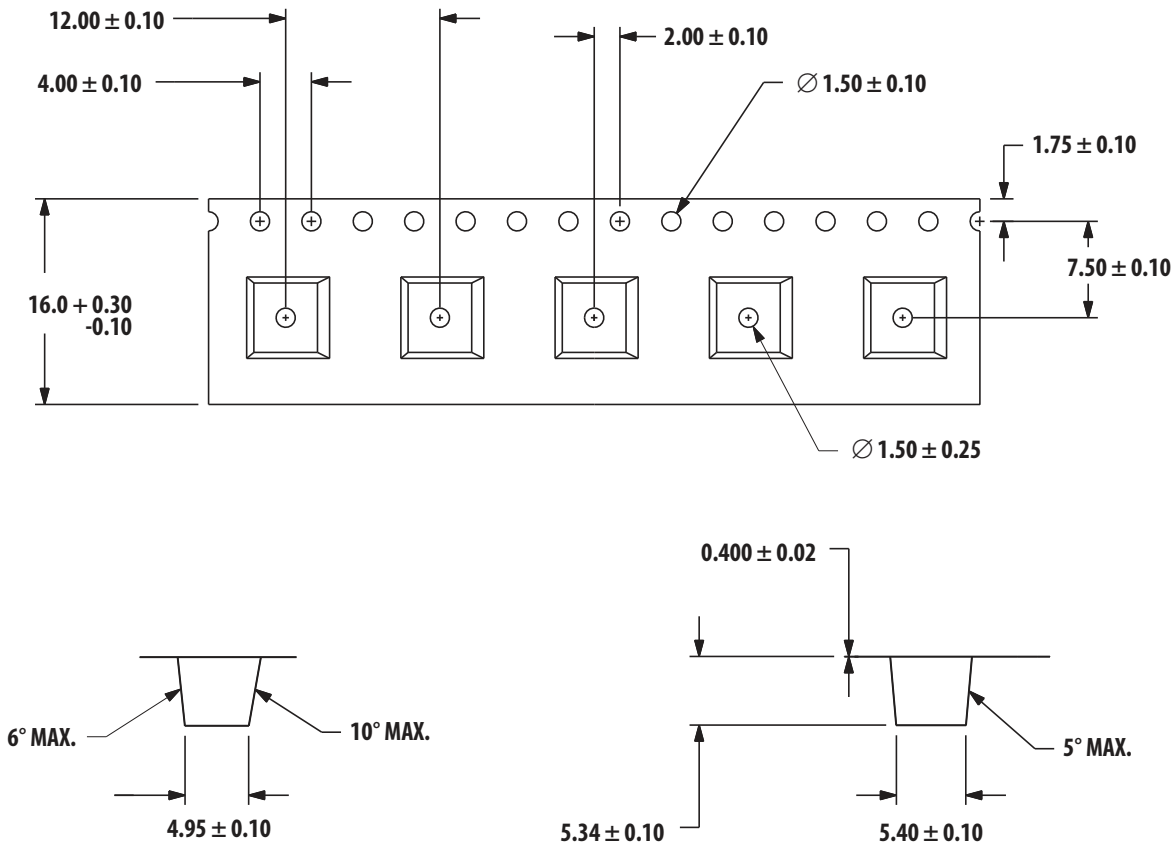
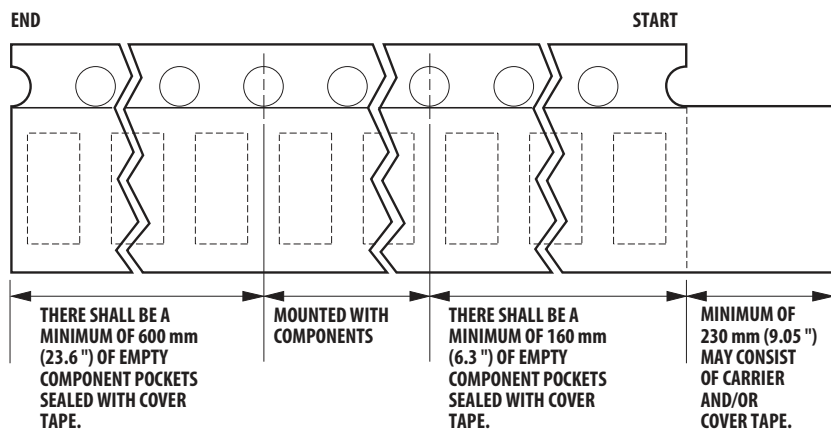

Figure 12: Tape Leader and Trailer Dimensions



Note: There will be a minimum of 600 mm (23.6") of empty component pockets sealed with cover tape.

NOTE:

1. All dimensions in millimeters.
2. Tolerance is ± 0.1 mm unless otherwise specified.

Broadcom, the pulse logo, Connecting everything, Avago Technologies, Avago, and the A logo are among the trademarks of Broadcom and/or its affiliates in the United States, certain other countries and/or the EU.

Copyright © 2017 by Broadcom. All Rights Reserved.

The term “Broadcom” refers to Broadcom Limited and/or its subsidiaries. For more information, please visit www.broadcom.com.

Broadcom reserves the right to make changes without further notice to any products or data herein to improve reliability, function, or design. Information furnished by Broadcom is believed to be accurate and reliable. However, Broadcom does not assume any liability arising out of the application or use of this information, nor the application or use of any product or circuit described herein, neither does it convey any license under its patent rights nor the rights of others.

