

CUSTOMER PRINT

PART NUMBER: SF8382-XPG-5XX

NOTES:

1. FINISHED ASSEMBLIES AND LOOSE PARTS BAGGED.
2. LABEL WITH CONXALL PART NUMBER, DATE CODE AND P/N BARCODE PLACED ON BAG
3. SEE DRAWING HPSFMI STD FOR HOLE PATTERNS
4. FOR FIELD INSTALLATION, SEE INSTRUCTION SHEET 2 OF 2.
5. ALL DIMENSIONS ARE REFERENCE EXCEPT THOSE WITH A TOLERANCE

ASSEMBLY P/ N	NO. OF CONTACT
SF8382-2PG-5XX	(2) # 16
SF8382-3PG-5XX	(3) # 16
SF8382-4PG-5XX	(4) # 16
SF8382-5PG-5XX	(5) # 16
SF8382-6PG-5XX	(6) # 16

520 = BACKSHELL WITH Ø.220 [5.6] GROMMET I.D.
 530 = BACKSHELL WITH Ø.330 [8.4] GROMMET I.D.

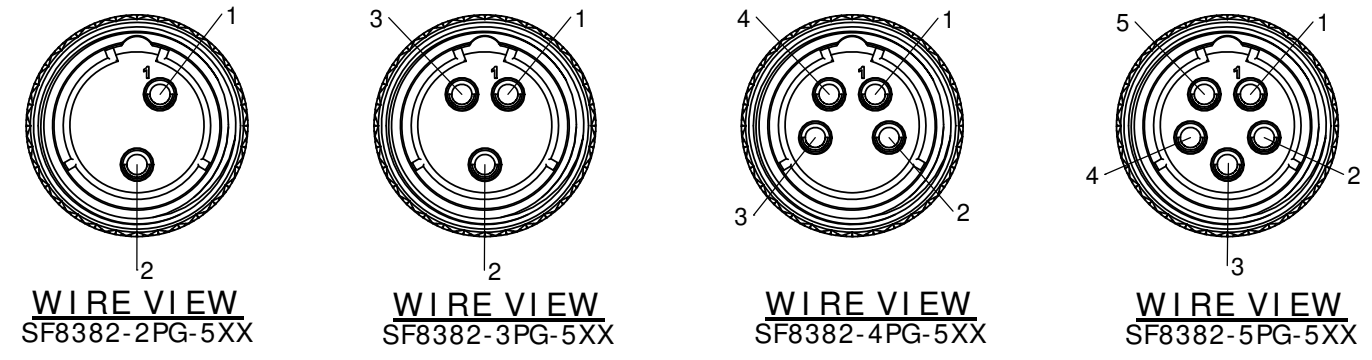
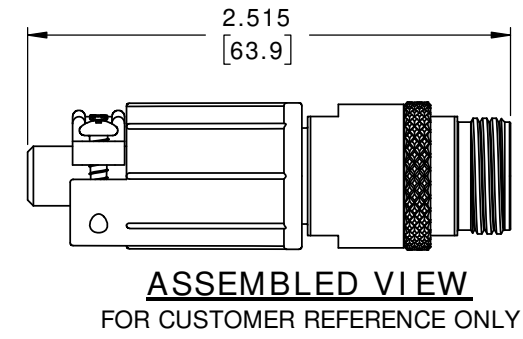
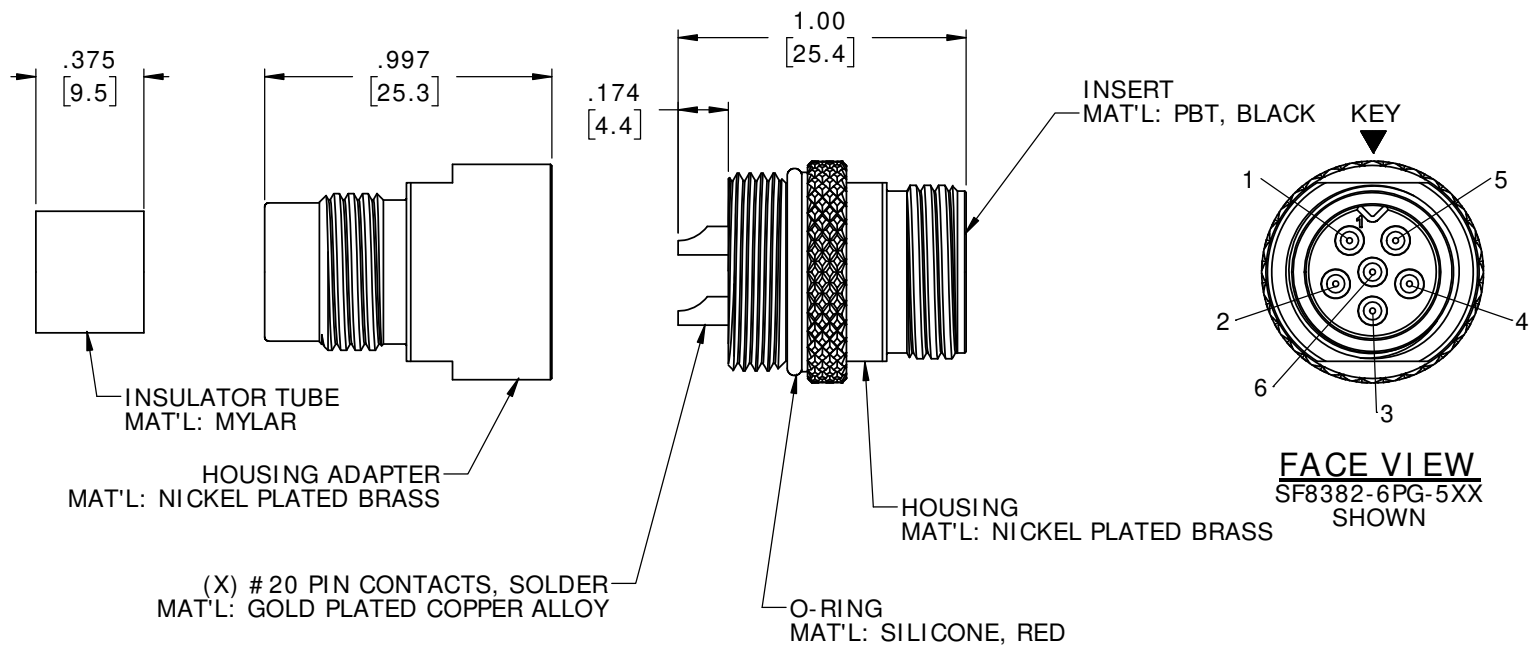
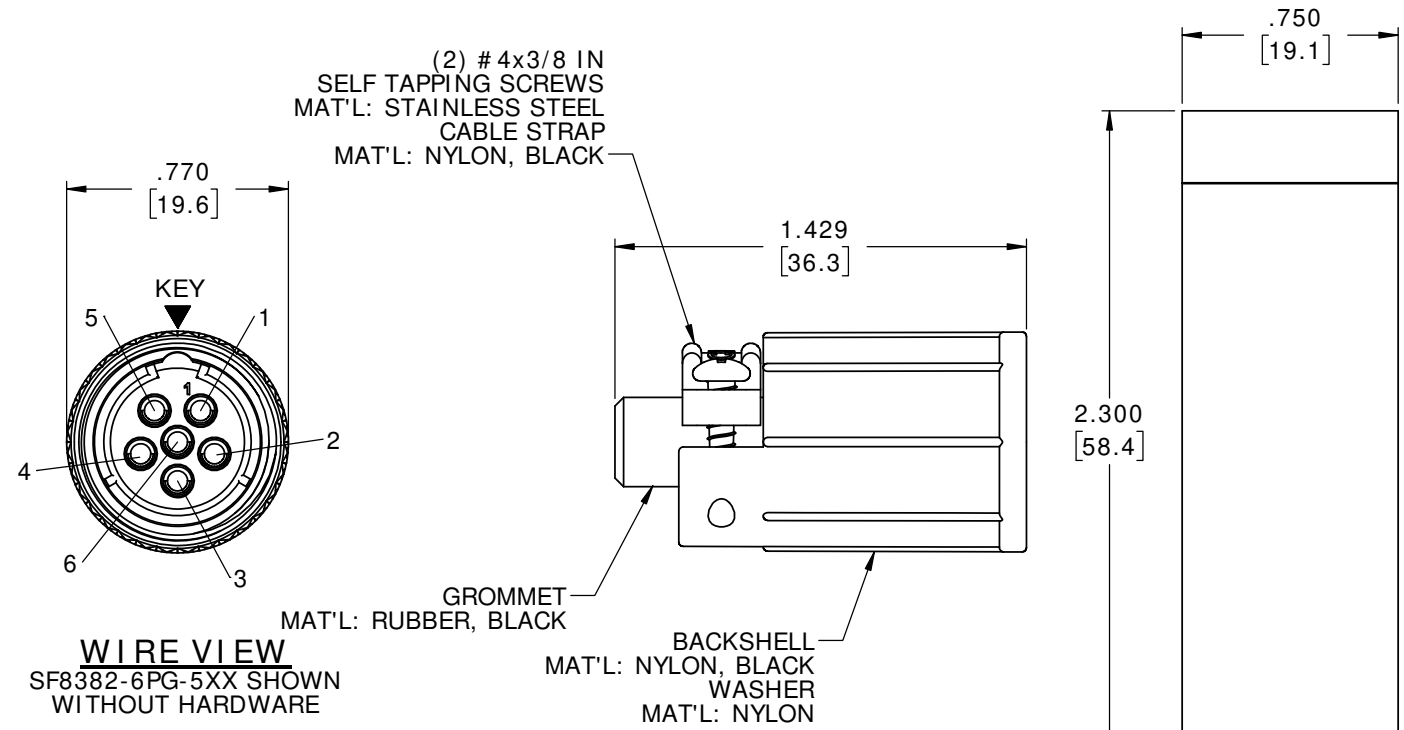

DIMENSIONS IN BRACKETS [] ARE IN MILLIMETERS

CUSTOMER APPROVAL

THIS DOCUMENT CONTAINS CONFIDENTIAL INFORMATION PROPRIETARY TO CONXALL CORPORATION. ANY REPRODUCTION, DISCLOSURE, OR USE OF THIS DOCUMENT / INFORMATION IS EXPRESSLY PROHIBITED UNLESS AUTHORIZED IN WRITING BY CONXALL CORPORATION.

APPROVED BY: _____

DATE: _____

REV.	INIT.	DATE	DESCRIPTION
A	MA	01-29-19	RELEASED PER PDR 17011
	PNK	12-20-18	O-RING 4290S REPLACES SF6290S-1.
	PNK	1-30-18	DRAWING CREATED PER PDR17011

ALL INFORMATION ILLUSTRATED IS THE PROPERTY OF CONXALL CORPORATION. UNAUTHORIZED DUPLICATION OR DISTRIBUTION OF THIS DOCUMENT IS PROHIBITED.

UNLESS OTHERWISE SPECIFIED TOLERANCES:
 3 PLACE DECIMALS ±.005
 ANGLES ±1°
 FRACTIONS ±1/16

ALL UNITS ARE IN FEET, INCHES, FRACTION OF INCHES AND DECIMALS

FILE: SF8382-XPG-5XX
 DIRECTORY: SLW

SCALE: NTS
 SIZE: B
 SHEET: 1 OF 2

TITLE: CABLE-TO-CABLE ASSEMBLY (2-6) #16 PIN CONTACTS, SOLDER SHIELDED MINI-CON-X STANDARD PRODUCT

CUSTOMER: SF8382-XPG-5XX

REV: A

RoHS COMPLIANT

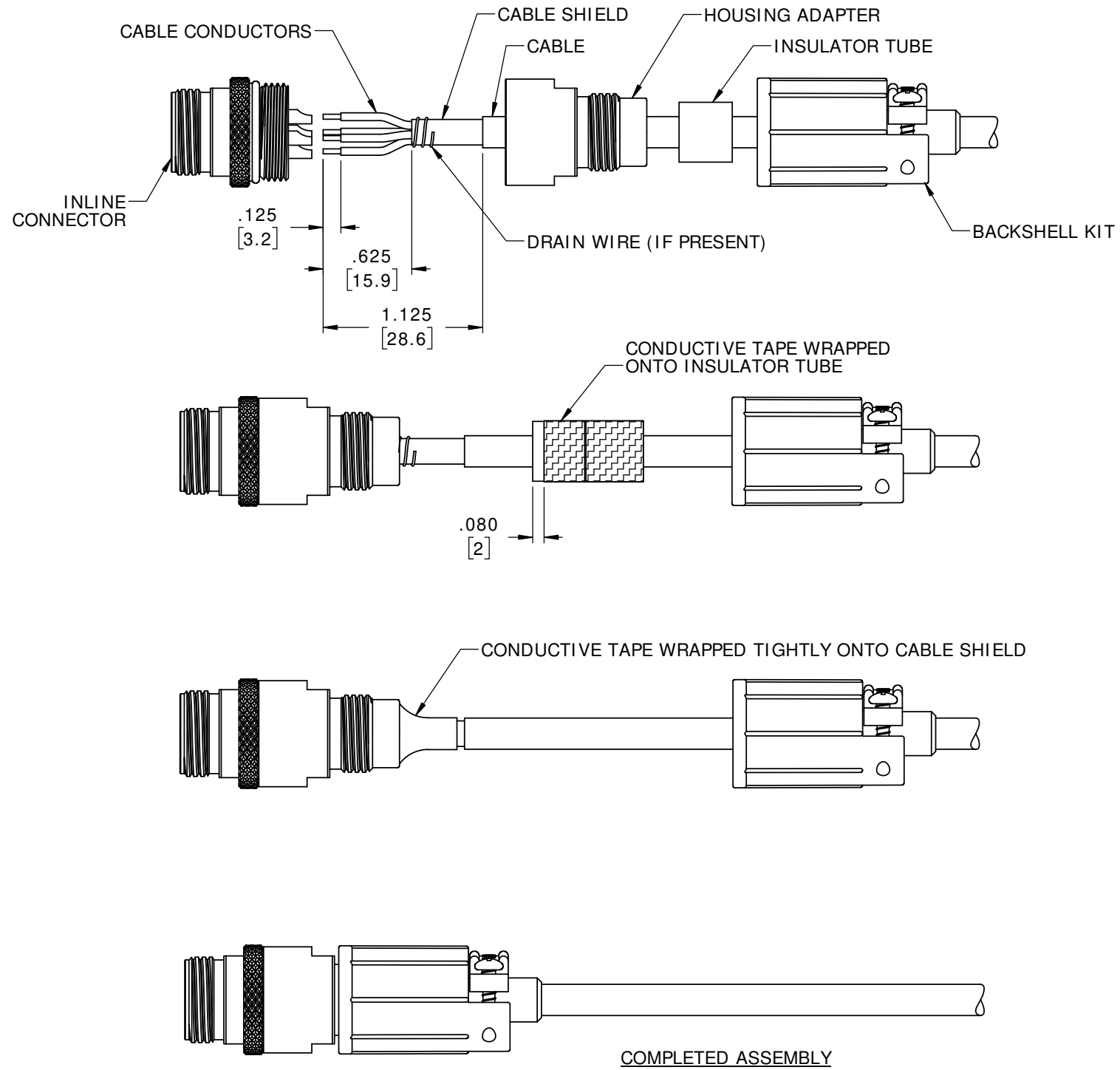

CABLE WIRING AND ASSEMBLY INSTRUCTIONS:

STEP 1. SLIDE HOUSING ADAPTER, INSULATOR TUBE, AND BACKSHELL KIT, ONTO CABLE IN THE ORDER SHOWN.

STEP 2. STRIP CABLE JACKET AND WIRES TO LENGTH. EXCESS CABLE SHIELD MUST BE TRIMMED OR WRAPPED AROUND WIRES. IF PRESENT, USE THE DRAIN WIRE TO WRAP THE CABLE SHIELD IN PLACE.

STEP 3. SOLDER WIRES TO CONTACTS.

STEP 4. THREAD HOUSING ADAPTER ONTO CONNECTOR AND TIGHTEN TO 5 LB-IN [0.56 N-m] MINIMUM TORQUE.

STEP 5. PEEL-OFF THE BACKING OF THE CONDUCTIVE TAPE AND WRAP IT AROUND THE INSULATOR AS SHOWN.

STEP 6. SLIDE INSULATOR/CONDUCTIVE TAPE INTO THE BACK OF THE CONNECTOR. FORM FREE END OF CONDUCTIVE TAPE TIGHTLY ONTO THE SHIELD OF THE CABLE.

STEP 7. SLIDE AND THREAD THE BACKSHELL KIT ONTO CONNECTOR. TIGHTEN TO 5 LB-IN [0.56 N-m] MINIMUM TORQUE.

STEP 8. TIGHTEN THE TWO BACKSHELL SCREWS TO SECURE THE CABLE IN THE BACKSHELL.

MA	04-03-19	RELEASED PER PDR 17011	
A	PNK	12-20-18	O-RING 4290S REPLACES SF6290S-1.
	PNK	1-30-18	DRAWING CREATED PER PDR 17011
REV.	INIT.	DATE	DESCRIPTION
ALL INFORMATION ILLUSTRATED IS THE PROPERTY OF CONXALL CORPORATION. UNAUTHORIZED DUPLICATION OR DISTRIBUTION OF THIS DOCUMENT IS PROHIBITED.		ORIG. DRAWN BY: PNK	DATE: 1-30-18
UNLESS OTHERWISE SPECIFIED TOLERANCES 3 PLACE DECIMALS ±.005 ANGLES ±1° FRACTIONS ±1/16		CHECKED BY:	 601 E. WILDWOOD VILLA PARK, IL 60181
▷ - CRITICAL CHARACTERISTIC FLAG PER SPEC. XXXX		APPROVED BY:	
SCALE	SIZE	SHEET	TITLE:
NTS	B	2 OF 2	CABLE-TO-CABLE ASSEMBLY (2-6) #16 PIN CONTACTS, SOLDER SHIELDED MINI-CON-X STANDARD PRODUCT
FILE:	DIRECTORY:	PART NUMBER:	CUSTOMER:
FILE NAME	SLW	SF8382-XPG-5XX	STANDARD PRODUCT
			REV A