

Motor and Pump Protection Relays

MPS Series

Motor Protection System



Description

The MPS Motor Protection System monitors voltage, current, and temperature to provide a comprehensive package of 22 protective functions. The MPS is a modular system with integrated protection, motor control, metering, and data-logging functions. This system is typically used to provide protection for three-phase low- and medium-voltage, medium- to high-horsepower induction motors.

1 Operator Interface (MPS-OPI)

- Large, bright, 4 x 20 vacuum-fluorescent display
- Display metered values
- Access set points
- Powered by Control Unit
- Panel mount or attach directly to Control Unit
- Remote mounting (1.2 km or 4000 ft maximum loop length)
- ½ DIN size
- Hazardous-location certified

2 Control Unit (MPS-CTU)

- Current inputs—5-A or 1-A secondary phase current transformers
- Voltage inputs—up to 600 V without PTs
- Earth-leakage input—5-A or 1-A secondary or sensitive transformer
- Tachometer (high-speed pulse) input
- 8 digital inputs, 5 relay outputs, 1 analog input and output
- 24-Vdc supply for OPI and RTD modules, and for digital inputs
- IRIG-B time-code input
- ½ DIN size, surface mount
- RS-485 network communications (Standard)
- DeviceNet™, Profibus®, or Ethernet communications available

Features & Benefits

FEATURES	IEEE #	BENEFITS
Overload	49, 51	Extends motor life and prevents insulation failures and fires
Current unbalance/Phase loss/Phase reverse	46	Prevents overheating and extends motor life
Overcurrent/Jam	50, 51	Prevents catastrophic failures and fires and extends motor life
Ground fault	37	Detects low-level or no-load conditions
RTD temperature	50G/N, 51G/N	Prevents catastrophic failures and fires
Overvoltage	38, 49	Optional RTD temperature protection (MPS-RTD module) for high ambient or loss of ventilation protection
Undervoltage	59	Prevents stress to insulation
Voltage unbalance	27	Prevents a start attempt when it will damage the motor
Phase differential	47	Detects unhealthy supply voltage
Dynamic thermal model	87	Provides sensitive protection for high-resistance winding faults
Reduced overcurrent model		Provides protection through starting, running, overload, and cooling cycles
Starter control		Minimizes arc-flash hazards during maintenance

Motor and Pump Protection Relays

MPS Series

Applications

- Motor protection

Specifications

Protective Functions (IEEE Device Numbers)

Overload (49, 51), Phase reverse (current) (46), Overfrequency (81), Overcurrent (50, 51), Jam, Underfrequency (81), Ground fault (50G/N, 51G/N), Undercurrent (37), Unbalance (voltage) (47), Failure to accelerate, RTD temperature (38, 49), Unbalance (current) (46), Underspeed (14), Starts per hour (66), Phase loss (voltage) (47), Overvoltage (59), Differential (87), Phase loss (current) (46), Undervoltage (27), Phase reverse (voltage) (47), Power factor (55)

Input Voltage

65-265 Vac, 25 VA; 80-275 Vdc, 25 W

Power-Up Time

800 ms at 120 Vac

Ride-Through Time

100 ms minimum

24-Vdc Source

100 mA maximum

AC Measurements

True RMS and DFT, Peak, 16 samples/cycle, and positive and negative sequence of fundamental

Frequency

50, 60 Hz or ASD

Inputs

Phase current, Earth-leakage current, Phase voltage, 7 digital, tachometer, 1 analog

Output Contacts

5 contacts — See Product Manual

Communications

Allen-Bradley® DFI and Modbus® RTU (Standard); DeviceNet™, Ethernet (Optional)

Conformally Coated

Standard feature

Warranty

10 years

Control Unit Mounting

Surface

Operator Interface Mounting

Panel, Control-Unit mounted

Certification & Compliance

CSA	CSA Certified (CSA C22.2 No. 14, CSA C22.2 No. 213-M1987 (OPI and RTD modules only), CSA E60079-15:02 (RTD module only))
RCM	RCM
UL	UL Recognized (UL 60947-4-1, UL 1053, UL 60079-15 (RTD module only))

Accessories

A Phase Current Transformers

Phase CTs are required to detect phase currents.

B Ground-Fault Current Transformer

Required zero-sequence current transformer detects ground-fault current. Available with 5-A and 30-A primary ratings for low-level pickup.

C MPS-RTD Temperature Input Module

Optional module provides 8 inputs to connect Pt100, Ni100, Ni120, and Cu10 RTDs.

Ordering Information

ORDERING NUMBER	COMMUNICATIONS
MPS-CTU-01-00	RS-485
MPS-CTU-02-00	RS-485 & DeviceNet™
MPS-CTU-04-00	RS-485 & EtherNet/IP™ & Modbus® TCP

Motor and Pump Protection Relays

MPS Series

Ordering Information

ACCESSORIES	REQUIREMENT
MPS-OPI-01-00	Recommended
Phase CTs	Required
Ground-Fault CT	Recommended
MPS-RTD-01-00	Optional

Simplified Wiring Diagram

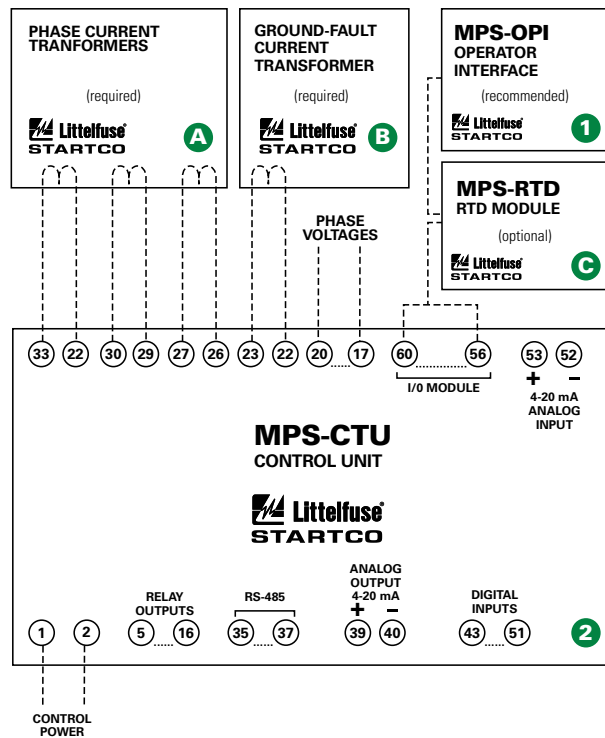

Simplified Circuit Diagram

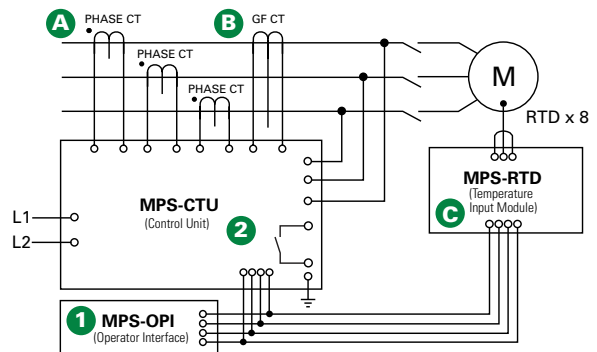

Disclaimer Notice – Information furnished is believed to be accurate and reliable. However, users should independently evaluate the suitability of and test each product selected for their own applications. Littelfuse products are not designed for, and may not be used in, all applications. Read complete Disclaimer Notice at www.littelfuse.com/product-disclaimer.