

THE INFORMATION CONTAINED HEREIN IS CONSIDERED "PROPRIETARY" TO BEL FUSE INC. AND SHALL NOT BE COPIED, REPRODUCED OR DISCLOSED WITHOUT THE WRITTEN APPROVAL OF BEL FUSE INC.



DOCUMENT / PART NO.: SI-46001-F

TITLE : 10/100BT, VERTICAL, SHIELDED

ISSUE	DESCRIPTION OF CHANGE												REVIEWED BY	APPROVED BY	ECN#		
A0	Use new format and production release.												David Chan	Steve Weller	06295		
B0	correct the footprint dimension												Karen Snyder	Steve Weller	06307		
PAGE	1	2	3	--	--	--	--	--	--	--	--	--	--	--	--	--	--
REV.	B0	B0	B0	--	--	--	--	--	--	--	--	--	--	--	--	--	--
PAGE	--	--	--	--	--	--	--	--	--	--	--	--	--	C0215-F REV A0			
REV.	--	--	--	--	--	--	--	--	--	--	--	--	--	24-0247-F REV B0			

THE INFORMATION CONTAINED HEREIN IS CONSIDERED "PROPRIETARY" TO BEL FUSE INC. AND SHALL NOT BE COPIED, REPRODUCED OR DISCLOSED WITHOUT THE WRITTEN APPROVAL OF BEL FUSE INC.



ELECTRICAL CHARACTERISTICS @ 25°C

- 1.0 TURNS RATIO: (P6-P5-P4) : (J6-J3) : 1CT : 1CT ± 3%
(P3-P2-P1) : (J2-J1) : 1CT : 1CT ± 3%
- 2.0 INDUCTANCE: (P6-P4) : 350uH MIN. @ 0.1V, 100KHZ, 8mA DC Bias
(P3-P1) : 350uH MIN. @ 0.1V, 100KHZ, 8mA DC Bias
- 3.0 LEAKAGE INDUCTANCE: P6-P4 (WITH J6 AND J3 SHORT) : 0.3uH MAX. @ 1MHZ
P3-P1 (WITH J2 AND J1 SHORT) : 0.3uH MAX. @ 1MHZ
- 4.0 INTERWINDING CAPACITANCE: (P6,P5,P4) TO (J6,J3) : 30pF MAX. @ 1MHZ
(P3,P2,P1) TO (J2,J1) : 30pF MAX. @ 1MHZ
- 5.0 DC RESISTANCE: (J6-J3)=(J2-J1) : 1.2 ohms Max.
- 6.0 RETURN LOSS: (P6-P4)=100 OHMS AND (P1-P3)=100 OHM REF.
1MHz TO 30MHz : 18dB MIN.
60MHz TO 80MHz : 12dB MIN.
NOTE: 100 OHMS CONNECTED TO (J2-J1) OR (J6-J3).
- 7.0 VOLTAGE WITHSTAND: (J1, J2) TO (P1, P3) : 1500 Vrms
(J3, J6) TO (P4,P6) : 1500 Vrms
- 8.0 INSERTION LOSS: RS=RL=100 ohms
100KHz TO 100MHz : 1.1 dB TYP
- 9.0 RISE TIME: RS=100 OHMS AND RL = 100 OHMS
OUTPUT VOLTAGE = 1 V peak : 3.0 nS MAX
PULSE WIDTH= 112nS : 3.0 nS MAX
- 10.0 CROSS TALK: 1MHz TO 100MHz : 40 dB TYP
- 11.0 COMMON TO COMMON MODE ATTENUATION:
30MHz TO 100MHz : 35dB TYP

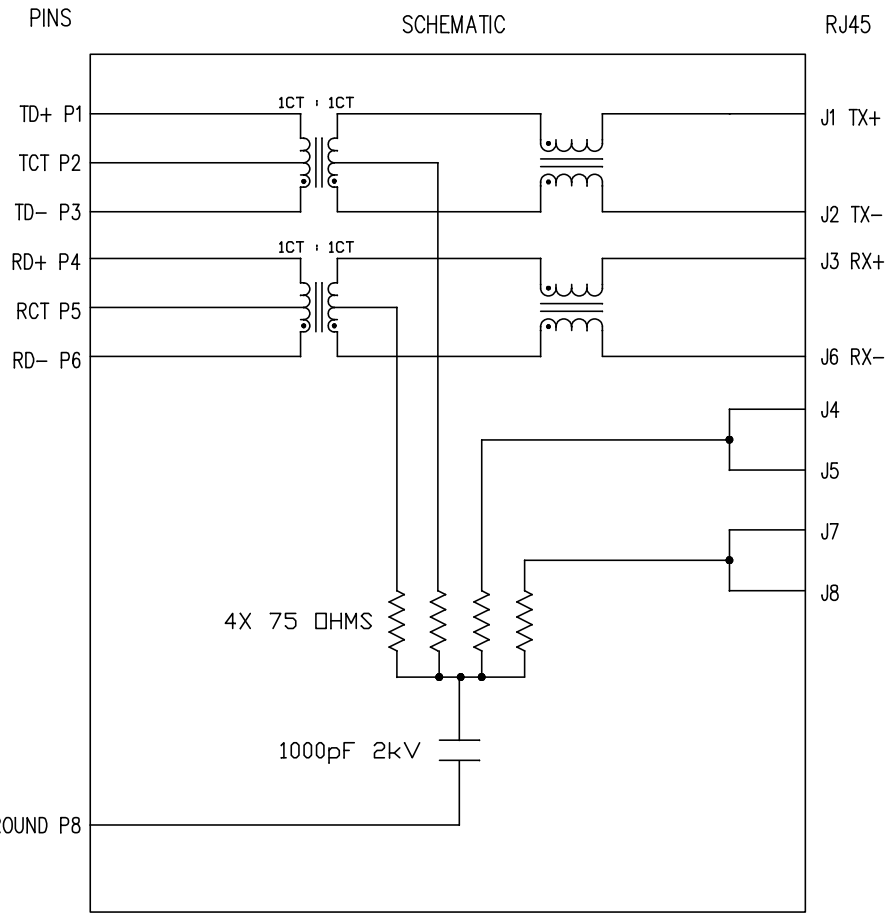

NOTES: 1.0 PINS WITHOUT ELECTRICAL CONNECTION ARE OMITTED.

ORIGINATED BY	DATE	TITLE	PART NO. / DRAWING NO.	STANDARD DIM.	[] METRIC DIM. AS REFERENCE	
Bain Liu	04-23-09	 10/100BT VERTICAL, SHIELDED	SI-46001-F	TOL. IN INCH	UNIT : INCH [mm]	REV. : B0
DRAWN BY	DATE		FILE NAME	.X	SCALE : N/A	SIZE : A4
R.S.Zhang	04-23-09		SI-46001-F.DWG	.XX	±0.005	PAGE : 2



THE INFORMATION CONTAINED HEREIN IS CONSIDERED "PROPRIETARY" TO BEL FUSE INC. AND SHALL NOT BE COPIED, REPRODUCED OR DISCLOSED WITHOUT THE WRITTEN APPROVAL OF BEL FUSE INC.

RoHS
2002/95/EC

LED POLARITY
(ENLARGED VIEW)



SINGLE COLOR LED

LED SPECIFICATION			
STANDARD LED	WAVELENGTH	FORWARD V (MAX)	η(TYP)
GREEN	565 nm	2.5 V	2.2 V
YELLOW	590 nm	2.5 V	2.1 V

*WITH A FORWARD CURRENT OF 20 mA (TYP)

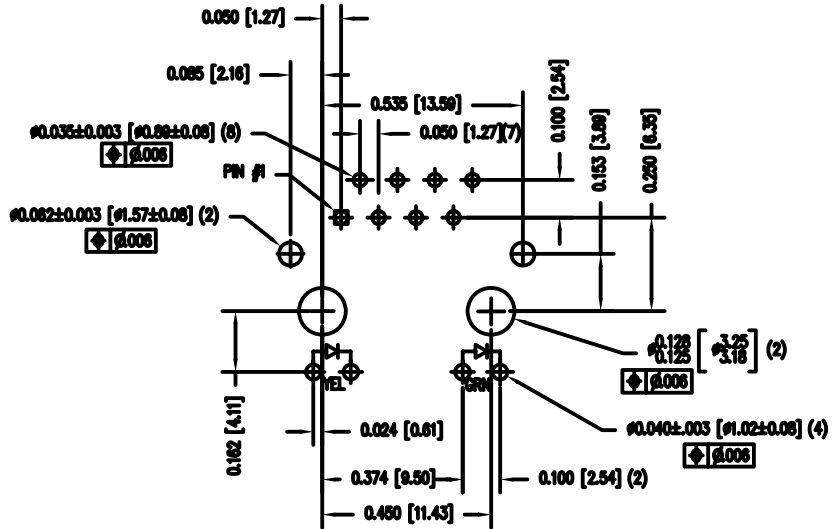
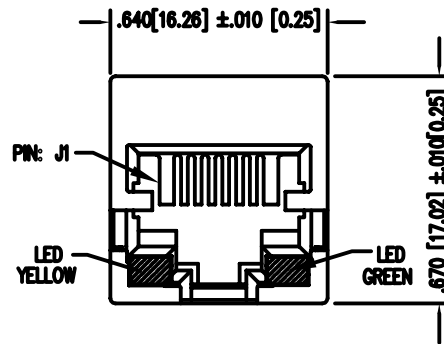
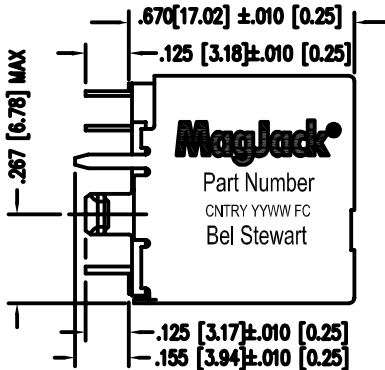

P.C.B. RECOMMENDED HOLE LAYOUT
SEEN FROM COMPONENT SIDE

ALL CENTERLINE DIMENSIONS ARE BASIC

NOTES:

- CONNECTOR MATERIALS:
HOUSING: THERMOPLASTIC UL94 V-0
CONTACT/SHIELD: COPPER ALLOY
SHIELD PLATING: NICKEL OR TIN
CONTACT PLATING: SELECTIVE GOLD,
50 MICRO-INCHES MIN. IN CONTACT AREA.
- PIN NOT ELECTRICALLY CONNECTED MAYBE OMITTED.
SEE ELECTRICAL DRAWING FOR OMITTED PINS.
- TOLERANCES COMPLY WITH F.C.C. DIMENSION REQUIREMENTS.
- ALL TOLERANCES NOT OTHERWISE SPECIFIED TO BE ±.005 [0.13]
- WAVE SOLDER COMPATIBLE - PREHEAT 125°C/90SECS.

ORIGINATED BY	DATE	TITLE	PART NO. / DRAWING NO.	STANDARD DIM. TOL. IN INCH	[] METRIC DIM. AS REFERENCE
Bain Liu	04-23-09	 10/100BT VERTICAL, SHIELDED	SI-46001-F	X	UNIT : INCH [mm] REV. : 80
DRAWN BY	DATE		FILE NAME	XX	SCALE : N/A SIZE : A4
R.S.Zhang	04-23-09		SI-46001-F.DWG	XXX ±0.005	PAGE : 3

