



## EAR-001 & EAR-002 MODELS

SIL3 PLe SAFETY ENCODER SIGNAL SPLITTERS

### Introduction

The Functional Safety splitter is a certified data interface that is designed to integrate into a safety loop.

Its construction allows it to easily integrate an encoder with safety motion controllers, while also providing a secondary set of data outputs for a standard motion controller. The primary signal from the splitter is 100% compatible with BEI Sensors/Sensata Safety motion controllers and safety relays. While the secondary signal (or repeater) provides encoder signals for an additional industrial grade (non-Functional Safety) motion controller (drive, display, PLC, etc.)



### Features

- Usable with standard and Safety encoders
- Suitable for simultaneous safe and non-safe motor feedback connections
- TTL/RS422, HTL or sine 1Vpp encoder interfaces
- Safe output: same as connected encoder interface
- Non-safe output: TTL/RS422 or HTL user selectable
- Power supply for encoders: 5Vdc or 11-30Vdc user selectable

### Applications

- Automated machine tools
- Safety lock-out systems
- Robotic assembly
- Conveyor and web-based systems (packaging, inspection, cartonizing)

## SPECIFICATIONS

### Mechanical

	EAR-001	EAR-002
<b>Housing Material</b>	Polyamid, red color	
<b>Dimensions (W x H x D)</b>	22.5 x 108 x 114.5mm	
<b>Fixing mode</b>	DIN rail	
<b>Weight</b>	140g	

### Electrical

	EAR-001	EAR-002
<b>Splitter power supply +Vin</b>	11-30Vdc  250mA (*)	
<b>Encoder power supply</b>	Selectable : +Vin or 5Vdc, 200mA max.	+Vin, 200mA max.
<b>Max encoder frequency</b>	300kHz	
<b>Encoder input</b>	TTL/RS422 or sine 1Vpp	HTL
<b>Safe output (Direct encoder signals transmission)</b>	Same as interfaced encoder	HTL
<b>Secondary output (Not safety rated)</b>	Selectable: TTL/RS422 or HTL	
<b>Encoder input connection</b>	Terminal blocks	

<b>Secondary output connection</b>	Terminal blocks
<b>Safe output connection</b>	RJ45 connector

(\*) Device must be supplied by a Class 2 LPS or SELV/PELV limited energy source ≤60V.

## Functional Safety Parameters

The splitter does not contribute to the overall failure rate (safety chain) since it has no known failure modes or diagnostics. The safety-related parameters are dependent on the connected encoder and safety controller and can reach up to SIL 3 / PLe Cat 4.

## Environmental & Standards Conformity

<b>Protection (EN 60529)</b>	IP20
<b>Humidity (EN 60068-2-38)</b>	93% @ 65°C for electronics (Housing may show mechanical deformations when cumulating high humidity with high temperature cycles)
<b>Shock (EN60068-2-27)</b>	300m.s <sup>-2</sup> (during 11 ms)
<b>Vibration (EN60068-2-6)</b>	Amplitude 3.5 mm or acceleration 50 m.s <sup>-2</sup> (10 ... 200 Hz)
<b>Operating temperature</b>	-20°C to +65°C
<b>Storage temperature</b>	-20°C to +70°C
<b>EMC Immunity Test</b>	EN 61000-6-2:2016, increased levels in accordance with IEC 62061
<b>EMC Emission Test</b>	EN 61000-6-4:2018, increased levels in accordance with IEC 62061
<b>Isolation</b>	500 Veff
<b>Functional safety</b>	IEC 61508
	IEC 62061
	ISO 13849-1
	IEC 61800-5-2
<b>Splitters usable up to SIL3 / PLe with specific requirements, see safety user manual for details.</b>	

## Electrical Connections

<b>RJ45 Wiring (SAFE output)</b>		
<b>PIN</b>	<b>SIGNAL</b>	<b>EAR-001 &amp; EAR-002 FUNCTION</b>
<b>1</b>	+V ENCODER	Encoder power supply +V output for monitoring purpose
<b>2</b>	0V	Encoder power supply 0V
<b>3</b>	N/C	Reserved
<b>4</b>	A ENCODER	A signal - SAFE output
<b>5</b>	A/ ENCODER	A/ signal - SAFE output
<b>6</b>	N/C	Reserved
<b>7</b>	B ENCODER	B signal - SAFE output
<b>8</b>	B/ ENCODER	B/ signal - SAFE output

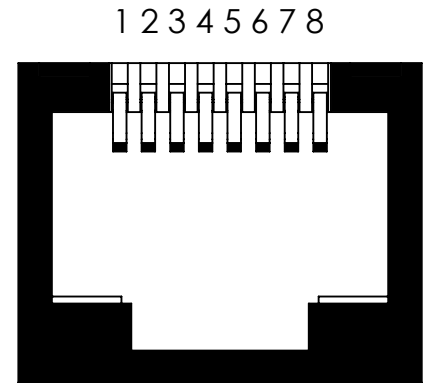

Terminal blocks wiring			
PIN	SIGNAL	EAR-001 FUNCTION	EAR-002 FUNCTION
1	+Vin		Splitter power supply : +24Vdc
2	Z SECONDARY		Z signal - SECONDARY output
3	Z/ SECONDARY		Z/ signal - SECONDARY output
4	0V		Splitter power supply ground
5	+V ENCODER		Encoder power supply output
6	Z ENCODER		Z signal - ENCODER input
7	Z/ ENCODER		Z/ signal - ENCODER input
8	0V ENCODER		Encoder power supply: 0V (internally connected to PIN 4)
9	A SECONDARY		A signal - SECONDARY output
10	A/ SECONDARY		A/ signal - SECONDARY output
11	B SECONDARY		B signal - SECONDARY output
12	B/ SECONDARY		B/ signal - SECONDARY output
13	A ENCODER		A signal - ENCODER input
14	A/ ENCODER		A/ signal - ENCODER input
15	B ENCODER		B signal - ENCODER input
16	B/ ENCODER		B/ signal - ENCODER input
17 18 19	SECONDARY output selection		Pin 18 connected to 17 = TTL/RS422 (factory jumper preconfiguration) Pin 18 connected to 19 = HTL
20	SHIELD		SECONDARY output cable shield connection
21 22 23	ENCODER power supply selection		Pin 22 connected to 21 = +5Vdc (factory jumper preconfiguration) Pin 22 connected to 23 = +24Vdc
24	SHIELD		Encoder cable shield connection

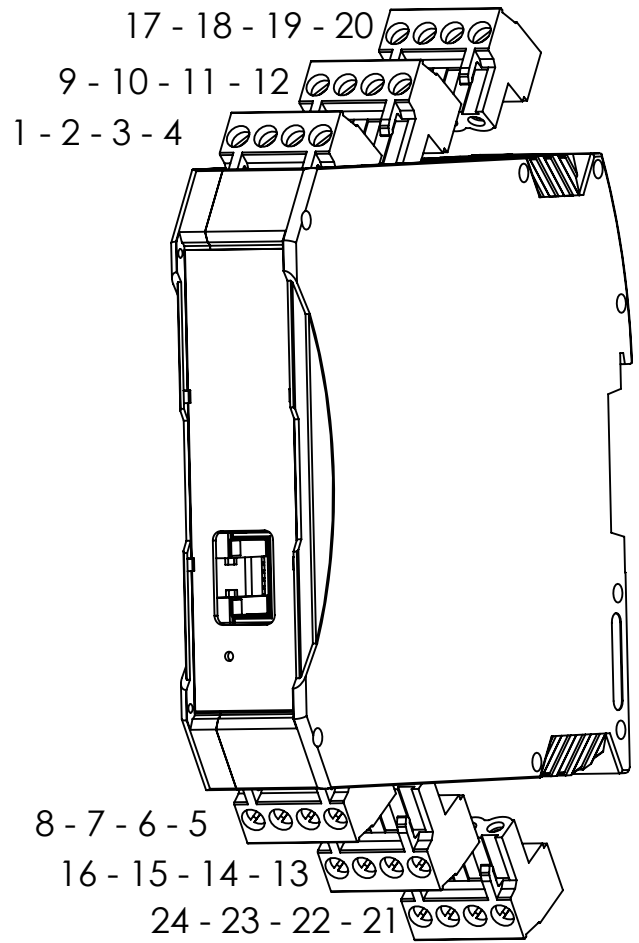

## DIMENSIONS

Dimensions are in millimeters

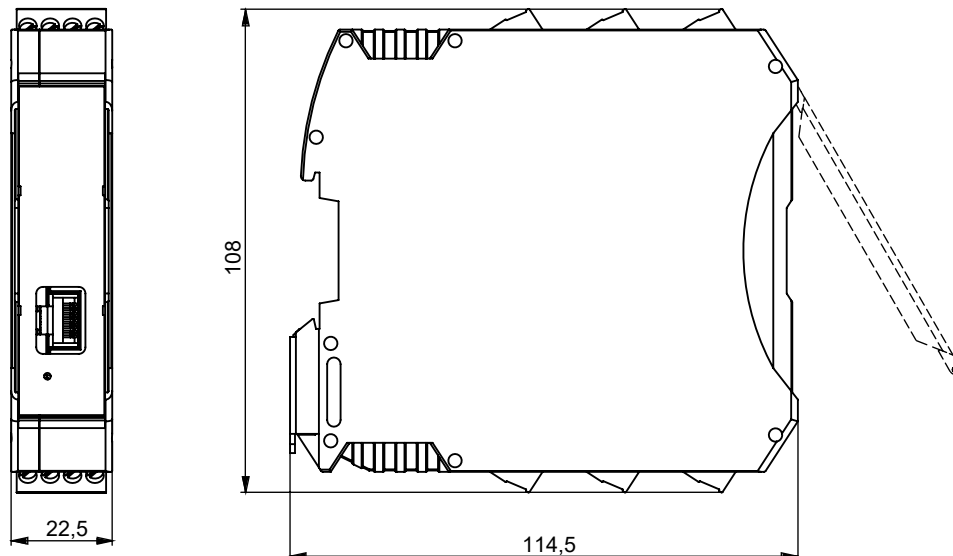



## INSTALLATION

1. Clip the splitter on the DIN rail.
2. Check the power supply is switched off and make the terminal blocks electrical connections per wiring table printed on the product.
3. Check or configure the jumpers' positions.
4. Plug the RJ45 cord from the splitter to the safety motion controller.
5. Power on the devices.

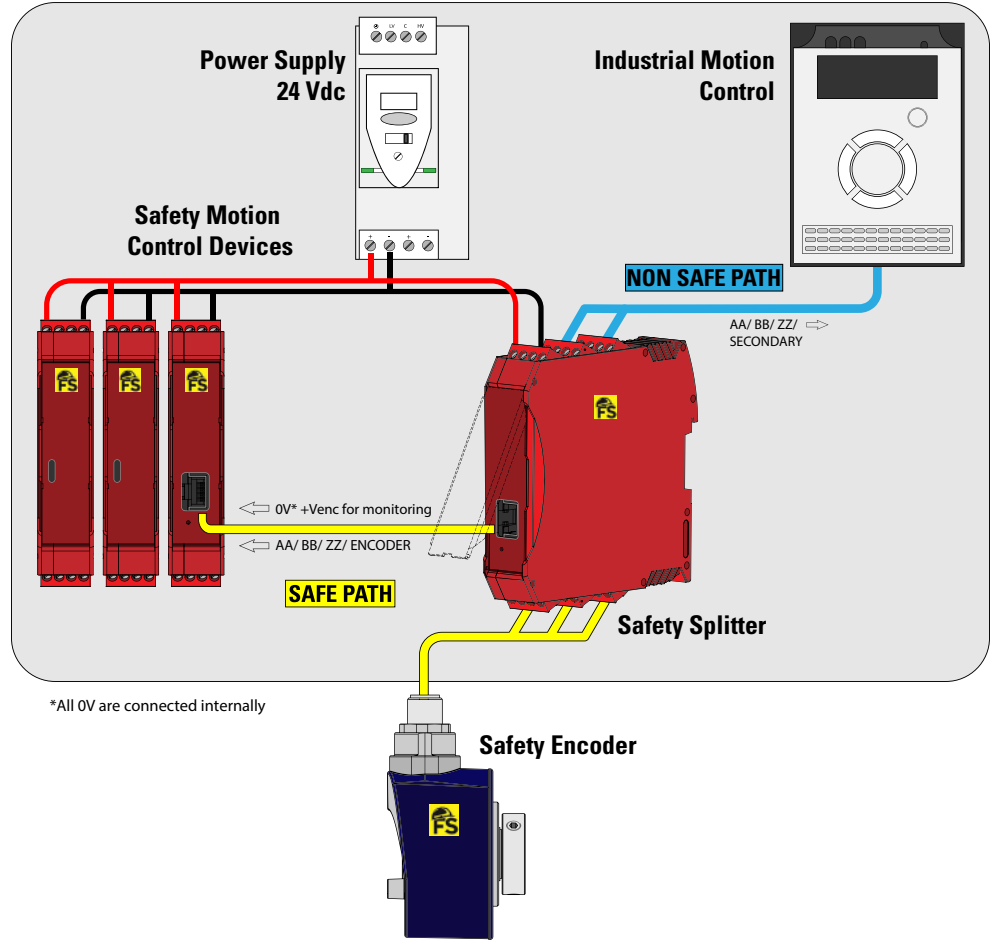

Splitters in association with RJ45 cables (see accessories section) are compatible with safety motion controllers from BEI Sensors partners:

- EAR-001 can be connected to NEG0003001 and NEG0003002. Safety module Interface sine/cosine and TTL respectively - consult factory
- EAR-002 can be connected to NEG0003003. Safety module interface HTL - consult factory
- Other safety motion controllers with adapted RJ45 cable assemblies



## GENERAL NOTES

**For a safe installation according to the required safety level needed in the application, refer to the user safety User Manual. The safety User Manual provides the technical information (drawings, electrical data, etc...) for a safe integration.**



## ORDERING OPTIONS

Example : EAR-001



**001:** Splitter for TTL/RS422 or sine 1Vpp encoder interface  
**002:** Splitter for HTL encoder interface



## AGENCY APPROVALS & CERTIFICATIONS



### BEI Sensors SAS Sensata Technologies

Espace Européen de l'Entreprise  
9, rue de Copenhague  
B.P. 70044 Schiltigheim  
F 67013 Strasbourg Cedex

Tél : +33 (0)3 88 20 80 80  
Fax : +33 (0)3 88 20 87 87  
Mail : position-info.eu@sensata.com  
Web : www.sensata.com

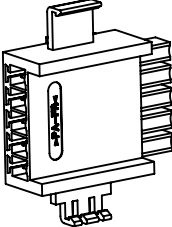
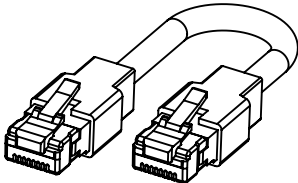

## ACCESSORIES

Description	Part Number
<b>Jumper (Included)</b> 	8213/105
<b>Bus Connector (Ordered separately)</b> 	NEG0003008
<b>RJ45 Connection to safety module (Ordered separately)</b> 	NEG0003010 = RJ45 - cable 0.15m - RJ45 NEG0003011 = RJ45 - cable 0.30m - RJ45 NEG0003012 = RJ45 - cable 0.50m - RJ45

Sensata Technologies, Inc. ("Sensata") data sheets are solely intended to assist designers ("Buyers") who are developing systems that incorporate Sensata products (also referred to herein as "components"). Buyer understands and agrees that Buyer remains responsible for using its independent analysis, evaluation and judgment in designing Buyer's systems and products. Sensata data sheets have been created using standard laboratory conditions and engineering practices. Sensata has not conducted any testing other than that specifically described in the published documentation for a particular data sheet. Sensata may make corrections, enhancements, improvements and other changes to its data sheets or components without notice.

Buyers are authorized to use Sensata data sheets with the Sensata component(s) identified in each particular data sheet. HOWEVER, NO OTHER LICENSE, EXPRESS OR IMPLIED, BY ESTOPPEL OR OTHERWISE TO ANY OTHER SENSATA INTELLECTUAL PROPERTY RIGHT, AND NO LICENSE TO ANY THIRD PARTY TECHNOLOGY OR INTELLECTUAL PROPERTY RIGHT, IS GRANTED HEREIN. SENSATA DATA SHEETS ARE PROVIDED "AS IS". SENSATA MAKES NO WARRANTIES OR REPRESENTATIONS WITH REGARD TO THE DATA SHEETS OR USE OF THE DATA SHEETS, EXPRESS, IMPLIED OR STATUTORY, INCLUDING ACCURACY OR COMPLETENESS. SENSATA DISCLAIMS ANY WARRANTY OF TITLE AND ANY IMPLIED WARRANTIES OF MERCHANTABILITY, FITNESS FOR A PARTICULAR PURPOSE, QUIET ENJOYMENT, QUIET POSSESSION, AND NON-INFRINGEMENT OF ANY THIRD PARTY INTELLECTUAL PROPERTY RIGHTS WITH REGARD TO SENSATA DATA SHEETS OR USE THEREOF.

All products are sold subject to Sensata's terms and conditions of sale supplied at [www.sensata.com](http://www.sensata.com) SENSATA ASSUMES NO LIABILITY FOR APPLICATIONS ASSISTANCE OR THE DESIGN OF BUYERS' PRODUCTS. BUYER ACKNOWLEDGES AND AGREES THAT IT IS SOLELY RESPONSIBLE FOR COMPLIANCE WITH ALL LEGAL, REGULATORY AND SAFETY-RELATED REQUIREMENTS CONCERNING ITS PRODUCTS, AND ANY USE OF SENSATA COMPONENTS IN ITS APPLICATIONS, NOTWITHSTANDING ANY APPLICATIONS-RELATED INFORMATION OR SUPPORT THAT MAY BE PROVIDED BY SENSATA.

Mailing Address: Sensata Technologies, Inc., 529 Pleasant Street, Attleboro, MA 02703, USA.

## CONTACT US

### Americas

+1 (800) 350 2727 – Option 1  
sales.beisensors@sensata.com  
**Europe, Middle East & Africa**  
+33 (3) 88 20 8080  
position-info.eu@sensata.com

### Asia Pacific

sales.isasia@list.sensata.com  
China +86 (21) 2306 1500  
Japan +81 (45) 277 7117  
Korea +82 (31) 601 2004  
India +91 (80) 67920890  
Rest of Asia +886 (2) 27602006  
ext 2808