

PART NUMBER	REVISION	DESCRIPTION	FEED TYPE
2151569-2	F	FINE CRIMP HEIGHT ADJUST	PNEUMATIC
7-2151569-2	F	PNEUMATIC AND CRIMP TOOLING KIT	PNEUMATIC
7-2151569-7	F	CRIMP TOOLING KIT	-

ATLANTIC VERSION TERMINATOR INTERFACE ADAPTER

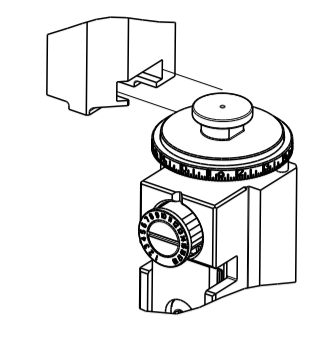

APPLICATOR DATA		
CRIMP	SIZE	TYPE
WIRE	2.03 mm [.080]	F
INSUL	6.35 mm [.250]	O

APPLICATOR INSTRUCTIONS 408-35042

TERMINAL DATA: TE TERMINAL		TE CRIMP SPECIFICATION	
TERMINAL NAME: TAB 5.8 x 0.8 mm TYP A			
WIRE STRIP LENGTH		INSULATION DIAMETER RANGE	
4.00-4.60 mm [.157-.181 IN]		Ø 6.00 MAX [.236 IN MAX]	
TERMINAL APPLICATION SPECIFICATION	114-18052		
TERMINALS APPLIED			
TE TERMINAL	TE TERMINAL	TE SEAL	SEAL INSULATION DIAMETER RANGE
964310-1	2-964310-2	963243-1	Ø 1.4-2.1 mm
		963244-1	Ø 2.2-3.0 mm

WIRE SIZE	CRIMP HEIGHT mm [INCH]	CRIMP HEIGHT REFERENCE SETTING
1.00mm2	1.56 +/- 0.05 [.061 +/- .002]	5.0
0.75mm2	1.47 +/- 0.05 [.058 +/- .002]	6.0
0.50mm2	1.38 +/- 0.05 [.054 +/- .002]	7.0

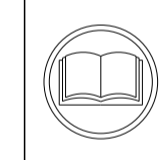

- RECOMMENDED SPARE PARTS.
- REFER TO SUPPLIED INSTRUCTION SHEET FOR CLEANING, LUBRICATION AND STORAGE OF APPLICATOR.
- APPLY PART NUMBER 2-23419-6 LOCTITE TO THREADS OF ITEMS 242.
- CRIMP HEIGHT REFERENCE SETTING WAS THE SETTING USED WHEN THE APPLICATOR WAS QUALIFIED AT THE FACTORY. ADJUSTMENT MAY BE NECESSARY WHEN RUNNING APPLICATOR IN THE FIELD.
- TERMINAL PITCH NOT COMPATIBLE WITH MECHANICAL FEED.
- APPLY TORQ-SEAL IN ALLEN SOCKET TO FILL HOLE AFTER FLAT HD HAS BEEN ADJUSTED TO CORRECT HEIGHT AT QUALIFICATION. APPLY #1-23419-5 LOC-TITE TO THREADS.
- 7. UNLESS SPECIFIED OTHERWISE TORQUE VALUES SHALL BE USED PER DOCUMENT, 101-35000.

***WARNING**
ON INSTALLATION, SET WIRE DISC TO CRIMP HEIGHT REFERENCE SETTING FOR LARGEST WIRE SIZE. CRIMP HEIGHT REFERENCE SETTINGS GREATER THAN THE VALUE SHOWN MAY CAUSE DAMAGE TO THE CRIMP TOOLING, REFER TO THE INSTRUCTION SHEET FOR PROPER SETUP AND ADJUSTMENTS.

ATLANTIC VERSION
Shown on sheets 1 of 4 & 2 of 4
(Pacific version shown on sheets 3 of 4 & 4 of 4)

LOC	DIST	REVISIONS			
A	66	REV	DATE	BY	APPD
		D1	ECR-21-007109	02AUG2021	AJ YY
		E	ECR-21-113713	14SEP2021	JWC GB
		F	ECR-22-154485	03OCT2022	TB JAH
		F1	ECR-22-155731	17OCT2022	FZ YY

-	1	1	2119641-1	FEED CAM, AIR FEED	248
-	1	1	2119082-6	CAM, SNAIL, INSULATION ADJUSTMENT	244
-	1	1	2079764-1	WASHER, WAVE SPRING, CREST-TO-CREST	243
-	1	1	2119083-1	RETAINER, INSULATION DIAL	242
-	1	1	7-18023-7	SCR, SKT HD CAP M3 X 4.0	241
-	1	1	2844940-1	AIR FEED MODULE	238
-	REF	REF	994970-2	COUNTER, MAGNETIC	164
-	1	1	1-22281-8	SPRING, COMPRESSION	121
-	1	1	1-18028-2	WASHER, FLAT, REG M4	119
-	1	1	2844908-1	SCREW, LOCKING	99
-	1	1	2844907-1	POST, LOCKING	98
-	1	1	2-690438-8	FRONT STRIP GUIDE	96
-	2	2	2168083-1	SCR, SKT HD CAP, RoHS, M3 X 8.0	95
-	1	1	2168083-6	SCR, SKT HD CAP, RoHS, M5 X 65	93
-	1	1	455888-5	SPACER, CRIMPER	82
-	1	1	1803607-3	DOCUMENTATION PACKAGE	71
-	1	1	2119740-1	TAG IDENTIFICATION	67
-	2	2	2168078-1	SCREW, DRIVE, RH, RoHS, 2 x .188	66
-	2	2	2-18032-5	SCR, SET, FLT PNT, M5 X 20.0	61
-	1	1	2168083-2	SCR, SKT HD CAP, RoHS, M4 X 8.0	60
-	1	1	5-18022-5	SCR, HEX HD CAP, M4 X 6.0	59
-	1	1	985575-3	SCR, FLT SKT HD CAP M3 X 10.0	57
-	1	1	1338685-1	PAWL, FEED	56
-	4	4	2168083-3	SCR, SKT HD CAP, RoHS, M4 X 12.0	54
-	2	2	2168083-3	SCR, SKT HD CAP, RoHS, M4 X 12.0	53
-	1	1	1803382-2	HOLD DOWN, SPRING LOADED	50
-	1	1	18023-9	SCR, SKT HD CAP M4 X 6.0	49
-	1	1	1803583-9	APPLICATOR BASIC ASSEMBLY, SF	46
-	1	1	1803515-1	RAM ASSEMBLY, SF ATLANTIC	44
-	1	1	1803602-1	SCR, BHSC, RoHS (M8 X 25)	41
-	1	1	1-1752356-1	SUPPORT, TERMINAL	34
-	2	2	2079383-5	SCR, BHSC, RoHS (M4 X 20)	33
-	2	2	3-2844962-2	SPACER, CYLINDRICAL, STRIP GUIDE	30
-	1	1	1-2844938-8	PLATE, STRIP GUIDE	29
-	1	1	455888-3	SPACER, CRIMPER	28
-	2	2	22283-1	SPRING, COMPRESSION	27
-	1	1	356835-1	LEVER, DRAG RELEASE	26
-	1	1	240792-1	DRAG, TERMINAL	25
-	1	1	1320928-6	STRIP GUIDE	24
-	1	1	980371-4	SCR, SKT HD SHLDR 5.0 DIA X 6.0	23
-	1	1	2168083-2	SCR, SKT HD CAP, RoHS, M4 X 8.0	21
-	1	1	1-18028-2	WASHER, FLAT, REG M4	20
-	1	1	2119533-1	STRIPPER, SIDE FEED	19
-	1	1	2119806-1	INSERT, SHEAR	13
-	1	1	3-22280-3	SPRING, COMPRESSION	12
-	1	1	1-356885-4	STOP, SHEAR	11
-	1	1	2-2119805-1	SHEAR HOLDER, FRONT	10
-	1	1	318707-7	FLOATING SHEAR, FRONT	9
-	1	2	1-1633131-9	ANVIL, COMBINATION .080	8
-	1	1	240641-3	SPACER	7
-	-	-	-	-	6
-	1	1	2119781-6	DEPRESSOR, SHEAR	5
-	1	1	2-238011-1	BLOCK, CRIMPER SPACER	4
-	1	2	1-1633996-0	CRIMPER, INSULATION SPECIAL	3
-	1	1	455888-8	SPACER, CRIMPER	2
-	1	2	1-456405-6	CRIMPER, WIRE PREMIUM	1

DIMENSIONS:		TOLERANCES UNLESS OTHERWISE SPECIFIED:		MATERIAL:		FINISH:	
mm	0 PLC ±	1 PLC ±	2 PLC ±	3 PLC ±	4 PLC ±	ANGLES ±	FINISH ±

OWN	H. HUANG	05FEB2013	TE Connectivity
CHK	S. XI	05FEB2013	Harrisburg, PA 17105-3608
APPD	S. XI	05FEB2013	
PRODUCT SPEC	Ocean Side Feed Applicator		
APPLICATION SPEC			
SIZE	CAGE CODE	DRAWING NO	RESTRICTED TO
A1	00779	2151569	
Customer Accessible Production Drawing			SCALE 1:2 SHEET 1 OF 4 REV F1

LOC	DIST	REVISIONS					
		P	LTN	DESCRIPTION	DATE	DWN	APVD
A	66	-	-	SEE SHEET 1	-	-	-

FEED TYPE

PNEUMATIC

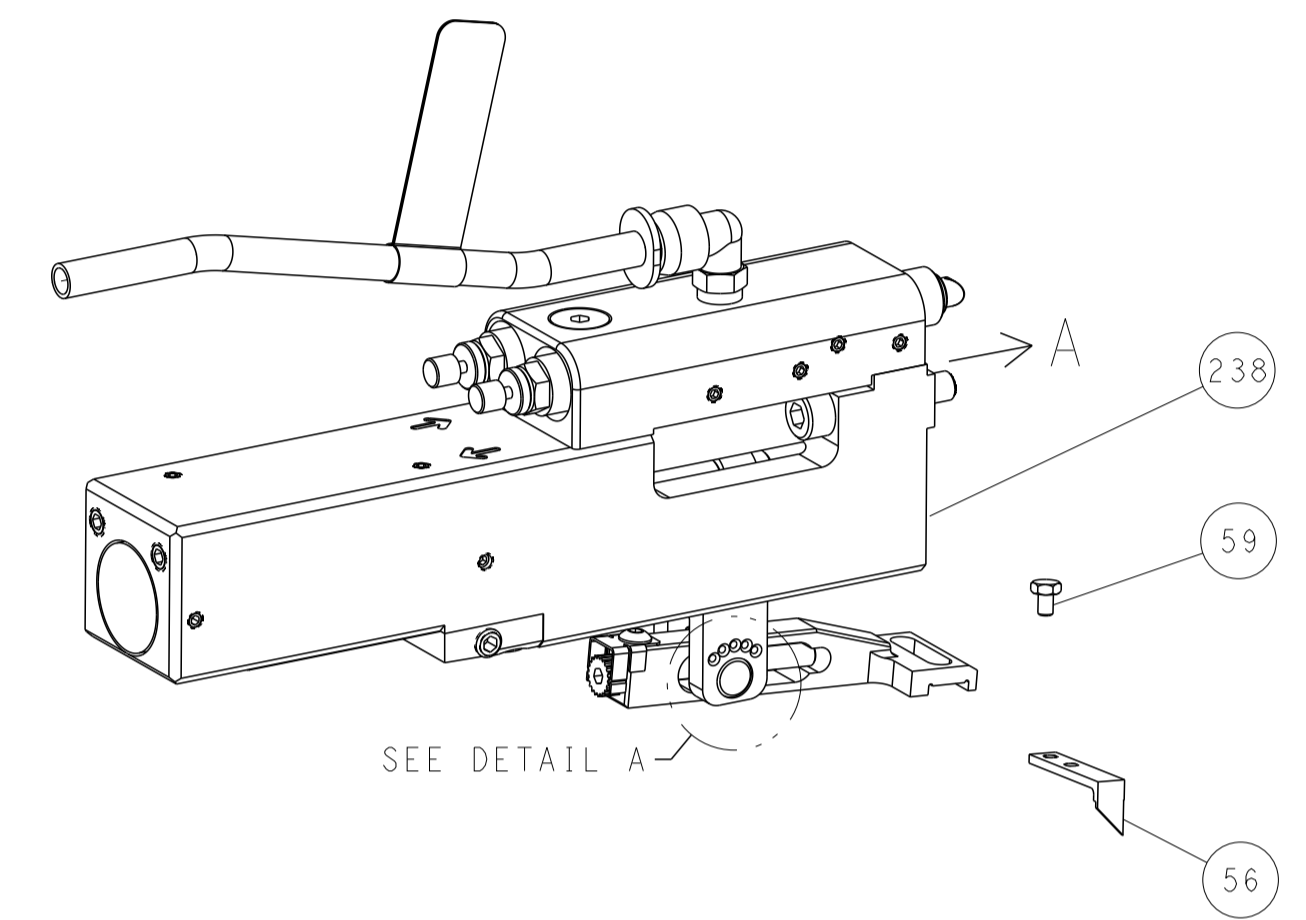

FEED SPRING SETTING POSITION (SHOWN FROM REAR SIDE)

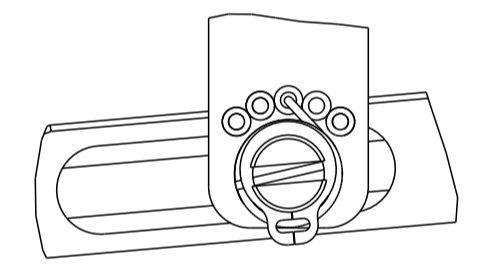

DETAIL A

CAM POSITION

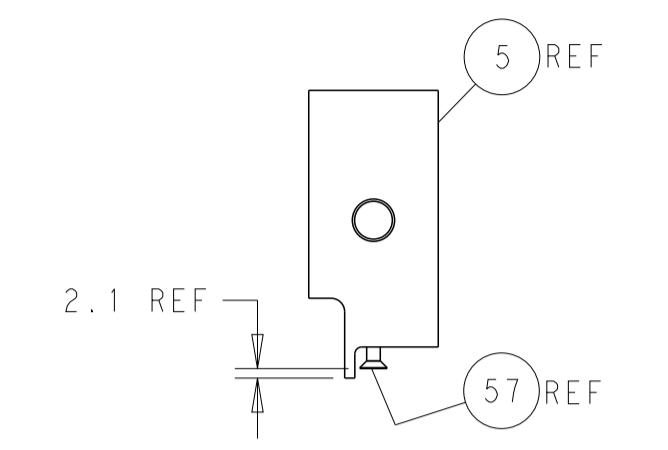
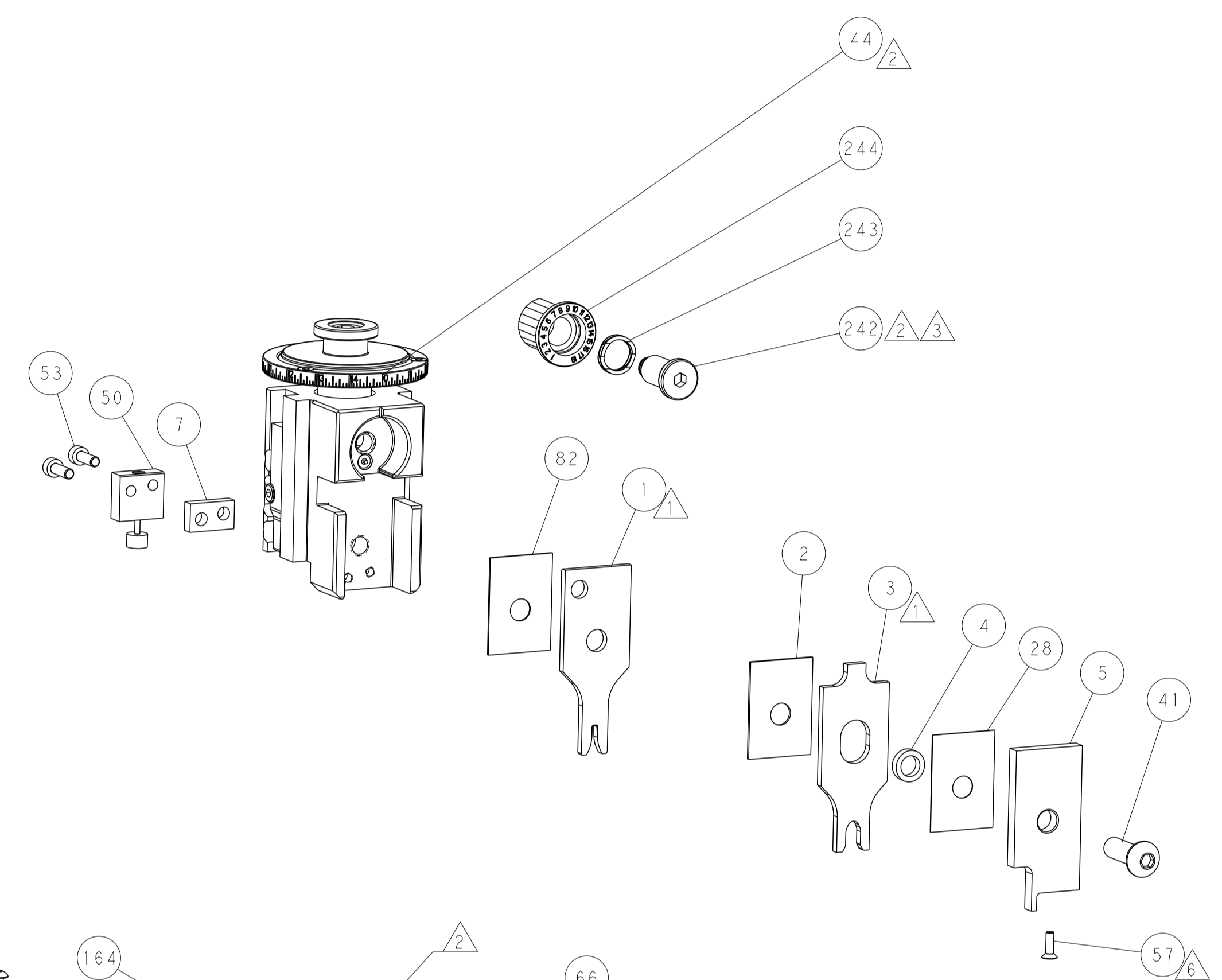
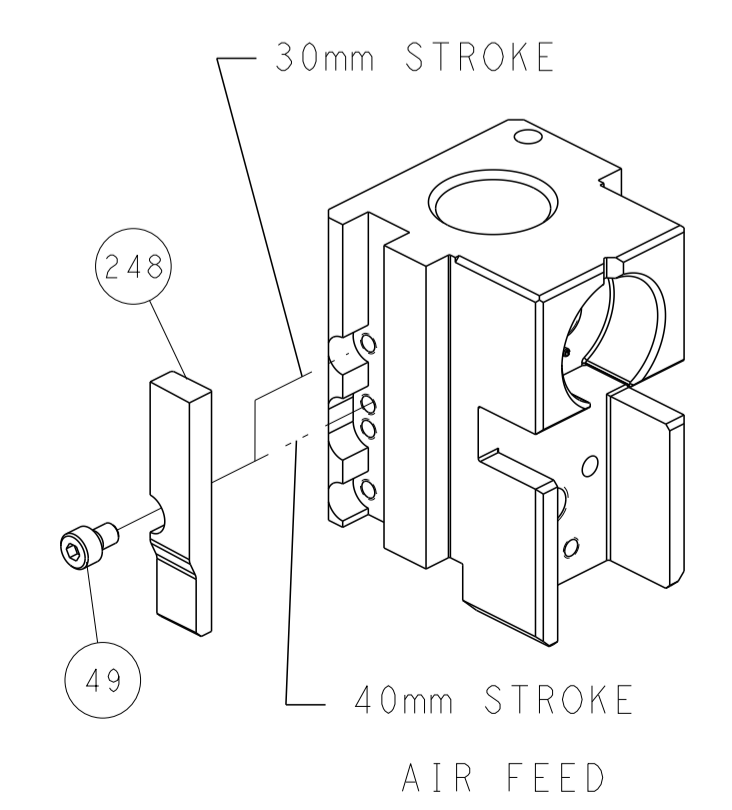

SHEAR DEPRESSOR DETAIL

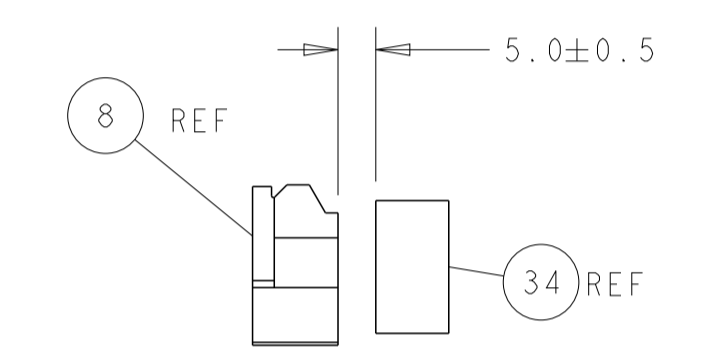

TERMINAL SUPPORT LOCATION

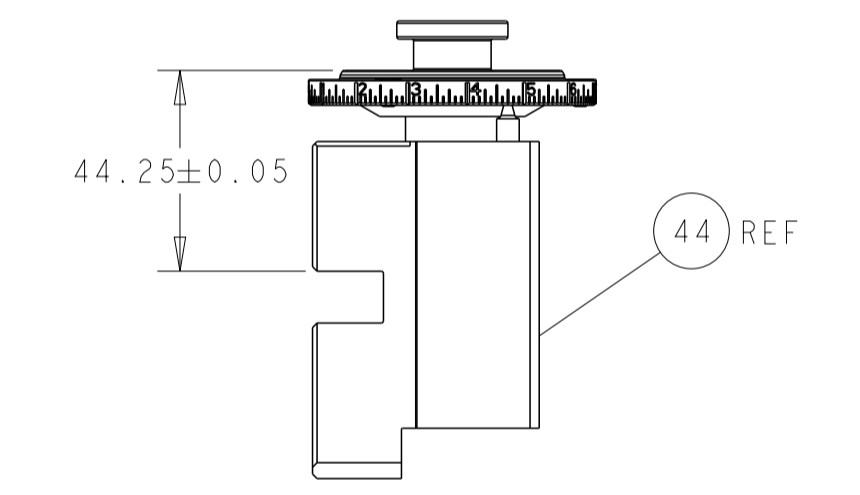

RAM SET-UP

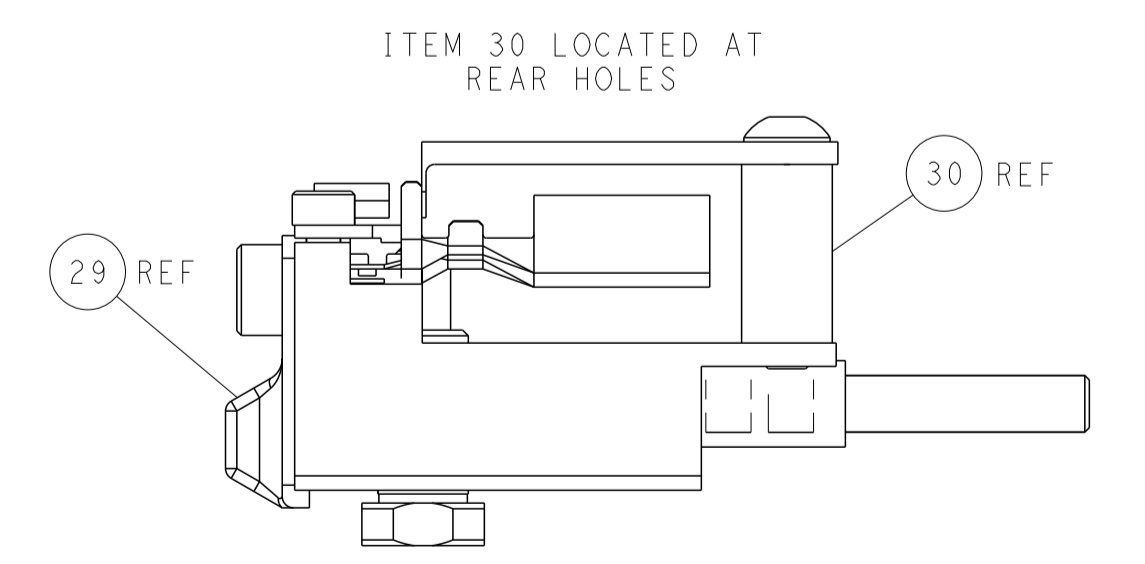
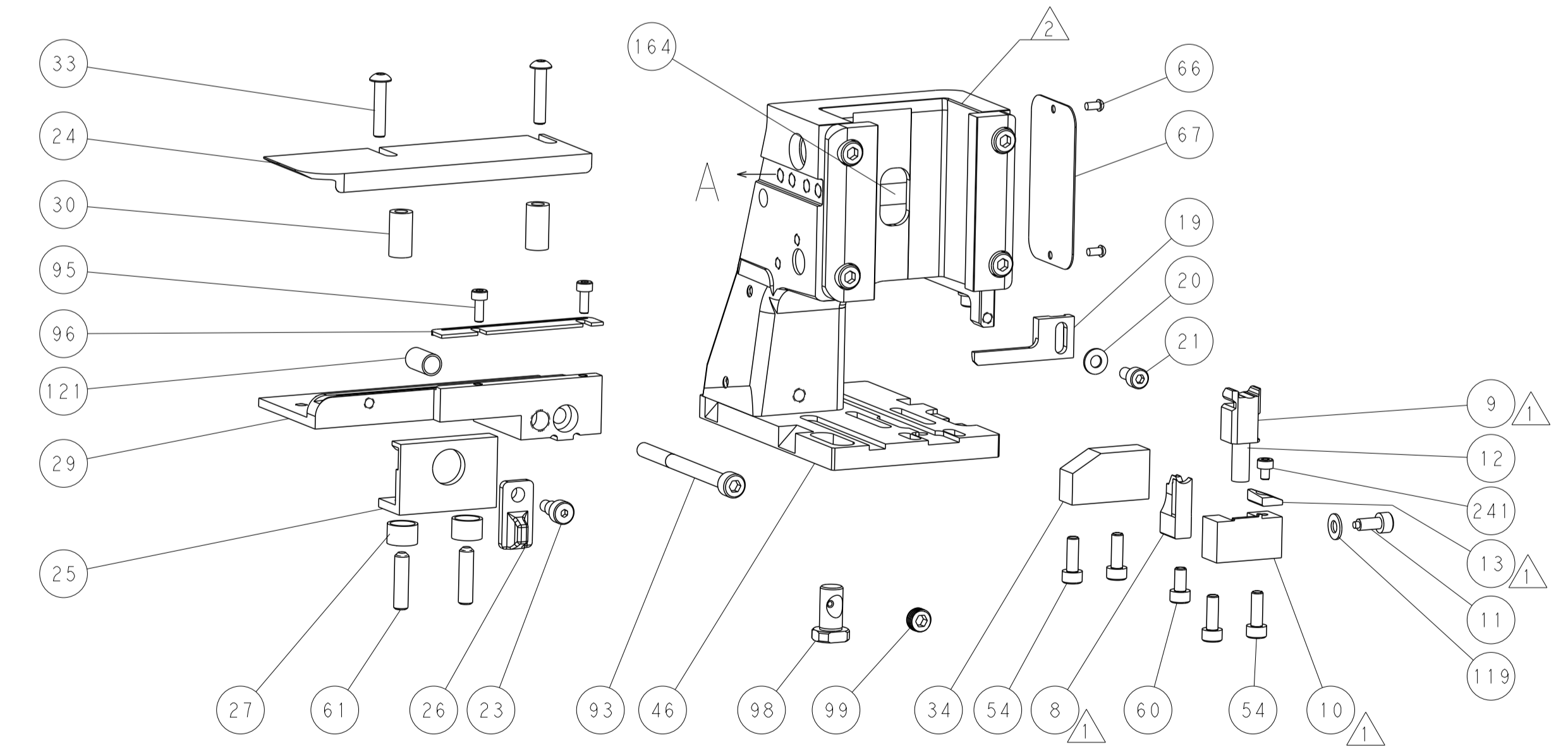

FEED TRACK POSITION GUIDE BY INSULATION BARREL

ATLANTIC VERSION
 Shown on sheets 1 of 4 & 2 of 4
 (Pacific version shown on sheets 3 of 4 & 4 of 4)

DIMENSIONS:		TOLERANCES UNLESS OTHERWISE SPECIFIED:		DWN R. HUANG 05FEB2013		TE Connectivity Harrisburg, PA 17105-3608	
mm	0 PLC ±	1 PLC ±	2 PLC ±	3 PLC ±	4 PLC ±	APVD S. XI 05FEB2013	NAME Ocean Side Feed Applicator
	ANGLES ±	FINISH ±				PRODUCT SPEC	SIZE A1
MATERIAL						APPLICATION SPEC	CAGE CODE 00779
						WEIGHT	DRAWING NO 2151569
						Customer Accessible Production Drawing	RESTRICTED TO
						SCALE 1:2	SHEET 2 OF 4
							REV 1

PART NUMBER	REVISION	DESCRIPTION	FEED TYPE
2-2151569-2	F	FINE CRIMP HEIGHT ADJUST	PNEUMATIC
7-2151569-7	F	CRIMP TOOLING KIT	-

PACIFIC VERSION TERMINATOR
INTERFACE ADAPTER

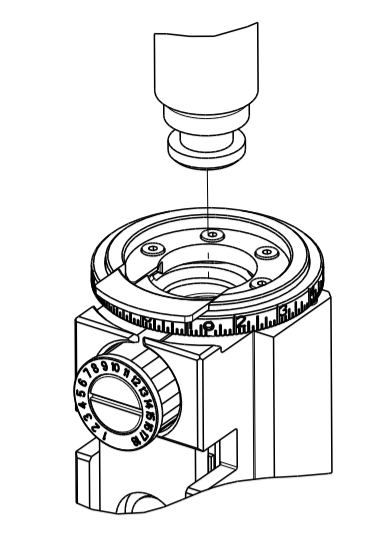

APPLICATOR DATA		
CRIMP	SIZE	TYPE
WIRE	2.03 mm [.080]	F
INSUL	6.35 mm [.250]	O
APPLICATOR INSTRUCTIONS 408-35042		

TERMINAL DATA: TE TERMINAL		TE CRIMP SPECIFICATION	
TERMINAL NAME: TAB 5.8 x 0.8 mm TYP A			
WIRE STRIP LENGTH 4.00-4.60 mm [1.57-.181 IN]		INSULATION DIAMETER RANGE Ø 6.00 MAX [1.236 IN MAX]	
TERMINAL APPLICATION SPECIFICATION	114-18052	-	-
TERMINALS APPLIED			
TE TERMINAL	TE TERMINAL	TE SEAL	SEAL INSULATION DIAMETER RANGE
964310-1	2-964310-2	963243-1	Ø1.4-2.1 mm
		963244-1	Ø2.2-3.0 mm

WIRE SIZE	CRIMP HEIGHT mm [INCH]	CRIMP HEIGHT REFERENCE SETTING
1.00mm2	1.56+/-0.05 [1.061+/-0.002]	5.0
0.75mm2	1.47+/-0.05 [1.058+/-0.002]	6.0
0.50mm2	1.38+/-0.05 [1.054+/-0.002]	7.0

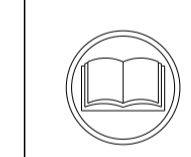

- 1 RECOMMENDED SPARE PARTS.
- 2 REFER TO SUPPLIED INSTRUCTION SHEET FOR CLEANING, LUBRICATION AND STORAGE OF APPLICATOR.
- 3 APPLY PART NUMBER 2-23419-6 LOCTITE TO THREADS OF ITEMS 242.
- 4 CRIMP HEIGHT REFERENCE SETTING WAS THE SETTING USED WHEN THE APPLICATOR WAS QUALIFIED AT THE FACTORY. ADJUSTMENT MAY BE NECESSARY WHEN RUNNING APPLICATOR IN THE FIELD.
- 5 TERMINAL PITCH NOT COMPATIBLE WITH MECHANICAL FEED.
- 6 APPLY TORQ-SEAL IN ALLEN SOCKET TO FILL HOLE AFTER FLAT HD HAS BEEN ADJUSTED TO CORRECT HEIGHT AT QUALIFICATION. APPLY #1-23419-5 LOC-TITE TO THREADS.
- 7. UNLESS SPECIFIED OTHERWISE TORQUE VALUES SHALL BE USED PER DOCUMENT, 101-35000.

ENTRY LEVEL APPLICATOR		ITEM SUBSTITUTION LIST		
PART NUMBER	SAME AS	ITEM	ITEM DESCRIPTION	SUBSTITUTE PART NUMBER
8-2151569-1	2151569-1	1	WIRE CRIMPER	1-1803590-6
8-2151569-2	2151569-2	3	INSULATION CRIMPER	7-1803674-0
9-2151569-1	2-2151569-1	46	BASIC SUB -ASSEMBLY	1803940-9
9-2151569-2	2-2151569-2	141	BASIC SUB -ASSEMBLY	1-1803940-0
			LUBRICATOR	DELETE

***WARNING**
ON INSTALLATION, SET WIRE DISC TO CRIMP HEIGHT REFERENCE SETTING FOR LARGEST WIRE SIZE. CRIMP HEIGHT REFERENCE SETTINGS GREATER THAN THE VALUE SHOWN MAY CAUSE DAMAGE TO THE CRIMP TOOLING, REFER TO THE INSTRUCTION SHEET FOR PROPER SETUP AND ADJUSTMENTS.

PACIFIC VERSION
Shown on sheets 3 of 4 & 4 of 4
(Atlantic version shown on sheets 1 of 4 & 2 of 4)

LOC	DIST	REVISIONS					
A	66	P	LTN	DESCRIPTION	DATE	DWN	APVD
		-		SEE SHEET 1	-	-	-

-	1	2119082-6	CAM, SNAIL, INSULATION ADJUSTMENT	244	
-	1	2079764-1	WASHER, WAVE SPRING, CREST-TO-CREST	243	
-	1	2119083-1	RETAINER, INSULATION DIAL	242	
-	1	7-18023-7	SCR, SKT HD CAP M3 X 4.0	241	
-	1	2844940-1	AIR FEED MODULE	238	
-	REF	994970-2	COUNTER, MAGNETIC	164	
-	1	2119641-2	FEED CAM, AIR FEED	151	
-	1	2168083-8	SCR, SKT HD CAP, RoHS, M4 X 16	144	
-	4	2168083-9	SCR, SKT HD CAP, RoHS, M4 X 20	143	
-	1	1-1803583-0	APPLICATOR BASIC ASSEMBLY, SF	141	
-	1	1803516-1	RAM ASSEMBLY, SF PACIFIC	140	
-	1	1-22281-8	SPRING, COMPRESSION	121	
-	1	1-18028-2	WASHER, FLAT, REG M4	119	
-	1	2844908-1	SCREW, LOCKING	99	
-	1	2844907-1	POST, LOCKING	98	
-	1	2-690438-8	FRONT STRIP GUIDE	96	
-	2	2168083-1	SCR, SKT HD CAP, RoHS, M3 X 8.0	95	
-	1	2168083-6	SCR, SKT HD CAP, RoHS, M5 X 65	93	
-	1	455888-5	SPACER, CRIMPER	82	
-	1	1803607-3	DOCUMENTATION PACKAGE	71	
-	1	2119740-1	TAG, IDENTIFICATION	67	
-	2	2168078-1	SCREW, DRIVE, RH, RoHS, 2 x .188	66	
-	2	2-18032-5	SCR, SET, FLT PNT, M5 X 20.0	61	
-	1	5-18022-5	SCR, HEX HD CAP, M4 X 6.0	59	
-	1	985575-3	SCR, FLT SKT HD CAP M3 X 10.0	57	
-	1	1338685-1	PAWL, FEED	56	
-	2	2168083-3	SCR, SKT HD CAP, RoHS, M4 X 12.0	53	
-	1	1803382-2	HOLD DOWN, SPRING LOADED	50	
-	1	18023-9	SCR, SKT HD CAP M4 X 6.0	49	
-	1	1803602-1	SCR, BHSC, RoHS (M8 X 25)	41	
-	1	1-1752356-1	SUPPORT, TERMINAL	34	
-	2	2079383-5	SCR, BHSC, RoHS (M4 X 20)	33	
-	2	3-2844962-2	SPACER, CYLINDRICAL, STRIP GUIDE	30	
-	1	1-2844938-8	PLATE, STRIP GUIDE	29	
-	1	455888-3	SPACER, CRIMPER	28	
-	2	22283-1	SPRING, COMPRESSION	27	
-	1	356835-1	LEVER, DRAG RELEASE	26	
-	1	240792-1	DRAG, TERMINAL	25	
-	1	1320928-6	STRIP GUIDE	24	
-	1	980371-4	SCR, SKT HD SHLDR 5.0 DIA X 6.0	23	
-	1	2168083-2	SCR, SKT HD CAP, RoHS, M4 X 8.0	21	
-	1	1-18028-2	WASHER, FLAT, REG M4	20	
-	1	2119533-1	STRIPPER, SIDE FEED	19	
-	1	2119806-1	INSERT, SHEAR	13	
-	1	3-22280-3	SPRING, COMPRESSION	12	
-	1	1-356885-4	STOP, SHEAR	11	
-	1	2-2119805-1	SHEAR HOLDER, FRONT	10	
-	1	318707-7	FLOATING SHEAR, FRONT	9	
-	1	9-1633131-9	ANVIL, COMBINATION .080	8	
-	1	240641-3	SPACER	7	
-	-	-	-	6	
-	1	2119781-6	DEPRESSOR, SHEAR	5	
-	1	2-238011-1	BLOCK, CRIMPER SPACER	4	
-	1	7-1633996-0	CRIMPER, INSULATION SPECIAL	3	
-	1	455888-8	SPACER, CRIMPER	2	
-	1	1-456405-6	CRIMPER, WIRE PREMIUM	1	
-	77	-22	PART NO	DESCRIPTION	ITEM NO

<small>THIS IS A PRELIMINARY DRAWING. IT IS SUBJECT TO CHANGE WITHOUT NOTICE AND WITHOUT LIABILITY. THE USER SHALL BE RESPONSIBLE FOR VERIFYING THE DIMENSIONS AND TOLERANCES OF THE PARTS TO BE USED IN THE ASSEMBLY.</small>		DWN H. HUANG CHK S. XI APVD S. XI DATE 05FEB2013	TE Connectivity Harrisburg, PA 17105-3608
DIMENSIONS: mm		TOLERANCES UNLESS OTHERWISE SPECIFIED: 0 PLC ± 1 PLC ± 2 PLC ± 3 PLC ± 4 PLC ± ANGLES ± FINISH ±	NAME Ocean Side Feed Applicator
MATERIAL:		WEIGHT:	SIZE: A1 CAGE CODE: 00779 DRAWING NO: ©=2151569 RESTRICTED TO:
Customer Accessible Production Drawing		SCALE: 1:2	SHEET 3 OF 4 REV F1

LOC	DIST	REVISIONS					
A	66	P	LTN	DESCRIPTION	DATE	DWN	APVD
		-		SEE SHEET 1	-	-	-

FEED TYPE

PNEUMATIC

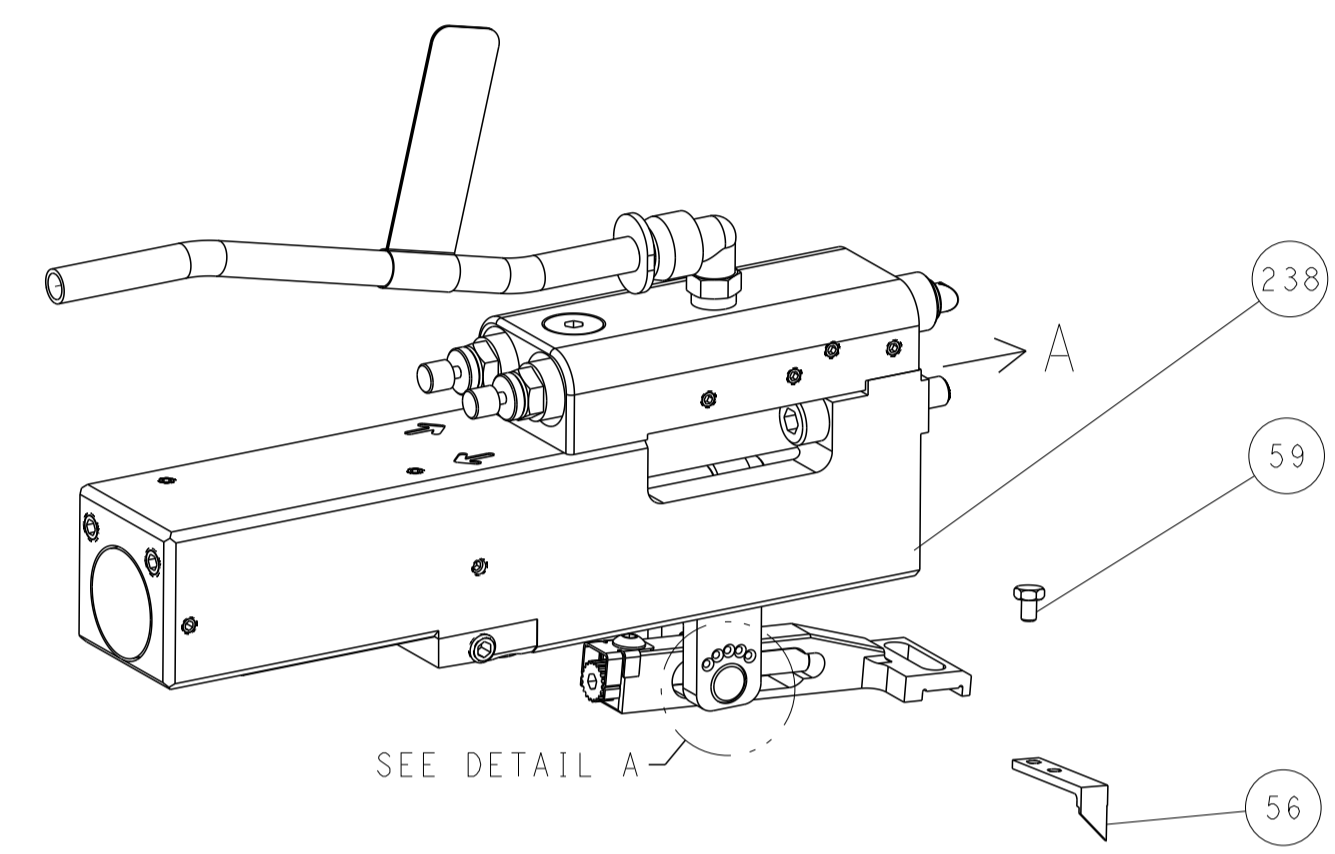

FEED SPRING SETTING POSITION (SHOWN FROM REAR SIDE)

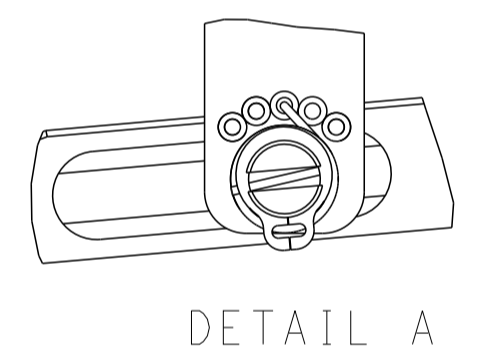

DETAIL A

30mm STROKE

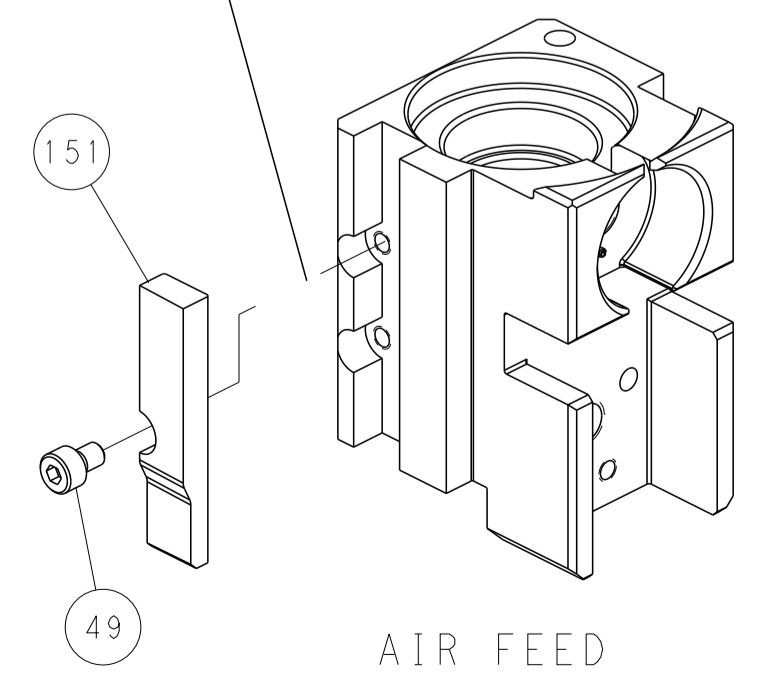

AIR FEED

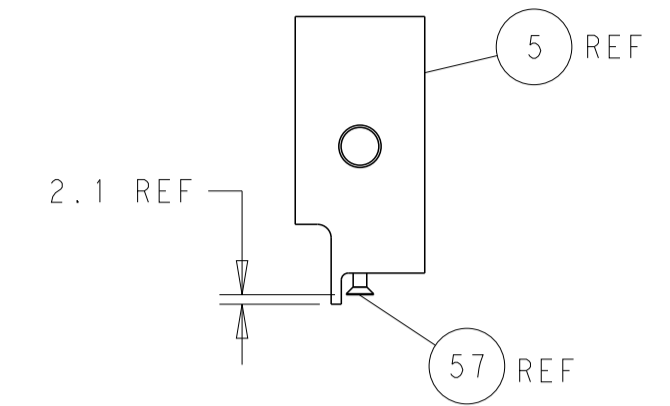
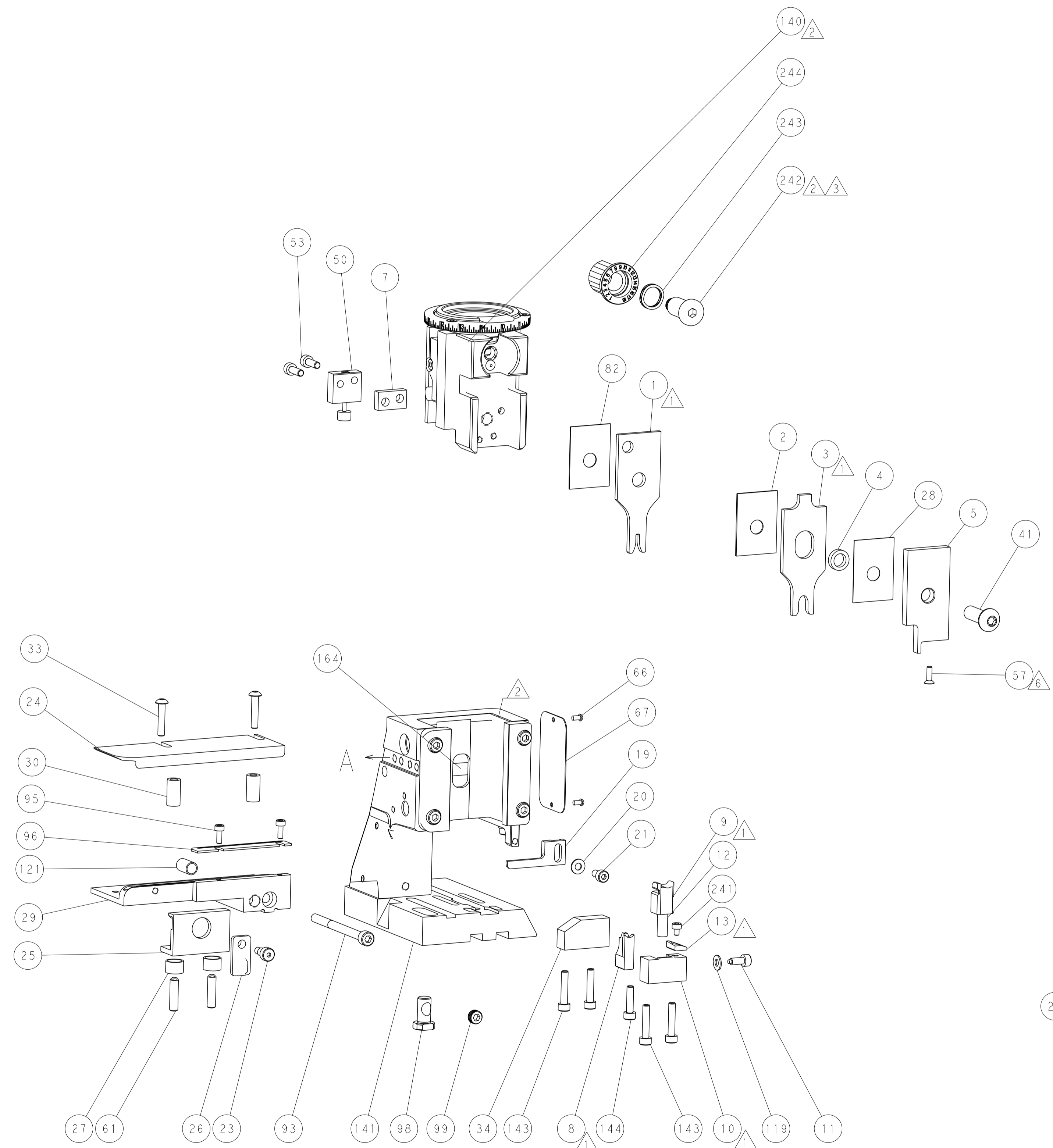

SHEAR DEPRESSOR DETAIL

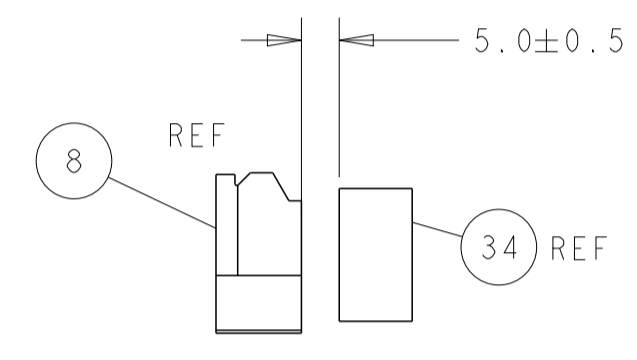

TERMINAL SUPPORT LOCATION

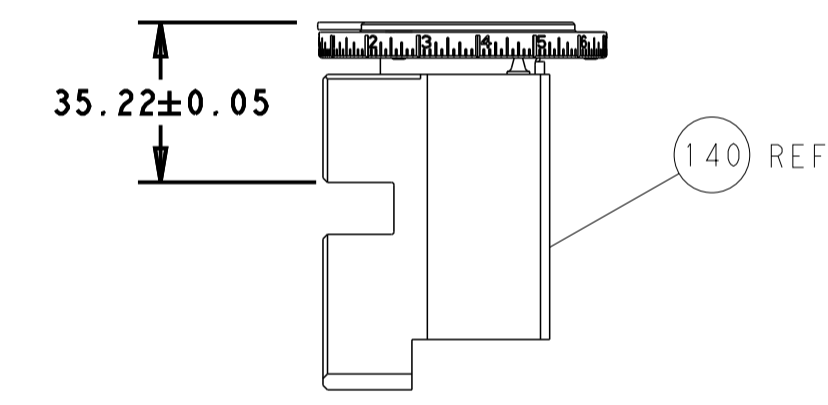

RAM SET-UP

ITEM 30 LOCATED AT REAR HOLES

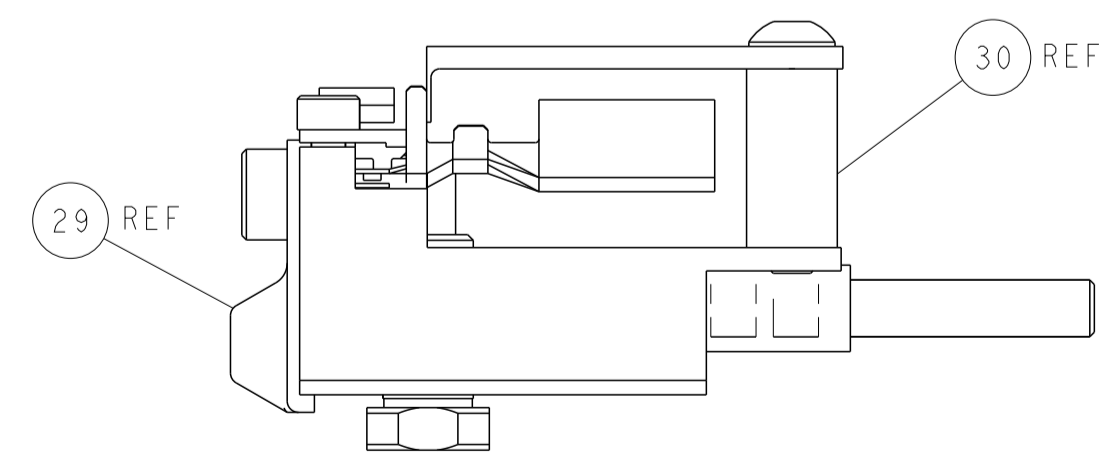

FEED TRACK POSITION GUIDE BY INSULATION BARREL

PACIFIC VERSION
 Shown on sheets 3 of 4 & 4 of 4
 (Atlantic version shown on sheets 1 of 4 & 2 of 4)

<small>THIS DRAWING IS UNPUBLISHED. RELEASED FOR PUBLICATION. IT IS THE POLICY OF TYCO ELECTRONICS CORPORATION TO CONTINUE TO IMPROVE ITS PRODUCTS. THEREFORE, THIS DRAWING IS SUBJECT TO CHANGE WITHOUT NOTICE. THE USER ASSUMES ALL RESPONSIBILITY FOR THE LATEST REVISION.</small>		DWN: H. HUANG 05FEB2013 CHK: S. XI 05FEB2013 APVD: S. XI 05FEB2013	TE Connectivity Harrisburg, PA 17105-3608
DIMENSIONS: mm TOLERANCES UNLESS OTHERWISE SPECIFIED: 0 PLC ± 1 PLC ± 2 PLC ± 3 PLC ± 4 PLC ± ANGLES ± MATERIAL: - FINISH: -		NAME: Ocean Side Feed Applicator PRODUCT SPEC: - APPLICATION SPEC: - SIZE: A1 CAGE CODE: 00779 DRAWING NO: 2151569 WEIGHT: - SCALE: 1:2 SHEET: 4 OF 4 REV: 1	RESTRICTED TO: -