

REV.	DESCRIPTION	DRAWN	DATE
A	NEW	JASON	2018-4-24

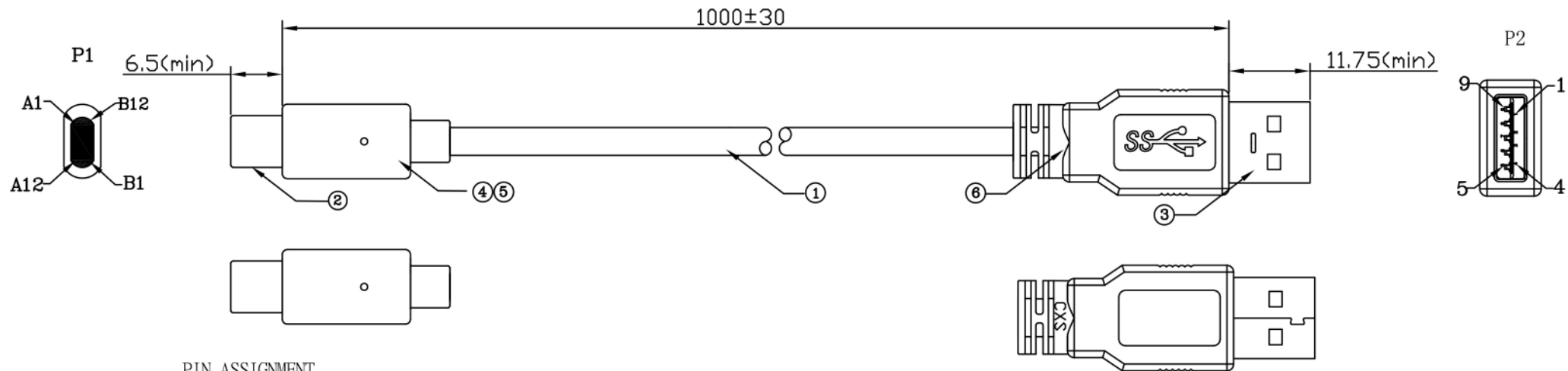

PIN ASSIGNMENT

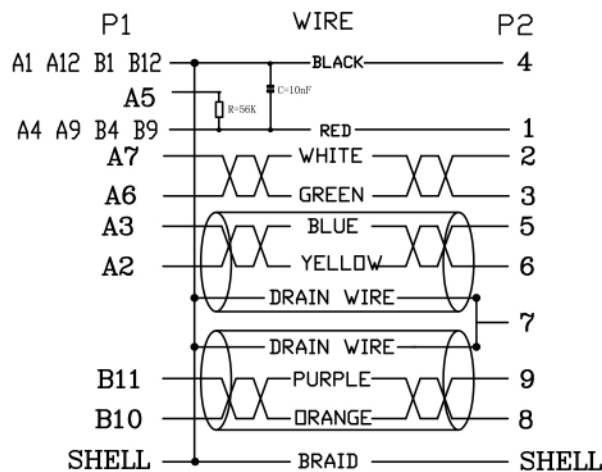

- NOTE:
- 100% open / short test.
 - Insulation resistance: Min 5M ohm with DC 300V.
 - Conductor resistance: Max 5ohm
 - Environmental compliance: Rohs&Reach.

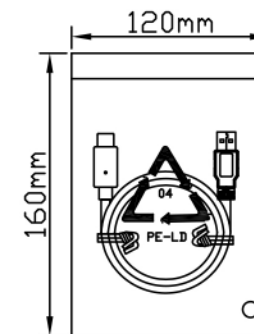

6	OVER MOLD	PVC 50P BLACK.
5	OVER MOLD	PVC 35P BLACK.
4	INSER MOLD	LD-PE
3	CONN#2	USB 3.1 A(O) SOLDER TYPE PIN:PLATED GOLD 1U", INSULATION:BLUE, SHELL:NI-PLATED
2	CONN#1	USB 3.1 C TYPE, PIN:PLATED GOLD, TENSILE TYPE IRON SHELL,PULL-UP RESISTORS:56K.
1	CABLE	USB3.1 30AWG*2P+30AWG*1P+24WG*2C+AB, OD=4.5, BLACK PVC,
ITEM	NAME	DESCRIPTION

GENERAL TOLERANG	ANGLE TOLERANG	DATE.	2018-4-24	Oyen Digital LLC	
X. ±0.5 X.X±0.25	X°. ±2.0° X.X°±1.0°	DRAW.	JASON	DESCRIPTION	USB 3.1 C TYPE TO USB 3.1 A TYPE
UNIT: MM	SCALE:N/A	CHACK.		PART NO	18-26UC11
A4	SHEET:1of1	APPRO.		FILE NAME	IQ1708181
					REV:A