

LOC		DIST		REVISIONS			
P	LTR	DESCRIPTION	DATE	DWN	APVD		
E1	REVISED	ECR-06-002095	20,JAN'08	YH	JK		
E2	REVISED	ECR-06-002993	07,FEB'08	YH	JK		
E3	REVISED	ECR-06-004324	13,SEP'08	BS	JK		

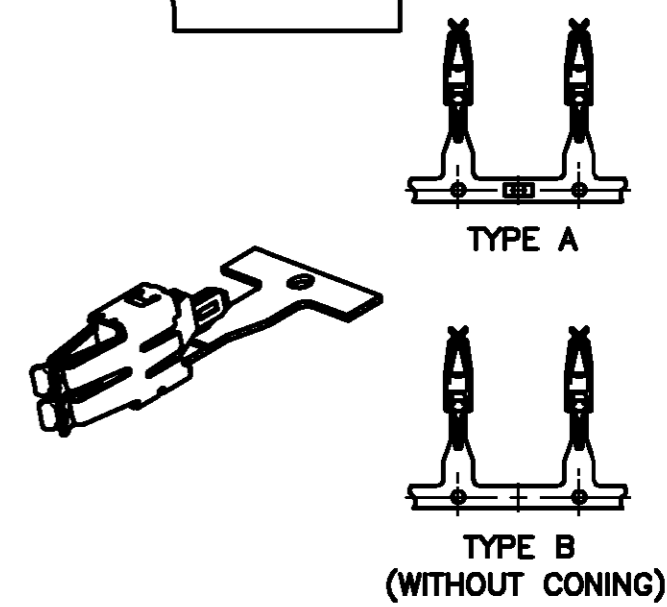

	TOP OF REEL	PART NUMBER	REEL TYPE	REMARK
'Y'	2-	368028 -1	TYPE B	1POST
'X'	1-	368028 -2	TYPE A	
'Y'	1-	368028 -1		
'Z'		368028 -1		

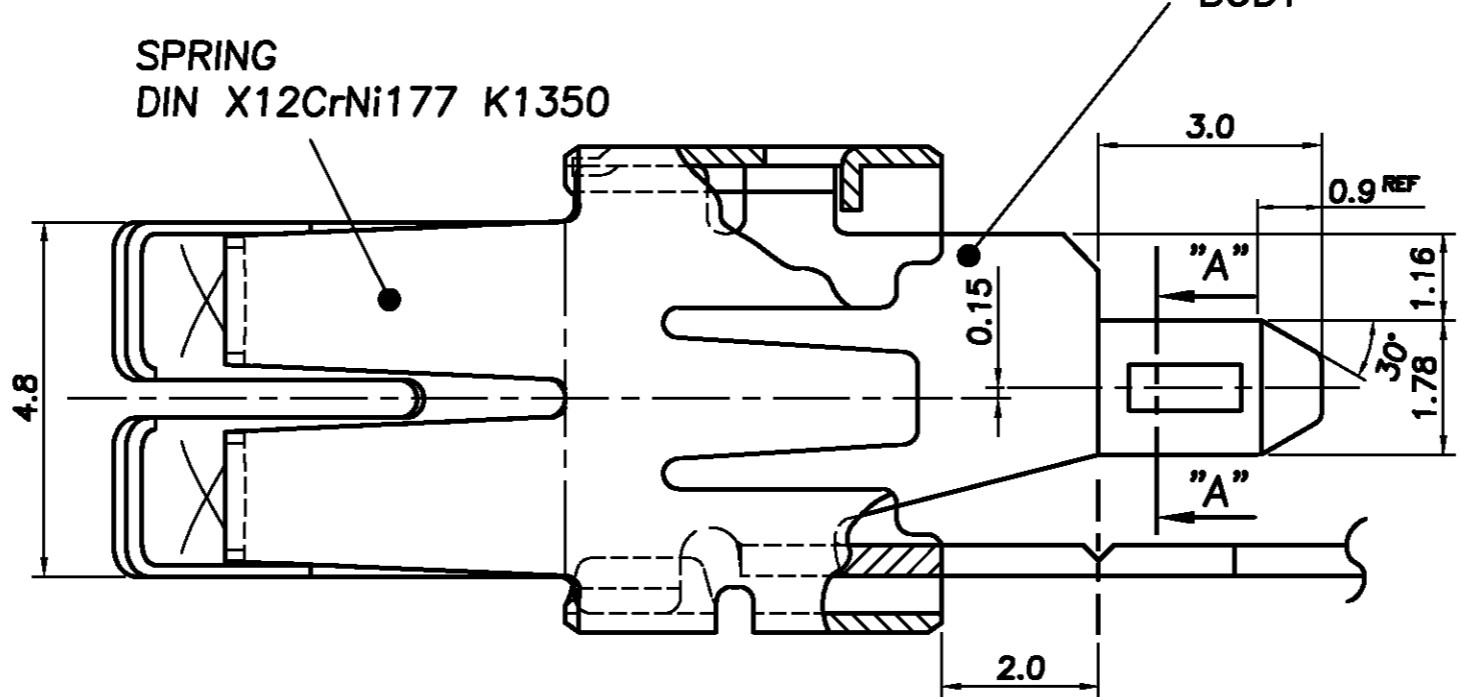
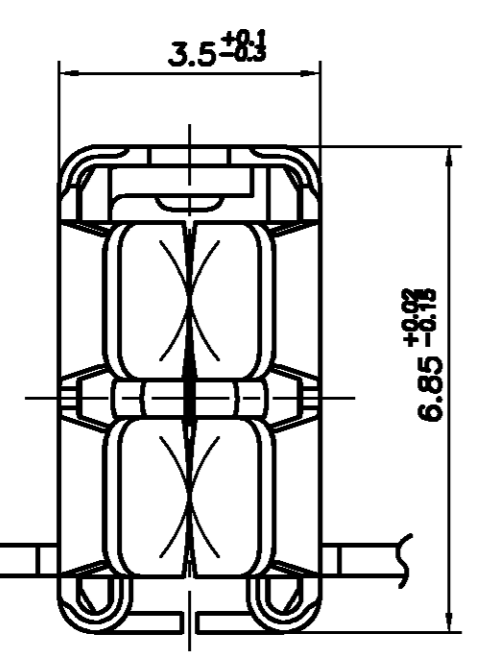
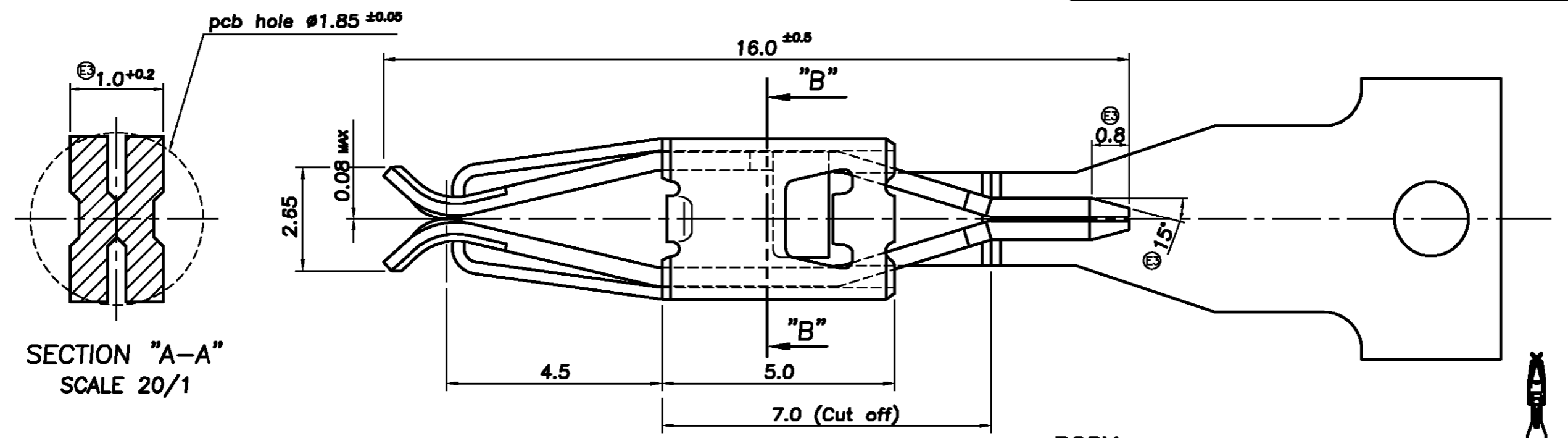
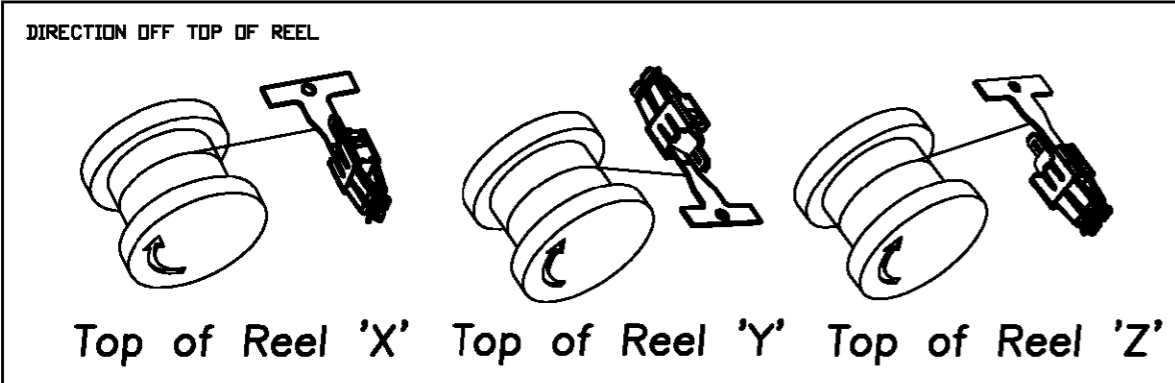

THIS DRAWING IS A CONTROLLED DOCUMENT FOR TYCO ELECTRONICS CORPORATION. IT IS SUBJECT TO CHANGE AND THE CONTROLLING ENGINEERING ORGANIZATION SHOULD BE CONTACTED FOR THE LATEST REVISION.

DIMENSIONS: MM	TOLERANCES UNLESS OTHERWISE SPECIFIED: 0 <XX<10 ± 0.2 10 <XX<30 ± 0.25 30 <XX<100 ± 0.3 ANGLES ± 3°	DWN BS.YOO CHK YM.CHOI APVD JK SONG PRODUCT SPEC 108-61041 APPLICATION SPEC	<b>tyco</b> AMP KOREA, kyungsan, korea <b>Electronics</b> NAME <b>STANDARD POWER TIMER CONTACT FOR P.C.B - W/O LATCH</b>
3rd ANGLE PROJECTION	MATERIAL: CuNiSi Alloy 0.4Thk.	FINISH: PRE-TINNED	
WEIGHT: NET. 1.02gf CUSTOMER DRAWING		SIZE: A3 CAGE CODE: 00779 DRAWING NO: 368028 RESTRICTED TO:	SCALE: 10/1 SHEET: 1 OF 2 REV: E3

LOC		DIST		REVISIONS			
P	LTR	DESCRIPTION	DATE	DWN	APVD		
SEE SHEET 1 OF 2							

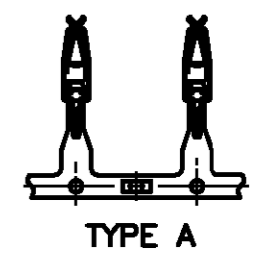
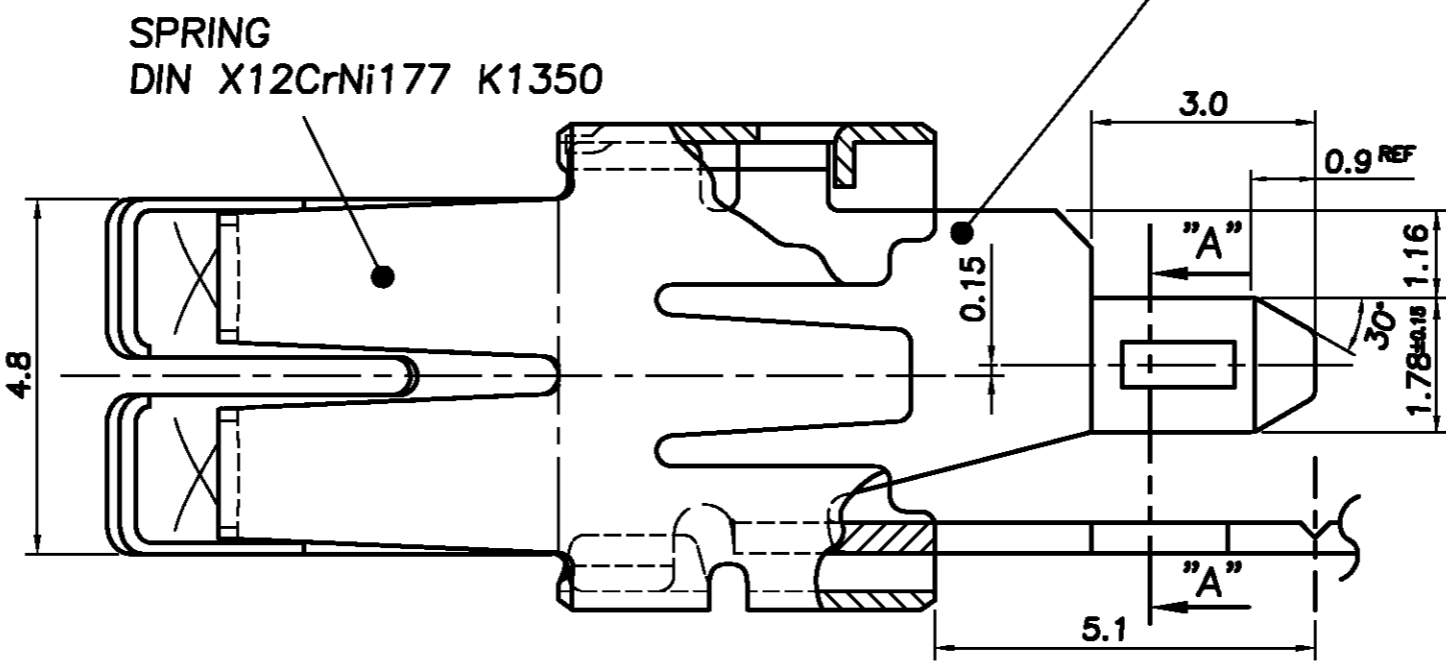
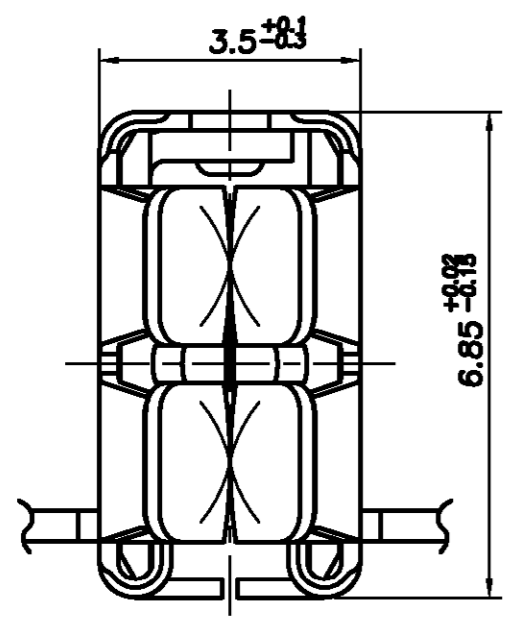
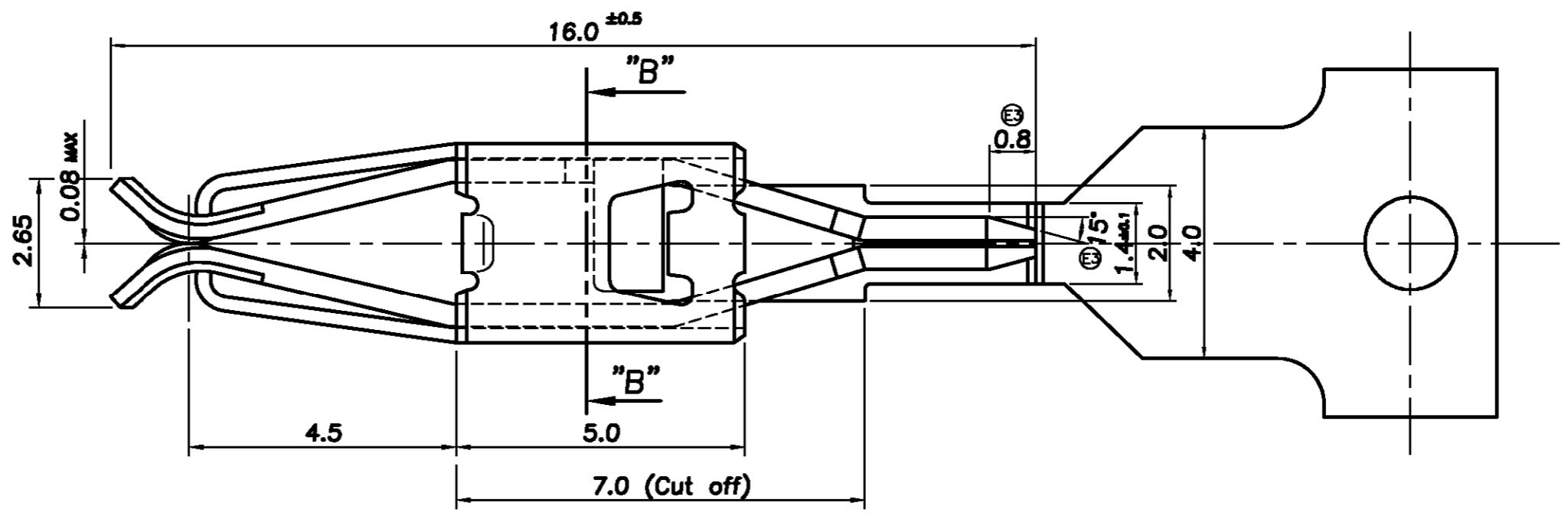
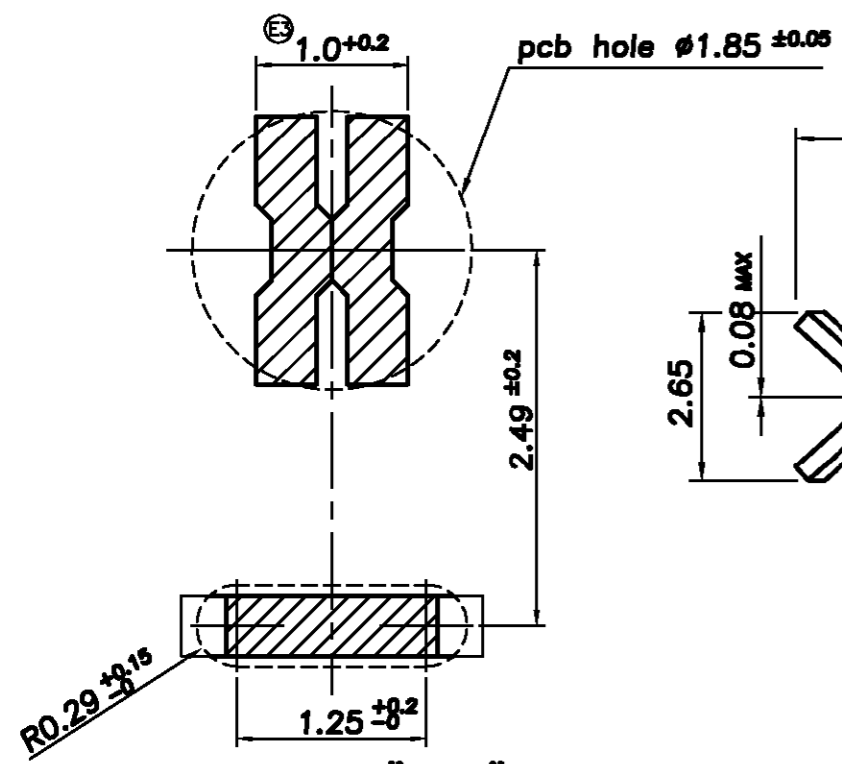

'Y'	1- 368028 -3	TYPE A	2 POST
⊕ 'X'	0- 368028 -3		
TOP OF REEL	PART NUMBER	REEL TYPE	REMARK

DIRECTION OFF TOP OF REEL

SEE SHEET 1 OF 2

THIS DRAWING IS A CONTROLLED DOCUMENT FOR TYCO ELECTRONICS CORPORATION. IT IS SUBJECT TO CHANGE AND THE CONTROLLING ENGINEERING ORGANIZATION SHOULD BE CONTACTED FOR THE LATEST REVISION.

DIMENSIONS: MM	TOLERANCES UNLESS OTHERWISE SPECIFIED:
	0 <XX<10 ± 0.2
	10 <XX<30 ± 0.25
	30 <XX<100 ± 0.3
	ANGLES ± 3°
MATERIAL	FINISH
CuNiSi Alloy 0.4Thk.	PRE-TINNED

DWN	
CHK	
APVD	
PRODUCT SPEC	108-61041
APPLICATION SPEC	
WEIGHT	NET. 1.06gf

<b>tyco</b> Electronics		AMP KOREA, kyungsan, korea	
NAME: STANDARD POWER TIMER CONTACT FOR P.C.B - W/O LATCH			
SIZE	CAGE CODE	DRAWING NO	RESTRICTED TO
A3	00779	368028	
CUSTOMER DRAWING		SCALE 10/1	SHEET 2 OF 2 REV E3

