

**Audio PICtail™ Plus
Daughter Board
User's Guide**

Note the following details of the code protection feature on Microchip devices:

- Microchip products meet the specification contained in their particular Microchip Data Sheet.
- Microchip believes that its family of products is one of the most secure families of its kind on the market today, when used in the intended manner and under normal conditions.
- There are dishonest and possibly illegal methods used to breach the code protection feature. All of these methods, to our knowledge, require using the Microchip products in a manner outside the operating specifications contained in Microchip's Data Sheets. Most likely, the person doing so is engaged in theft of intellectual property.
- Microchip is willing to work with the customer who is concerned about the integrity of their code.
- Neither Microchip nor any other semiconductor manufacturer can guarantee the security of their code. Code protection does not mean that we are guaranteeing the product as "unbreakable."

Code protection is constantly evolving. We at Microchip are committed to continuously improving the code protection features of our products. Attempts to break Microchip's code protection feature may be a violation of the Digital Millennium Copyright Act. If such acts allow unauthorized access to your software or other copyrighted work, you may have a right to sue for relief under that Act.

Information contained in this publication regarding device applications and the like is provided only for your convenience and may be superseded by updates. It is your responsibility to ensure that your application meets with your specifications. MICROCHIP MAKES NO REPRESENTATIONS OR WARRANTIES OF ANY KIND WHETHER EXPRESS OR IMPLIED, WRITTEN OR ORAL, STATUTORY OR OTHERWISE, RELATED TO THE INFORMATION, INCLUDING BUT NOT LIMITED TO ITS CONDITION, QUALITY, PERFORMANCE, MERCHANTABILITY OR FITNESS FOR PURPOSE. Microchip disclaims all liability arising from this information and its use. Use of Microchip devices in life support and/or safety applications is entirely at the buyer's risk, and the buyer agrees to defend, indemnify and hold harmless Microchip from any and all damages, claims, suits, or expenses resulting from such use. No licenses are conveyed, implicitly or otherwise, under any Microchip intellectual property rights.

Trademarks

The Microchip name and logo, the Microchip logo, Accuron, dsPIC, KEELOQ, KEELOQ logo, microID, MPLAB, PIC, PICmicro, PICSTART, PRO MATE, rPIC and SmartShunt are registered trademarks of Microchip Technology Incorporated in the U.S.A. and other countries.

Amplab, FilterLab, Linear Active Thermistor, Migratable Memory, MXDEV, MXLAB, SEEVAL, SmartSensor and The Embedded Control Solutions Company are registered trademarks of Microchip Technology Incorporated in the U.S.A.

Analog-for-the-Digital Age, Application Maestro, CodeGuard, dsPICDEM, dsPICDEM.net, dsPICworks, dsSPEAK, ECAN, ECONOMONITOR, FanSense, FlexROM, fuzzyLAB, In-Circuit Serial Programming, ICSP, ICEPIC, Mindi, MiWi, MPASM, MPLAB Certified logo, MPLIB, MPLINK, PICkit, PICDEM, PICDEM.net, PICLAB, PICtail, PowerCal, PowerInfo, PowerMate, PowerTool, REAL ICE, rLAB, Select Mode, Smart Serial, SmartTel, Total Endurance, UNI/O, WiperLock and ZENA are trademarks of Microchip Technology Incorporated in the U.S.A. and other countries.

SQTP is a service mark of Microchip Technology Incorporated in the U.S.A.

All other trademarks mentioned herein are property of their respective companies.

© 2007, Microchip Technology Incorporated, Printed in the U.S.A., All Rights Reserved.

 Printed on recycled paper.

QUALITY MANAGEMENT SYSTEM
CERTIFIED BY DNV
== ISO/TS 16949:2002 ==

Microchip received ISO/TS-16949:2002 certification for its worldwide headquarters, design and wafer fabrication facilities in Chandler and Tempe, Arizona; Gresham, Oregon and design centers in California and India. The Company's quality system processes and procedures are for its PIC® MCUs and dsPIC® DSCs, KEELOQ® code hopping devices, Serial EEPROMs, microperipherals, nonvolatile memory and analog products. In addition, Microchip's quality system for the design and manufacture of development systems is ISO 9001:2000 certified.



AUDIO PICtail™ PLUS DAUGHTER BOARD USER'S GUIDE

Table of Contents

Preface	1
Chapter 1. Introduction	
1.1 Overview	7
1.2 Board Setup	8
1.3 Reference Documents	9
Chapter 2. Hardware	
2.1 Functional Overview	11
2.2 Hardware Components	13
Chapter 3. PWM Speech Loopback Demo	
3.1 Speech Loopback Demo	19
3.2 Running the Demo	22
Appendix A. Drawings and Schematics	
A.1 Audio PICtail Plus Daughter Board Layout	23
A.2 Schematic Diagrams	23
Index	29
Worldwide Sales and Service	30

Audio PICtail™ Plus Daughter Board User's Guide

NOTES:



AUDIO PICtail™ PLUS DAUGHTER BOARD USER'S GUIDE

Preface

NOTICE TO CUSTOMERS

All documentation becomes dated, and this manual is no exception. Microchip tools and documentation are constantly evolving to meet customer needs, so some actual dialogs and/or tool descriptions may differ from those in this document. Please refer to our web site (www.microchip.com) to obtain the latest documentation available.

Documents are identified with a “DS” number. This number is located on the bottom of each page, in front of the page number. The numbering convention for the DS number is “DSXXXXA”, where “XXXX” is the document number and “A” is the revision level of the document.

For the most up-to-date information on development tools, see the MPLAB® IDE online help. Select the Help menu, and then Topics to open a list of available online help files.

INTRODUCTION

This chapter contains general information that will be useful to know before you use the Audio PICtail™ Plus Daughter Board. Items discussed in this chapter include:

- Document Layout
- Conventions Used in this Guide
- Warranty Registration
- Recommended Reading
- The Microchip Web Site
- Development Systems Customer Change Notification Service
- Customer Support
- Document Revision History

DOCUMENT LAYOUT

This document describes how to use the Audio PICtail Plus Daughter Board as a development tool to emulate and debug firmware on a target board. The manual layout is as follows:

- **Chapter 1. Introduction** – This chapter introduces the Audio PICtail Plus Daughter Board and provides an overview of its features.
- **Chapter 2. Hardware** – This chapter provides a functional overview of the Audio PICtail Plus Daughter Board and identifies the major hardware components.
- **Chapter 3. PWM Speech Loopback Demo** – This chapter describes a simple loopback program that demonstrates how to use the Audio PICtail Plus Daughter Board for speech capture and playback without the use of a codec.
- **Appendix A. Drawings and Schematics** – This appendix provides detailed technical drawings and schematic diagrams of the Audio PICtail Plus Daughter Board.

Audio PICtail™ Plus Daughter Board User's Guide

CONVENTIONS USED IN THIS GUIDE

This manual uses the following documentation conventions:

DOCUMENTATION CONVENTIONS

Description	Represents	Examples
Arial font:		
Italic characters	Referenced books	<i>MPLAB® IDE User's Guide</i>
	Emphasized text	...is the <i>only</i> compiler...
Initial caps	A window	the Output window
	A dialog	the Settings dialog
	A menu selection	select Enable Programmer
Quotes	A field name in a window or dialog	"Save project before build"
Underlined, italic text with right angle bracket	A menu path	<u><i>File>Save</i></u>
Bold characters	A dialog button	Click OK
	A tab	Click the Power tab
N'Rnnnn	A number in verilog format, where N is the total number of digits, R is the radix and n is a digit.	4'b0010, 2'hF1
Text in angle brackets < >	A key on the keyboard	Press <Enter>, <F1>
Courier New font:		
Plain Courier New	Sample source code	#define START
	Filenames	autoexec.bat
	File paths	c:\mcc18\h
	Keywords	_asm, _endasm, static
	Command-line options	-Opa+, -Opa-
	Bit values	0, 1
	Constants	0xFF, 'A'
Italic Courier New	A variable argument	<i>file.o</i> , where <i>file</i> can be any valid filename
Square brackets []	Optional arguments	mcc18 [options] <i>file</i> [options]
Curly brackets and pipe character: { }	Choice of mutually exclusive arguments; an OR selection	errorlevel {0 1}
Ellipses...	Replaces repeated text	var_name [, var_name...]
	Represents code supplied by user	void main (void) { ... }

WARRANTY REGISTRATION

Please complete the enclosed Warranty Registration Card and mail it promptly. Sending in the Warranty Registration Card entitles you to receive new product updates. Interim software releases are available at the Microchip web site.

RECOMMENDED READING

This user's guide describes how to use Audio PICtail Plus Daughter Board. Other useful documents are listed below. The following Microchip documents are available and recommended as supplemental reference resources.

Readme Files

For the latest information on using other tools, read the tool-specific Readme files in the Readmes subdirectory of the MPLAB[®] IDE installation directory. The Readme files contain update information and known issues that may not be included in this user's guide.

PIC24H Family Overview (DS70166)

This document provides an overview of the functionality of the new PIC24H product family. It helps to determine how the PIC24H high-performance, 16-bit microcontrollers fit a specific product application.

PIC24H Family Reference Manual (www.microchip.com)

Refer to this document for detailed information on PIC24H device operation. This reference manual explains the operation of the PIC24H family architecture and peripheral modules, but does not cover the specifics of each device. Refer also to the appropriate device data sheet for device-specific information and specifications.

dsPIC33F Family Reference Manual (www.microchip.com)

Refer to this document for detailed information on dsPIC33F device operation. This reference manual explains the operation of the dsPIC33F Digital Signal Controller (DSC) family architecture and peripheral modules, but does not cover the specifics of each device. Refer also to the appropriate device data sheet for device-specific information and specifications.

dsPIC33F Family Datasheet (DS70165)

This document provides an overview of the functionality of the dsPIC33F DSC product family. It includes device-specific information such as pinout diagrams, register maps, electrical specifications and packaging, in addition to an overview of the CPU and peripheral features.

dsPIC30F/33F Programmer's Reference Manual (DS70157)

This manual is a software developer's reference for the dsPIC30F and dsPIC33F 16-bit DSC devices. This manual describes the instruction set in detail and also provides general information to assist in developing software for the dsPIC30F/33F DSC family.

Audio PICtail™ Plus Daughter Board User's Guide

MPLAB® ASM30, MPLAB® LINK30 and Utilities User's Guide (DS51317)

This document helps you use Microchip Technology's language tools for dsPIC33F DSC and PIC24H MCU devices based on GNU technology. The language tools discussed are:

- MPLAB ASM30 Assembler
- MPLAB LINK30 Linker
- MPLAB LIB30 Archiver/Librarian
- Other Utilities

MPLAB® C30 C Compiler User's Guide and Libraries (DS51284)

This document helps you use Microchip's MPLAB C30 C compiler to develop your application. MPLAB C30 is a GNU-based language tool, based on source code from the Free Software Foundation (FSF). For more information about FSF, see

www.fsf.org.

MPLAB® REAL ICE™ In-Circuit Emulator User's Guide (DS51616)

This document describes how to use the MPLAB REAL ICE in-circuit emulator as a development tool to emulate and debug firmware on a target board, as well as how to program devices.

THE MICROCHIP WEB SITE

Microchip provides online support via our web site at www.microchip.com. This web site is used as a means to make files and information easily available to customers. Accessible by using your favorite Internet browser, the web site contains the following information:

- **Product Support** – Data sheets and errata, application notes and sample programs, design resources, user's guides and hardware support documents, latest software releases and archived software
- **General Technical Support** – Frequently Asked Questions (FAQs), technical support requests, online discussion groups, Microchip consultant program member listing
- **Business of Microchip** – Product selector and ordering guides, latest Microchip press releases, listing of seminars and events, listings of Microchip sales offices, distributors and factory representatives

DEVELOPMENT SYSTEMS CUSTOMER CHANGE NOTIFICATION SERVICE

Microchip's customer notification service helps keep customers current on Microchip products. Subscribers will receive e-mail notification whenever there are changes, updates, revisions or errata related to a specified product family or development tool of interest.

To register, access the Microchip web site at www.microchip.com, click on Customer Change Notification and follow the registration instructions.

The Development Systems product group categories are:

- **Compilers** – The latest information on Microchip C compilers and other language tools. These include the MPLAB C18 and MPLAB C30 C compilers; MPASM™ and MPLAB ASM30 assemblers; MPLINK™ and MPLAB LINK30 object linkers; and MPLIB™ and MPLAB LIB30 object librarians.
- **Emulators** – The latest information on Microchip in-circuit emulators. This includes the MPLAB ICE 2000 and MPLAB ICE 4000.
- **In-Circuit Debuggers** – The latest information on the Microchip in-circuit debugger, MPLAB ICD 2.
- **MPLAB® IDE** – The latest information on Microchip MPLAB IDE, the Windows® Integrated Development Environment for development systems tools. This list is focused on the MPLAB IDE, MPLAB SIM simulator, MPLAB IDE Project Manager and general editing and debugging features.
- **Programmers** – The latest information on Microchip programmers. These include the MPLAB PM3 and PRO MATE® II device programmers and the PICSTART® Plus and PICKit™ 1 development programmers.

CUSTOMER SUPPORT

Users of Microchip products can receive assistance through several channels:

- Distributor or Representative
- Local Sales Office
- Field Application Engineer (FAE)
- Technical Support

Customers should contact their distributor, representative or field application engineer (FAE) for support. Local sales offices are also available to help customers. A listing of sales offices and locations is included in the back of this document.

Technical support is available through the web site at: <http://support.microchip.com>

Audio PICtail™ Plus Daughter Board User's Guide

DOCUMENT REVISION HISTORY

Revision A (October 2007)

- Initial Release of this Document.



AUDIO PICtail™ PLUS DAUGHTER BOARD USER'S GUIDE

Chapter 1. Introduction

Thank you for purchasing Microchip Technology's Audio PICtail Plus Daughter Board. This board provides a low-cost interface for speech sampling and playback. The Audio PICtail Plus Daughter Board is used with the Explorer 16 Development Board to demonstrate an effective software technique for processing acceptable voice quality audio without the use of a codec device.

This chapter introduces the Audio PICtail Plus Daughter Board and provides an overview of its features. Topics covered include:

- Overview
- Board Setup
- Reference Documents

1.1 OVERVIEW

The Audio PICtail Plus Daughter Board fits into the expansion slot on the Explorer 16 board and interfaces between an external audio device and the dsPIC33F or PIC24H device on the Explorer 16 board. Audio input signals are routed to the Analog-to-Digital Converter (ADC) module on the dsPIC33F or PIC24H device for software processing. Output signals can be generated by the dsPIC33F or PIC24H on the Output Compare PWM module as a pulse-width modulated digital waveform. On some dsPIC33F devices the output can be generated by the Digital-to-Analog Conversion module as a pair of differential signals.

A PWM output signal is converted to an analog signal by a low-pass filter on the Audio PICtail Plus Daughter Board. A Digital-to-Analog Converter (DAC) signal pair is converted to a single-ended analog signal by a differential amplifier on the Audio PICtail Plus Daughter Board.

The output signals from the Audio PICtail Plus Daughter Board are then appropriately amplified for the selected output type (line or speaker).

The Explorer 16 board supplies power to the Audio PICtail Plus Daughter Board.

The Audio PICtail Plus Daughter Board is shown in Figure 1-1.

Audio PICtail™ Plus Daughter Board User's Guide

FIGURE 1-1: AUDIO PICtail™ PLUS DAUGHTER BOARD

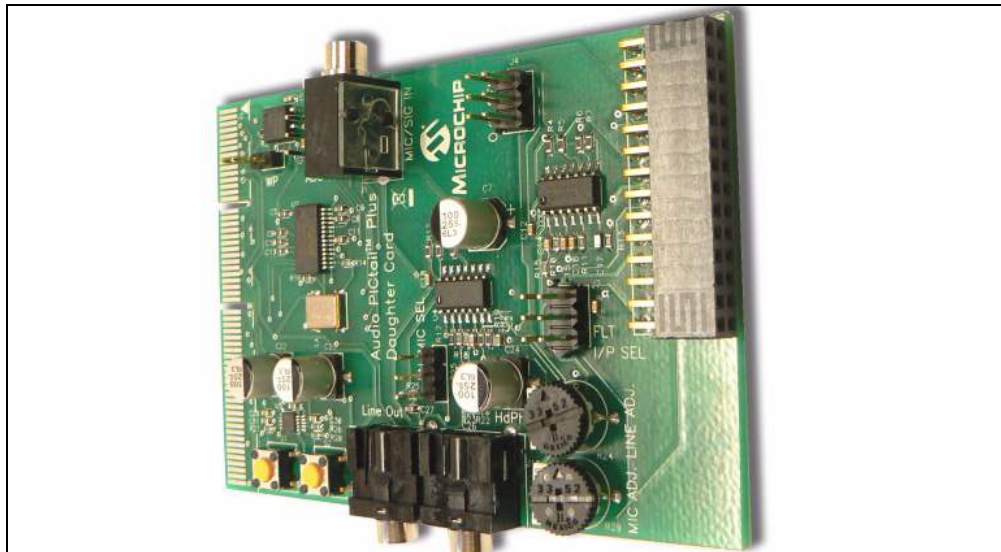

1.2 BOARD SETUP

Figure 1-2 is a photograph of Audio PICtail Plus Daughter Board plugged into Explorer 16 Development Board. A microphone and speaker are connected to the Audio PICtail Plus Daughter Board. The power supply and MPLAB ICD 2 are plugged into the Explorer 16 board. When the included demonstration software is loaded into the dsPIC33F or PIC24H device, the voice input to the microphone is looped back to the speakers, demonstrating voice-quality audio without the use of a codec device.

FIGURE 1-2: AUDIO PICtail™ PLUS DAUGHTER BOARD SETUP

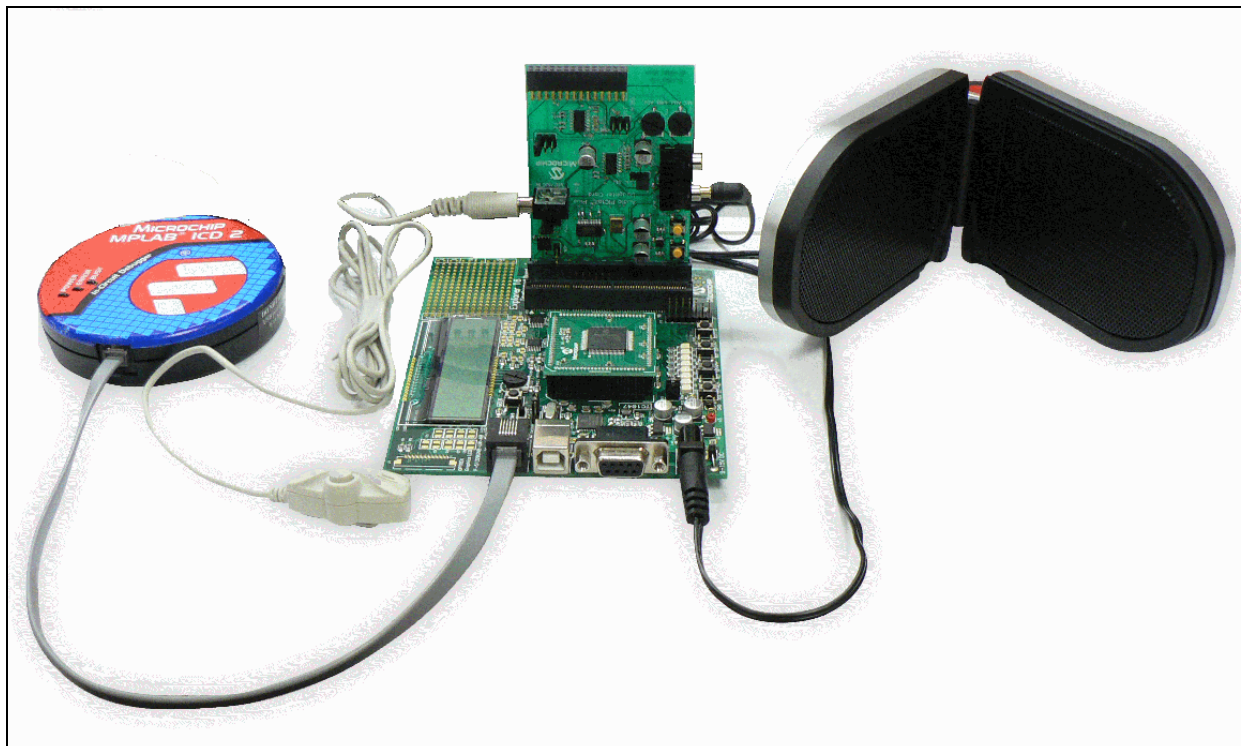

1.3 REFERENCE DOCUMENTS

In addition to the Recommended Reading listed in the Preface, the following manufacturers' data sheets are also recommended as reference sources:

- *National Semiconductor Corporation Data Sheet, LM4811 Boomer[®] Audio Power Amplifier Series Dual 105 mW Headphone Amplifier with Digital Volume Control and Shutdown Mode (DS200061)*
- *Wolfson Microelectronics Data Sheet, WM8510 Mono CODEC with Speaker Driver, Production Data December 2006, Rev. 4.1*
- *Atmel Corporation Data Sheet, AT25F4096 4-Mbit High Speed SPI Serial Flash Memory (24546–SFLSH–05/06)*

Audio PICtail™ Plus Daughter Board User's Guide

NOTES:

Chapter 2. Hardware

This chapter provides a functional overview of the Audio PICtail Plus Daughter Board and identifies the major hardware components. Topics covered include:

- Functional Overview
- Hardware Components

2.1 FUNCTIONAL OVERVIEW

The block diagram shown in Figure 2-1 illustrates the mainstream operation of the Audio PICtail Plus Daughter Board.

FIGURE 2-1: AUDIO PICtail™ PLUS DAUGHTER BOARD BLOCK DIAGRAM

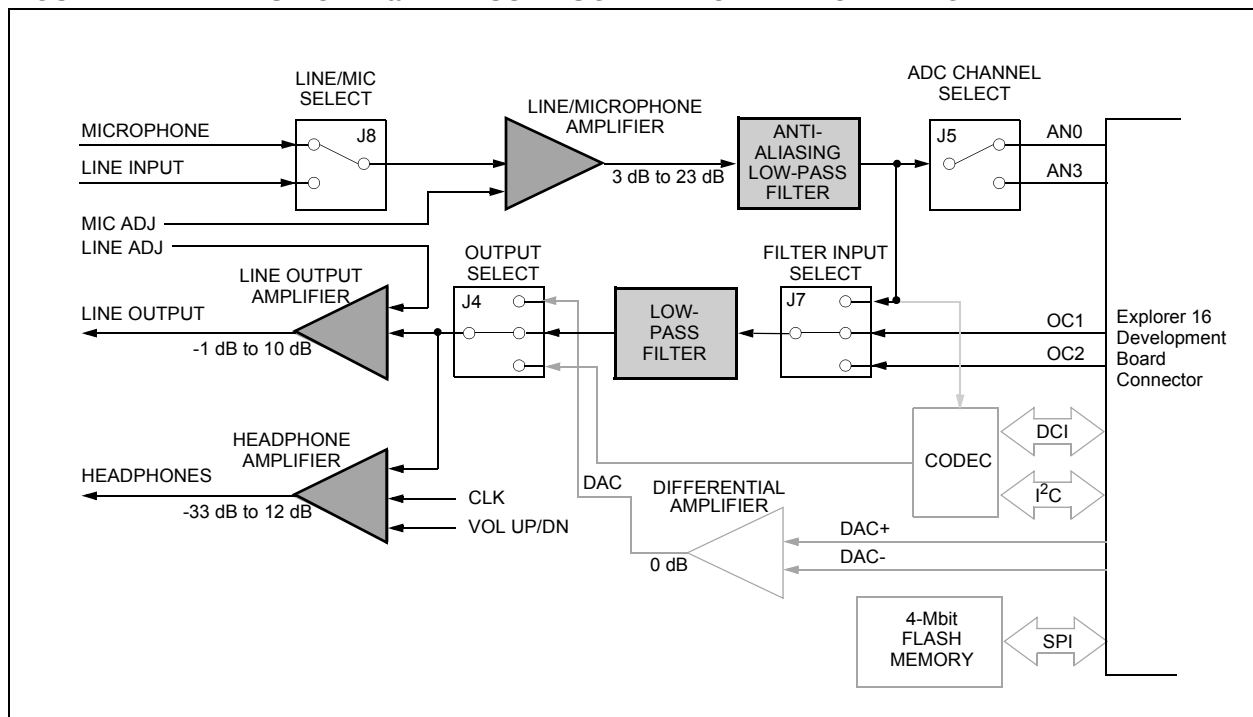

2.1.1 Speech Sampling

The incoming audio signal can come from a line input or a condenser microphone. The speech sampling input is jumper selected (J8). The selected signal is amplified by a non-inverting AC amplifier (Line/Microphone Amplifier) and routed to the ADC module on the dsPIC33F or PIC24H device through an anti-aliasing filter. This second-order Sallen-Key low-pass filter has a cutoff frequency of 3300 Hz. The ADC Channel Select Jumper (J5) selects the input signal line (AN0 or AN3). If the input to the amplifier is a condenser microphone, a bias voltage provides a working supply voltage for the microphone. The line input does not require this bias voltage.

The amplifier has a variable gain from 3 dB to 23 dB, which can be adjusted to control microphone sensitivity or boost a low line-input signal. The output of the amplifier is biased at 1.65V.

Audio PICtail™ Plus Daughter Board User's Guide

2.1.2 Speech Playback

The mainstream speech playback interface processes the pulse-width modulated digital signal from the Output Compare PWM module of the dsPIC33F or PIC24H device. A low-pass filter demodulates the PWM signal as shown in Figure 2-2. The low-pass filter behaves like an integrator whose output signal amplitude depends on the duty cycle of the input PWM waveform. The PWM frequency should be an integral multiple of the audio sampling rate.

FIGURE 2-2: PWM DEMODULATION

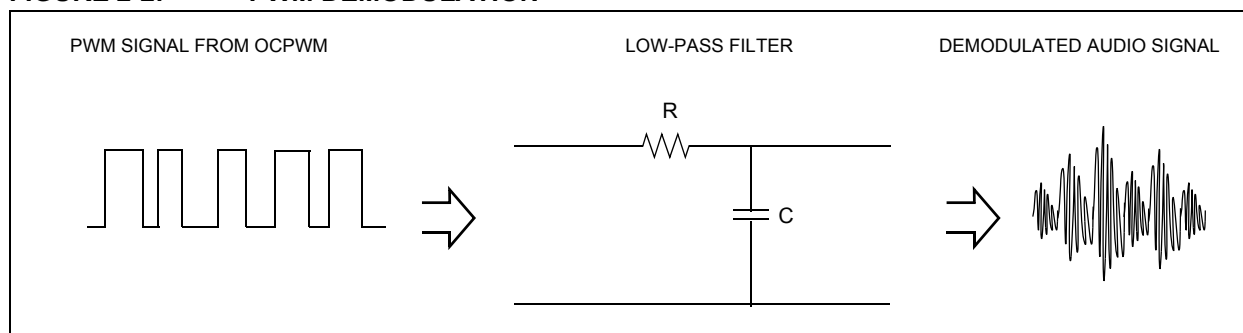

The output of the low-pass filter feeds both the Line Output and Headphone amplifiers (through Output Select Jumper J4). The Line Output amplifier drives external audio recording equipment or an external audio power amplifier. The amplifier is an AC inverting amplifier with adjustable gain. The gain can be adjusted to match the input level requirements of the external audio equipment, and can be varied from -1 dB to 10 dB.

The headphone amplifier drives an audio headphone. This amplifier can drive up to 75 mW into a 32 ohm headphone. The amplifier uses a digital volume control that is controlled by the clock switch and the control switch.

Volume is increased by pressing and releasing the clock switch while holding the control switch down. Volume is decreased by pressing and releasing the clock switch without operating the control switch.

2.1.3 Codec

The optional codec is supported by dsPIC33F devices only. The input is fixed to the amplified incoming signal from the Line/Microphone amplifier. The output feeds both the Line Output and Headphone amplifiers (through Output Select Jumper J4).

The codec must interact with the application program running on the dsPIC33F. Commands from the application program control the codec operating parameters (such as communication protocol, sampling rate, volume control, level control, filter settings, etc.). Command information is exchanged over the Inter-Integrated Circuit™ (I²C) module on the dsPIC33F.

The codec converts the incoming audio signal to a digital signal for the Digital Converter Interface (DCI) module of the dsPIC33F. Audio output from the application program is sent to the codec via the DCI module. The codec converts this digital signal to audio for the Line Output and Headphone amplifiers.

2.1.4 DAC Differential Amplifier

The DAC Differential Amplifier allows the Audio PICtail Plus Daughter Board to interface with the DAC module on dsPIC33F devices. Audio output from the DAC module is a pair of differential analog signals. The DAC Differential amplifier converts this complementary signal pair into a single-ended audio signal for the Microphone and Line Output amplifiers. The DAC Differential amplifier provides 0 dB gain.

2.1.5 4-Mb Serial Flash Memory

The Audio PICtail Plus Daughter Board includes 4-Mb serial Flash memory that can be used for storing data. The memory interfaces with the SPI bus on dsPIC33F and PIC24H devices and might typically be used by applications that require storage of speech samples for playback purposes.

2.2 HARDWARE COMPONENTS

Figure 2-3 identifies the key Audio PICtail Plus Daughter Board hardware components.

FIGURE 2-3: AUDIO PICtail™ PLUS DAUGHTER BOARD

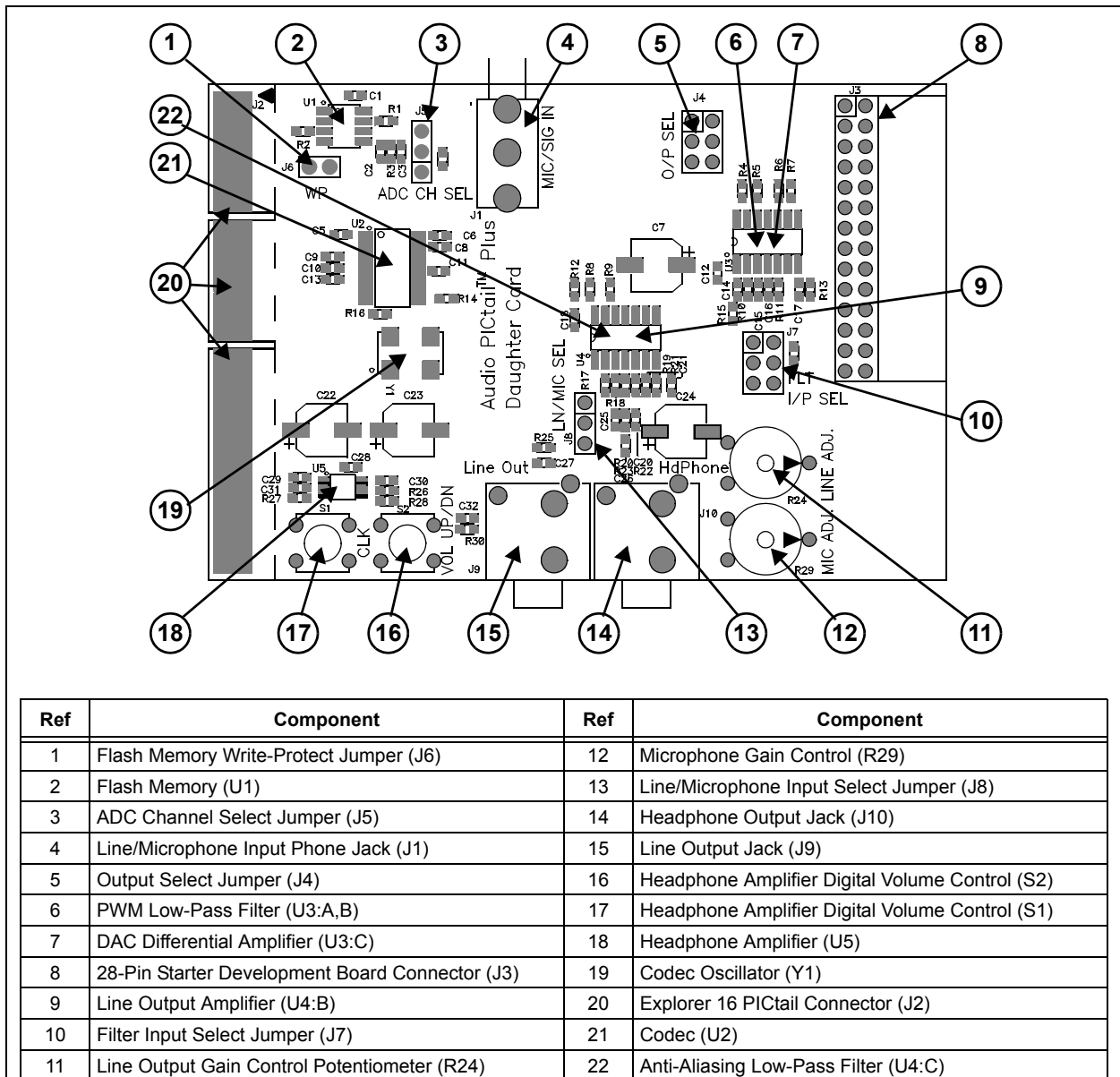

Audio PICtail™ Plus Daughter Board User's Guide

2.2.1 Line/Microphone Input Phone Jack (J1)

The Line/Microphone Input (Ref 4) is a 3.5 mm mono input phone jack (MJ3502). This connection accepts either a condenser microphone or a line level signal (see schematic in Figure A-2).

2.2.2 Line/Microphone Input Select Jumper (J8)

The Line/Microphone Input Select Jumper (Ref 13) determines if the Microphone/Line Pre-Amplifier (U4:A) operates as a line amplifier or a microphone amplifier. If the MIC option is selected, a bias voltage of +5V is applied to the Line/Microphone Input Phone Jack (J1), as shown in the schematic in Figure A-2.

2.2.3 Line/Microphone Pre-Amplifier (U4:A)

The Microphone/Line Pre-Amplifier (Ref 9) is implemented using one of the four op amps on the MCP6024 quad op amp IC (U4). The output of this non-inverting AC amplifier is biased at 1.65V. The gain of the amplifier is controlled by Potentiometer R29, as given by Equation 2-1.

EQUATION 2-1: INPUT PRE-AMPLIFIER GAIN

$$\text{Gain} = 1 + \left(\frac{R29 + R17}{R3} \right)$$

See Figure A-2 for the complete schematic of the Line/Microphone Pre-Amplifier.

2.2.4 Anti-Aliasing Low-Pass Filter (U4:C)

The Anti-Aliasing Low-Pass Filter uses one of the four operational amplifiers on the MCP6024 quad op amp IC (U4). The output of the Line/Microphone Pre-Amplifier (Ref 22) uses an anti-aliasing low-pass second-order Sallen-Key structure to filter the signal and provide a cut-off frequency of 3300 Hz.

See Figure A-3 for a schematic of the Anti-Aliasing Low-Pass Filter.

2.2.5 Microphone Gain Control (R29)

MIC ADJ Potentiometer R29 (Ref 12) controls the gain of the Line/Microphone Pre-Amplifier (U4:A).

Note: Setting the gain too high can cause the output of the amplifier to saturate and clip.

See Figure A-2 for the complete schematic of the Line/Microphone Pre-Amplifier.

2.2.6 ADC Channel Select Jumper (J5)

The ADC Channel Select Jumper (Ref 3) is used to select the analog-to-digital input channel (AN0 or AN3) on the dsPIC33F or PIC24H device on the Explorer 16 Development Board.

To use channel AN0, place the jumper between pins 2 and 3 on the ADC CH SEL header (see Figure A-2). To use channel AN3, place the jumper between pins 1 and 2.

2.2.7 PWM Low-Pass Filter (U3:A,B)

The PWM signal from the Output Compare PWM module on the dsPIC33F or PIC24H device on the Explorer 16 board is demodulated by the PWM low-pass filter (Ref 6). This fourth order filter uses two of the four op amps (U3:A and U3:B) on the MCP6024 quad op amp IC.

The input to the filter is selected by the Filter Input Select Jumper (J7). The output of the filter is routed to the headphone and line output amplifiers via the Output Select Jumper (J4).

The complete schematic of the low-pass filter, the input select jumper and the output select jumper is shown in Figure A-4.

2.2.8 Filter Input Select Jumper (J7)

The input to the PWM Low-Pass Filter is selected by the FLT I/P SEL Jumper (Ref 10). This jumper allows the following inputs to be selected:

- OCPWM channel 1 output (OC1) of the dsPIC33F or PIC24H device on the Explorer 16 board
- OCPWM channel 2 output (OC2) of the dsPIC33F or PIC24H device on the Explorer 16 board
- Output of the Line/Microphone Pre-Amplifier (MIC_SIG)

2.2.9 Output Select Jumper (J4)

The Output Select Jumper (Ref 5) determines whether the input signal for the Line Output and Headphone Amplifiers comes from the PWM Filter, the codec or the differential amplifier that converts a digital audio signal from the dsPIC33F device.

See Figure A-4 for circuit details.

2.2.10 Line Output Amplifier (U4:B)

The Line Output Amplifier is implemented using one of the four op amps on the MCP6024 quad op amp IC (Ref 9). The output of this inverting AC amplifier is intended to drive an external audio amplifier or recording device. The signal is AC-coupled to the Line Output Jack (J9).

The gain of the amplifier is controlled by the Line Adjust Potentiometer (R24), as given by Equation 2-2.

EQUATION 2-2: LINE OUTPUT AMPLIFIER GAIN

$$\text{Gain} = \frac{(R24 + R19)}{R21}$$

See Figure A-4 for a complete schematic of the Line Output Amplifier.

2.2.11 Line Output Gain Control Potentiometer (R24)

LINE ADJ potentiometer R24 (Ref 11) controls the gain of the Line Output Amplifier (U4:B).

Note: Setting the gain too high can cause the output of the amplifier to saturate and clip.

See Figure A-4 for a complete schematic of the Line Output Amplifier.

Audio PICtail™ Plus Daughter Board User's Guide

2.2.12 Line Output Jack (J9)

Line out jack J9 (Ref 15) is a 3.5 mm stereo socket that can be used to connect the output of the line output amplifier to an external power amplifier or recording equipment.

See Figure A-4 for a complete schematic of the Line Output Amplifier.

2.2.13 Headphone Amplifier (U5)

The Headphone Amplifier (Ref 18) is a National Semiconductor LM4811 70 mW stereo amplifier with digital volume control. The input to the amplifier is controlled by the setting of Output Select Jumper (J4). The output of the amplifier is available at Headphone Output Jack (J10).

Gain is controlled by the voltage levels applied through the CLK switch (S1) and VOL UP/DN switch (S2). Each time the CLK switch is pressed, the gain increases or decreases by 3 dB, depending on the status of the VOL UP/DN switch. If both switches are pressed, the gain increases on the leading edge of the CLK signal. If only the CLK switch is pressed, the gain decreases on the leading edge of the CLK signal. The gain can be adjusted over a range of +12 dB to -33 dB in 16 discrete gain settings.

See Figure A-4 for a complete schematic of the Headphone Amplifier.

2.2.14 Headphone Amplifier Digital Volume Control

Volume is increased by pressing and releasing the CLK switch (Ref 17) while holding down the VOL UP/DN switch (Ref 16). Volume is decreased by pressing and releasing the CLK switch without operating the VOL UP/DN switch.

See Figure A-4 for a complete schematic of the Headphone Amplifier.

2.2.15 Headphone Output Jack (J10)

The Headphone Jack (Ref 14) is a 3.5 mm stereo connector. A 32 ohm headphone can be connected to this socket.

See Figure A-4 for a complete schematic of the Headphone Amplifier.

2.2.16 DAC Differential Amplifier (U3:C)

The DAC Differential Amplifier (Ref 7) allows the Audio PICtail Plus Daughter Board to interface with the Digital-to-Analog Converter module on dsPIC33F devices. Audio output from the DAC module is a pair of buffered differential analog signals. The DAC Differential amplifier converts this complementary signal pair into a single-ended audio signal for the Microphone and Line Output amplifiers.

This amplifier uses one of the four op amps (U3:C) on the MCP6024 quad op amp IC (Ref 7). The DAC Differential Amplifier provides 0 dB gain.

See Figure A-4 for a complete schematic of the DAC Differential Amplifier.

2.2.17 Codec (U2)

The Audio PICtail Plus Daughter Board includes an optional codec (Ref 21) that interfaces to the DCI module (data interface) and I²C bus (control interface) of the dsPIC33F device on the Explorer 16 board. It is also AC coupled to the output of the Line/Microphone Amplifier (MIC_SIG).

The codec is a Wolfson WM8510 and uses oscillator Y1 for clocking.

See Figure A-5 for a complete schematic of the Codec.

2.2.18 Codec Oscillator (Y1)

Codec Oscillator Y1 (Ref 19) provides a required 12 MHz master clock signal to the 16-bit Codec (U2).

See Figure A-5 for a complete schematic of the Codec.

2.2.19 Flash Memory (U1)

The Audio PICtail Plus Daughter Board includes a serial Flash memory chip (Ref 2). This memory is write protected when the jumper pin is inserted in WP (Jumper J6).

See Figure A-6 for a complete schematic of the Flash memory circuit.

2.2.20 Flash Memory Write-Protect Jumper (J6)

When the jumper pin is inserted in WP (Ref 1), write operations to the serial Flash memory have no effect.

2.2.21 Explorer 16 PICtail Connector (J2)

The Audio PICtail Plus Daughter Board connects to the Explorer 16 board using edge connector J3 (Ref 20). The Audio PICtail Plus Daughter Board uses these Explorer 16 signals:

- +3.3V power
- +5V power
- Ground
- dsPIC33F device DCI module signals
- dsPIC33F or PIC24H Output Compare module signals
- dsPIC33F or PIC24H SPI 2 module signals
- dsPIC33F or PIC24H I2C 2 module signals
- dsPIC33F or PIC24H ADC module inputs

2.2.22 28-Pin Starter Development Board Connector (J3)

The 28-Pin Starter Development Board Connector (Ref 8) allows the Audio PICtail Plus Daughter Board to be connected to Microchip's 28-Pin Starter Development Board.

CAUTION

To avoid damage to the Audio PICtail Plus Daughter Board, the 28-Pin Starter Development Board must operate a +3.3V when it is connected to the Audio PICtail Plus Daughter Board.

Audio PICtail™ Plus Daughter Board User's Guide

NOTES:

Chapter 3. PWM Speech Loopback Demo

This chapter describes a simple program that demonstrates how to use the Audio PICtail Plus Daughter Board for speech capture and loopback without the use of a codec. Topics covered include:

- Speech Loopback Demo
- Running the Demo

3.1 SPEECH LOOPBACK DEMO

The CD that accompanies the Audio PICtail Plus Daughter Board contains a Speech Loopback Demo application. As shown in Figure 3-1, this sample application uses the Audio PICtail Plus Daughter Board to capture an input microphone signal and deliver the captured signal to the dsPIC33F device on the Explorer 16 board for audio processing. The application program running on the dsPIC33F or PIC24H then:

- Compresses the incoming digital signal from 16 bits to 8 bits using the G.711 μ -law encoding algorithm
- Decompresses the 8-bit signal back to 16 bits using the G.711 μ -law decoding algorithm
- Outputs the decompressed signal to the OC PWM module, where it is converted to a Pulse-Width Modulated signal.

FIGURE 3-1: SPEECH LOOPBACK DEMO OVERVIEW

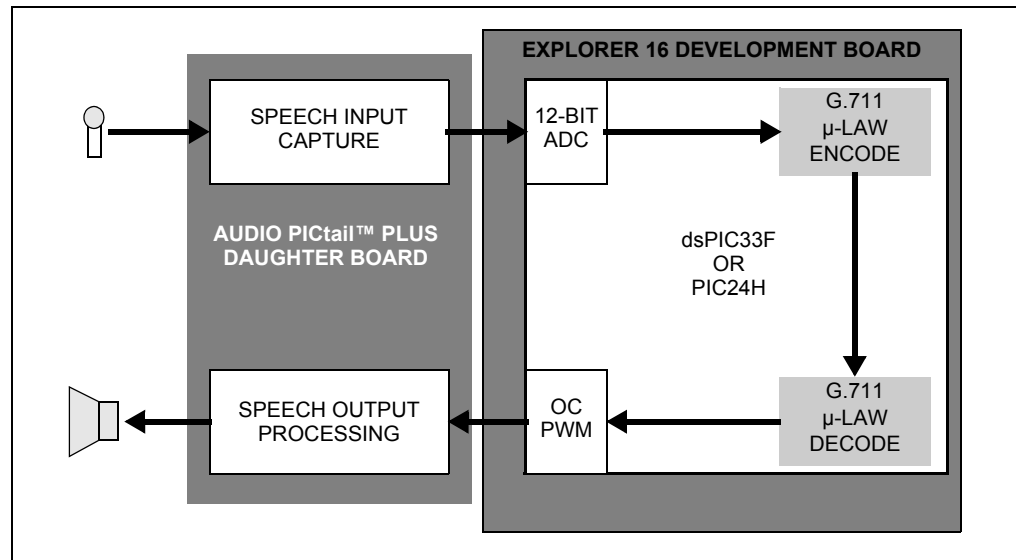

The Audio PICtail Plus Daughter Board then processes the PWM signal through the PWM filter to produce an analog audio signal. This signal is amplified and output through the speaker.

As a result, audio spoken into the microphone is digitally processed without the use of a codec device and played back through the speaker.

Audio PICtail™ Plus Daughter Board User's Guide

The demo program consists of these basic software elements:

- ADC Driver
- Output Compare Module Driver
- Loopback Application Software

3.1.1 ADC Driver

The ADC driver reads the incoming signal on the specified 12-bit ADC channel (either AN0 or AN3), as determined by the ADC CH SEL jumper (J9). The driver interface is specified in the file `ADCChannelDrv.h`. The driver is implemented in `ADCChannelDrv.c` file.

The ADC driver uses DMA Channel 0 to read data from the ADC register. The DMA channel is configured for continuous ping-pong operation, which allows the application to read one buffer while the DMA is populating the other buffer. Buffer memory must be allocated by the user application.

Parameters such as instruction cycle frequency, sampling rate, buffer size and ADC module configuration are set in the `ADCChannelDrv.h` header file. Refer to the driver documentation on the CD for details.

3.1.2 Output Compare Module Driver

The Output Compare PWM (OCPWM) Driver uses the Output Compare module to convert digital data to a PWM signal. Either Output Compare Channel 1 or Channel 2 can be used. The driver interface is specified in the file `OCPWMDrv.h` and the driver is implemented in `OCPWMDrv.c` file.

The driver uses DMA Channel 1 to write data to the OCxRS register in the Output Compare PWM module. This channel is configured for continuous ping-pong operation. The buffers for the driver must be allocated by the user application.

The Timer 2 module on the dsPIC33F or PIC24H device is configured for the maximum PWM time period. The driver maps the input sample value to a time period, which is then loaded into the OCxRS register. The OC output stays high until the Timer 2 value matches the OCxRS register time period and then stays low for the rest of the PWM period. This way the duty cycle of the OC PWM signal is proportional to the input digital sample.

Parameters such as instruction cycle frequency, sampling rate, buffer size and PWM carrier frequency are set in the `OCPWMDrv.h` header file. Refer to the driver documentation on the CD for details.

PWM Speech Loopback Demo

3.1.3 Loopback Application Software

The Loopback application on the accompanying CD uses the ADC and OCPWM drivers to read and output speech signals with the Audio PICtail Plus board. The application will loopback the microphone signal to the headphone output after performing a G.711 encode/decode operation on the microphone signal. Figure 3-2 is a flow chart of the demo application.

FIGURE 3-2: APPLICATION FLOW CHART

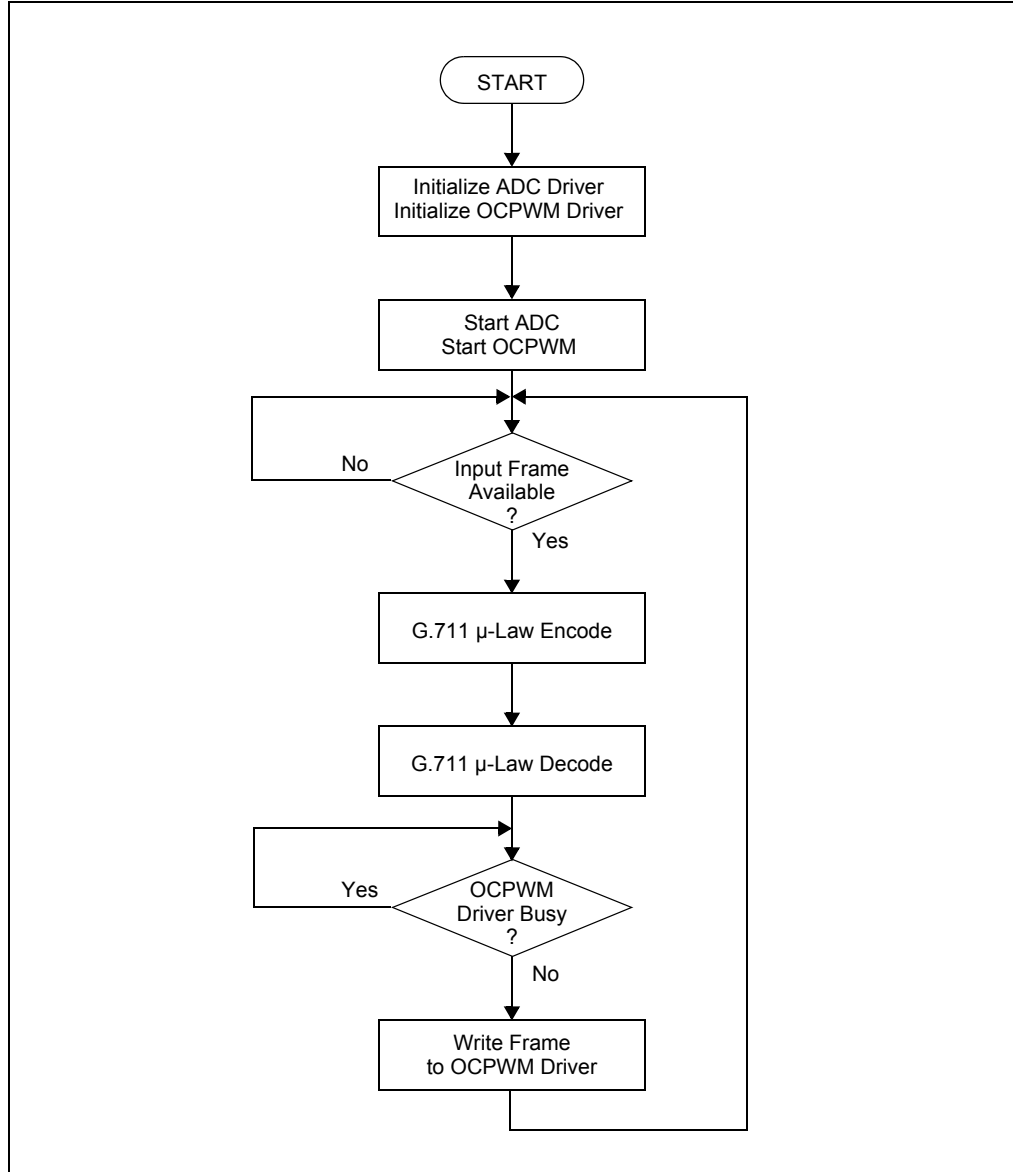

Audio PICtail™ Plus Daughter Board User's Guide

3.2 RUNNING THE DEMO

To run the demo, follow these basic steps:

1. Copy the demo programs from the Audio PICtail Plus Daughter Board CD to your MPLAB project folder.
2. With the Audio PICtail Plus Daughter Board plugged into the Explorer 16 Development Board, set up the Explorer 16 board to run with MPLAB IDE (using either MPLAB ICE or REAL ICE).

For detailed instructions on setting up the Explorer 16 Development Board, refer to the *“Explorer 16 Development Board User's Guide”* (DS51589).

3. Open the demo program project in MPLAB IDE.
4. Build the application and program the dsPIC33F or PIC24H device.
5. Run the program.
6. Connect the microphone and speaker.
7. With the application running, speak into the microphone and note the resulting playback on the speaker.

Appendix A. Drawings and Schematics

This appendix provides detailed technical drawings and schematic diagrams of the Audio PICtail Plus Daughter Board.

A.1 AUDIO PICtail PLUS DAUGHTER BOARD LAYOUT

Figure A-1: Audio PICtail Plus Daughter Board Layout is a drawing of the Audio PICtail Plus Daughter Board layout.

FIGURE A-1: AUDIO PICtail™ PLUS DAUGHTER BOARD LAYOUT

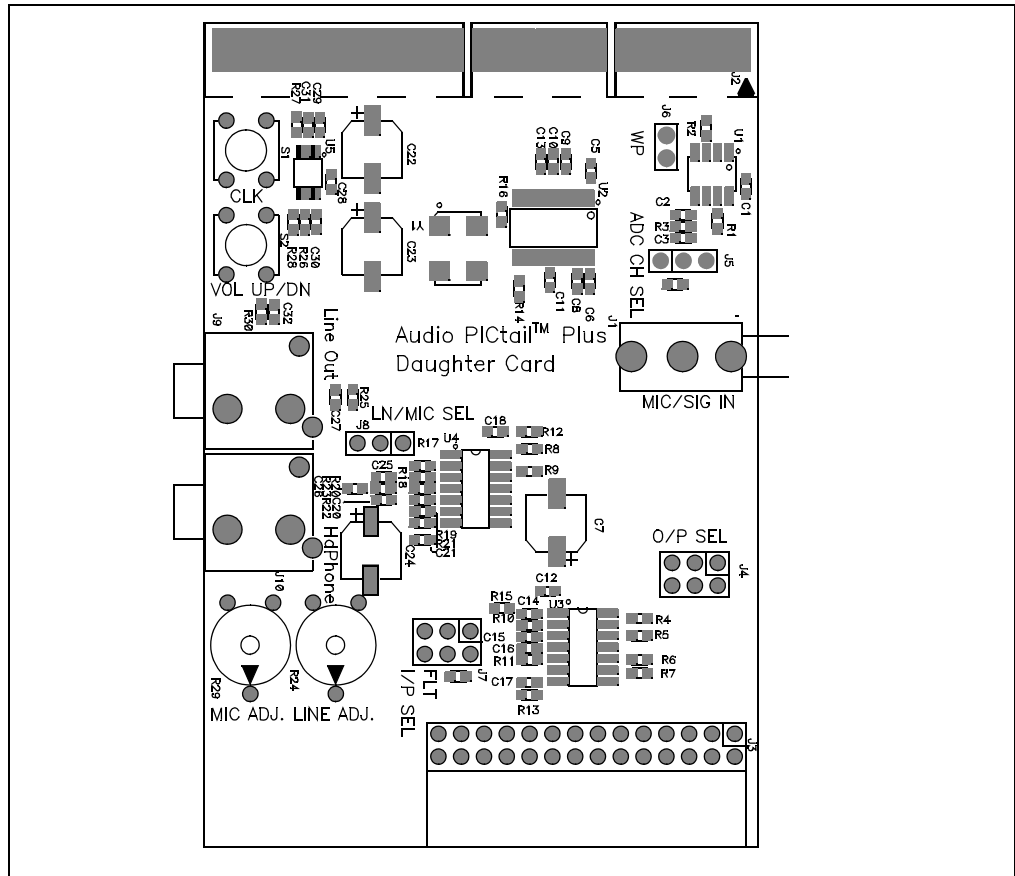

A.2 SCHEMATIC DIAGRAMS

The following schematic diagrams are included in this appendix:

- Figure A-2: Speech Sampling Interface Schematic
- Figure A-3: Anti-Aliasing Low-Pass Filter Schematic
- Figure A-4: Speech Playback Interface Schematic
- Figure A-5: Codec Schematic
- Figure A-6: Flash Memory Schematic
- Figure A-7: Board Connectors

Audio PICtail™ Plus Daughter Board User's Guide

FIGURE A-2: SPEECH SAMPLING INTERFACE SCHEMATIC

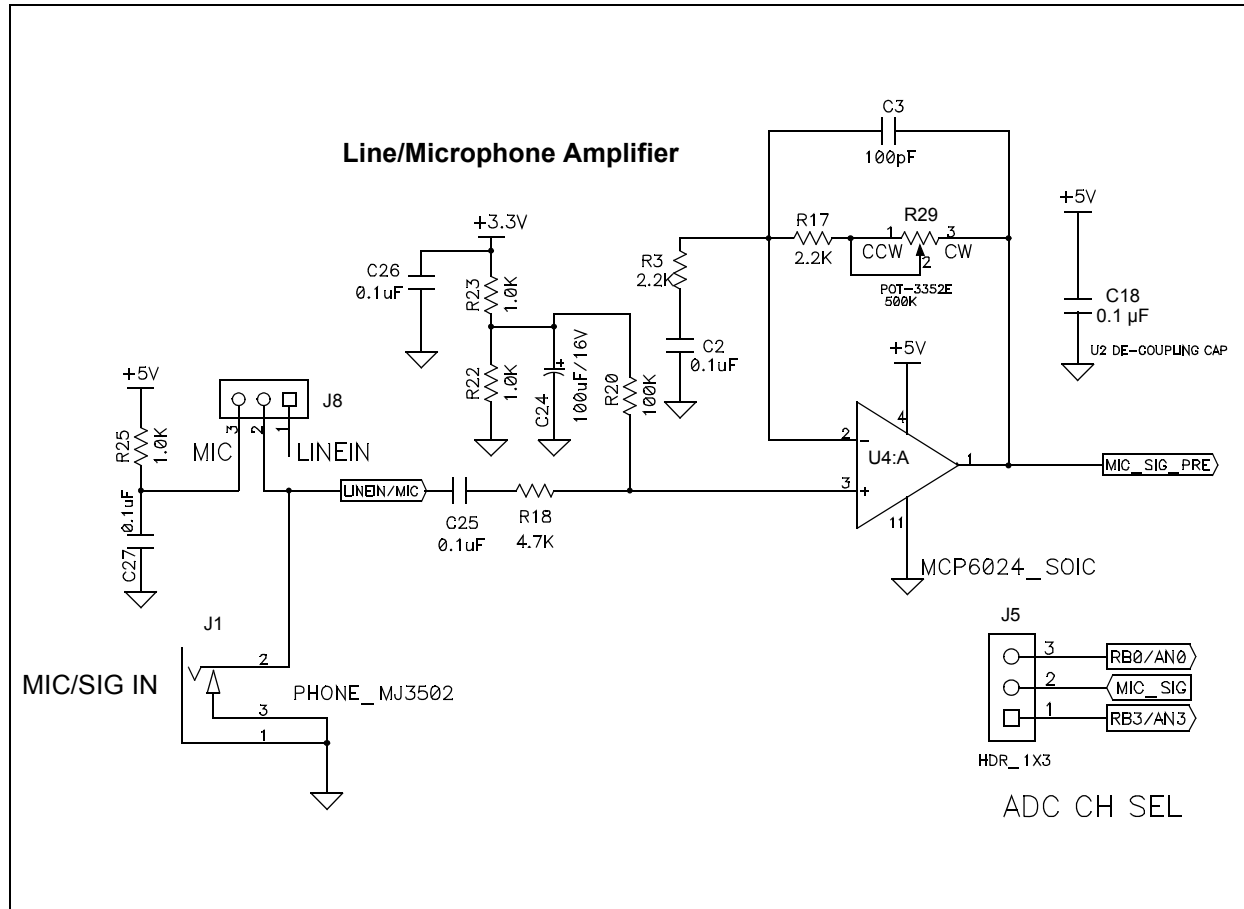

FIGURE A-3: ANTI-ALIASING LOW-PASS FILTER SCHEMATIC

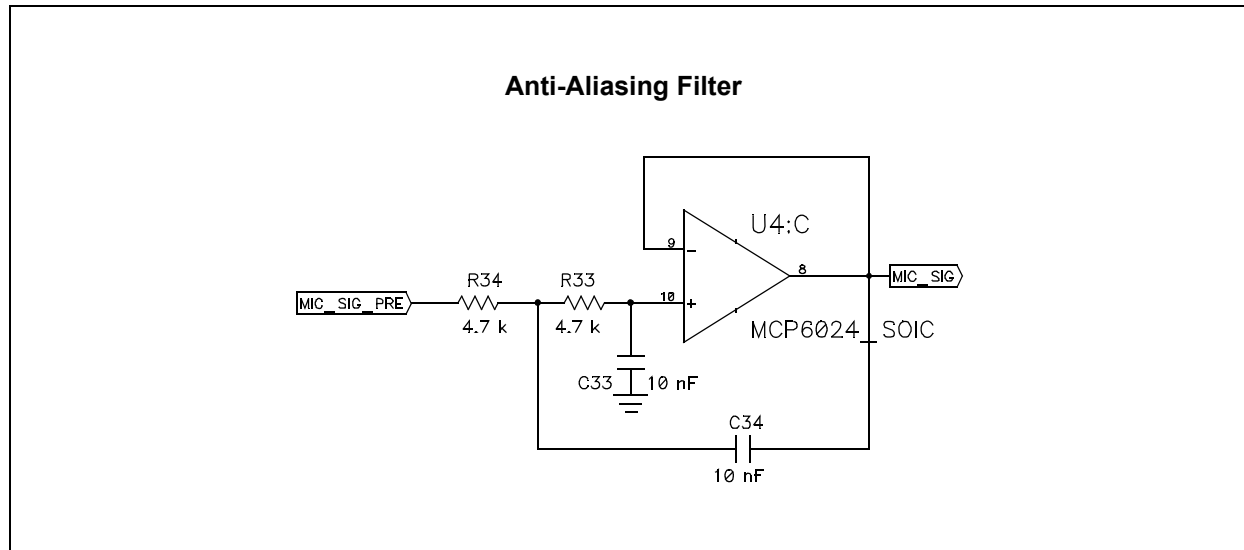
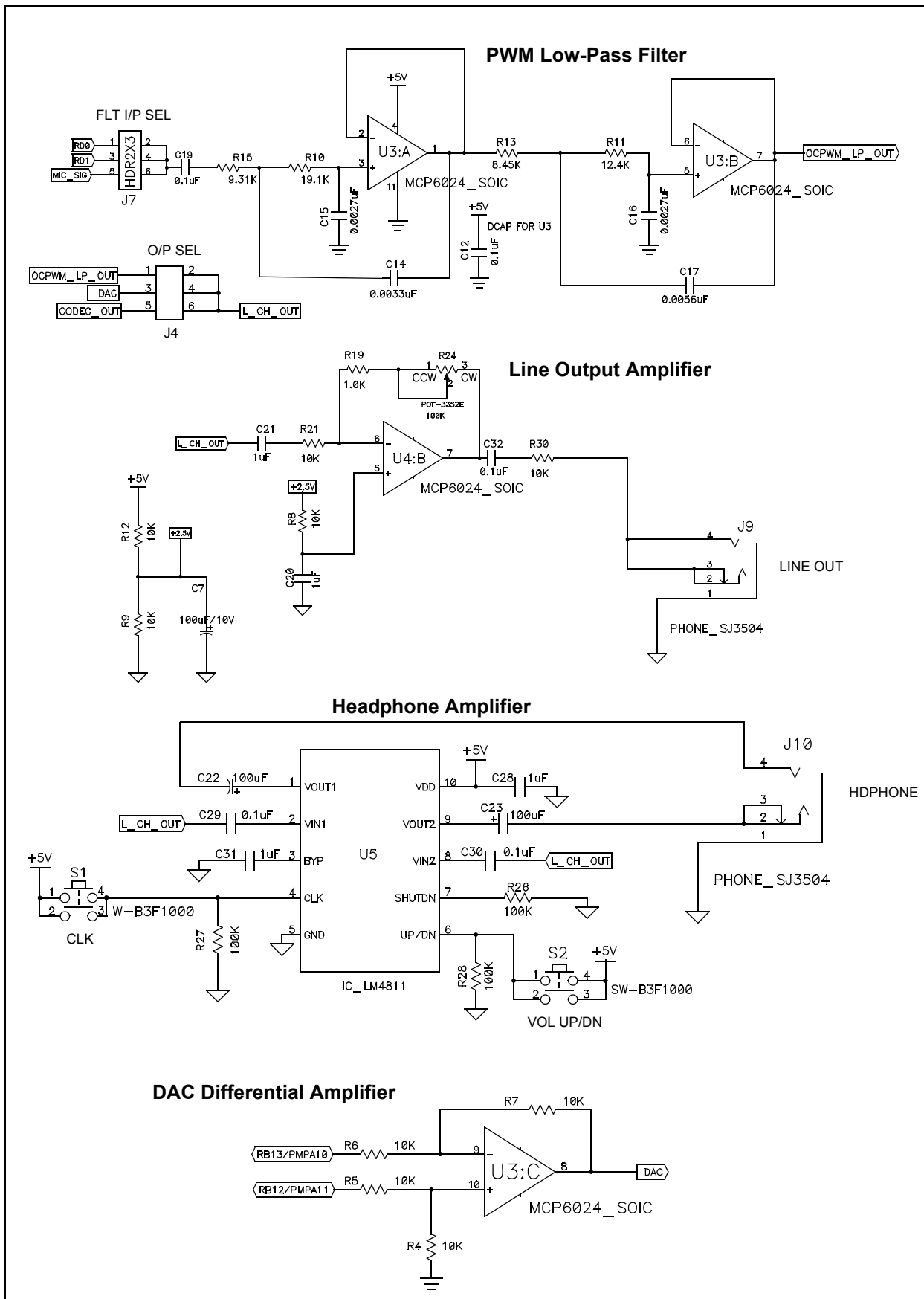

FIGURE A-4: SPEECH PLAYBACK INTERFACE SCHEMATIC



Audio PICtail™ Plus Daughter Board User's Guide

FIGURE A-5: CODEC SCHEMATIC

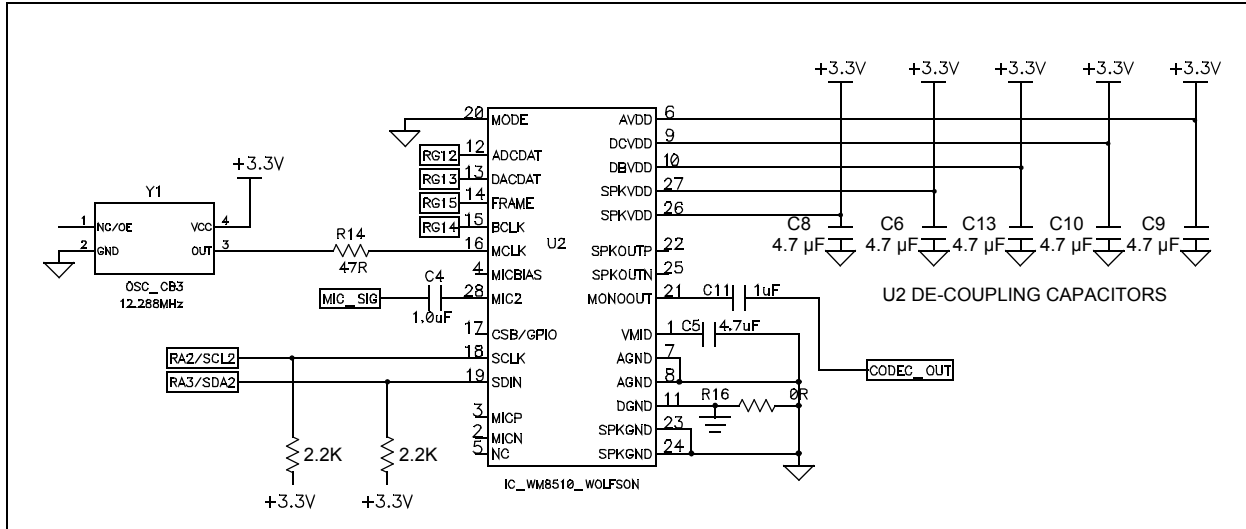

FIGURE A-6: FLASH MEMORY SCHEMATIC

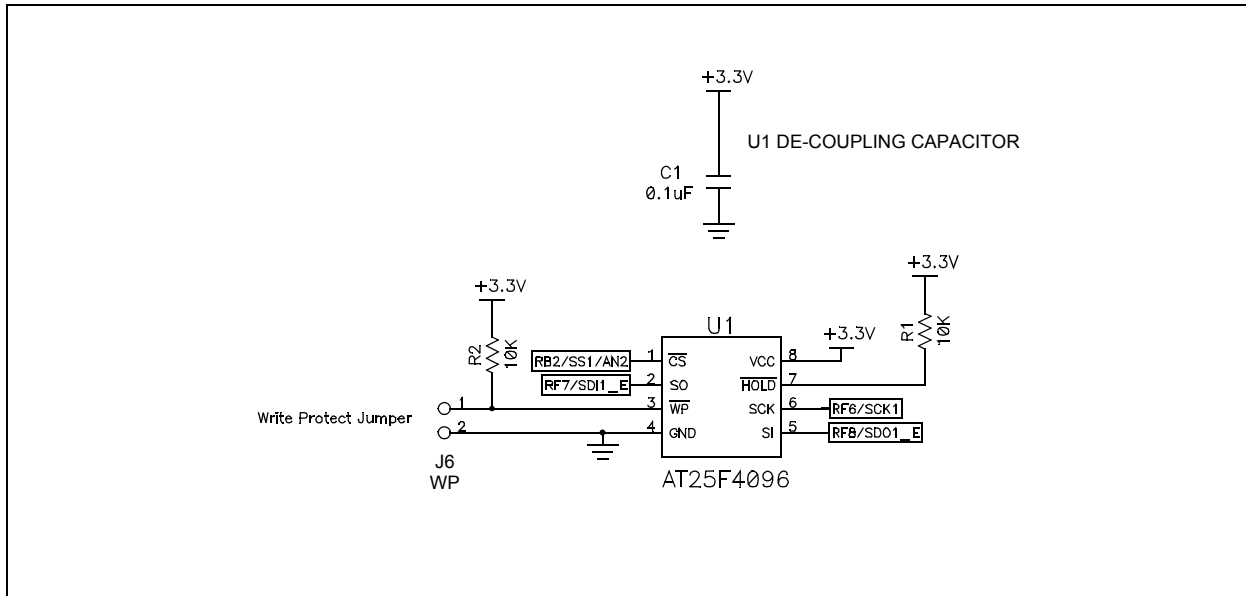
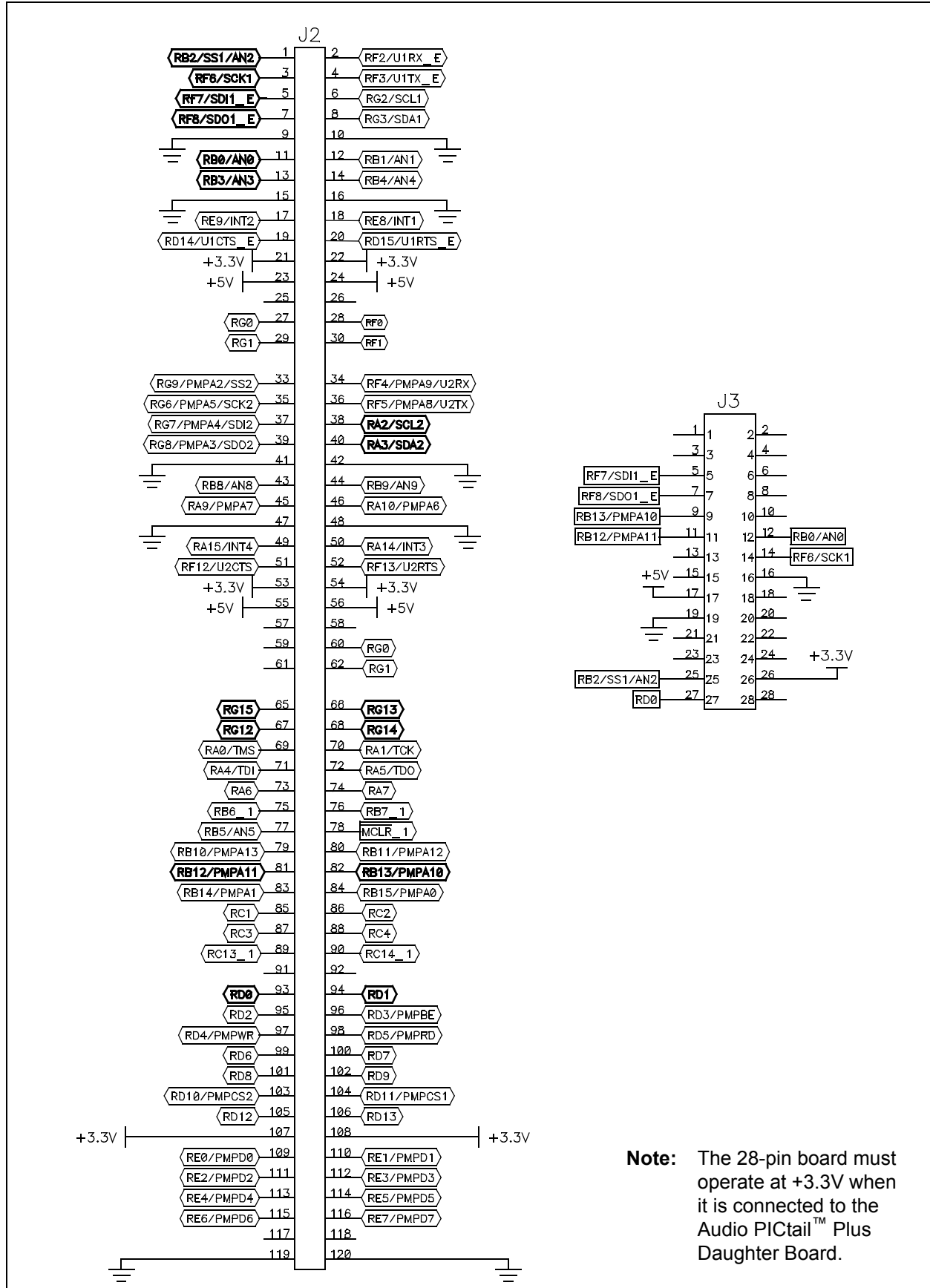

FIGURE A-7: BOARD CONNECTORS



Note: The 28-pin board must operate at +3.3V when it is connected to the Audio PICtail™ Plus Daughter Board.

Audio PICtail™ Plus Daughter Board User's Guide

NOTES:



AUDIO PICTail™ PLUS DAUGHTER BOARD USER'S GUIDE

Index

A		R	
ADC Driver	20	Reading, Recommended	3
B		S	
Bias Voltage	11	Schematic Diagrams	23
Board Connectors Schematic	27	Single-Ended Signal.....	7
Board Layout.....	23	Speech Sampling Input	11
C		Speech Sampling Interface Schematic	24
Codec.....	12	W	
Codec Schematic	26	Warranty Registration	3
Customer Notification Service	5	WWW Address	4
Customer Support	5		
D			
DAC Differential Amplifier	12		
Demo Block Diagram	19		
Demo Flow Chart	21		
Differential Signals	7		
Digital Volume Control	12		
Documentation			
Conventions	2		
Layout	1		
F			
Flash Memory	13		
Flash Memory Schematic.....	26		
G			
G.711 μ -law Algorithm	19		
H			
Hardware Components	13		
I			
Input Signal Line	11		
Internet Address.....	4		
L			
Line Input	11		
Line Output Amplifier	12		
M			
Manufacturers' Data Sheets	9		
Microchip Internet Web Site.....	4		
O			
OCPWM Driver	20		
P			
Ping-Pong Operation	20		
Playback	12		
PWM Output Signal	7		



WORLDWIDE SALES AND SERVICE

AMERICAS

Corporate Office
2355 West Chandler Blvd.
Chandler, AZ 85224-6199
Tel: 480-792-7200
Fax: 480-792-7277
Technical Support:
<http://support.microchip.com>
Web Address:
www.microchip.com

Atlanta

Duluth, GA
Tel: 678-957-9614
Fax: 678-957-1455

Boston

Westborough, MA
Tel: 774-760-0087
Fax: 774-760-0088

Chicago

Itasca, IL
Tel: 630-285-0071
Fax: 630-285-0075

Dallas

Addison, TX
Tel: 972-818-7423
Fax: 972-818-2924

Detroit

Farmington Hills, MI
Tel: 248-538-2250
Fax: 248-538-2260

Kokomo

Kokomo, IN
Tel: 765-864-8360
Fax: 765-864-8387

Los Angeles

Mission Viejo, CA
Tel: 949-462-9523
Fax: 949-462-9608

Santa Clara

Santa Clara, CA
Tel: 408-961-6444
Fax: 408-961-6445

Toronto

Mississauga, Ontario,
Canada
Tel: 905-673-0699
Fax: 905-673-6509

ASIA/PACIFIC

Asia Pacific Office
Suites 3707-14, 37th Floor
Tower 6, The Gateway
Harbour City, Kowloon
Hong Kong
Tel: 852-2401-1200
Fax: 852-2401-3431

Australia - Sydney
Tel: 61-2-9868-6733
Fax: 61-2-9868-6755

China - Beijing
Tel: 86-10-8528-2100
Fax: 86-10-8528-2104

China - Chengdu
Tel: 86-28-8665-5511
Fax: 86-28-8665-7889

China - Fuzhou
Tel: 86-591-8750-3506
Fax: 86-591-8750-3521

China - Hong Kong SAR
Tel: 852-2401-1200
Fax: 852-2401-3431

China - Nanjing
Tel: 86-25-8473-2460
Fax: 86-25-8473-2470

China - Qingdao
Tel: 86-532-8502-7355
Fax: 86-532-8502-7205

China - Shanghai
Tel: 86-21-5407-5533
Fax: 86-21-5407-5066

China - Shenyang
Tel: 86-24-2334-2829
Fax: 86-24-2334-2393

China - Shenzhen
Tel: 86-755-8203-2660
Fax: 86-755-8203-1760

China - Shunde
Tel: 86-757-2839-5507
Fax: 86-757-2839-5571

China - Wuhan
Tel: 86-27-5980-5300
Fax: 86-27-5980-5118

China - Xian
Tel: 86-29-8833-7252
Fax: 86-29-8833-7256

ASIA/PACIFIC

India - Bangalore
Tel: 91-80-4182-8400
Fax: 91-80-4182-8422

India - New Delhi
Tel: 91-11-4160-8631
Fax: 91-11-4160-8632

India - Pune
Tel: 91-20-2566-1512
Fax: 91-20-2566-1513

Japan - Yokohama
Tel: 81-45-471- 6166
Fax: 81-45-471-6122

Korea - Daegu
Tel: 82-53-744-4301
Fax: 82-53-744-4302

Korea - Seoul
Tel: 82-2-554-7200
Fax: 82-2-558-5932 or
82-2-558-5934

Malaysia - Kuala Lumpur
Tel: 60-3-6201-9857
Fax: 60-3-6201-9859

Malaysia - Penang
Tel: 60-4-227-8870
Fax: 60-4-227-4068

Philippines - Manila
Tel: 63-2-634-9065
Fax: 63-2-634-9069

Singapore
Tel: 65-6334-8870
Fax: 65-6334-8850

Taiwan - Hsin Chu
Tel: 886-3-572-9526
Fax: 886-3-572-6459

Taiwan - Kaohsiung
Tel: 886-7-536-4818
Fax: 886-7-536-4803

Taiwan - Taipei
Tel: 886-2-2500-6610
Fax: 886-2-2508-0102

Thailand - Bangkok
Tel: 66-2-694-1351
Fax: 66-2-694-1350

EUROPE

Austria - Wels
Tel: 43-7242-2244-39
Fax: 43-7242-2244-393

Denmark - Copenhagen
Tel: 45-4450-2828
Fax: 45-4485-2829

France - Paris
Tel: 33-1-69-53-63-20
Fax: 33-1-69-30-90-79

Germany - Munich
Tel: 49-89-627-144-0
Fax: 49-89-627-144-44

Italy - Milan
Tel: 39-0331-742611
Fax: 39-0331-466781

Netherlands - Drunen
Tel: 31-416-690399
Fax: 31-416-690340

Spain - Madrid
Tel: 34-91-708-08-90
Fax: 34-91-708-08-91

UK - Wokingham
Tel: 44-118-921-5869
Fax: 44-118-921-5820

10/05/07