



User manual

## **UM EN WF 1000**

Stripping machine with integrated graphic display,  
for conductors and cables up to 6 mm in diameter

## User manual

### Stripping machine with integrated graphic display, for conductors and cables up to 6 mm in diameter

2012-04-30

---

Designation: UM EN WF 1000

Revision: 02

Order No.: —

This user manual is valid for:

Designation	Order No.
WF 1000	1212149
WF 1000 120V	1212258

---

## Please observe the following notes

### User group of this manual

The use of products described in this manual is oriented exclusively to qualified electricians or persons instructed by them, who are familiar with applicable standards and other regulations regarding electrical engineering and, in particular, the relevant safety concepts.

### Explanation of symbols used and signal words



This is the safety alert symbol. It is used to alert you to potential personal injury hazards. Obey all safety measures that follow this symbol to avoid possible injury or death.

There are three different categories of personal injury that are indicated with a signal word.

**DANGER** This indicates a hazardous situation which, if not avoided, will result in death or serious injury.

**WARNING** This indicates a hazardous situation which, if not avoided, could result in death or serious injury.

**CAUTION** This indicates a hazardous situation which, if not avoided, could result in minor or moderate injury.



This symbol together with the signal word **NOTE** and the accompanying text alert the reader to a situation which may cause damage or malfunction to the device, hardware/software, or surrounding property.



This symbol and the accompanying text provide the reader with additional information or refer to detailed sources of information.

### How to contact us

#### Internet

Up-to-date information on Phoenix Contact products and our Terms and Conditions can be found on the Internet at:

[www.phoenixcontact.com](http://www.phoenixcontact.com)

Make sure you always use the latest documentation.

It can be downloaded at:

[www.phoenixcontact.net/catalog](http://www.phoenixcontact.net/catalog)

#### Subsidiaries

If there are any problems that cannot be solved using the documentation, please contact your Phoenix Contact subsidiary.

Subsidiary contact information is available at [www.phoenixcontact.com](http://www.phoenixcontact.com).

#### Published by

PHOENIX CONTACT GmbH & Co. KG  
Flachsmarktstraße 8  
32825 Blomberg  
GERMANY

Should you have any suggestions or recommendations for improvement of the contents and layout of our manuals, please send your comments to:

[tecdoc@phoenixcontact.com](mailto:tecdoc@phoenixcontact.com)

**Please observe the following notes**

---

**General terms and conditions of use for technical documentation**

Phoenix Contact reserves the right to alter, correct, and/or improve the technical documentation and the products described in the technical documentation at its own discretion and without giving prior notice, insofar as this is reasonable for the user. The same applies to any technical changes that serve the purpose of technical progress.

The receipt of technical documentation (in particular user documentation) does not constitute any further duty on the part of Phoenix Contact to furnish information on modifications to products and/or technical documentation. You are responsible to verify the suitability and intended use of the products in your specific application, in particular with regard to observing the applicable standards and regulations. All information made available in the technical data is supplied without any accompanying guarantee, whether expressly mentioned, implied or tacitly assumed.

In general, the provisions of the current standard Terms and Conditions of Phoenix Contact apply exclusively, in particular as concerns any warranty liability.

This manual, including all illustrations contained herein, is copyright protected. Any changes to the contents or the publication of extracts of this document is prohibited.

Phoenix Contact reserves the right to register its own intellectual property rights for the product identifications of Phoenix Contact products that are used here. Registration of such intellectual property rights by third parties is prohibited.

Other product identifications may be afforded legal protection, even where they may not be indicated as such.

# Table of contents

1	Basic information .....	1-1
	1.1 Intended use.....	1-1
	1.2 Workplaces .....	1-2
	1.3 For your safety.....	1-2
2	Description of the WF 1000 .....	2-1
	2.1 Supplied as standard.....	2-1
	2.2 Overview of the operating components .....	2-2
3	Starting up and operating the WF 1000 .....	3-1
	3.1 Setup and connection.....	3-1
	3.2 Setting parameters and stripping.....	3-2
	3.3 Maintenance and shutting down.....	3-4
4	Troubleshooting .....	4-1
	4.2 Cable not clamped .....	4-2
	4.3 Blade will not cut.....	4-2
	4.4 Blade will not open .....	4-2
	4.5 Replacing the blades and clamping jaws.....	4-3
	4.6 Replacing the mains fuse .....	4-4
A	Technical appendix.....	A-1
	A 1 Ordering data .....	A-1
	A 2 Technical data.....	A-1
	A 3 Declaration of conformity.....	A-2



# 1 Basic information

For safe handling and trouble-free operation of the WF 1000, you must be familiar with and observe the safety notes.

## 1.1 Intended use

**WARNING: The WF 1000 is designed exclusively for stripping**

The WF 1000 is designed exclusively for stripping single and multi-strand circular conductors in the cross-section range 0.08 - 6 mm<sup>2</sup> (28 - 10 AWG).

Very hard insulation will damage the stripping blades and must not be used.

Under no circumstances should solid metal parts or similar objects be inserted, as these can damage the stripping blades and clamping jaws.

Unauthorized conversions that exceed the scope of modification, and changes to the WF 1000 are not permitted for safety reasons.



**NOTE:** Correct usage includes observing all notes and complying with the predefined operating conditions.



**WARNING:** The WF 1000 may only be used

- as intended and
- when in safe and fault-free condition.



**WARNING:** All persons responsible for startup, operation, and maintenance of the WF 1000 must be appropriately qualified and adhere strictly to this user manual.

### Permitted operators

Only authorized and instructed operators may work with the WF 1000.

The operator is responsible for all other persons within the workspace.

The owner must make the user manual available to the operator and ensure that the operator has read and understood it.



**WARNING:** Only use original replacement parts from Phoenix Contact.

## 1.2 Workplaces



**NOTE:** During operation and storage, avoid the following:

- humid or dusty places and
- locations exposed to high levels of heat, direct sunlight or low temperatures (operating range: 10°C to 40°C).



**NOTE:** Do not spill liquids on the WF 1000.

Do not expose the WF 1000 to strong vibrations or shocks.

## 1.3 For your safety



**WARNING:** The protective cover is fitted for the safety of the operator. Under no circumstances must it be modified, removed or bypassed by means of alterations.



**WARNING:** The WF 1000 must only be operated with the receptacle tray fitted and intact, as this also acts as a protective cover.

Switch off the WF 1000 during breaks and when the device is not being used.

For reasons of safety, the WF 1000 automatically switches off when the protective cover is removed.



**WARNING:** Disconnect the mains plug before opening the housing.



## 2 Description of the WF 1000

### 2.1 Supplied as standard

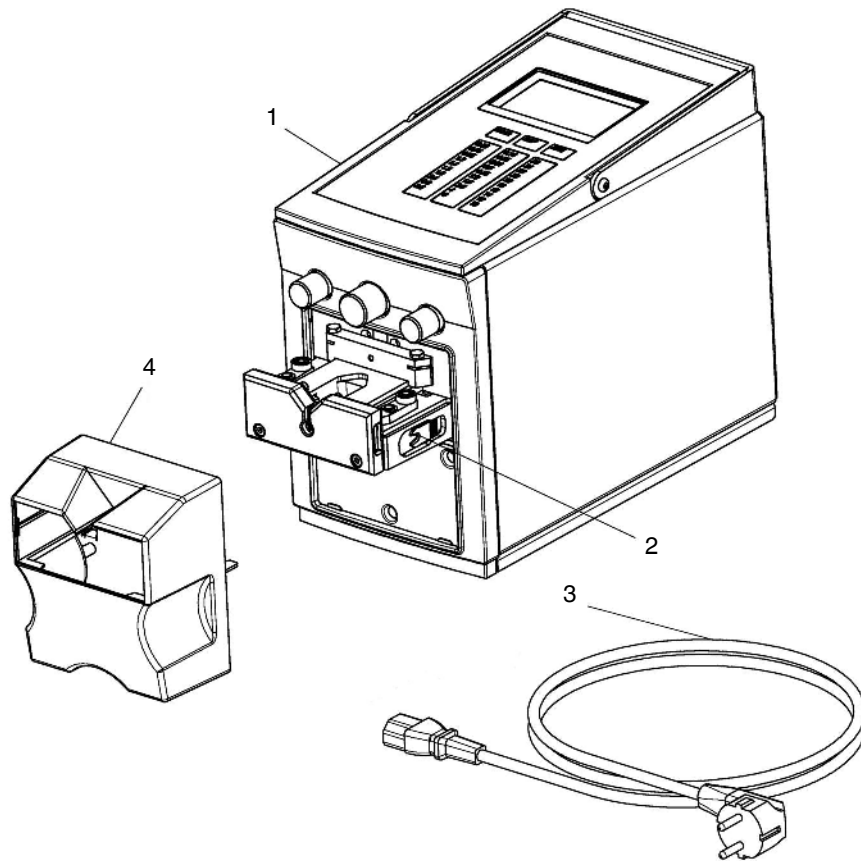

Figure 2-1 Supplied as standard

- 1 Basic device WF 1000
  - 2 Cable centering aid
  - 3 Power cable
  - 4 Receptacle tray (protective cover)
- User manual

## 2.2 Overview of the operating components

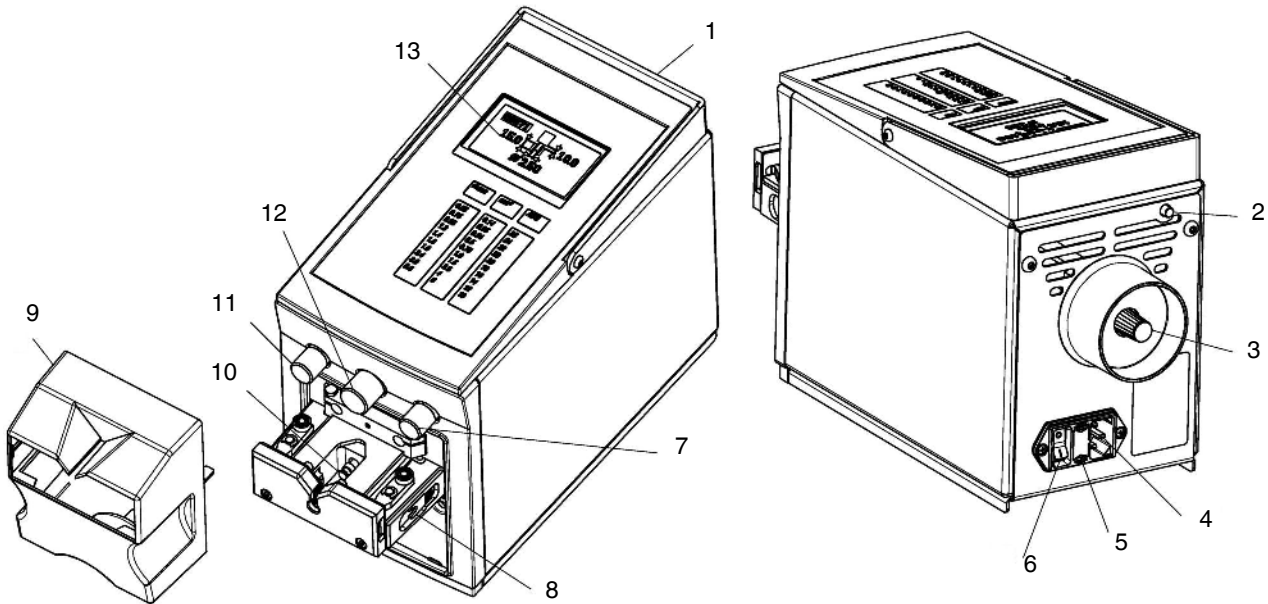
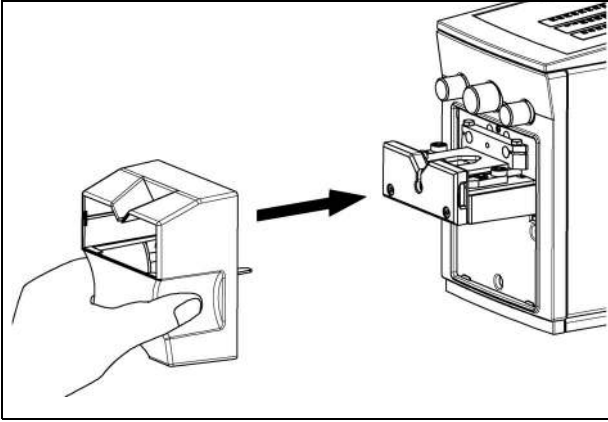

Figure 2-2 Operating components

<b>1</b> Carrier handle	Used for transport.	<b>8</b> Cable centering aid	Simplifies the stripping of thin conductors.
<b>2</b> Button	Used to reset the counter and acknowledge messages or entries.	<b>9</b> Receptacle tray (protective cover)	Acts as a protective cover and is also used to catch the stripped insulation.
<b>3</b> Motor axis	Manual operation	<b>10</b> Start button	When the cable is inserted the start button is pressed and stripping is started.
<b>4</b> Mains connection	Device connection for the power cable.	<b>11</b> Stripping length knob	Used to set the stripping length.
<b>5</b> Mains fuse	Fine fuses integrated in the mains connection (2 pcs).	<b>12</b> Diameter knob	Used to set the conductor diameter (cutting depth).
<b>6</b> Mains switch	Switches the power supply on/off. The LCD lights up when switched on.	<b>13</b> LCD	Displays settings, messages, and errors.
<b>7</b> Removal length knob	Used to set the removal length. If the value is greater than the stripping length, the remaining insulation is completely removed from the cable. If the value is smaller, the insulation is partially removed.		

## 3 Starting up and operating the WF 1000

### 3.1 Setup and connection



#### Setting up the WF 1000



**NOTE:** The device must be set up on a level and horizontal surface.



**NOTE: During operation and storage, avoid the following:**

- humid or dusty places and
- locations exposed to high levels of heat, direct sunlight or low temperatures (operating range: 10°C ... 40°C).

- Attach the receptacle tray.

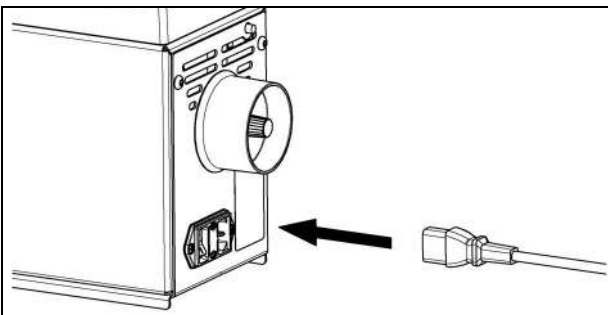

#### Connecting the WF 1000



**WARNING:** The WF 1000 is available in two versions for 230 V and 120 V. Make sure that the mains connection is correct (see rating plate).

- Connect the mains plug to the mains connection.
- Switch on the WF 1000 via the mains switch (press I). The LCD lights up.

### 3.2 Setting parameters and stripping

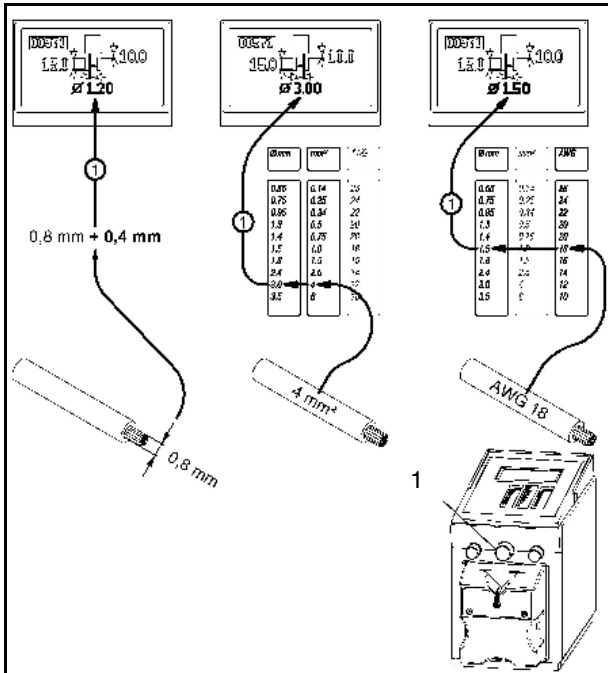

#### Setting the diameter



**NOTE:** First, set the diameter of the conductor to prevent damage to the stripping blades.

- Determine the diameter of the conductor (in mm) and add **0.4 mm leeway**, to ensure that the WF 1000 does not cut into the conductor.  
For example: measured diameter 0.8 mm + 0.4 mm = 1.20 mm
- Alternatively, the conductor cross section (mm²) or AWG values can be converted into the corresponding mm diameter value using the printed table. The leeway value is already included in the calculation.
- Set the calculated value via the middle knob (1).

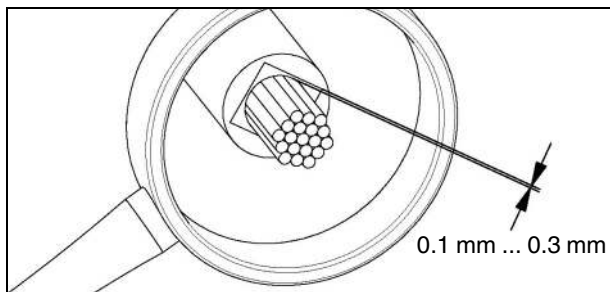

#### Correcting the diameter



**NOTE:** The cut must stop 0.1 to 0.3 mm from the conductor so that it does not damage it.

- Check the cutting depth with a test cut and correct the setting if necessary.

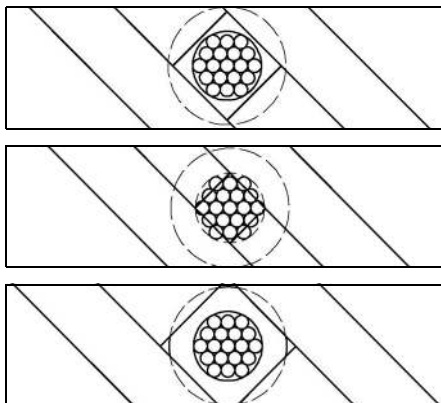

- There is sufficient safety distance between the blades and conductor and the insulation is removed cleanly.

- The blades cut too deeply into the conductor.



**NOTE:** The blades may be damaged.

- The blades do not cut deep enough into the insulation.

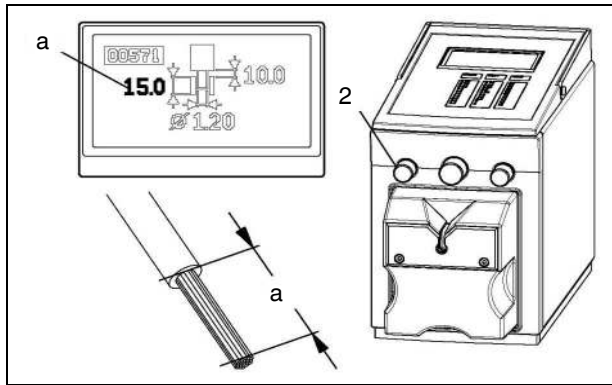
**Setting the stripping length (a)**

- Set the desired stripping length (mm) using the left-hand knob (2).

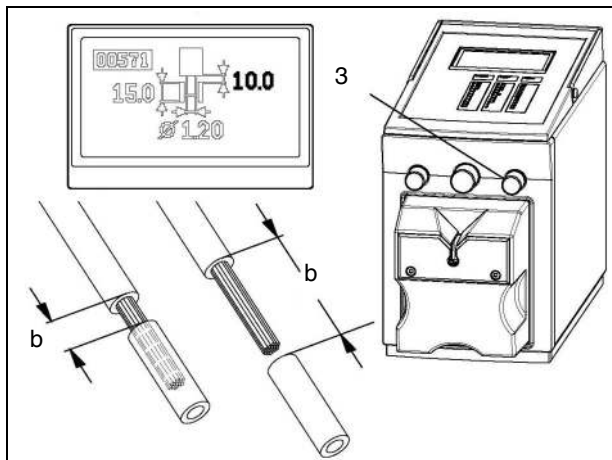
**Setting the removal length (b)**

- Set the desired removal length (mm) using the right-hand knob (3).  
The remaining insulation can be partially or completely removed.

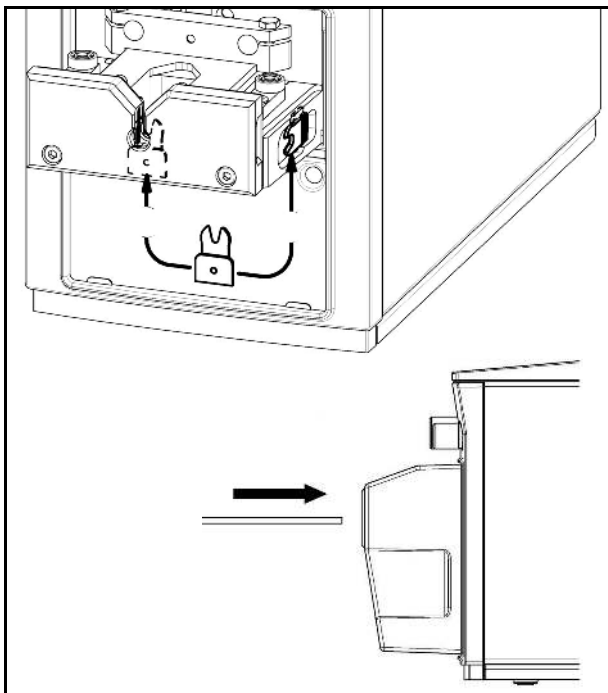
**Stripping**

**NOTE:** Conductors inserted at an angle can result in malfunctions.

- Insert the conductor **horizontally** into the WF 1000.
  - Conductor cross section **up to**  $\text{Ø } 2.4 \text{ mm}$  **with** cable centering aid
  - Conductor cross section **over**  $\text{Ø } 2.4 \text{ mm}$  **without** cable centering aid
- Push the start button as close to the center as possible.

### 3.3 Maintenance and shutting down

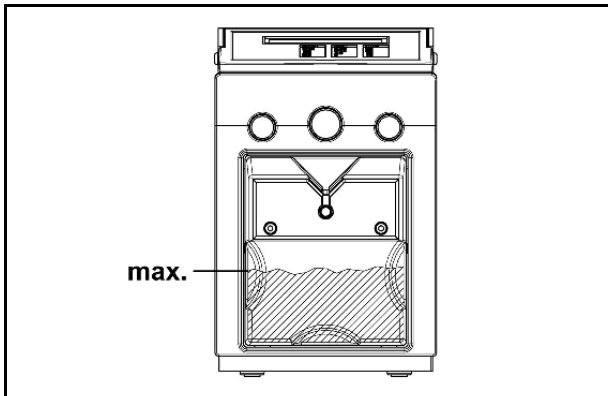

#### Emptying the receptacle tray



**NOTE:** Make sure that the receptacle tray does not become too full.

- Empty the receptacle tray regularly to prevent malfunctions.

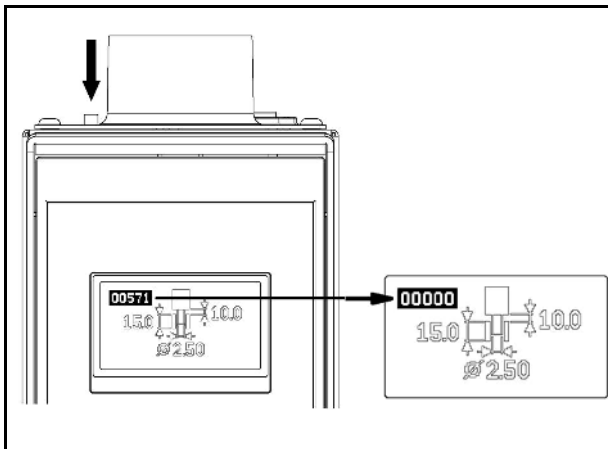

#### Resetting the counter to zero (reset)

- Press the button on the rear of the device to set the counter to zero.

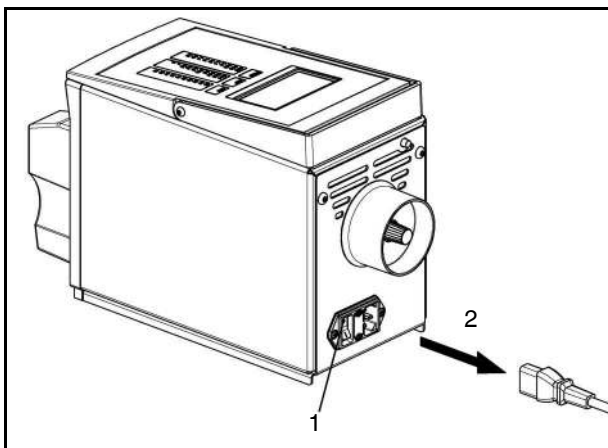







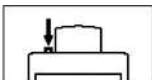

#### Shutting down

- Switch off the WF 1000 via the mains switch (1) (press 0) and disconnect the mains plug from the device (2).

# 4 Troubleshooting

## 4.1 Error messages

Table 4-1 Troubleshooting

Display	Reason	Remedy
No display	No mains connection.	<ul style="list-style-type: none"> <li>Check the mains fuse and replace if necessary (see page 4-4).</li> </ul>
	Receptacle tray missing.	<ul style="list-style-type: none"> <li>Attach the receptacle tray.</li> </ul>
	The button must be pressed.	<ul style="list-style-type: none"> <li>Press the reset button.</li> </ul> <div style="border: 1px solid black; padding: 5px; margin-top: 10px;">  <p><b>WARNING: Risk of injury</b> The WF 1000 starts by moving from its initial position.</p> </div>
	The sensor for the start button does not respond properly when the machine is switched on.	<ul style="list-style-type: none"> <li>Disconnect the WF 1000 from the mains.</li> <li>Remove the start button and clean it.</li> <li>Blow down the metal pipe carefully with compressed air.</li> </ul>
	The sensor for the front limit position is not activated when the machine is started. The contact is not established.	<ul style="list-style-type: none"> <li>Switch the WF 1000 off.</li> <li>Wait until the display goes out and then switch the WF 1000 back on.</li> <li>If the error message does not disappear:                             <ul style="list-style-type: none"> <li>Switch the WF 1000 off.</li> <li>Remove the receptacle tray.</li> <li>Remove the clamping jaw cartridge.</li> <li>Check for foreign objects between the blade cover and clamp (1).</li> <li>Check whether any of the screws on the blade cover have come loose (2).</li> </ul> </li> </ul>
	The sensor for the rear turning point is activated, even though the device should be in the start position.	<ul style="list-style-type: none"> <li>Check the settings on the display.</li> <li>Switch the WF 1000 off.</li> <li>Wait until the display goes out and then switch the WF 1000 back on.</li> </ul>
	The maximum time for the stripping process was exceeded.	
	The maximum motor current was exceeded.	
	The receptacle tray was removed during the operating cycle.	

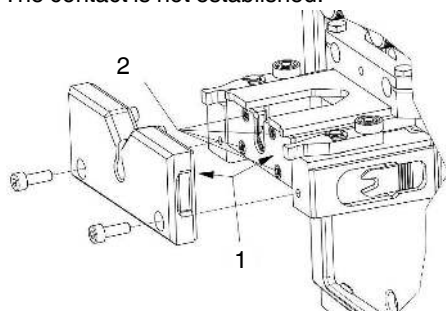

## 4.2 Cable not clamped

The cable slips through the clamping jaws during stripping.

### Possible causes

- The clamping jaws are dirty and must be cleaned.
- The clamping jaws are worn and must be replaced (see page 4-3).
- The cable is not suitable.

## 4.3 Blade will not cut

The blades do not cut correctly.

### Possible causes

- The correct parameters were not set.
- The blades are blunt and must be replaced (see page 4-3).
- The cable is not suitable.

## 4.4 Blade will not open

The blade no longer opens.



**WARNING: Risk of injury**

The blades are sharp. Make sure that you do not touch the cutting edge.

- Carefully slide the blades back with a flat object.  
The blades should snap back smoothly.
- If the blades cannot be pushed back smoothly, dismantle the blades using the same procedure as for blade replacement (see page 4-3).
- Remove any remaining insulation from the stripping area.



## 4.5 Replacing the blades and clamping jaws

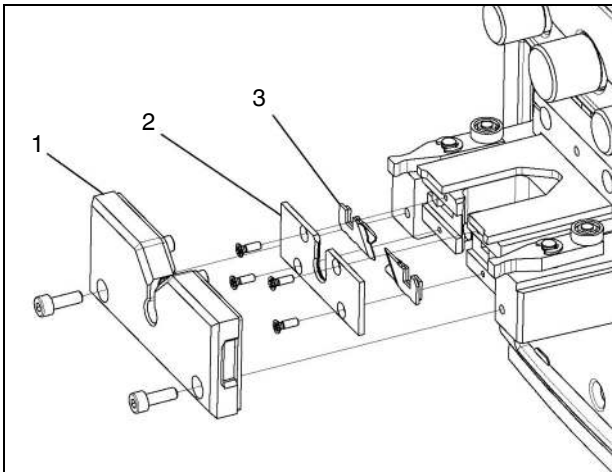

### Replacing the blades



**WARNING: Risk of injury**

Switch off the WF 1000 via the mains switch and disconnect the mains plug.



**WARNING: Risk of injury**

The blades are sharp. Make sure that you do not touch the cutting edge.

- Remove the clamping jaw cartridge (1).
- Remove the blade cover (2).
- Replace the blades (3).

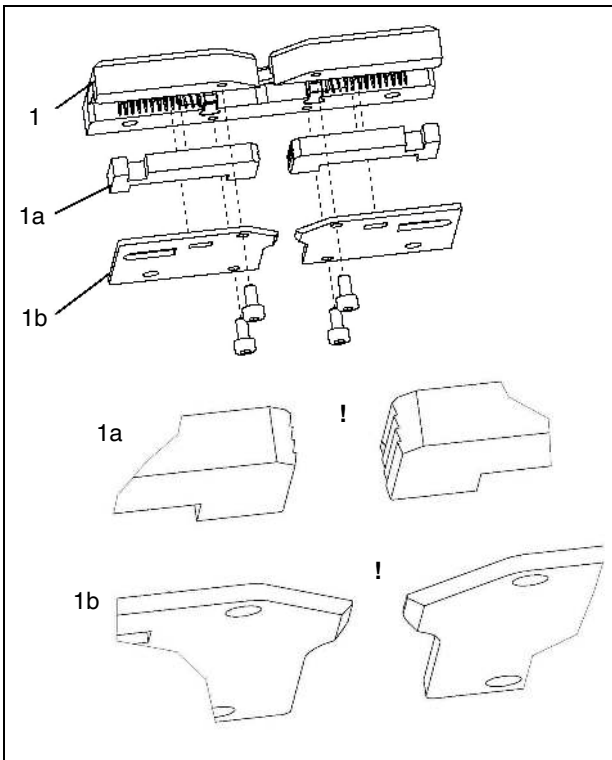

### Replacing the clamping jaws



**WARNING: Risk of injury**

Switch off the WF 1000 via the mains switch and disconnect the mains plug.

- Remove the covers (1b) from the clamping jaw cartridge (1).
- Replace the clamping jaws (1a).



**NOTE:** When assembling, make sure that the clamping jaws (1a) and covers (1b) are correctly positioned when installed.

- Fit the covers again.

## 4.6 Replacing the mains fuse

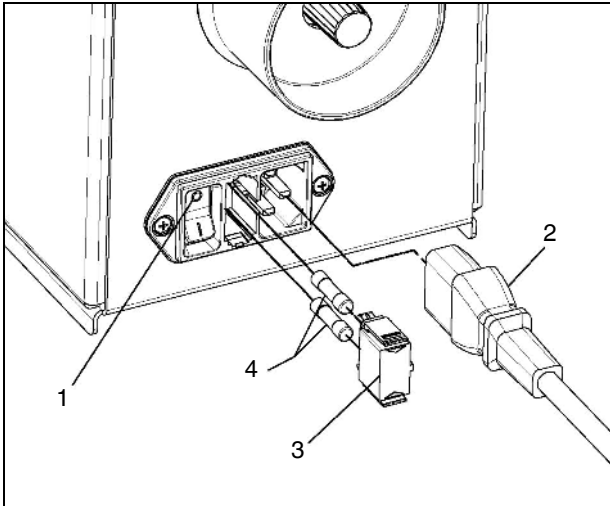

### Replacing the mains fuse

**WARNING: Risk of injury**

Switch off the WF 1000 via the mains switch and disconnect the mains plug.

- Switch off the WF 1000 via the mains switch (1) (press 0).
- Disconnect the mains plug (2).
- Remove the fuse holder (3).
- Check the mains fuses (4).
- Replace the faulty mains fuses:
  - 230 V - 1.25 A mains fuse, slow-blow
  - 115 V - 2.5 A mains fuse, slow-blow
- Push the fuse holder back in

**NOTE:** The fuse holder must snap into place.





# A Technical appendix

## A 1 Ordering data

### Stripping machine

Description	Type	Order No.	Pcs. / Pkt.
Stripping machine, 230 V version, for conductors and cables, solid and stranded 0.08 - 6 mm <sup>2</sup> (maximum Ø 6 mm), with integrated graphic display	WF 1000	1212149	1
Stripping machine, 120 V version, for conductors and cables, solid and stranded 0.08 - 6 mm <sup>2</sup> (maximum Ø 6 mm), with integrated graphic display	WF 1000 120V	1212258	1

### Replacement parts

Description	Type	Order No.	Pcs. / Pkt.
Stripping blade 	WF 1000/SB	1212279	1 set
Clamping jaws 	WF 1000/CJ	1212415	1 set
Start button 	WF 1000/TR	1212416	1 set
Receptacle tray 	WF 1000/COV	1212417	1 piece
Cable centering aid 		On request	
230 V – 1.25 A mains fuse, slow-blow	–	–	2 pieces
115 V – 2.5 A mains fuse, slow-blow	–	–	2 pieces

## A 2 Technical data

Technical data	
Mains connection	
WF 1000	230 V/50 Hz
WF 1000 120V	120 V/60 Hz
Power consumption	160 VA
Processing cross section	0.08 mm <sup>2</sup> ... 6 mm <sup>2</sup>
Outside diameter, maximum	6 mm
Stripping length	2 mm ... 20 mm
Partial removal length	2 mm ... 20 mm
Insertion length + stripping length	15 mm + x
Stripping blade	V-shaped
Stripping time/cycle	0.2 s ... 0.3 s
Counter	6-digit LCD, can be reset
Dimensions (W x H x D)	141 x 221 x 363 mm
Weight of basic device	9.5 kg

# A 3 Declaration of conformity



10-04410.00.01

**EG-Konformitätserklärung  
EC-Declaration of Conformity**

Hersteller / Manufacturer: **PHOENIX CONTACT GMBH & CO. KG**  
 Anschrift / Address: **Flachmarktstraße 8, D-32825 Blomberg, Germany**

Produktbezeichnung / Product description: **WF 1000**  
(Artikelbezeichnung / Article description, Artikel-Nr. / Article no.) **1212149**

Das vorstehend bezeichnete Produkt stimmt mit den wesentlichen Anforderungen der nachfolgenden Richtlinie(n) und deren Änderungsrichtlinien überein / The above mentioned product is in line with the essential requirements of the below directive(s) and their modification directive(s):

<b>2004/108/EC</b>	<b>EMV-Richtlinie (Elektromagnetische Verträglichkeit) Electromagnetic Compatibility Directive (EMC)</b>
<b>2006/42/EC</b>	<b>Maschinenrichtlinie Machinery Directive</b>
<b>2006/95/EC</b>	<b>Niederspannungs-Richtlinie (NSR) Low Voltage Directive (LVD)</b>

Für die Beurteilung der Übereinstimmung wurden folgende einschlägige Normen herangezogen:  
 For evaluation of the conformity following relevant standards were consulted:

EN ISO 12100-1:2003	EN ISO 12100-2:2003	EN ISO 13857:2008
EN 349:1993 + A1	EN 60204-1:2006	EN 61000-6-2:2005
EN 61000-6-3:2007		

Weitere Informationen (z. B. Dokumente, Prüfberichte, Einschränkungen, etc.) zur Konformitätsbewertung:  
 Additional information (for example documents, test reports, restrictions etc.,) of the conformity assessment:

Zertifikate einer benannten Stelle / Certificates by a notified body:  
 Anschrift / Address: \_\_\_\_\_  
 Referenz / Reference: \_\_\_\_\_  
 Anschrift / Address: \_\_\_\_\_  
 Referenz / Reference: \_\_\_\_\_

Die letzten beiden Ziffern des Jahres in dem die CE-Kennzeichnung angebracht wurde:  
 The last two figures of the year in which the CE marking was applied: 09  
(nur eintragen, bei der Niederspannungsrichtlinie / only to be entered on the low voltage directive)

Diese Erklärung gilt auch für die im Anhang aufgelisteten Produkte. (wenn angekreuzt)  
This declaration also applies for the products listed in the annex: (if marked with a cross)

Diese Erklärung bescheinigt die Übereinstimmung mit den wesentlichen Anforderungen der genannten Richtlinie(n), enthält jedoch keine Zusicherung von Eigenschaften. Die Sicherheits- und Einbauhinweise der mitgelieferten Produktdokumentation sind zu beachten.  
This declaration certifies the conformity with the essential requirements of the indicated directive(s), it does not, however, covenant any characteristics. The instructions for safety and installation of the enclosed product documentation have to be observed.

Blomberg, 2010-03-22

  
 Sandra Klocke  
 Business Unit Industrial Connection Technology  
 Head of Development Marking System & Service  
Responsible contact person

  
 Dirk Gönitzer  
 Business Unit Industrial Connection Technology  
 Vice President, Head of the Business Unit  
Technischer Leiter / authorized signatory

FS A-7-0037 / -08-  
10-04410.00.01.doc

Formblätterstatistik:  
Date of form establishment: 2009-11-10  
Formblättersteller:  
Form establisher: Corporate Technology

Blatt / Page 1 von / of 2



10-04410.00.01

**Anhang zur EG-Konformitätserklärung  
Annex on EC Declaration of Conformity  
vom / dated 22.03.2010**

Produktbezeichnung / Product description: **WF 1000**  
(Artikelbezeichnung / Article description, Artikel-Nr. / Article no.) **1212149**

Die Konformität mit den wesentlichen Anforderungen der Richtlinie(n) wird auch für folgende Produkte bescheinigt:  
 The conformity with the essential requirements of the directive(s) is also certified by the declaration for following products:

Artikel-Nr. / Article no.	Artikelbezeichnung / Article description
1212258	WF 1000 120V

10-04410.00.01.doc

Blatt / Page 2 von / of 2

PHOENIX CONTACT GmbH & Co. KG, Flachmarktstraße 8, D-32825 Blomberg, Germany

WF 1000

WF 1000-120 V

The above-mentioned products are in conformity with the most important requirements of the following directives and their amending directives.

- 2004/108/EC      EMC Directive (Electromagnetic Compatibility)
- 2006/42/EC      Machinery Directive
- 2006/95/EC      Low-Voltage Directive (LVD)

The following pertinent standards were consulted for evaluating the conformity:

- EN ISO 12100-1:2003      EN ISO 12100-2:2003      EN ISO 13857:2008
- EN 349:1993 + A1      EN 60204-1:2006      EN 61000-6-2:2005
- EN 61000-6-3:2007