

PART NO.	ENGINEERING NO.	LENGTH
1300620308	114032K27M030G	3M
1300620309	114032K27M060G	6M
1300620310	114032K27M090G	9M

CABLE LENGTH TOLERANCES	
>.3M [1FT]:	+19mm-0 [+.75in-0]
.3 - .9M [1 - 3FT]:	+44.5mm-0 [+1.75in-0]
.9 - 1.8M [3 - 6FT]:	+55.6mm-0 [+2.19in-0]
1.8 - 3.7M [6 - 12FT]:	+88.9mm-0 [+3.50in-0]
3.7 - 7.3M [12 - 24FT]:	+165.1mm-0 [+6.50in-0]
7.3-14.6M [24 - 48FT]:	+317.5mm-0 [+12.50in-0]
14.6 - 30.5M [48-100FT]:	+622.3mm-0 [+24.50in-0]
OVER 30M [100FT]:	+2% OF FINISHED LENGTH

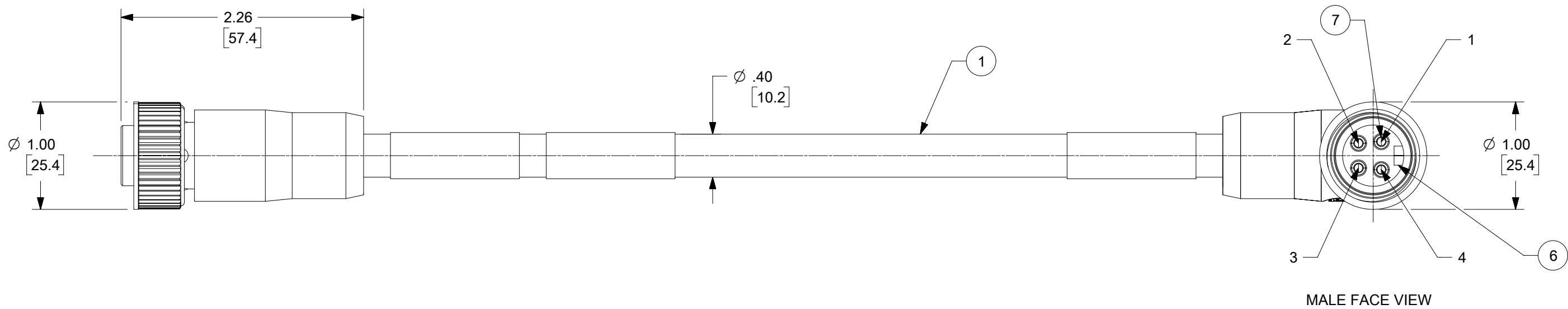
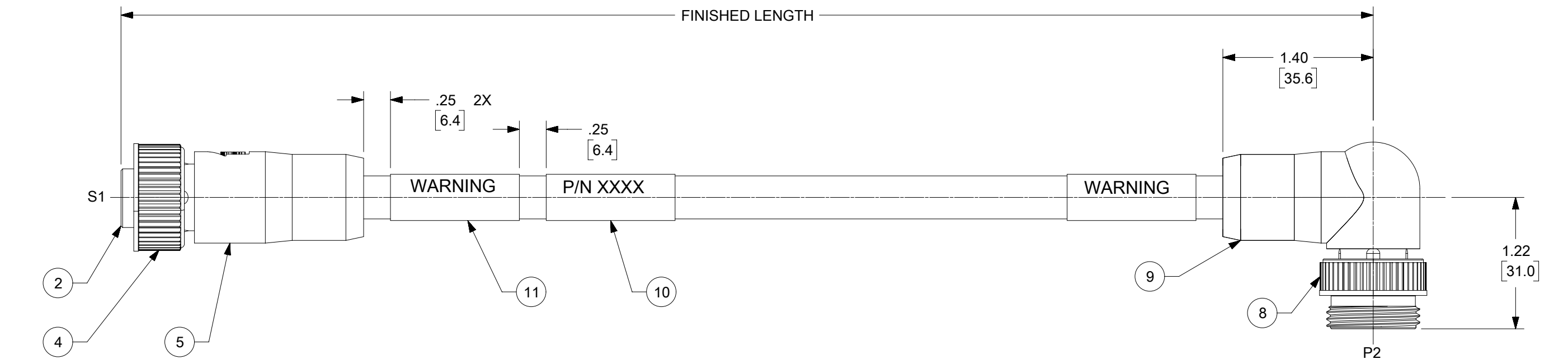
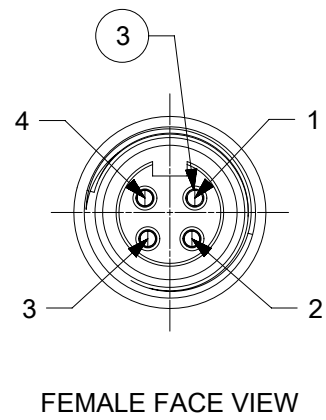

- NOTES:
1. MATERIAL: AS NOTED
 2. FINISHES: AS NOTED
 3. WRAP LABEL IS MARKED WITH P/N, DATE CODE VOLTAGE AND AMPERAGE
 4. ELECTRICAL DATA:
VOLTAGE: 600V
CURRENT: 15A
 5. PROTECTION: IP67 (WHEN MATED)
 6. COUPLING THREAD: 7/8-16
 7. PACKAGING: CORD ASSEMBLIES ARE BAGGED SEPERATELY WITH BARCODE LABEL
 8. DIMENSIONS SHOWN ARE FOR REFERENCE UNLESS NOTED OTHERWISE
 9. UL LISTED FILE E258922 (PENDING)

114032K27M030G

M005 = 0.5 METERS
M030 = 3 METERS
M100 = 10 METERS

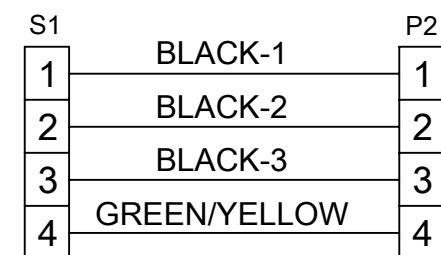

WIRE DIAGRAM

ITEM	DESCRIPTION	MATERIAL	FINISH
11	WARNING LABEL	VINYL	BLACK/ORANGE
10	WRAP LABEL	VINYL	BLACK/YELLOW
9	90 DEG O-MOLD	PVC	BLACK
8	MALE COUPLING NUT	ZINC DIE-CAST	BLACK
7	CONTACT PIN	Cu ALLOY	GOLD PLATED
6	MALE INSERT	PVC	BLACK
5	STRAIGHT O-MOLD	PVC	BLACK
4	FEMALE COUPLING NUT	ZINC DIE-CAST	BLACK
3	CONTACT SOCKET	Cu ALLOY	GOLD PLATED
2	FEMALE INSERT	PVC	BLACK
1	CABLE, 14/4 TC-ER, HI FLEX	TPE JACKET	BLACK

SYMBOLS		THIS DRAWING CONTAINS INFORMATION THAT IS PROPRIETARY TO MOLEX ELECTRONIC TECHNOLOGIES, LLC AND SHOULD NOT BE USED WITHOUT WRITTEN PERMISSION	
▽ = 0	HYBRID	DIMENSION UNITS: 1:1	SCALE: 1:1
▽ = 0	GENERAL TOLERANCES (UNLESS SPECIFIED)	CURRENT REV DESC: RELEASED	
▽ = 0	ANGULAR TOL ± °	EC NO: 175204	
▽ = 0	4 PLACES ±	DRWN: RSTONE 2018/04/18	
▽ = 0	3 PLACES ±	CHK'D: MZIELINSKI 2018/04/24	
▽ = 0	2 PLACES ±	APPR: BWOODMAN 2018/04/27	
▽ = 0	1 PLACE ±	INITIAL REVISION:	
▽ = 0	0 PLACES ±	DRWN: RSTONE 2018/04/18	
▽ = 0	DRAFT WHERE APPLICABLE MUST REMAIN WITHIN DIMENSIONS	APPR: BWOODMAN 2018/04/27	
▽ = 0	THIRD ANGLE PROJECTION	DRAWING: C-SIZE	SERIES: 130062
		MATERIAL NUMBER: SEE P/N CHART	CUSTOMER: 1300620308
		DOCUMENT NUMBER: 1300620308	DOC TYPE: PSD
		DOC PART: 000	REVISION: A
		PRODUCT CUSTOMER DRAWING	
		SHEET NUMBER: 1 OF 1	