

ADVANTECH

ADVANTECH

DRAM Memory Module

Portfolio Introduction

PAPS Product Management
Q1 / 2016

PART I.

**ADVANTECH QUALIFIED DIMM
(AQD)**

ADVANTECH QUALIFIED DIMM

Built to Last ---

The toughest memory module for rigorous applications



Best Quality Component

■ Brand DRAM

AQD only uses the **BEST** quality and most durable components for industrial applications. This represents the top 15% of total wafer output.

SELLING PROPOSITION



QUALITY



RELIABILITY

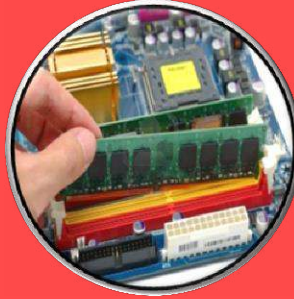

COMPATIBILITY



LONGEVITY



**LIFE-TIME
WARRANTY**





100% Module On Board Testing

Shock & Vibration Test

Chamber Test

Functional Test

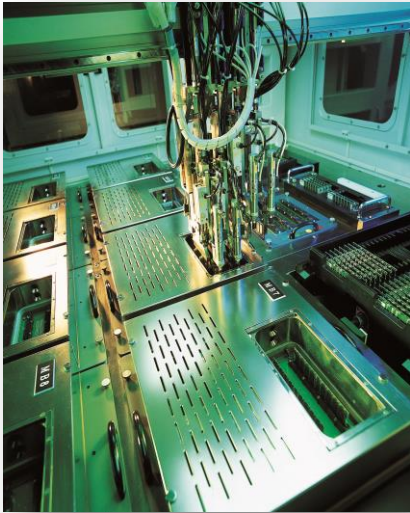

Check & Compare

Both Teams Cross Compare Testing Results to Ensure M/B & Memory Compatibility

Memory Compatibility Testing Result

Part No	9603-1G1068N-AP	9603-1G1068N-TR	9603-2C1068N-AP	9603-2C1068N-TR	9603-4C1068N-AP	9603-1G1333N-AP	9603-1G1333N-AP1	9603-1G1333N-SA	9603-1G1333N-TR	9603-1G1333N-TR1	9603-2C1333N-AP
ARK-DS302-S6A1E											
ARK-DS302-S6A1E											
ARK-DS302-S6A2E											
ARK-DS302-S6A2E											
ARK-DS350-00A1E											
ARK-DS350-00B1E											
ARK-DS350-U0A1E											
ARK-DS350-U2A1E											
ARK-DS350-U7B1E											
ARK-DS350-USB1E											
ASMB-310-00A1E											
ASMB-310IR-00A1E											
ASMB-781G2-00A1E	x	x	x	x	x	x	x	x	x	x	x
ASMB-781G4-00A1E	x	x	x	x	x	x	x	x	x	x	x
ASMB-920-00A1E											
ASMB-920IR-00A1E											
FWA-3210A											
FWA-3210B											
FWA-6500BE											

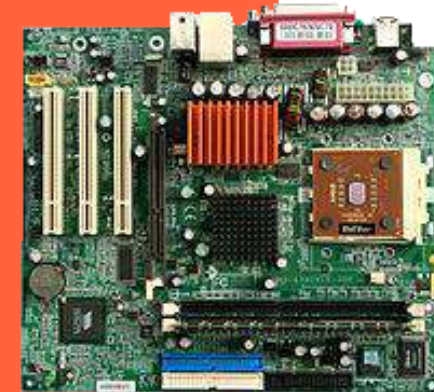

Motherboard Team DOA Testing Result

☐ Locked BOM

- IC Spec
- PCB Layout

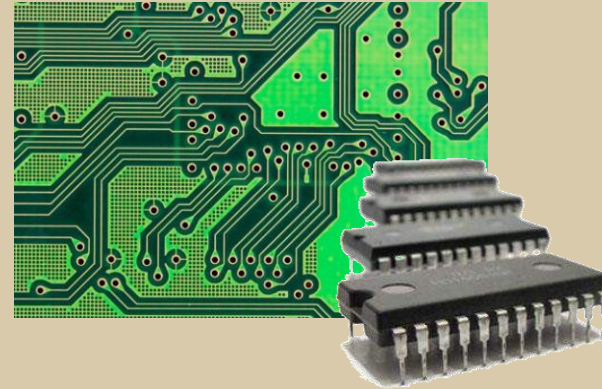

☐ Minimum 3 Years Longevity



Quality Assurance

Rigorous Reliability
Tests

Cross-Checked
Compatibility

Longevity

Life-Time Warranty



**Every ADVATECH QUALIFIED
DIMM (AQD) is back up by
Lifetime Warranty**



Small Things Matter

For better durability all AQD DRAM applies IPC-2221, using **30u Golden** plated connector to ensure DRAM's stability in any given circumstances. (Est. Running Change Q1 / 2015)



AQD Product Portfolio



Unbuffered DIMM

- General IPC Applications

- ❑ DDR3: 1GB, 2GB, 4GB & 8GB
- ❑ DDR4: 4GB, 8GB, 16GB *(New)*

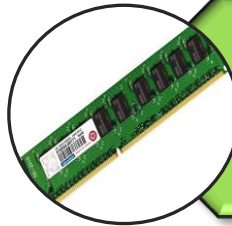

ECC Unbuffered DIMM

- Improve System Productivity & Efficiency

- ❑ DDR3: 2GB, 4GB & 8GB
- ❑ DDR4: 4GB, 8GB, 16GB *(New)*

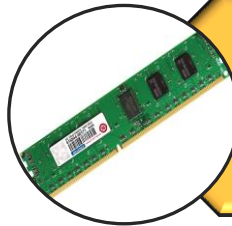

Registered DIMM

- Providing The Best Solution for Capacity and Performance Requirement

- ❑ DDR3: 4GB, 8GB & 16GB
- ❑ DDR4: 4GB, 8GB & 16GB

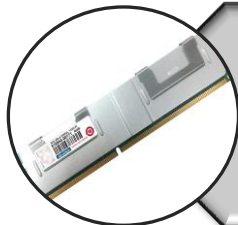

Load Reduce DIMM

- Providing the biggest capacity per server with the lowest energy costs

- ❑ DDR3: 32GB



Product Roadmap
Q1 2016

AQD Naming Convention

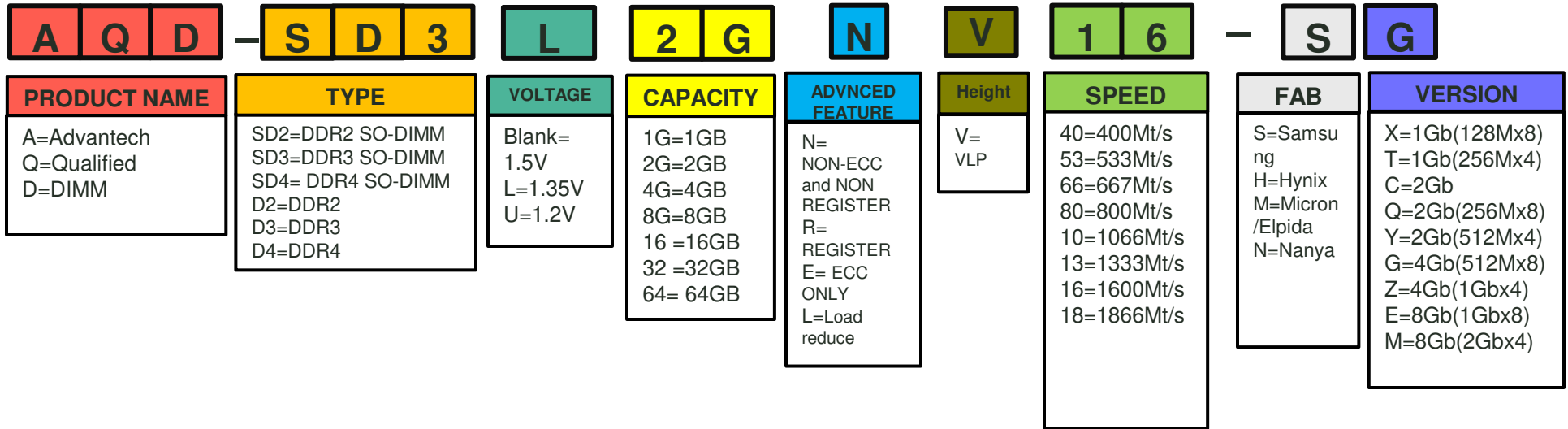

Color / Symbol Key

Available

Planning

Phasing-out



New



Focus Product

ECC ECC

B Fully Buffered

R Registered

LR Load Reduce



Wide Temperature



Very Low Profile



Low Voltage



Ultra Low Voltage

AQD DDR2 & DDR3 Memory Modules Portfolio

□ Unbuffered DIMM

		800	1333		1600		
		SHORT	LONG	SHORT	LONG		SHORT
		Non-VLP	Non-VLP	Non-VLP	VLP	Non-VLP	Non-VLP
U-DIMM	1GB (128X8)	AQD-SD21GN80-SX	AQD-D31GN13-SX	AQD-SD31GN13-SX			
	1GB (128X16)					AQD-D31GN16-HC AQD-D3L1GN16-HC	AQD-SD31GN16-HC AQD-SD3L1GN16-HC
	2GB (256MX8)				AQD-D3L2GNV16-SQ (New)	AQD-D3L2GN16-SQ AQD-D3L2GN16-HQ	AQD-SD3L2GN16-SQ AQD-SD3L2GN16-HQ
	4GB (256MX8)					AQD-D3L4GN16-MQ AQD-D3L4GN16-SQ	AQD-SD3L4GN16-MQ AQD-SD3L4GN16-SQ
	4GB (512MX8)				AQD-D3L4GNV16-SG (New)	AQD-D3L4GN16-SG AQD-D3L4GN16-HG AQD-D3L4GN16-MG	AQD-SD3L4GN16-SG AQD-SD3L4GN16-HG AQD-SD3L4GN16-MG
	8GB (512MX8)				AQD-D3L8GNV16-SG (New)	AQD-D3L8GN16-SG AQD-D3L8GN16-HG AQD-D3L8GN16-MG	AQD-SD3L8GN16-SG AQD-SD3L8GN16-HG AQD-SD3L8GN16-MG

AQD DDR3 Memory Modules Portfolio

- ECC Unbuffered DIMM*
- Registered DIMM*
- Load Reduce DIMM*

		1333		1600		
		LONG	SHORT	LONG		SHORT
		Non-VLP	Non-VLP	VLP	Non-VLP	Non-VLP
ECC U-DIMM	2GB (256MX8)				AQD-D3L2GE16-SQ	
	4GB (512MX8)				AQD-D3L4GE16-SG	AQD-SD3L4GE16-SG AQD-SD3L4GE16-MG
	8GB (512MX8)				AQD-D3L8GE16-SG	AQD-SD3L8GE16-SG AQD-SD3L8GE16-MG
R-DIMM	4GB (512MX8)				AQD-D3L4GR16-SG	
	8GB (512MX8)	AQD-D3L8GR13-SG		AQD-D38GRV16-SG AQD-D3L8GRV16-SG	AQD-D3L8GR16-SG	
	16GB (2Gbx4)			AQD-D316RV16-SM AQD-D3L16RV16-SM	AQD-D3L16R16-SM	
LOAD REDUCE	32GB (2Gbx4)	AQD-D3L32L13-SM				

DDR3 DIMM

1GB

AQD-D31GN13-SX

240PIN, 1333Mt/s, 128Mx8, 1.181" Height, Samsung, 1.5V

AQD-D31GN16-HC

240PIN, 1600Mt/s, 128Mx16, 1.181" Height, Hynix, 1.5V

AQD-D3L1GN16-HC

240PIN, 1600Mt/s, 128Mx16, 1.181" Height, Hynix, 1.35V

LV

AQD-D3L2GN16-SQ

240PIN, 1600Mt/s, 256Mx8, 1.181" Height, Samsung Chips 1.35V



LV

AQD-D3L2GN16-HQ

240PIN, 1600Mt/s, 256Mx8, 1.181" Height, Hynix Chips 1.35V

LV

AQD-D3L2GNV16-SQ

240PIN, 1600Mt/s, 256Mx8, 0.74" Height, Samsung Chips 1.35V



VLP LV

2GB

Q1/2016

Q2/2016

Q3/2016

Q4/2016

Q1/2016

DDR3 DIMM

4GB

8GB

AQD-D3L4GN16-SG

240PIN, 1600Mt/s, 512Mx8, 1.181" Height, Samsung Chips 1.35V

AQD-D3L4GN16-HG

240PIN, 1600Mt/s, 512Mx8, 1.181" Height, Hynix Chips 1.35V

AQD-D3L4GN16-SQ

240PIN, 1600Mt/s, 256Mx8, 1.181" Height, Samsung 1.35V

AQD-D3L4GN16-MG

240PIN, 1600Mt/s, 512Mx8, 1.181" Height, Micron Chips 1.35V

AQD-D3L4GN16-MQ

240PIN, 1600Mt/s, 256Mx8, 1.181" Height, Micron Chips 1.35V

AQD-D3L4GNV16-SQ

240PIN, 1600Mt/s, 256Mx8, 0.74" Height, Samsung Chips 1.35V

AQD-D3L8GN16-SG

240PIN, 1600Mt/s, 512Mx8, 1.181" Height, Samsung Chips 1.35V

AQD-D3L8GN16-HG

240PIN, 1600Mt/s, 512Mx8, 1.181" Height, Hynix Chips 1.35V

AQD-D3L8GN16-MG

240PIN, 1600Mt/s, 512Mx8, 1.181" Height, Micron Chips 1.35V

AQD-D3L8GNV16-SQ

240PIN, 1600Mt/s, 256Mx8, 0.74" Height, Samsung Chips 1.35V

Q1/2016

Q2/2016

Q3/2016

Q4/2016



ECC



Fully Buffered



Registered



Load Reduce



Wide Temperature



Very Low Profile



Low Voltage



Ultra Low Voltage

DDR3 SO-DIMM

1GB

AQD-SD31GN13-SX



204PIN, 1333Mt/s, 128Mx8, 1.181" Height, Samsung Chips 1.5V

AQD-SD31GN16-HC

204PIN, 1600Mt/s, 128Mx16 1.181" Height, Hynix Chips 1.5V

AQD-SD3L1GN16-HC



204PIN, 1600Mt/s, 128Mx16 1.181" Height, Hynix Chips 1.35V

2GB

AQD-SD3L2GN16-SQ



204PIN, 1600Mt/s, 256Mx8, 1.181" Height, Samsung Chips 1.35V



AQD-SD3L2GN16-HQ



204PIN, 1600Mt/s, 256Mx8, 1.181" Height, Hynix, Chips 1.35V

4GB

AQD-SD3L4GN16-SG



204PIN, 1600Mt/s, 512Mx8, 1.181" Height, Samsung Chips 1.35V



AQD-SD3L4GN16-HG



204PIN, 1600s, 512Mx8, 1.181" Height, Hynix Chips 1.35V

AQD-SD3L4GN16-MG



204PIN, 1600s, 512Mx8, 1.181" Height, Micron Chips 1.35V

AQD-SD3L4GN16-SQ



204PIN, 1600s, 256Mx8, 1.181" Height, Samsung Chips 1.35V

AQD-SD3L4GN16-MQ



204PIN, 1600s, 256Mx8, 1.181" Height, Micron Chips 1.35V

8GB

AQD-SD3L8GN16-SG



204PIN, 1600Mt/s, 512Mx8, 1.181" Height, Samsung, Chips 1.35V



AQD-SD3L8GN16-HG



204PIN, 1600Mt/s, 512Mx8, 1.181" Height, Hynix, Chips 1.35V

AQD-SD3L8GN16-MG



204PIN, 1600Mt/s, 512Mx8, 1.181" Height, Micron, Chips 1.35V

DDR3 DIMM – Advanced Feature

ECC

2GB

AQD-D3L2GE16-SQ

240 PIN, 1600Mt/s, 256Mx8,1R 1.181" Height, Samsung, 1.35V

ECC LV

4GB

AQD-D3L4GE16-SG

240 PIN, 1600Mt/s, 512 Mx8,1R 1.181" Height, Samsung, 1.35V

ECC LV

8GB

AQD-D3L8GE16-SG

240PIN, 1600Mt/s, 512Mx8,2R 1.181" Height, Samsung, 1.35V

ECC LV

Q1/2016

Q2/2016

Q3/2016

Q4/2016

DDR3 SO-DIMM – Advanced Feature

ECC

2GB

AQD-SD3L2GE16-MG

240 PIN, 1600Mt/s, 256 Mx8, 1R 1.181" Height, Micron, 1.35V

ECC **LV**

4GB

AQD-SD3L4GE16-SG

204 PIN, 1600Mt/s, 512 Mx8, 1R 1.181" Height, Samsung, 1.35V

ECC **LV**

AQD-SD3L4GE16-MG

204 PIN, 1600Mt/s, 512 Mx8, 1R 1.181" Height, Micron, 1.35V

ECC **LV**

8GB

AQD-SD3L8GE16-SG

204PIN, 1600Mt/s, 512Mx8, 2R 1.181" Height, Samsung, 1.35V

ECC **LV**

AQD-SD3L8GE16-MG

204PIN, 1600Mt/s, 512Mx8, 2R 1.181" Height, Micron, 1.35V

ECC **LV**

Q1/2016

Q2/2016

Q3/2016

Q4/2016

DDR3 DIMM – Advanced Feature

Registered

4GB

AQD-D3L4GR16-SG

240PIN, 1600 Mt/s, 512 Mx8 1R, 1.18" Height, Samsung Chips 1.35V



8GB

AQD-D3L8GR13-SG

240PIN, 1333 Mt/s, 512 Mx8 2R, 1.18" Height, Samsung Chips 1.35V



AQD-D3L8GR16-SG

240PIN, 1600 Mt/s, 512 Mx8 2R, 1.18" Height, Samsung Chips 1.35V



AQD-D38GRV16-SG

240PIN, 1600 Mt/s, 512 Mx8 2R, 1.18" Height, Samsung Chips 1.35V



AQD-D3L8GRV16-SG

240PIN, 1600 Mt/s, 512 Mx8 2R, VLP 0.74" Height, Samsung Chips 1.35V



16GB

AQD-D3L16R16-SM

240PIN, 1600 Mt/s, 1Gx4 2R, 0.74" Height, Samsung, Chips 1.35V



AQD-D316RV16-SM

240PIN, 1600 Mt/s, 2Gx4 2R, 0.74" Height, Samsung, Chips 1.35V



AQD-D3L16RV16-SM

240PIN, 1600 Mt/s, 2Gx4 2R, 0.74" Height, Samsung, Chips 1.35V



Q1/2016

Q2/2016

Q3/2016

Q4/2016

Q1/2016

Enabling an Intelligent Planet

ADVANTECH

DDR3 SO-DIMM – Advanced Feature Load Reduce

32GB

AQD-D3L32L13-SM

240PIN, 1333 Mt/s, 2Gbx4 ,4R, 1.810" Height, Samsung, Chips 1.5V

LR

Q1/2016

Q2/2016

Q3/2016

Q4/2016

DDR4 Roadmap

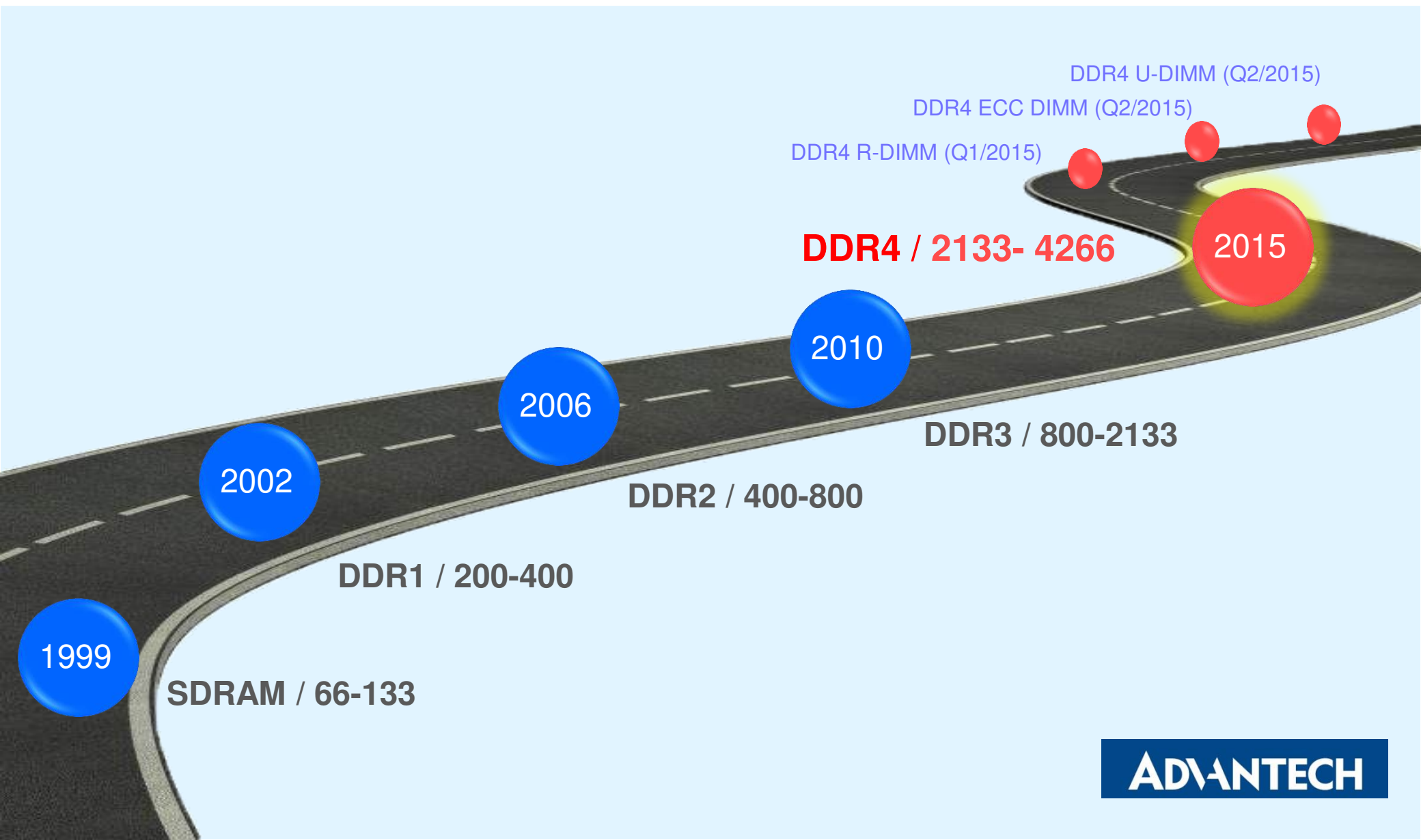

DDR4 Market Penetration 2015

(DDR3 v.s. DDR4)

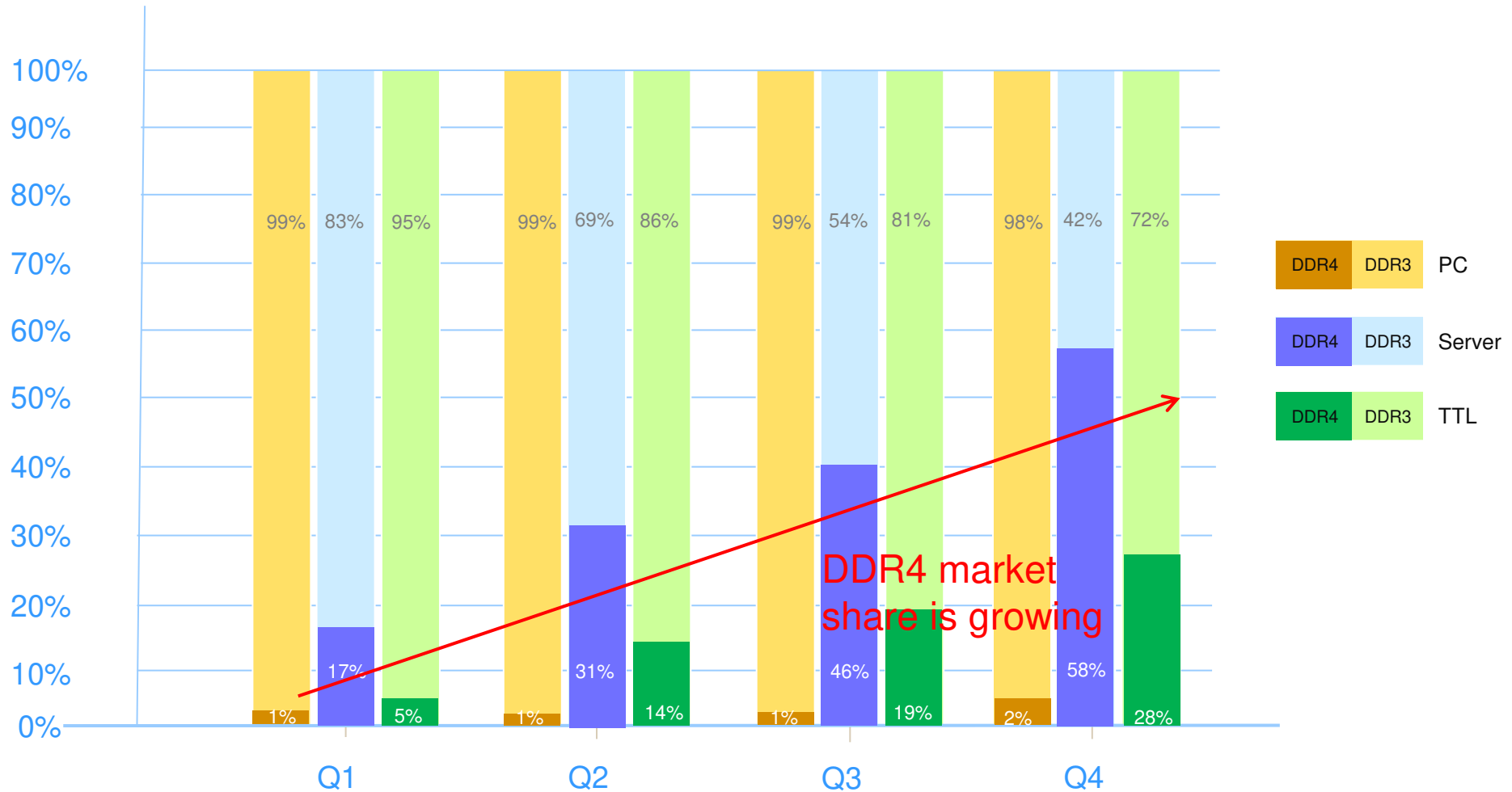

AQD DDR4 Memory Modules Portfolio

		2133		
			LONG	SHORT
		VLP	Non-VLP	Non-VLP
U-DIMM	4GB (512Mx8)		AQD-D4U4GN21-SG	AQD-SD4U4GN21-SG
	8GB (512Mx8)		AQD-D4U8GN21-SG	AQD-SD4U8GN21-SG
	16GB (1Gbx8)		AQD-D4U16N21-SE (New)	AQD-SD4U16N21-SE (New)
ECC U-DIMM	4GB (512Mx8)		AQD-D4U4GE21-SG	AQD-SD4U4GE21-SG
	8GB (512Mx8)		AQD-D4U8GE21-SG	AQD-SD4U8GE21-SG
	16GB (1Gbx8)		AQD-D4U16E21-SE (New)	AQD-SD4U16E21-SE (New)
R-DIMM	4GB (512Mx8)		AQD-D4U4GR21-HG AQD-D4U4GR21-SG (Coming Soon)	
	8GB (512Mx8)	AQD-D4U8GRV21-SG (New)	AQD-D4U8GR21-SG (Coming Soon)	
	8GB (1Gbx4)		AQD-D4U8GR21-HZ	
	16GB (1Gbx4)		AQD-D4U16R21-HZ	
	16GB (1Gbx8)		AQD-D4U16R21-SE (New)	
	16GB (2Gbx4)	AQD-D4U16RV21-SM (New)		

DDR4 DIMM

4GB

AQD-D4U4GN21-SG

288PIN, 2133Mt/s, 512Mx8 31.25mm/1.23" Height, Samsung Chips 1.2V

UV

8GB

AQD-D4U8GN21-SG

288PIN, 2133Mt/s, 512Mx8, 31.24mm/1.23" Height, Samsung Chips 1.2V

UV

16GB

AQD-D4U16N21-SE

288PIN, 2133Mt/s, 1Gbx8, 31.24mm/1.23" Height, Samsung Chips 1.2V

UV



DDR4 SO-DIMM

4GB

AQD-SD4U4GN21-SG

260PIN, 2133Mt/s, 512Mx8 31.25mm/1.23" Height, Samsung Chips 1.2V

UV

8GB

AQD-SD4U8GN21-SG

260PIN, 2133Mt/s, 512Mx8, 31.24mm/1.23" Height, Samsung Chips 1.2V

UV

16GB

AQD-SD4U16N21-SE

260PIN, 2133Mt/s, 1Gbx8, 31.24mm/1.23" Height, Samsung Chips 1.2V

UV



Q1/2016

Q2/2016

Q3/2016

Q4/2016

Q1/2016

Enabling an Intelligent Planet

ADVANTECH

DDR4 DIMM

4GB

AQD-D4U4GN21-HG

288PIN, 2133Mt/s, 512Mx8 31.25mm/1.23" Height, Hynix Chips 1.2V

NEW

UV

8GB

AQD-D4U8GN21-HG

288PIN, 2133Mt/s, 512Mx8, 31.24mm/1.23" Height, Hynix Chips 1.2V

NEW

UV

DDR4 SO-DIMM

4GB

AQD-SD4U4GN21-HG

260PIN, 2133Mt/s, 512Mx8 31.25mm/1.23" Height, Hynix Chips 1.2V

NEW

UV

8GB

AQD-SD4U8GN21-HG

260PIN, 2133Mt/s, 512Mx8, 31.24mm/1.23" Height, Hynix Chips 1.2V

NEW

UV

Q1/2016

Q2/2016

Q3/2016

Q4/2016

Q1/2016

Enabling an Intelligent Planet

ADVANTECH

DDR4 DIMM – Advanced Feature

ECC

4GB

AQD-D4U4GE21-SG

288PIN, 2133Mt/s, 512Mx8 31.25mm/1.23" Height, Samsung Chips 1.2V

UV ECC

8GB

AQD-D4U8GE21-SG

288PIN, 2133Mt/s, 512Mx8 31.25mm/1.23" Height, Samsung Chips 1.2V

UV ECC

16GB

AQD-D4U16GE21-SE

288PIN, 2133Mt/s, 1Gbx8, 31.25mm/1.23" Height, Samsung Chips 1.2V

UV ECC

DDR4 SO-DIMM – Advanced Feature

ECC

4GB

AQD-SD4U4GE21-SG

260PIN, 2133Mt/s, 512Mx8 31.25mm/1.23" Height, Samsung Chips 1.2V

UV ECC

8GB

AQD-SD4U8GE21-SG

260PIN, 2133Mt/s, 512Mx8, 2R 21.25MM/1.23" Height, Samsung Chip 1.2V

UV ECC

16GB

AQD-SD4U16GE21-SE

260PIN, 2133Mt/s, 1Gbx8, 2R 21.25MM/1.23" Height, Samsung Chip 1.2V

UV ECC

Q1/2016

Q2/2016

Q3/2016

Q4/2016

Q1/2016

Enabling an Intelligent Planet

ADVANTECH

DDR4 DIMM – Advanced Feature

Registered

4GB

AQD-D4U4GR21-HG

288PIN, 2133 Mt/s, 512 Mx8 1R, 1.23" Height, Hynix Chips 1.2V



AQD-D4U4GR21-SG

288PIN, 2133 Mt/s, 512 Mx8 1R, 1.23" Height, Samsung Chips 1.2V



8GB

AQD-D4U8GR21-HZ

288PIN, 2133 Mt/s, 1Gbx4 1R, 1.23" Height, Hynix Chips 1.2V



AQD-D4U8GR21-SG

288PIN, 2133 Mt/s, 512 Mx8 2R, 1.23" Height, Samsung Chips 1.2V



AQD-D4U8GRV21-SG

288PIN, 2133 Mt/s, 2Gbx4 2R, 0.74" Height, Samsung Chips 1.2V



16GB

AQD-D4U16R21-HZ

288PIN, 2133 Mt/s, 1Gbx4 2R, 1.23" Height, Hynix Chips 1.2V



AQD-D4U16R21-SE

288PIN, 2133 Mt/s, 1Gbx4 2R, 1.23" Height, Samsung Chips 1.2V



AQD-D4U16RV21-SM

288PIN, 2133 Mt/s, 2Gbx4 2R, 0.74" Height, Samsung Chips 1.2V



Q1/2016

Q2/2016

Q3/2016

Q4/2016

Q1/2016

Enabling an Intelligent Planet

ADVANTECH

PART II,

96 PARTS MEMORY MODULE

96 DRAM Naming Convention

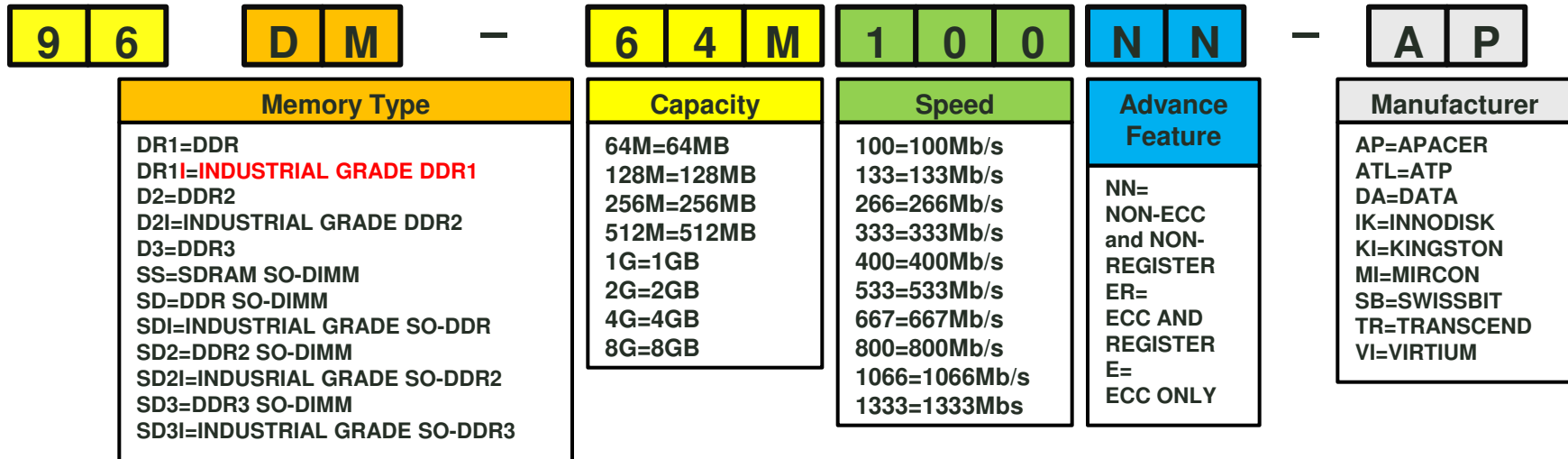

Color / Symbol Key



DDR2 DIMM

Available Phasing-out Planning
ECC ECC **B** Fully Buffered **R** Registered **LR** Load Reduce
LV Low Voltage **VLP** Very Low Profile **W** Wide Temperature
F Focus Product **NEW** New

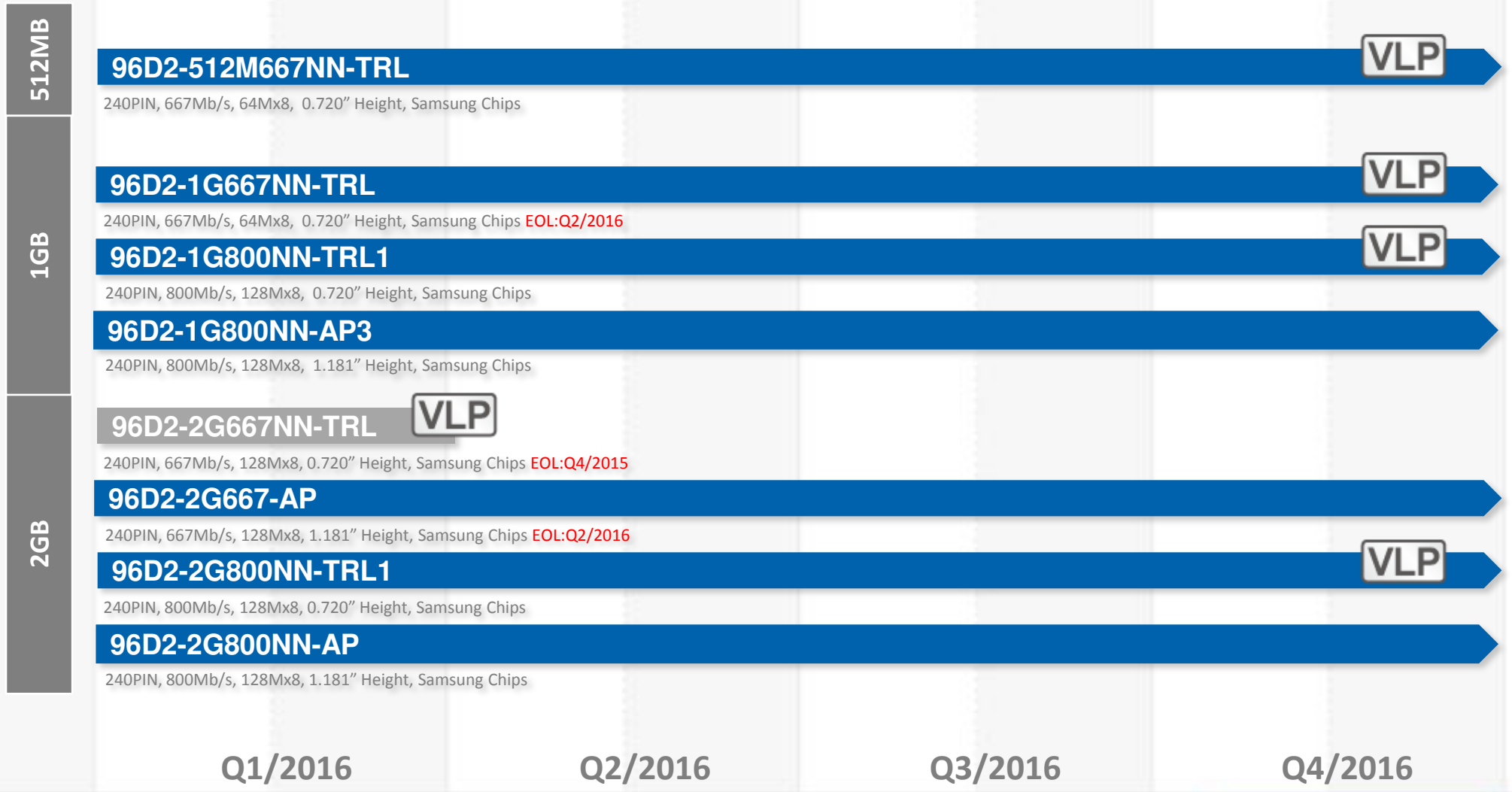

Q1/2016

Q2/2016

Q3/2016

Q4/2016

Q1/2016

DDR2 DIMM- Advanced Feature

Available Phasing-out Planning

ECC ECC B Fully Buffered R Registered LR Load Reduce

LV Low Voltage VLP Very Low Profile Wide Temperature

F Focus Product NEW New

ECC

2GB

96D2-2G800E-AP1

ECC

240PIN, 800Mb/s, 128Mx8, 1.181" Height, Samsung Chips

96D2-2G800E-TR1

ECC

240PIN, 800Mb/s, 128Mx8, 1.181" Height, Samsung Chips

Registered

1GB

96D2-1G400ER-TR

R

240PIN, 400Mb/s, 64Mx8, 1.181" Height, Samsung Chips

Q1/2016

Q2/2016

Q3/2016

Q4/2016

Q1/2016

Enabling an Intelligent Planet

ADVANTECH

DDR2 SO-DIMM

Available Phasing-out Planning

ECC ECC B Fully Buffered R Registered LR Load Reduce

LV Low Voltage VLP Very Low Profile W Wide Temperature

F Focus Product NEW New

512MB

96SD2-512M667NN-TR

200PIN, 667Mb/s, 64Mx8, 1.181" Height, Samsung Chips

1GB

96SD2-1G667NN-TR

200PIN, 667Mb/s, 128Mx8, 1.181" Height, Samsung Chips EOL: Q3/2016

96SD2-1G800NN-AP3

200PIN, 800Mb/s, 128Mx8, 1.181" Height, Samsung Chips

96SD2-1G800NN-TR1

200PIN, 800Mb/s, 128Mx8, 1.181" Height, Samsung Chips

2GB

96SD2-2G667NN-TR1

200PIN, 667Mb/s, 128Mx8, 1.181" Height, Samsung Chips EOL: Q3/2016

96SD2-2G800NN-TR1

200PIN, 800Mb/s, 128Mx8, 1.181" Height, Samsung Chips

96SD2-2G800NN-AP2

200PIN, 800Mb/s, 128Mx8, 1.181" Height, Samsung Chips

Q1/2016

Q2/2016

Q3/2016

Q4/2016

Q1/2016

Enabling an Intelligent Planet

ADVANTECH

DDR3 DIMM

Available Phasing-out Planning
ECC ECC B Fully Buffered R Registered LR Load Reduce
LV Low Voltage VLP Very Low Profile ⚡ Wide Temperature
F Focus Product NEW New

1GB

96D3-1G1333NN-TR1

240PIN, 1333Mb/s, 128Mx8, 1.181" Height, Samsung Chips

96D3-2G1066NN-TR

240PIN, 1066Mb/s, 128Mx8, 1.181" Height, Samsung Chips **EOL:Q3/2016**

96D3-2G1333NN-AP1

240PIN, 1333Mb/s, 256Mx8, 1.181" Height, Hynix Chips **EOL:Q4/2016**

96D3-2G1333NN-TR2

240PIN, 1333Mb/s, 128Mx8, 1.181" Height, Samsung Chips **EOL:Q3/2016**

96D3-2G1600NN-APL

240PIN, 1600Mb/s, 256Mx8, 0.740" Height, Hynix Chips

VLP

96D3-2G1600NN-TRL

240PIN, 1600Mb/s, 256Mx8, 0.74" Height, Samsung Chips

VLP

96D3-2G1600NN-TR

240PIN, 1600Mb/s, 256Mx8, 1.181" Height, MICRON Chips **EOL:Q4/2015**

Q1/2016

Q2/2016

Q3/2016

Q4/2016

2GB

Q1/2016

Enabling an Intelligent Planet

ADVANTECH

DDR3 DIMM

Available Phasing-out Planning
ECC ECC **B** Fully Buffered **R** Registered **LR** Load Reduce
LV Low Voltage **VLP** Very Low Profile **W** Wide Temperature
F Focus Product **NEW** New

4GB
8GB

96D3-4G1333NN-AP

240PIN, 1333Mb/s, 256Mx8, 1.181" Height, Hynix Chips **EOL:Q4/2016**

96D3-4G1600NN-APL **VLP**

240PIN, 1600Mb/s, 256Mx8, 0.740" Height, Hynix Chips

96D3-4G1600NN-TR

240PIN, 1600Mb/s, 256Mx8, 1.181" Height, Samsung Chips **EOL:Q4/2015**

96D3-8G1333NN-APL **VLP**

240PIN, 1333Mb/s, 512Mx8, 0.740" Height, Micron Chips **EOL:Q2/2016**

96D3-8G1600NN-APL **VLP**

240PIN, 1600Mb/s, 512Mx8, 0.740" Height, Micron Chips

96D3-8G1600NN-TR

240PIN, 1600Mb/s, 512Mx8, 1.181" Height, Micron Chips **EOL:Q4/2015**

Q1/2016

Q2/2016

Q3/2016

Q4/2016

Q1/2016

DDR3 DIMM- Advanced Feature

ECC

Available Phasing-out Planning
ECC ECC **B** Fully Buffered **R** Registered **LR** Load Reduce
LV Low Voltage **VLP** Very Low Profile **W** Wide Temperature
F Focus Product **NEW** New

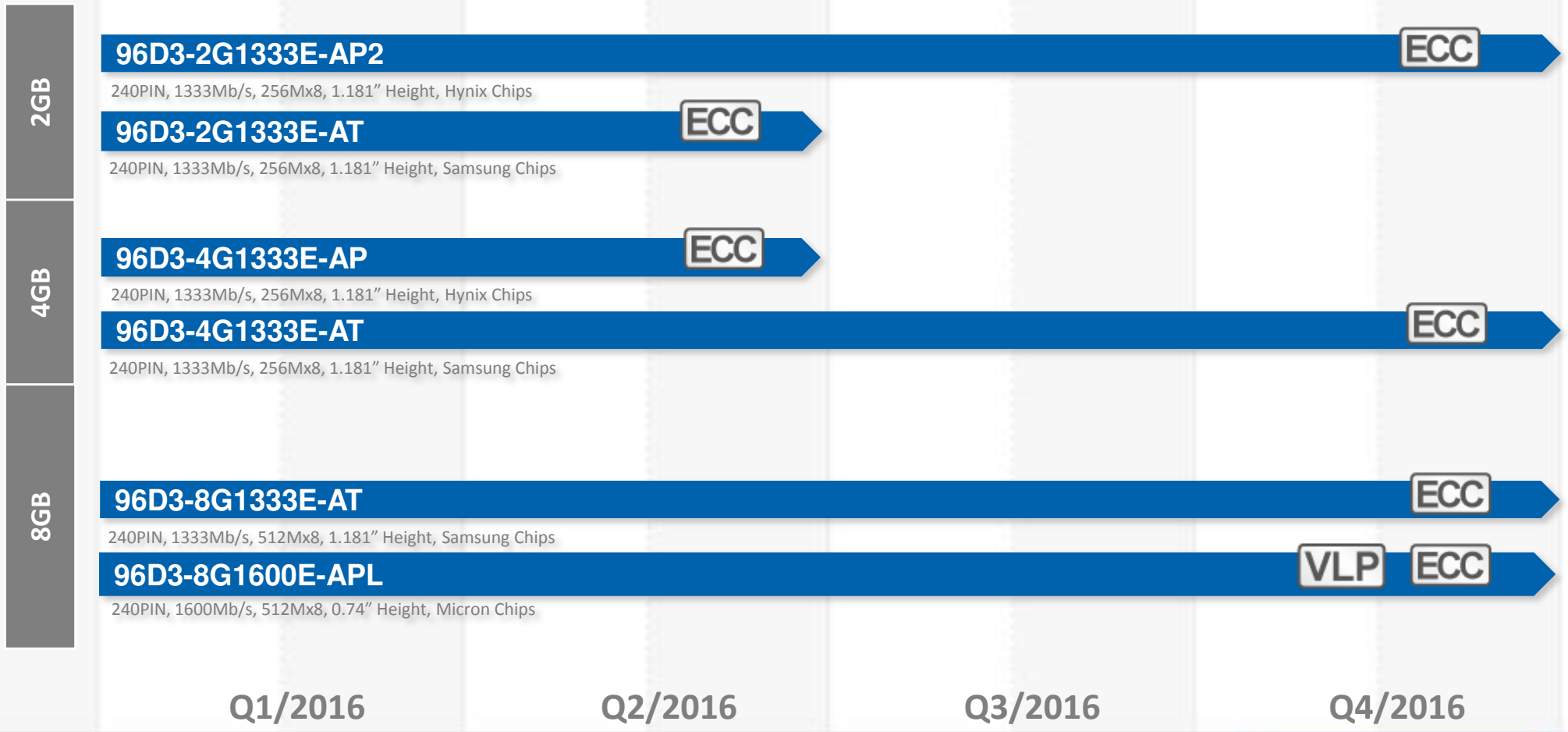

Q1/2016

Q2/2016

Q3/2016

Q4/2016

Q1/2016

Enabling an Intelligent Planet



DDR3 DIMM- Advanced Feature

Registered

Available Phasing-out Planning
ECC ECC B Fully Buffered R Registered LR Load Reduce
LV Low Voltage VLP Very Low Profile ⚠ Wide Temperature
F Focus Product NEW New



Q1/2016

Enabling an Intelligent Planet



DDR3 SO-DIMM

Available Phasing-out Planning
ECC ECC B Fully Buffered R Registered LR Load Reduce
LV Low Voltage VLP Very Low Profile ⚡ Wide Temperature
F Focus Product NEW New

1GB

96SD3-1G1333NN-TR1

204PIN, 1333Mb/s, 128Mx8, 1.181" Height, Samsung Chips

2GB

96SD3-2G1333NN-AP2

204PIN, 1333Mb/s, 256Mx8, 1.181" Height, Hynix Chips

96SD3-2G1600NN-AP

204PIN, 1600Mb/s, 256Mx8, 1.181" Height, Hynix Chips

4GB

96SD3-4G1066NN-AP

204PIN, 1066Mb/s, 256Mx8, 1.181" Height, Hynix Chips

96SD3-4G1333NN-TR2

204PIN, 1333Mb/s, 256Mx8, 1.181" Height, Samsung Chips

96SD3-4G1333NN-AP1

204PIN, 1333Mb/s, 256Mx8, 1.181" Height, Hynix Chips

96SD3-4G1600NN-AP

204PIN, 1600Mb/s, 256Mx8, 1.181" Height, Hynix Chips

8GB

96SD3-8G1333NN-TR

204PIN, 1333Mb/s, 512Mx8, 1.181" Height, Micron Chips **EOL:Q4/2015**

96SD3-8G1600NN-TR

204PIN, 1600Mb/s, 512Mx8, 1.181" Height, Micron Chips **EOL:Q4/2015**

96SD3-8G1600NN-AP

204PIN, 1600Mb/s, 512Mx8, 1.181" Height, HYNIX Chips

96SD3-8G1600NN-AT

204PIN, 1600Mb/s, 512Mx8, 1.181" Height, Samsung Chips

Q1/2016

Q1/2016

Q2/2016

Q3/2016

Q4/2016

Enabling an Intelligent Planet

ADVANTECH

DDR3 SO-DIMM- Advanced Feature

ECC

Available Phasing-out Planning

ECC ECC B Fully Buffered R Registered LR Load Reduce

LV Low Voltage VLP Very Low Profile W Wide Temperature

F Focus Product NEW New

2GB

96SD3-2G1333E-AP

ECC

204PIN, 1333Mb/s, 256Mx8, 1.181" Height, Hynix Chips

4GB

96SD3-4G1066E-AP

ECC

204PIN, 1066Mb/s, 256Mx8, 1.181" Height, Hynix Chips

8GB

96SD3-8G1333E-TR

ECC

204PIN, 1333Mb/s, 512Mx8, 1.181" Height, Samsung Chips

Low Voltage

4GB

96SD3L-4G1333NN-AP

LV

Apacer, 204PIN, 1333Mb/s, 512Mx8, 1.35V, 1.181" Height, MICRO Chips

8GB

96SD3L-8G1333NN-AP

LV

204PIN, 1333Mb/s, 512Mx8, 1.35V, 1.181" Height, MICRO Chips

Q1/2016

Q2/2016

Q3/2016

Q4/2016

Q1/2016

Enabling an Intelligent Planet

ADVANTECH

Memory EOL Procedure

- For support and product management optimization, PAPS will follow the Memory phase-out procedure as below.



Thank you

