

## +2.7V, Low-Power, Multichannel, Serial 8-Bit ADCs

### General Description

The MAX1110/MAX1111 low-power, 8-bit, 8-channel analog-to-digital converters (ADCs) feature an internal track/hold, voltage reference, clock, and serial interface. They operate from a single 2.7V to 5.5V supply and consume only 85 $\mu$ A while sampling at rates up to 50ksps. The MAX1110's 8 analog inputs and the MAX1111's 4 analog inputs are software-configurable, allowing unipolar/bipolar and single-ended/differential operation.

Successive-approximation conversions are performed using either the internal clock or an external serial-interface clock. The full-scale analog input range is determined by the 2.048V internal reference, or by an externally applied reference ranging from 1V to  $V_{DD}$ . The 4-wire serial interface is compatible with the SPI™, QSPI™, and MICROWIRE™ serial-interface standards. A serial-strobe output provides the end-of-conversion signal for interrupt-driven processors.

The MAX1110/MAX1111 have a software-programmable, 2 $\mu$ A automatic power-down mode to minimize power consumption. Using power-down, the supply current is reduced to 6 $\mu$ A at 1ksps, and only 52 $\mu$ A at 10ksps. Power-down can also be controlled using the SHDN input pin. Accessing the serial interface automatically powers up the device.

The MAX1110 is available in a 20-pin SSOP package. The MAX1111 is available in a small 16-pin QSOP package.

### Applications

- Portable Data Logging
- Hand-Held Measurement Devices
- Medical Instruments
- System Diagnostics
- Solar-Powered Remote Systems
- 4mA to 20mA-Powered Remote Data-Acquisition Systems

Pin Configurations appear at end of data sheet.

SPI and QSPI are trademarks of Motorola, Inc.  
MICROWIRE is a trademark of National Semiconductor Corp.

### Features

- ◆ 2.7V to 5.5V Single Supply
- ◆ Low Power: 85 $\mu$ A at 50ksps  
6 $\mu$ A at 1ksps
- ◆ 8-Channel Single-Ended or 4-Channel Differential Inputs (MAX1110)
- ◆ 4-Channel Single-Ended or 2-Channel Differential Inputs (MAX1111)
- ◆ Internal Track/Hold; 50kHz Sampling Rate
- ◆ Internal 2.048V Reference
- ◆ SPI/QSPI/MICROWIRE-Compatible Serial Interface
- ◆ Software-Configurable Unipolar or Bipolar Inputs
- ◆ Total Unadjusted Error:  $\pm 1$  LSB (max)  
 $\pm 0.3$  LSB (typ)

Ordering Information appears at end of data sheet.

### Functional Diagram

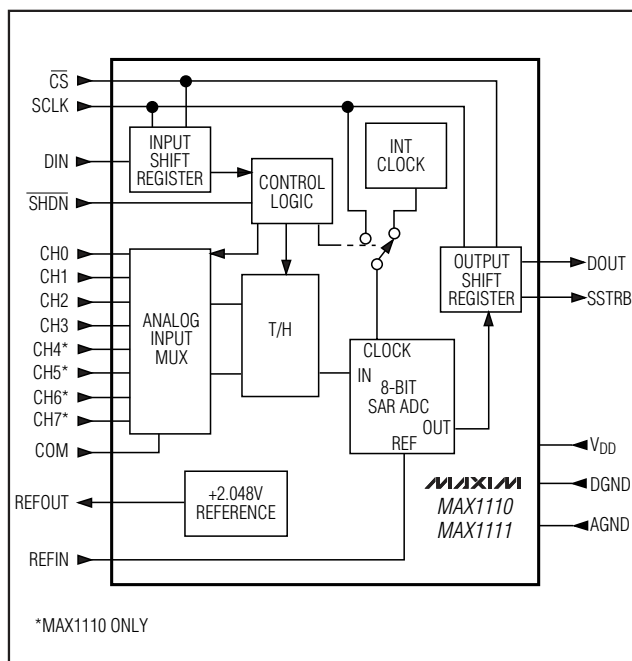

# +2.7V, Low-Power, Multichannel, Serial 8-Bit ADCs

## ABSOLUTE MAXIMUM RATINGS

V <sub>DD</sub> to AGND	-0.3V to 6V
AGND to DGND	-0.3V to 0.3V
CH0–CH7, COM, REFIN, REFOUT to AGND	-0.3V to (V <sub>DD</sub> + 0.3V)
Digital Inputs to DGND	-0.3V to 6V
Digital Outputs to DGND	-0.3V to (V <sub>DD</sub> + 0.3V)
Continuous Power Dissipation (T <sub>A</sub> = +70°C)	
QSOP (derate 8.30mW/°C above +70°C)	667mW
SSOP (derate 8.00mW/°C above +70°C)	640mW

### Operating Temperature Ranges

MAX1110CAP/MAX1111CEE	0°C to +70°C
MAX1110EAP/MAX1111EGE	-40°C to +85°C
Storage Temperature Range	-65°C to +150°C
Lead Temperature (soldering, 10s)	+300°C
Soldering Temperature (reflow)	+260°C

Stresses beyond those listed under “Absolute Maximum Ratings” may cause permanent damage to the device. These are stress ratings only, and functional operation of the device at these or any other conditions beyond those indicated in the operational sections of the specifications is not implied. Exposure to absolute maximum rating conditions for extended periods may affect device reliability.

## ELECTRICAL CHARACTERISTICS

(V<sub>DD</sub> = 2.7V to 5.5V; unipolar input mode; V<sub>COM</sub> = 0V; f<sub>SCLK</sub> = 500kHz, external clock (50% duty cycle); 10 clocks/conversion cycle (50ksps); 1μF capacitor at REFOUT; T<sub>A</sub> = T<sub>MIN</sub> to T<sub>MAX</sub>; unless otherwise noted.)

PARAMETER	SYMBOL	CONDITIONS	MIN	TYP	MAX	UNITS
<b>DC ACCURACY</b>						
Resolution			8			Bits
Relative Accuracy (Note 1)	INL	V <sub>DD</sub> = 2.7V to 3.6V		±0.15	±0.5	LSB
		V <sub>DD</sub> = 5.5V (Note 2)		±0.2		
Differential Nonlinearity	DNL	No missing codes over temperature			±1	LSB
Offset Error		V <sub>DD</sub> = 2.7V to 3.6V		±0.35	±1	LSB
		V <sub>DD</sub> = 5.5V (Note 2)		±0.5		
Gain Error (Note 3)		Internal or external reference			±1	LSB
Gain Temperature Coefficient		External reference, 2.048V		±0.8		ppm/°C
Total Unadjusted Error	TUE			±0.3	±1	LSB
Channel-to-Channel Offset Matching				±0.1		LSB
<b>DYNAMIC SPECIFICATIONS (10.034kHz sine-wave input, 2.048V<sub>p-p</sub>, 50ksps, 500kHz external clock)</b>						
Signal-to-Noise and Distortion Ratio	SINAD			49		dB
Total Harmonic Distortion (up to the 5th harmonic)	THD			-70		dB
Spurious-Free Dynamic Range	SFDR			68		dB
Channel-to-Channel Crosstalk		V <sub>CH<sub>L</sub></sub> = 2.048V <sub>p-p</sub> , 25kHz (Note 4)		-75		dB
Small-Signal Bandwidth		-3dB rolloff		1.5		MHz
Full-Power Bandwidth				800		kHz

# +2.7V, Low-Power, Multichannel, Serial 8-Bit ADCs

MAX1110/MAX1111

## ELECTRICAL CHARACTERISTICS (continued)

( $V_{DD}$  = 2.7V to 5.5V; unipolar input mode;  $V_{COM}$  = 0V;  $f_{SCLK}$  = 500kHz, external clock (50% duty cycle); 10 clocks/conversion cycle (50ksp/s); 1 $\mu$ F capacitor at REFOUT;  $T_A$  =  $T_{MIN}$  to  $T_{MAX}$ ; unless otherwise noted.)

PARAMETER	SYMBOL	CONDITIONS	MIN	TYP	MAX	UNITS
<b>CONVERSION RATE</b>						
Conversion Time (Note 5)	$t_{CONV}$	Internal clock		25	55	$\mu$ s
		External clock, 500kHz, 10 clocks/conversion	20			
Track/Hold Acquisition Time	$t_{ACQ}$	External clock, 2MHz	1			$\mu$ s
Aperture Delay				10		ns
Aperture Jitter				<50		ps
Internal Clock Frequency				400		kHz
External Clock-Frequency Range		(Note 6)	50		500	kHz
		Used for data transfer only			2	MHz
<b>ANALOG INPUT</b>						
Input Voltage Range, Single-Ended and Differential (Note 7)		Unipolar input, $V_{COM}$ = 0V	0		$V_{REFIN}$	V
		Bipolar input, $V_{COM}$ = $V_{REFIN}/2$			$V_{COM} \pm V_{REFIN}/2$	
Multiplexer Leakage Current		On/off-leakage current, $V_{CH\_}$ = 0V or $V_{DD}$		$\pm 0.01$	$\pm 1$	$\mu$ A
Input Capacitance				18		pF
<b>INTERNAL REFERENCE</b>						
REFOUT Voltage			1.968	2.048	2.128	V
REFOUT Short-Circuit Current				3.5		mA
REFOUT Temperature Coefficient				$\pm 50$		ppm/ $^{\circ}$ C
Load Regulation (Note 8)		0 to 0.5mA output load		2.5		mV
Capacitive Bypass at REFOUT			1			$\mu$ F
<b>EXTERNAL REFERENCE AT REFIN</b>						
Input Voltage Range			1		$V_{DD} + 0.05$	V
Input Current		(Note 9)		1	20	$\mu$ A
<b>POWER REQUIREMENTS</b>						
Supply Voltage	$V_{DD}$		2.7		5.5	V
Supply Current (Note 2)	$I_{DD}$	$V_{DD}$ = 2.7V to 3.6V Full-scale input $C_{LOAD}$ = 10pF	Operating mode	85	250	$\mu$ A
			Reference disabled	45		
		$V_{DD}$ = 5.5V Full-scale input $C_{LOAD}$ = 10pF	Operating mode	120	250	
			Reference disabled	80		
		Power-down	Software	2		
SHDN at DGND	3.2		10			
Power-Supply Rejection (Note 10)	PSR	$V_{DD}$ = 2.7V to 3.6V; external reference, 2.048V; full-scale input		$\pm 0.4$	$\pm 4$	mV

# +2.7V, Low-Power, Multichannel, Serial 8-Bit ADCs

## ELECTRICAL CHARACTERISTICS (continued)

( $V_{DD}$  = 2.7V to 5.5V; unipolar input mode;  $V_{COM}$  = 0V;  $f_{SCLK}$  = 500kHz, external clock (50% duty cycle); 10 clocks/conversion cycle (50ksp/s); 1 $\mu$ F capacitor at REFOUT;  $T_A$  =  $T_{MIN}$  to  $T_{MAX}$ ; unless otherwise noted.)

PARAMETER	SYMBOL	CONDITIONS	MIN	TYP	MAX	UNITS
<b>DIGITAL INPUTS: DIN, SCLK, <math>\overline{CS}</math></b>						
DIN, SCLK, $\overline{CS}$ Input High Voltage	$V_{IH}$	$V_{DD} \leq 3.6V$	2			V
		$V_{DD} > 3.6V$	3			
DIN, SCLK, $\overline{CS}$ Input Low Voltage	$V_{IL}$				0.8	V
DIN, SCLK, $\overline{CS}$ Input Hysteresis	$V_{HYST}$			0.2		V
DIN, SCLK, $\overline{CS}$ Input Leakage	$I_{IN}$	Digital inputs = 0V or $V_{DD}$			$\pm 1$	$\mu A$
DIN, SCLK, $\overline{CS}$ Input Capacitance	$C_{IN}$	(Note 6)			15	pF
<b><math>\overline{SHDN}</math> INPUT</b>						
$\overline{SHDN}$ Input High Voltage	$V_{SH}$		$V_{DD} - 0.4$			V
$\overline{SHDN}$ Input Mid-Voltage	$V_{SM}$		1.1	$V_{DD} - 1.1$		V
$\overline{SHDN}$ Voltage, High Impedance	$V_{FLT}$	$\overline{SHDN}$ = open	$V_{DD}/2$			V
$\overline{SHDN}$ Input Low Voltage	$V_{SL}$				0.4	V
$\overline{SHDN}$ Input Current		$V_{\overline{SHDN}}$ = 0V or $V_{DD}$			$\pm 4$	$\mu A$
$\overline{SHDN}$ Maximum Allowed Leakage for Mid-Input		$\overline{SHDN}$ = open			$\pm 100$	nA
<b>DIGITAL OUTPUTS: DOUT, SSTRB</b>						
Output Low Voltage	$V_{OL}$	$I_{SINK} = 5mA$			0.4	V
		$I_{SINK} = 16mA$			0.8	
Output High Voltage	$V_{OH}$	$I_{SOURCE} = 0.5mA$	$V_{DD} - 0.5$			V
Three-State Leakage Current	$I_L$	$\overline{CS} = V_{DD}$	$\pm 0.01$		$\pm 10$	$\mu A$
Three-State Output Capacitance	$C_{OUT}$	$\overline{CS} = V_{DD}$ (Note 6)			15	pF

# +2.7V, Low-Power, Multichannel, Serial 8-Bit ADCs

MAX1110/MAX1111

## TIMING CHARACTERISTICS (Figures 8 and 9)

( $V_{DD} = 2.7V$  to  $5.5V$ ,  $T_A = T_{MIN}$  to  $T_{MAX}$ , unless otherwise noted.)

PARAMETER	SYMBOL	CONDITIONS	MIN	TYP	MAX	UNITS
Track/Hold Acquisition Time	$t_{ACQ}$		1			$\mu s$
DIN to SCLK Setup	$t_{DS}$		100			ns
DIN to SCLK Hold	$t_{DH}$		0			ns
SCLK Fall to Output Data Valid	$t_{DO}$	Figure 1, $C_{LOAD} = 100pF$	20		200	ns
$\overline{CS}$ Fall to Output Enable	$t_{DV}$	Figure 1, $C_{LOAD} = 100pF$			240	ns
$\overline{CS}$ Rise to Output Disable	$t_{TR}$	Figure 2, $C_{LOAD} = 100pF$			240	ns
$\overline{CS}$ to SCLK Rise Setup	$t_{CSS}$		100			ns
$\overline{CS}$ to SCLK Rise Hold	$t_{CSH}$		0			ns
SCLK Pulse Width High	$t_{CH}$		200			ns
SCLK Pulse Width Low	$t_{CL}$		200			ns
SCLK Fall to SSTRB	$t_{SSTRB}$	$C_{LOAD} = 100pF$			240	ns
$\overline{CS}$ Fall to SSTRB Output Enable (Note 6)	$t_{SDV}$	Figure 1, external clock mode only, $C_{LOAD} = 100pF$			240	ns
$\overline{CS}$ Rise to SSTRB output Disable (Note 6)	$t_{STR}$	Figure 2, external clock mode only, $C_{LOAD} = 100pF$			240	ns
SSTRB Rise to SCLK Rise (Note 6)	$t_{SCK}$	Figure 11, internal clock mode only	0			ns
Wake-Up Time	$t_{WAKE}$	External reference		20		$\mu s$
		Internal reference (Note 11)		12		ms

**Note 1:** Relative accuracy is the analog value's deviation (at any code) from its theoretical value after the full-scale range is calibrated.

**Note 2:** See *Typical Operating Characteristics*.

**Note 3:**  $V_{REFIN} = 2.048V$ , offset nulled.

**Note 4:** On-channel grounded; sine wave applied to all off-channels.

**Note 5:** Conversion time is defined as the number of clock cycles multiplied by the clock period; clock has 50% duty cycle.

**Note 6:** Guaranteed by design. Not subject to production testing.

**Note 7:** Common-mode range for the analog inputs is from AGND to  $V_{DD}$ .

**Note 8:** External load should not change during the conversion for specified accuracy.

**Note 9:** External reference at 2.048V, full-scale input, 500kHz external clock.

**Note 10:** Measured as  $|V_{FS}(2.7V) - V_{FS}(3.6V)|$ .

**Note 11:**  $1\mu F$  at REFOUT; internal reference settling to 0.5 LSB.

# +2.7V, Low-Power, Multichannel, Serial 8-Bit ADCs

## Typical Operating Characteristics

( $V_{DD} = 2.7V$ ;  $f_{SCLK} = 500kHz$ ; external clock (50% duty cycle);  $R_L = \infty$ ;  $T_A = +25^\circ C$ , unless otherwise noted.)

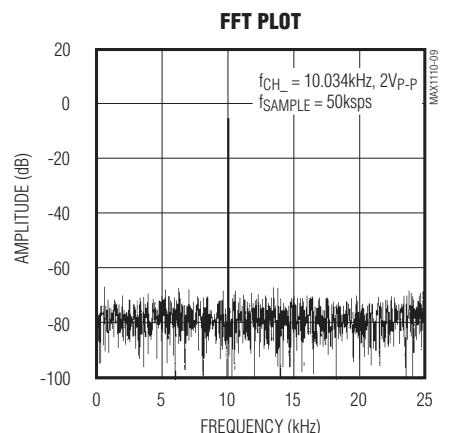
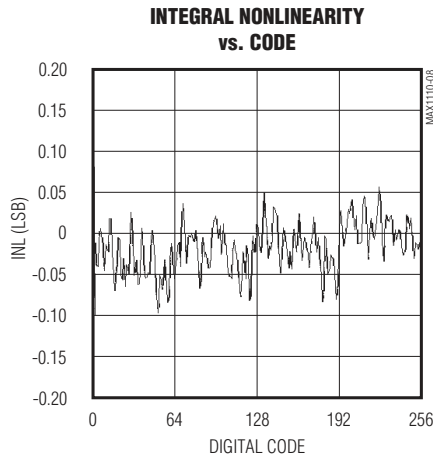
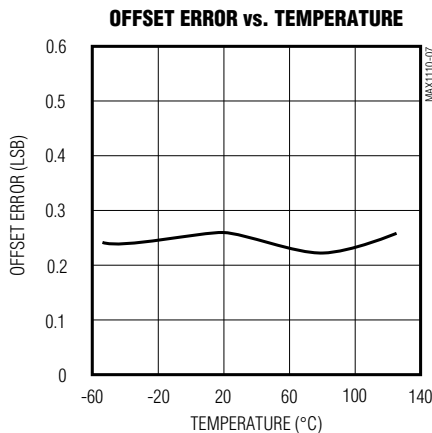
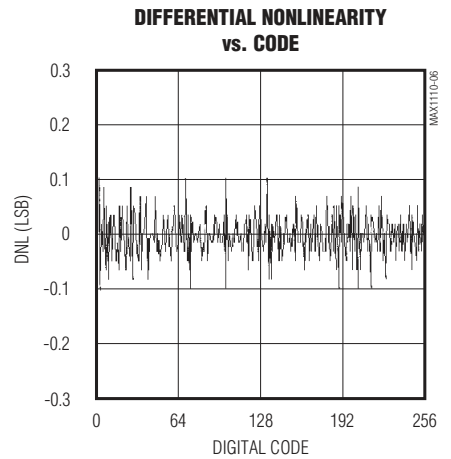
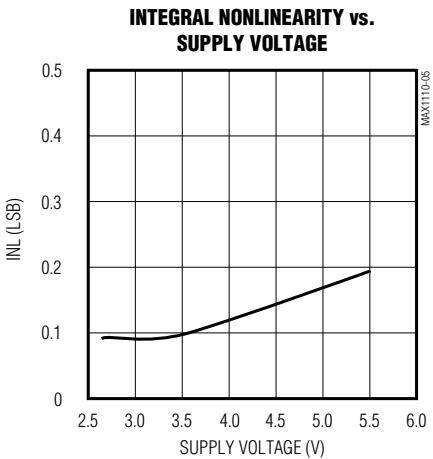
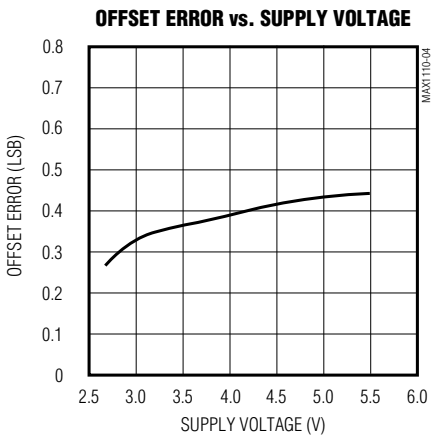
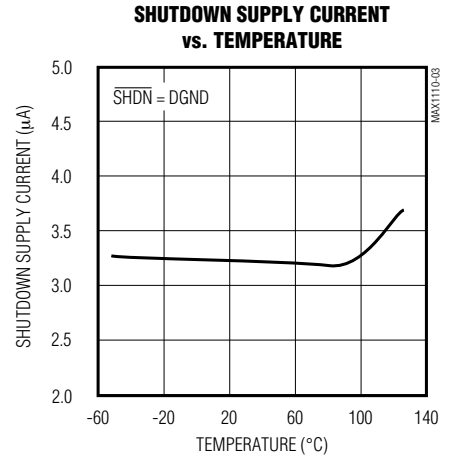
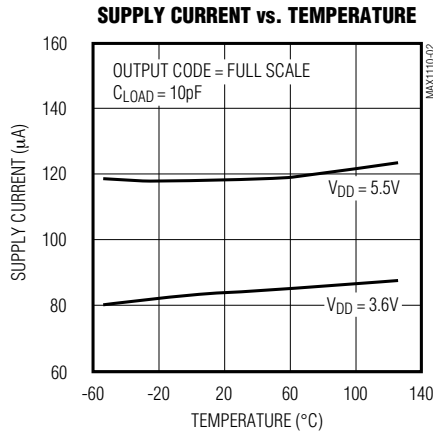
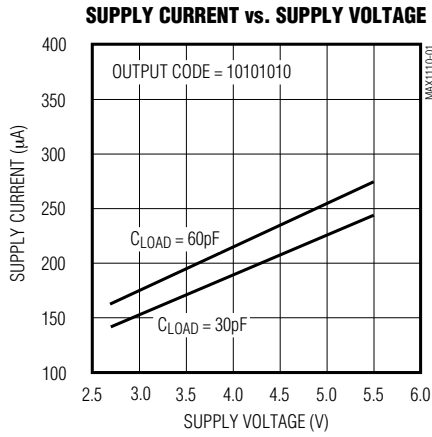

# +2.7V, Low-Power, Multichannel, Serial 8-Bit ADCs

## Pin Description

MAX1110/MAX1111

PIN		NAME	FUNCTION
MAX1110	MAX1111		
1–4	1–4	CH0–CH3	Sampling Analog Inputs
5–8	—	CH4–CH7	Sampling Analog Inputs
9	5	COM	Ground Reference for Analog Inputs. Sets zero-code voltage in single-ended mode. Must be stable to $\pm 0.5$ LSB.
10	6	$\overline{\text{SHDN}}$	Three-Level Shutdown Input. Normally high impedance. Pulling $\overline{\text{SHDN}}$ low shuts the MAX1110/MAX1111 down to 10 $\mu\text{A}$ (max) supply current; otherwise, the devices are fully operational. Pulling $\overline{\text{SHDN}}$ high shuts down the internal reference.
11	7	REFIN	Reference Voltage Input for Analog-to-Digital Conversion. Connect to REFOUT to use the internal reference.
12	8	REFOUT	Internal Reference Generator Output. Bypass with a 1 $\mu\text{F}$ capacitor to AGND.
13	9	AGND	Analog Ground
14	10	DGND	Digital Ground
15	11	DOUT	Serial-Data Output. Data is clocked out on SCLK's falling edge. High impedance when $\overline{\text{CS}}$ is high.
16	12	SSTRB	Serial-Strobe Output. In internal clock mode, SSTRB goes low when the MAX1110/MAX1111 begin the A/D conversion and goes high when the conversion is done. In external clock mode, SSTRB pulses high for two clock periods before the MSB is shifted out. High impedance when $\overline{\text{CS}}$ is high (external clock mode only).
17	13	DIN	Serial-Data Input. Data is clocked in at SCLK's rising edge. The voltage at DIN can exceed $V_{\text{DD}}$ (up to 5.5V).
18	14	$\overline{\text{CS}}$	Active-Low Chip Select. Data is not clocked into DIN unless $\overline{\text{CS}}$ is low. When $\overline{\text{CS}}$ is high, DOUT is high impedance. The voltage at $\overline{\text{CS}}$ can exceed $V_{\text{DD}}$ (up to 5.5V).
19	15	SCLK	Serial-Clock Input. Clocks data in and out of serial interface. In external clock mode, SCLK also sets the conversion speed (duty cycle must be 45% to 55%). The voltage at SCLK can exceed $V_{\text{DD}}$ (up to 5.5V).
20	16	$V_{\text{DD}}$	Positive Supply Voltage, 2.7V to 5.5V

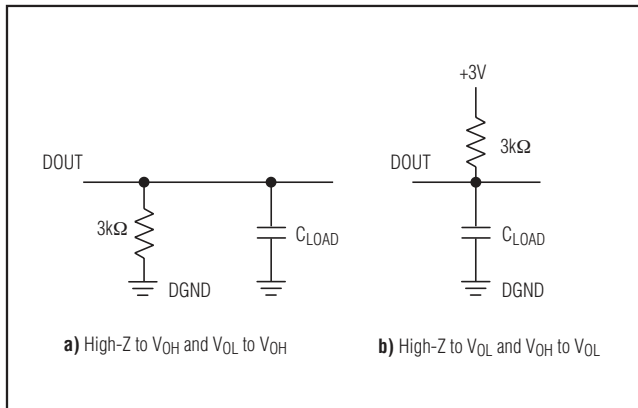

Figure 1. Load Circuits for Enable Time

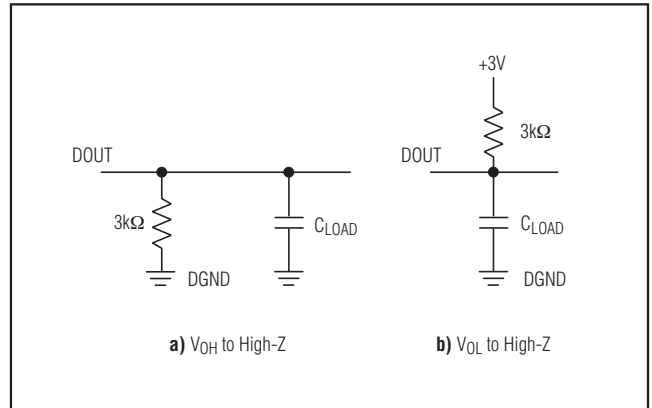

Figure 2. Load Circuits for Disable Time

# +2.7V, Low-Power, Multichannel, Serial 8-Bit ADCs

## Detailed Description

The MAX1110/MAX1111 analog-to-digital converters (ADCs) use a successive-approximation conversion technique and input track/hold (T/H) circuitry to convert an analog signal to an 8-bit digital output. A flexible serial interface provides easy interface to microprocessors ( $\mu$ Ps). Figure 3 shows the Typical Operating Circuit.

## Pseudo-Differential Input

The sampling architecture of the ADC's analog comparator is illustrated in Figure 4, the equivalent input circuit. In single-ended mode,  $IN+$  is internally switched to the selected input channel,  $CH_n$ , and  $IN-$  is switched to COM. In differential mode,  $IN+$  and  $IN-$  are selected from the following pairs:  $CH0/CH1$ ,  $CH2/CH3$ ,  $CH4/CH5$ , and  $CH6/CH7$ . Configure the MAX1110 channels with Table 1 and the MAX1111 channels with Table 2.

In differential mode,  $IN-$  and  $IN+$  are internally switched to either of the analog inputs. This configuration is pseudo-differential to the effect that only the signal at  $IN+$  is sampled. The return side ( $IN-$ ) must remain stable within  $\pm 0.5$  LSB ( $\pm 0.1$  LSB for best results) with respect to AGND during a conversion. To accomplish this, connect a  $0.1\mu F$  capacitor from  $IN-$  (the selected analog input) to AGND.

During the acquisition interval, the channel selected as the positive input ( $IN+$ ) charges capacitor  $CHOLD$ . The

acquisition interval spans two SCLK cycles and ends on the falling SCLK edge after the last bit of the input control word has been entered. At the end of the acquisition interval, the T/H switch opens, retaining charge on  $CHOLD$  as a sample of the signal at  $IN+$ . The conversion interval begins with the input multiplexer switching  $CHOLD$  from the positive input ( $IN+$ ) to the negative input ( $IN-$ ). In single-ended mode,  $IN-$  is simply COM. This unbalances node ZERO at the input of the comparator. The capacitive DAC adjusts during the remainder of the conversion cycle to restore node ZERO to 0V within the limits of 8-bit resolution. This action is equivalent to transferring a charge of  $18pF \times (V_{IN+} - V_{IN-})$  from  $CHOLD$  to the binary-weighted capacitive DAC, which in turn forms a digital representation of the analog input signal.

## Track/Hold

The T/H enters its tracking mode on the falling clock edge after the sixth bit of the 8-bit control byte has been shifted in. It enters its hold mode on the falling clock edge after the eighth bit of the control byte has been shifted in. If the converter is set up for single-ended inputs,  $IN-$  is connected to COM, and the converter samples the "+" input; if it is set up for differential inputs,  $IN-$  connects to the "-" input, and the difference ( $IN+ - IN-$ ) is sampled. At the end of the conversion, the positive input connects back to  $IN+$ , and  $CHOLD$  charges to the input signal.

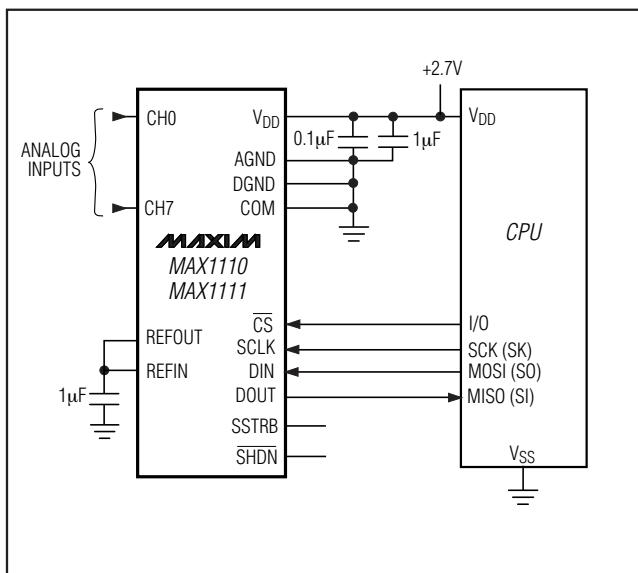

Figure 3. Typical Operating Circuit

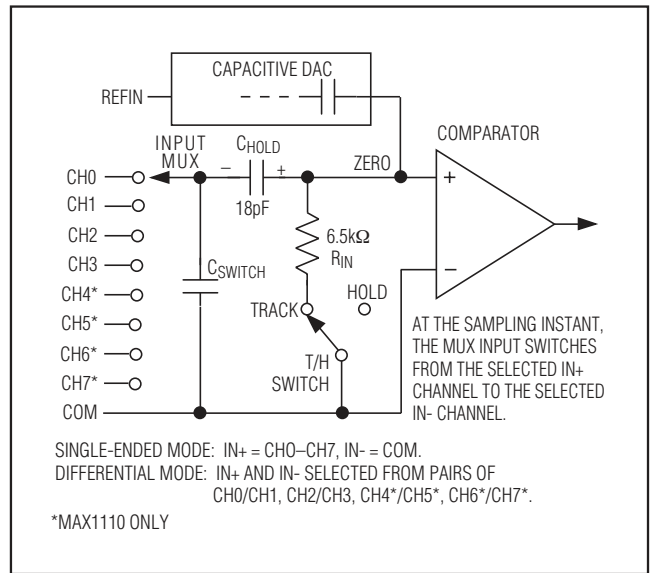

Figure 4. Equivalent Input Circuit



# +2.7V, Low-Power, Multichannel, Serial 8-Bit ADCs

MAX1110/MAX1111

**Table 1a. MAX1110 Channel Selection in Single-Ended Mode (SGL/DIF = 1)**

SEL2	SEL1	SEL0	CH0	CH1	CH2	CH3	CH4	CH5	CH6	CH7	COM
0	0	0	+								-
1	0	0		+							-
0	0	1			+						-
1	0	1				+					-
0	1	0					+				-
1	1	0						+			-
0	1	1							+		-
1	1	1								+	-

**Table 1b. MAX1110 Channel Selection in Differential Mode (SGL/DIF = 0)**

SEL2	SEL1	SEL0	CH0	CH1	CH2	CH3	CH4	CH5	CH6	CH7
0	0	0	+	-						
0	0	1			+	-				
0	1	0					+	-		
0	1	1							+	-
1	0	0	-	+						
1	0	1			-	+				
1	1	0					-	+		
1	1	1							-	+

**Table 2a. MAX1111 Channel Selection in Single-Ended Mode (SGL/DIF = 1)**

SEL2	SEL1	SEL0	CH0	CH1	CH2	CH3	COM
0	0	X	+				-
1	0	X		+			-
0	1	X			+		-
1	1	X				+	-

**Table 2b. MAX1111 Channel Selection in Differential Mode (SGL/DIF = 0)**

SEL2	SEL1	SEL0	CH0	CH1	CH2	CH3
0	0	X	+	-		
0	1	X			+	-
1	0	X	-	+		
1	1	X			-	+

## +2.7V, Low-Power, Multichannel, Serial 8-Bit ADCs

The time required for the T/H to acquire an input signal is a function of how quickly its input capacitance is charged. If the input signal's source impedance is high, the acquisition time lengthens, and more time must be allowed between conversions. The acquisition time,  $t_{ACQ}$ , is the minimum time needed for the signal to be acquired. It is calculated by:

$$t_{ACQ} = 6 \times (R_S + R_{IN}) \times 18\text{pF}$$

where  $R_{IN} = 6.5\text{k}\Omega$ ,  $R_S$  = the source impedance of the input signal, and  $t_{ACQ}$  is never less than  $1\mu\text{s}$ . Note that source impedances below  $2.4\text{k}\Omega$  do not significantly affect the AC performance of the ADC.

### Input Bandwidth

The ADC's input tracking circuitry has a 1.5MHz small-signal bandwidth, so it is possible to digitize high-speed transient events and measure periodic signals with bandwidths exceeding the ADC's sampling rate by using undersampling techniques. To avoid high-frequency signals being aliased into the frequency band of interest, anti-alias filtering is recommended.

### Analog Inputs

Internal protection diodes, which clamp the analog input to  $V_{DD}$  and AGND, allow the channel input pins to swing from (AGND - 0.3V) to ( $V_{DD} + 0.3\text{V}$ ) without dam-

age. However, for accurate conversions near full scale, the inputs must not exceed  $V_{DD}$  by more than 50mV or be lower than AGND by 50mV.

**If the analog input exceeds 50mV beyond the supplies, do not forward bias the protection diodes of off channels over 2mA.**

The MAX1110/MAX1111 can be configured for differential or single-ended inputs with bits 2 and 3 of the control byte (Table 3). In single-ended mode, the analog inputs are internally referenced to COM with a full-scale input range from COM to  $V_{REFIN} + \text{COM}$ . For bipolar operation, set COM to  $V_{REFIN}/2$ .

In differential mode, choosing unipolar mode sets the differential input range at 0V to  $V_{REFIN}$ . In unipolar mode, the output code is invalid (code zero) when a negative differential input voltage is applied. Bipolar mode sets the differential input range to  $\pm V_{REFIN}/2$ . Note that in this mode, the common-mode input range includes both supply rails. Refer to Table 4 for input voltage ranges.

### Quick Look

To quickly evaluate the MAX1110/MAX1111's analog performance, use the circuit of Figure 5. The MAX1110/MAX1111 require a control byte to be written to DIN before each conversion. Tying DIN to +3V feeds

**Table 3. Control-Byte Format**

BIT 7 (MSB)	BIT 6	BIT 5	BIT 4	BIT 3	BIT 2	BIT 1	BIT 0 (LSB)
START	SEL2	SEL1	SEL0	UNI/BIP	SGL/DIF	PD1	PD0

BIT	NAME	DESCRIPTION
7 (MSB)	START	The first logic "1" bit after $\overline{CS}$ goes low defines the beginning of the control byte.
6 5 4	SEL2 SEL1 SEL0	Select which of the input channels are to be used for the conversion (Tables 1 and 2).
3	UNI/BIP	<b>1</b> = unipolar, <b>0</b> = bipolar. Selects unipolar or bipolar conversion mode. Select differential operation if bipolar mode is used (Table 4).
2	SGL/DIF	<b>1</b> = single ended, <b>0</b> = differential. Selects single-ended or differential conversions. In single-ended mode, input signal voltages are referred to COM. In differential mode, the voltage difference between two channels is measured (Tables 1 and 2).
1	PD1	<b>1</b> = fully operational, <b>0</b> = power-down. Selects fully operational or power-down mode.
0 (LSB)	PD0	<b>1</b> = external clock mode, <b>0</b> = internal clock mode. Selects external or internal clock mode.

# +2.7V, Low-Power, Multichannel, Serial 8-Bit ADCs

MAX1110/MAX1111

**Table 4. Full-Scale and Zero-Scale Voltages**

UNIPOLAR MODE		BIPOLAR MODE		
Full Scale	Zero Scale	Positive Full Scale	Zero Scale	Negative Full Scale
$V_{REFIN} + COM$	COM	$+V_{REFIN}/2 + COM$	COM	$-V_{REFIN}/2 + COM$

in control bytes of \$FF (hex), which trigger single-ended, unipolar conversions on CH7 (MAX1110) or CH3 (MAX1111) in external clock mode without powering down between conversions. In external clock mode, the SSTRB output pulses high for two clock periods before the most significant bit of the 8-bit conversion result is shifted out of DOUT. Varying the analog input alters the output code. A total of 10 clock cycles is required per conversion. All transitions of the SSTRB and DOUT outputs occur on SCLK's falling edge.

### How to Start a Conversion

A conversion is started by clocking a control byte into DIN. With  $\overline{CS}$  low, each rising edge on SCLK clocks a bit from DIN into the MAX1110/MAX1111's internal shift reg-

ister. After  $\overline{CS}$  falls, the first arriving logic "1" bit at DIN defines the MSB of the control byte. Until this first start bit arrives, any number of logic "0" bits can be clocked into DIN with no effect. Table 3 shows the control-byte format.

The MAX1110/MAX1111 are compatible with MICROWIRE, SPI, and QSPI devices. For SPI, select the correct clock polarity and sampling edge in the SPI control registers: set CPOL = 0 and CPHA = 0. MICROWIRE, SPI, and QSPI all transmit a byte and receive a byte at the same time. Using the Typical Operating Circuit (Figure 3), the simplest software interface requires three 8-bit transfers to perform a conversion (one 8-bit transfer to configure the ADC, and two more 8-bit transfers to clock out the 8-bit conversion result). Figure 6 shows the MAX1110/MAX1111 common serial-interface connections.

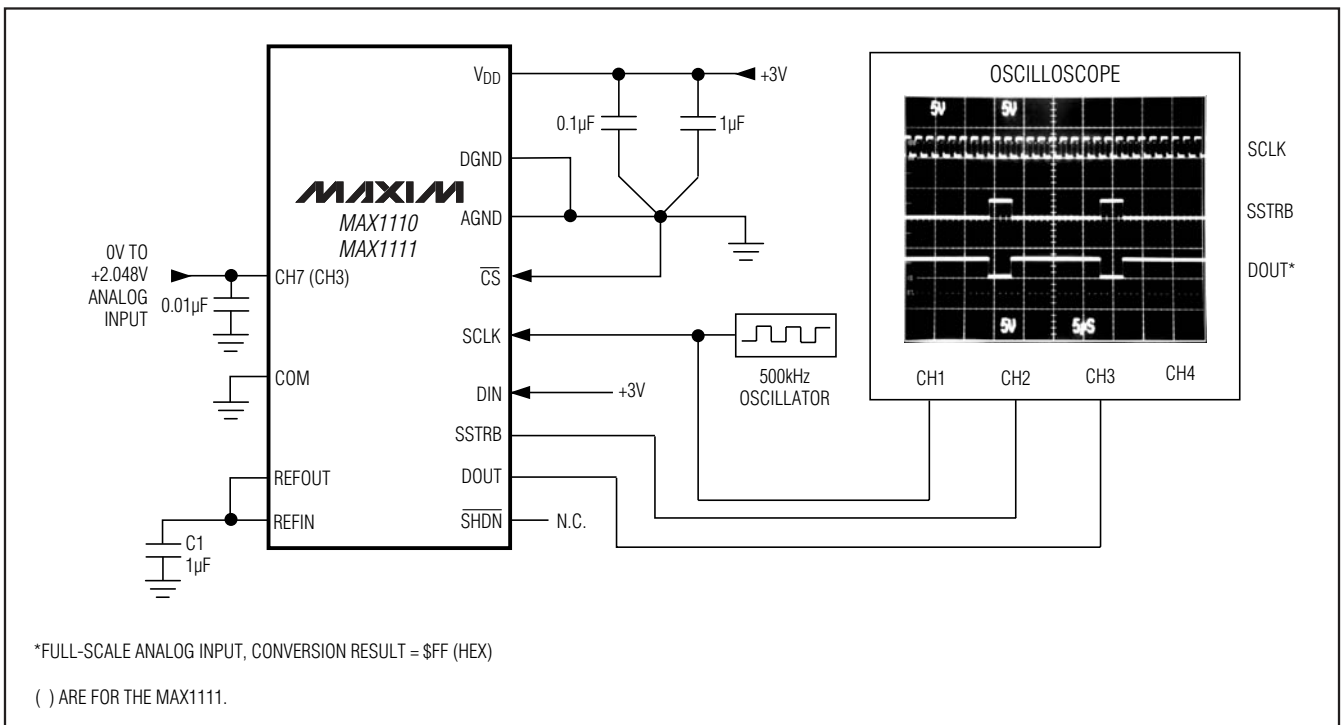

Figure 5. Quick-Look Circuit

# +2.7V, Low-Power, Multichannel, Serial 8-Bit ADCs

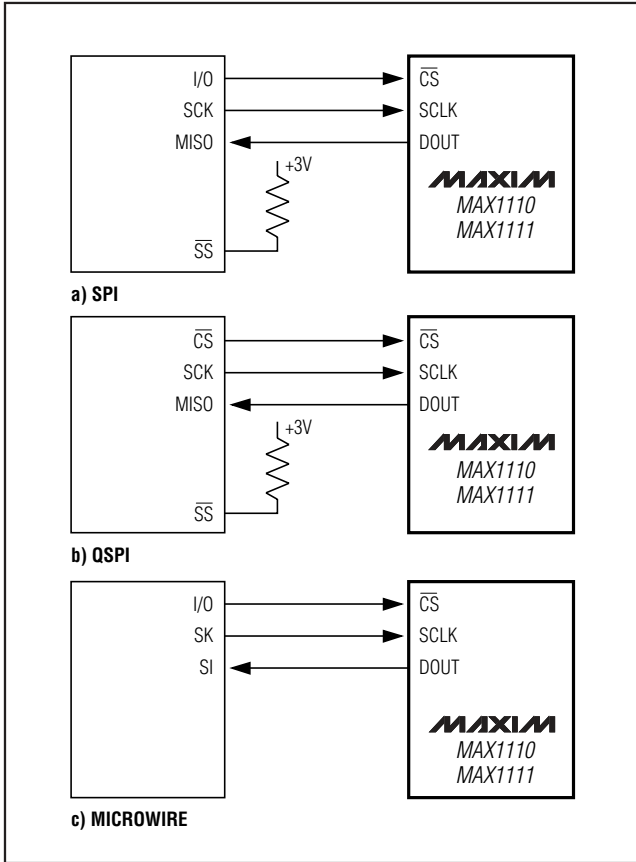

Figure 6. Common Serial-Interface Connections to the MAX1110/MAX1111

### Simple Software Interface

Make sure the CPU's serial interface runs in master mode so the CPU generates the serial clock. Choose a clock frequency from 50kHz to 500kHz.

- 1) Set up the control byte for external clock mode and call it TB1. TB1 should be of the format 1XXXXX11 binary, where the Xs denote the particular channel and conversion mode selected.
- 2) Use a general-purpose I/O line on the CPU to pull  $\overline{CS}$  low.
- 3) Transmit TB1 and, simultaneously, receive a byte and call it RB1. Ignore RB1.
- 4) Transmit a byte of all zeros (\$00 hex) and, simultaneously, receive byte RB2.
- 5) Transmit a byte of all zeros (\$00 hex) and, simultaneously, receive byte RB3.
- 6) Pull  $\overline{CS}$  high.

Figure 7 shows the timing for this sequence. Bytes RB2 and RB3 contain the result of the conversion padded with two leading zeros and six trailing zeros. The total conversion time is a function of the serial-clock frequency and the amount of idle time between 8-bit transfers. Make sure that the total conversion time does not exceed 1ms, to avoid excessive T/H droop.

### Digital Inputs

$\overline{CS}$ , SCLK, and DIN can accept input signals up to 5.5V, regardless of the supply voltages. This allows the MAX1110/MAX1111 to accept digital inputs from both 3V and 5V systems.

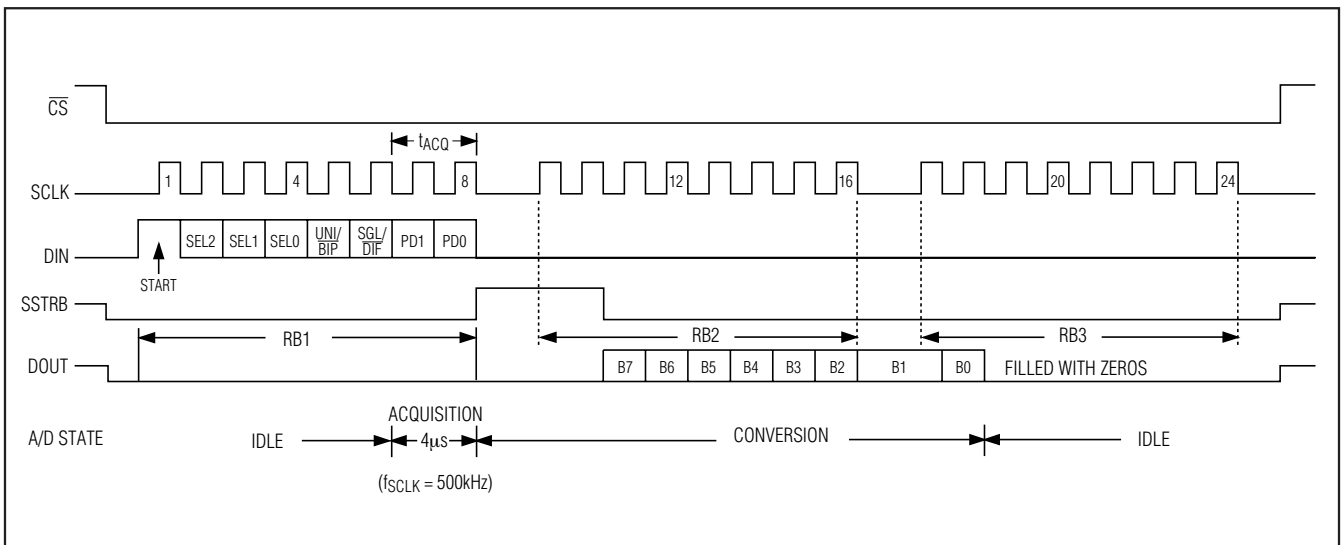

Figure 7. Single-Conversion Timing, External Clock Mode, 24 Clocks

# +2.7V, Low-Power, Multichannel, Serial 8-Bit ADCs

### Digital Output

In unipolar input mode, the output is straight binary (Figure 15). For bipolar inputs, the output is two's-complement (Figure 16). Data is clocked out at SCLK's falling edge in MSB-first format.

### Clock Modes

The MAX1110/MAX1111 can use either an external serial clock or the internal clock to perform the successive-approximation conversion. In both clock modes, the external clock shifts data in and out of the devices. Bit PDO of the control byte programs the clock mode. Figures 8–11 show the timing characteristics common to both modes.

### External Clock

In external clock mode, the external clock not only shifts data in and out, it also drives the analog-to-digital

conversion steps. SSTRB pulses high for two clock periods after the last bit of the control byte. Successive-approximation bit decisions are made and appear at DOUT on each of the next eight SCLK falling edges (Figure 7). After the eight data bits are clocked out, subsequent clock pulses clock out zeros from the DOUT pin.

SSTRB and DOUT go into a high-impedance state when  $\overline{CS}$  goes high; after the next  $\overline{CS}$  falling edge, SSTRB outputs a logic low. Figure 9 shows the SSTRB timing in external clock mode.

The conversion must complete in 1ms, or droop on the sample-and-hold capacitors can degrade conversion results. Use internal clock mode if the serial-clock frequency is less than 50kHz, or if serial-clock interruptions could cause the conversion interval to exceed 1ms.

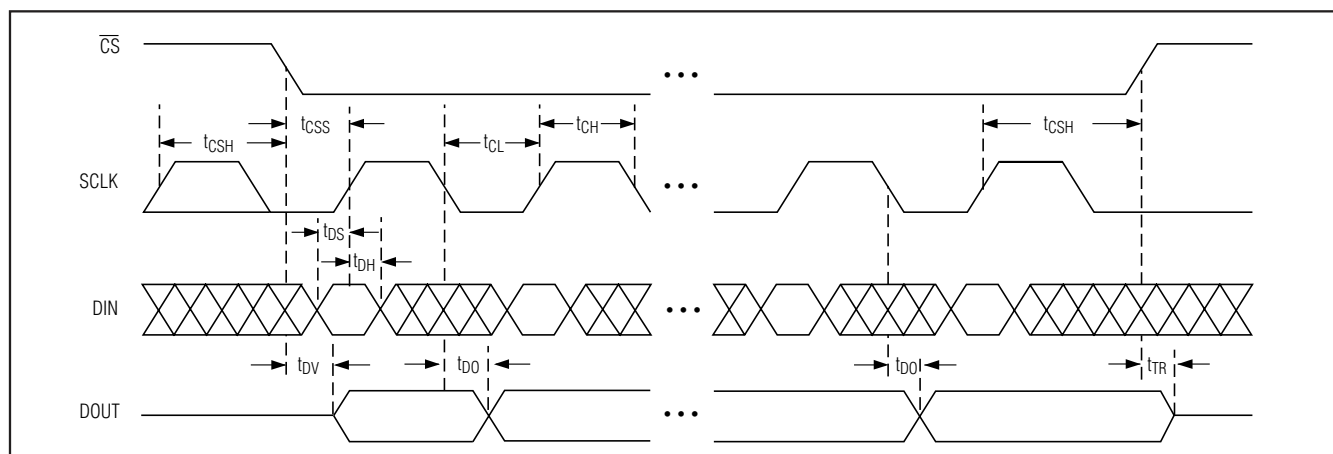

Figure 8. Detailed Serial-Interface Timing

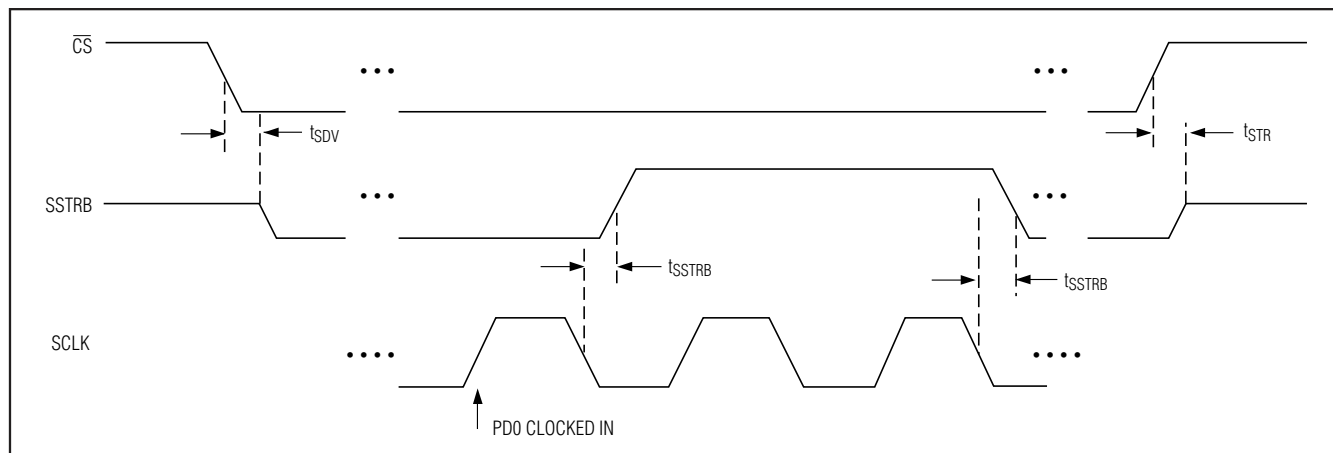

Figure 9. External Clock Mode SSTRB Detailed Timing

# +2.7V, Low-Power, Multichannel, Serial 8-Bit ADCs

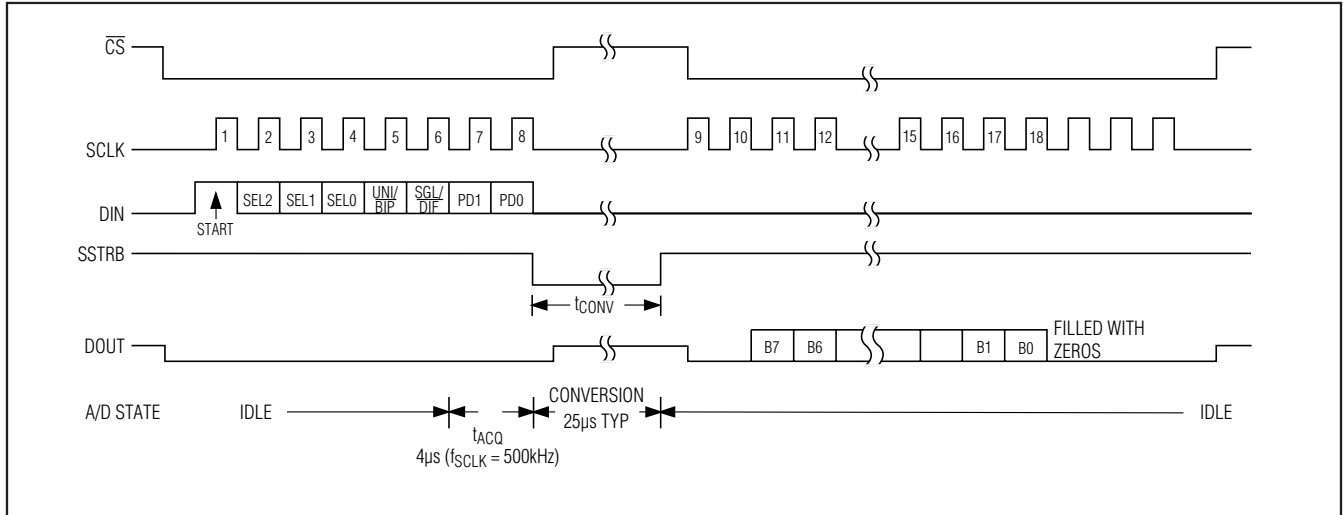

Figure 10. Internal Clock Mode Timing

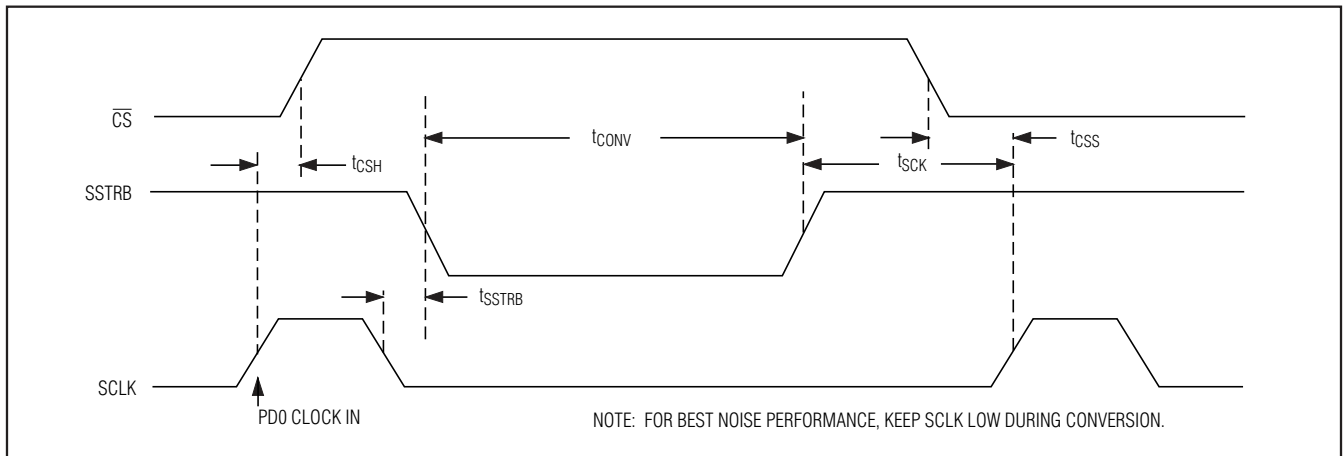

Figure 11. Internal Clock Mode SSTRB Detailed Timing

### Internal Clock

Internal clock mode frees the  $\mu\text{P}$  from the burden of running the SAR conversion clock. This allows the conversion results to be read back at the processor's convenience, at any clock rate up to 2MHz. SSTRB goes low at the start of the conversion and then goes high when the conversion is complete. SSTRB is low for 25 $\mu\text{s}$  (typ), during which time SCLK should remain low for best noise performance.

An internal register stores data when the conversion is in progress. SCLK clocks the data out of this register at any time after the conversion is complete. After SSTRB goes high, the second falling clock edge produces the MSB of the conversion at DOUT, followed by the

remaining bits in MSB-first format (Figure 10).  $\overline{\text{CS}}$  does not need to be held low once a conversion is started. Pulling  $\overline{\text{CS}}$  high prevents data from being clocked into the MAX1110/MAX1111 and three-states DOUT, but it does not adversely affect an internal clock-mode conversion already in progress. When internal clock mode is selected, SSTRB does not go into a high-impedance state when  $\overline{\text{CS}}$  goes high.

Figure 11 shows the SSTRB timing in internal clock mode. In this mode, data can be shifted in and out of the MAX1110/MAX1111 at clock rates up to 2MHz, provided that the minimum acquisition time,  $t_{\text{ACQ}}$ , is kept above 1 $\mu\text{s}$ .

# +2.7V, Low-Power, Multichannel, Serial 8-Bit ADCs

MAX1110/MAX1111

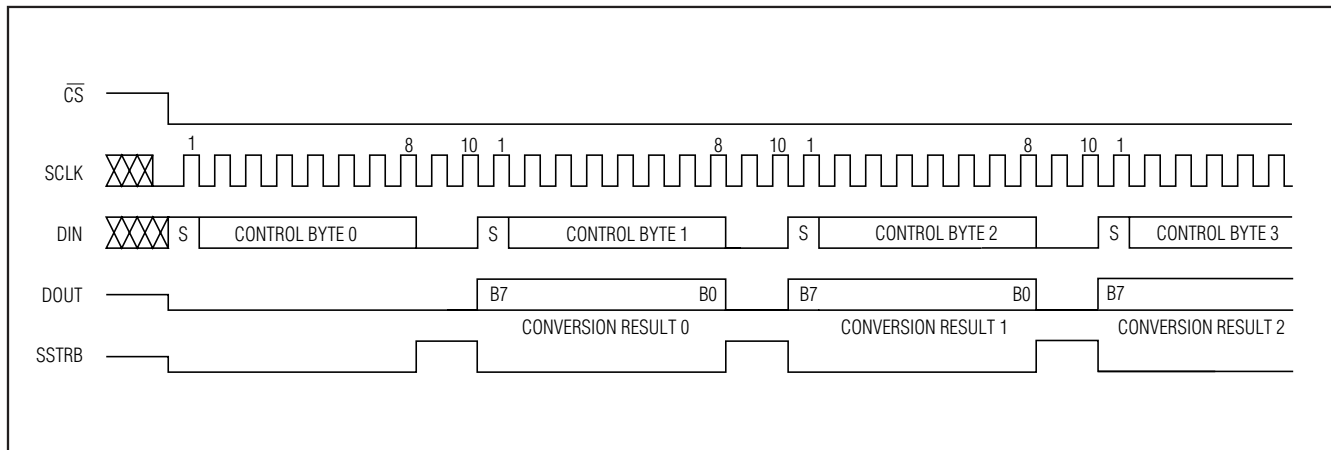

Figure 12a. Continuous Conversions, External Clock Mode, 10 Clocks/Conversion Timing

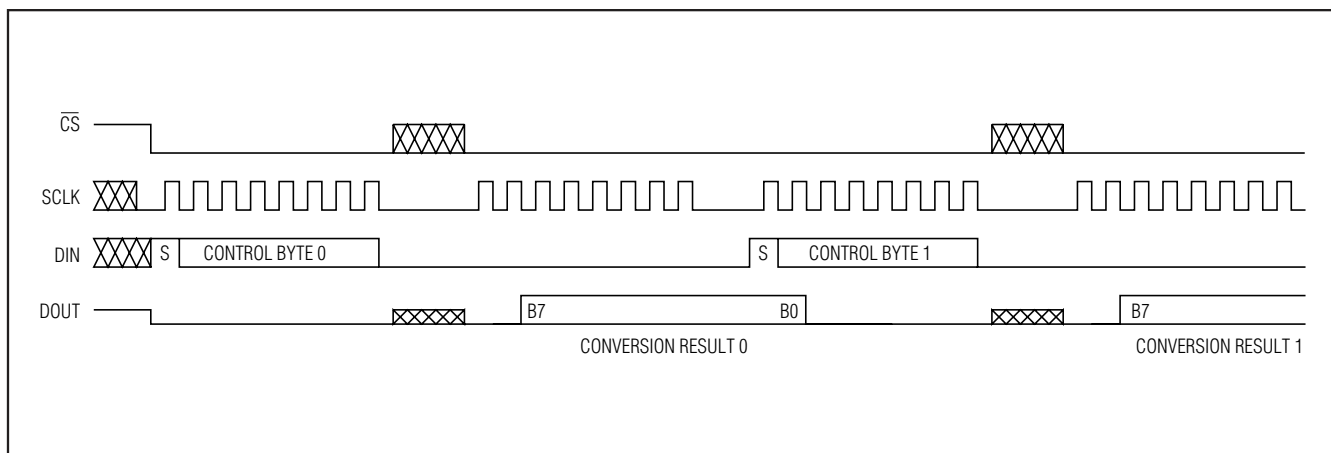

Figure 12b. Continuous Conversions, External Clock Mode, 16 Clocks/Conversion Timing

### Data Framing

The falling edge of  $\overline{CS}$  does not start a conversion. The first logic high clocked into DIN is interpreted as a start bit and defines the first bit of the control byte. A conversion starts on the falling edge of SCLK, after the eighth bit of the control byte (the P0 bit) is clocked into DIN. The start bit is defined as:

The first high bit clocked into DIN with  $\overline{CS}$  low any time the converter is idle; e.g., after  $V_{DD}$  is applied.

OR

The first high bit clocked into DIN after the MSB of a conversion in progress is clocked onto the DOUT pin.

If  $\overline{CS}$  is toggled before the current conversion is complete, then the next high bit clocked into DIN is recognized as a start bit; the current conversion is terminated, and a new one is started.

The fastest the MAX1110/MAX1111 can run is 10 clocks per conversion. Figure 12a shows the serial-interface timing necessary to perform a conversion every 10 SCLK cycles in external clock mode.

Many microcontrollers require that conversions occur in multiples of eight SCLK clocks; 16 clocks per conversion is typically the fastest that a microcontroller can drive the MAX1110/MAX1111. Figure 12b shows the serial-interface timing necessary to perform a conversion every 16 SCLK cycles in external clock mode.

# +2.7V, Low-Power, Multichannel, Serial 8-Bit ADCs

## Applications Information

### Power-On Reset

When power is first applied, and if  $\overline{\text{SHDN}}$  is not pulled low, internal power-on reset circuitry activates the MAX1110/MAX1111 in internal clock mode.  $\text{SSTRB}$  is high on power-up and, if  $\overline{\text{CS}}$  is low, the first logical 1 on  $\text{DIN}$  is interpreted as a start bit. Until a conversion takes place,  $\text{DOUT}$  shifts out zeros. No conversions should be performed until the reference voltage has stabilized (see *Electrical Characteristics*).

### Power-Down

When operating at speeds below the maximum sampling rate, the MAX1110/MAX1111's automatic power-down mode can save considerable power by placing the converters in a low-current shutdown state between conversions. Figure 13 shows the average supply current as a function of the sampling rate.

Select power-down with PD1 of the  $\text{DIN}$  control byte with  $\overline{\text{SHDN}}$  high or high impedance (Table 3). Pull  $\overline{\text{SHDN}}$  low at any time to shut down the converters completely.  $\overline{\text{SHDN}}$  overrides PD1 of the control byte. Figures 14a and 14b illustrate the various power-down sequences in both external and internal clock modes.

### Software Power-Down

Software power-down is activated using bit PD1 of the control byte. When software power-down is asserted, the ADCs continue to operate in the last specified clock mode until the conversion is complete. The ADCs then power down into a low quiescent-current state. In internal clock mode, the interface remains active, and conversion results can be clocked out after the MAX1110/MAX1111 have entered a software power-down.

The first logical 1 on  $\text{DIN}$  is interpreted as a start bit, which powers up the MAX1110/MAX1111. If the  $\text{DIN}$  byte contains PD1 = 1, then the chip remains powered up. If PD1 = 0, power-down resumes after one conversion.

**Table 5. Hard-Wired Power-Down and Internal Reference State**

$\overline{\text{SHDN}}$ STATE	DEVICE MODE	INTERNAL REFERENCE
1	Enabled	Disabled
High Impedance	Enabled	Enabled
0	Power-Down	Disabled

### Hard-Wired Power-Down

Pulling  $\overline{\text{SHDN}}$  low places the converters in hard-wired power-down. Unlike software power-down, the conversion is not completed; it stops coincidentally with  $\overline{\text{SHDN}}$  being brought low.  $\overline{\text{SHDN}}$  also controls the state of the internal reference (Table 5). Letting  $\overline{\text{SHDN}}$  high impedance enables the internal 2.048V voltage reference. When returning to normal operation with  $\overline{\text{SHDN}}$  high impedance, there is a  $\text{TRC}$  delay of approximately  $1\text{M}\Omega \times C_{\text{LOAD}}$ , where  $C_{\text{LOAD}}$  is the capacitive loading on the  $\overline{\text{SHDN}}$  pin. Pulling  $\overline{\text{SHDN}}$  high disables the internal reference, which saves power when using an external reference.

### External Reference

An external reference between 1V and  $V_{\text{DD}}$  should be connected directly at the  $\text{REFIN}$  terminal. The DC input impedance at  $\text{REFIN}$  is extremely high, consisting of leakage current only (typically 10nA). During a conversion, the reference must be able to deliver up to 20 $\mu\text{A}$  average load current and have an output impedance of 1k $\Omega$  or less at the conversion clock frequency. If the reference has higher output impedance or is noisy, bypass it close to the  $\text{REFIN}$  pin with a 0.1 $\mu\text{F}$  capacitor.

If an external reference is used with the MAX1110/MAX1111, connect  $\overline{\text{SHDN}}$  to  $V_{\text{DD}}$  to disable the internal reference and decrease power consumption.

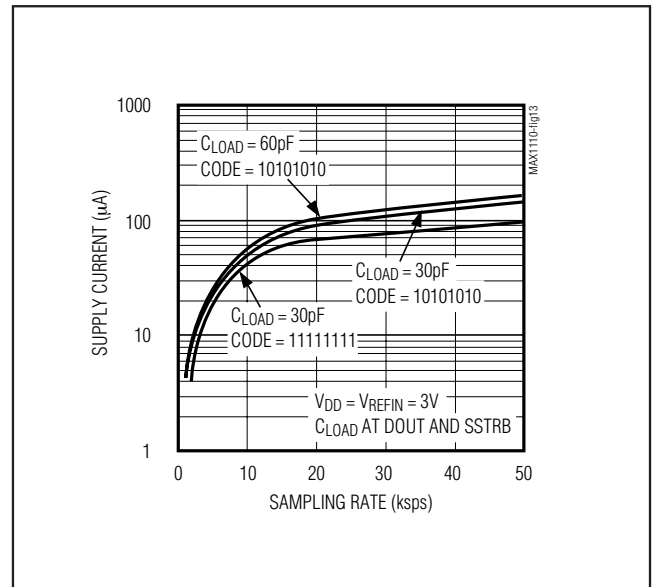

Figure 13. Average Supply Current vs. Sampling Rate



# +2.7V, Low-Power, Multichannel, Serial 8-Bit ADCs

MAX1110/MAX1111

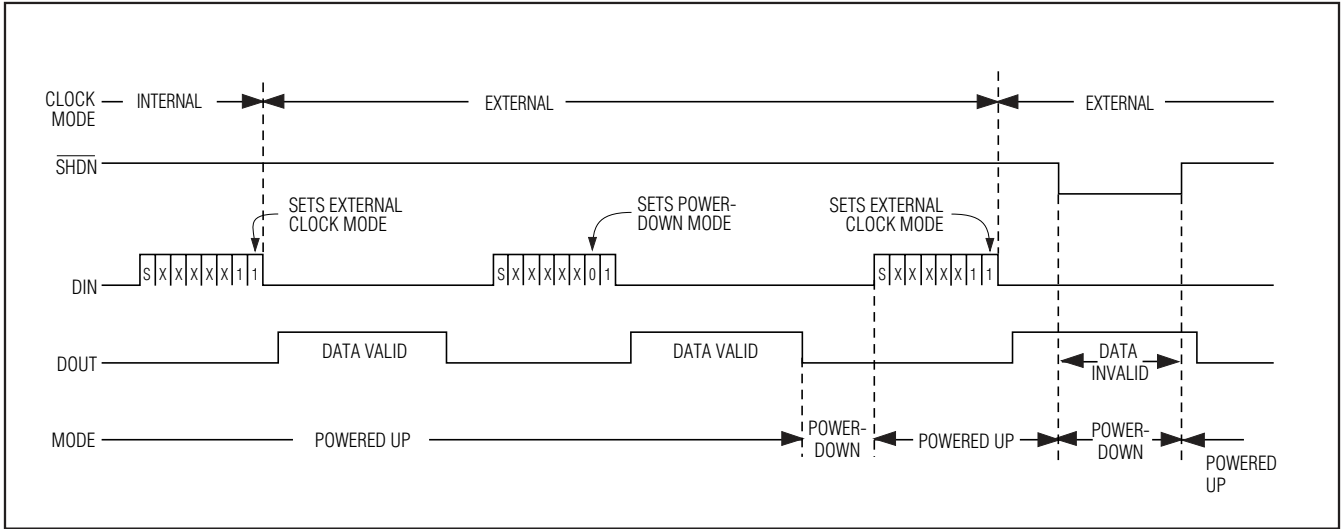

Figure 14a. Power-Down Modes, External Clock Timing Diagram

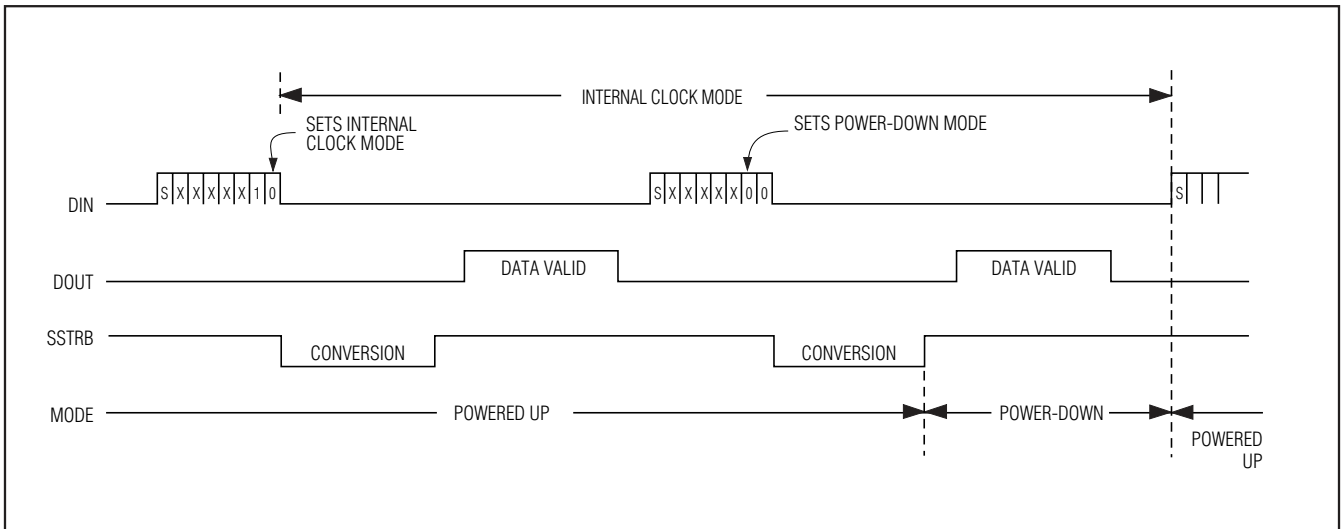

Figure 14b. Power-Down Modes, Internal Clock Timing Diagram

### Internal Reference

To use the MAX1110/MAX1111 with the internal reference, connect REFIN to REFOUT. The full-scale range of the MAX1110/MAX1111 with the internal reference is typically 2.048V with unipolar inputs, and  $\pm 1.024V$  with bipolar inputs. The internal reference should be bypassed to AGND with a  $1\mu F$  capacitor placed as close to the REFIN pin as possible.

### Transfer Function

Table 4 shows the full-scale voltage ranges for unipolar and bipolar modes. Figure 15 depicts the nominal, unipolar I/O transfer function, and Figure 16 shows the bipolar I/O transfer function when using a 2.048V reference. Code transitions occur at integer LSB values. Output coding is binary, with  $1 \text{ LSB} = 8mV$  ( $2.048V/256$ ) for unipolar operation and  $1 \text{ LSB} = 8mV$  [ $(2.048V/2 - -2.048V/2)/256$ ] for bipolar operation.

# +2.7V, Low-Power, Multichannel, Serial 8-Bit ADCs

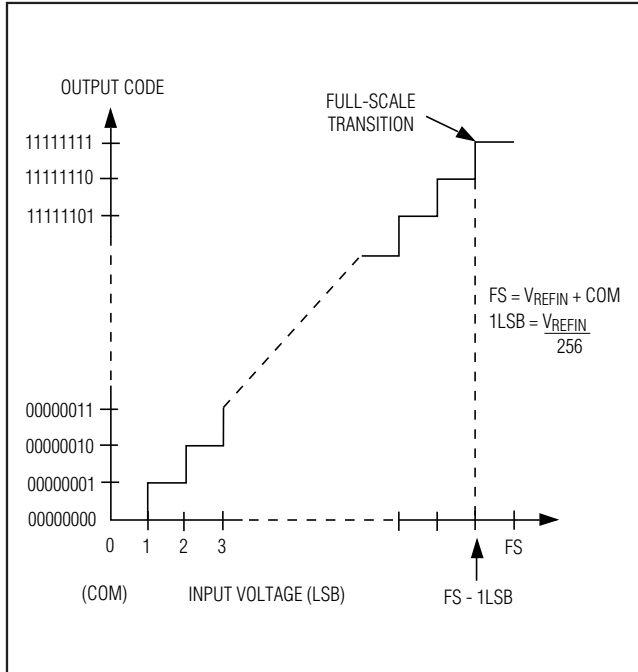

Figure 15. Unipolar Transfer Function

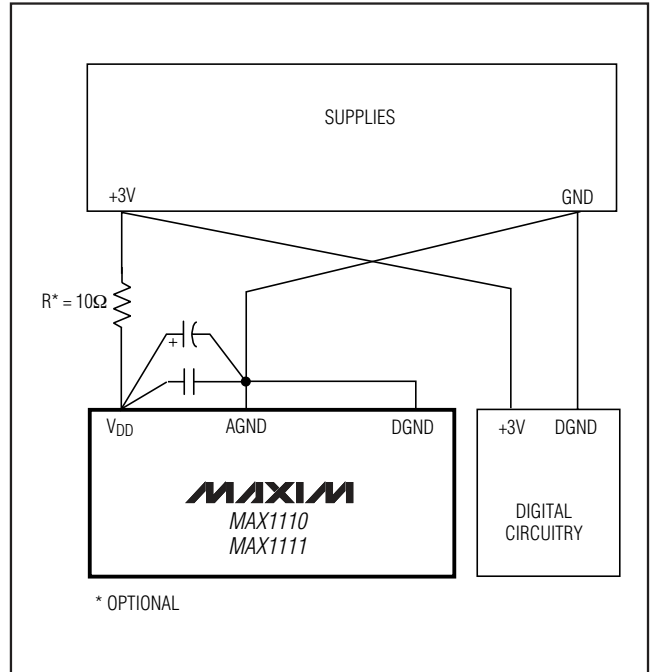

Figure 17. Power-Supply Grounding Connections

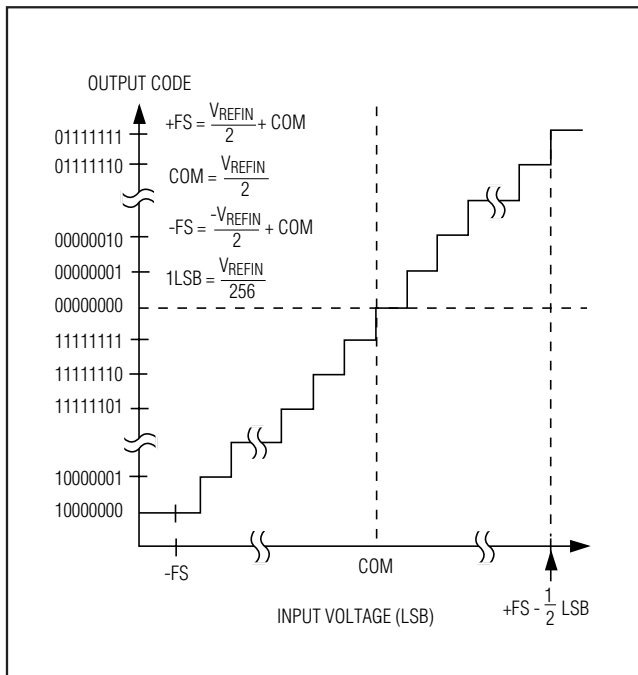

Figure 16. Bipolar Transfer Function

## Layout, Grounding, and Bypassing

For best performance, use printed circuit boards. Wire-wrap boards are not recommended. Board layout should ensure that digital and analog signal lines are separated from each other. Do not run analog and digital (especially clock) lines parallel to one another, or digital lines underneath the ADC package.

Figure 17 shows the recommended system ground connections. A single-point analog ground (star ground point) should be established at AGND, separate from the logic ground. Connect all other analog grounds and DGND to the star ground. No other digital system ground should be connected to this ground. The ground return to the power supply for the star ground should be low impedance and as short as possible for noise-free operation.

High-frequency noise in the VDD power supply can affect the comparator in the ADC. Bypass the supply to the star ground with 0.1μF and 1μF capacitors close to the VDD pin of the MAX1110/MAX1111. Minimize capacitor lead lengths for best supply-noise rejection. If the +3V power supply is very noisy, a 10Ω resistor can be connected to form a lowpass filter.

# +2.7V, Low-Power, Multichannel, Serial 8-Bit ADCs

## Pin Configurations

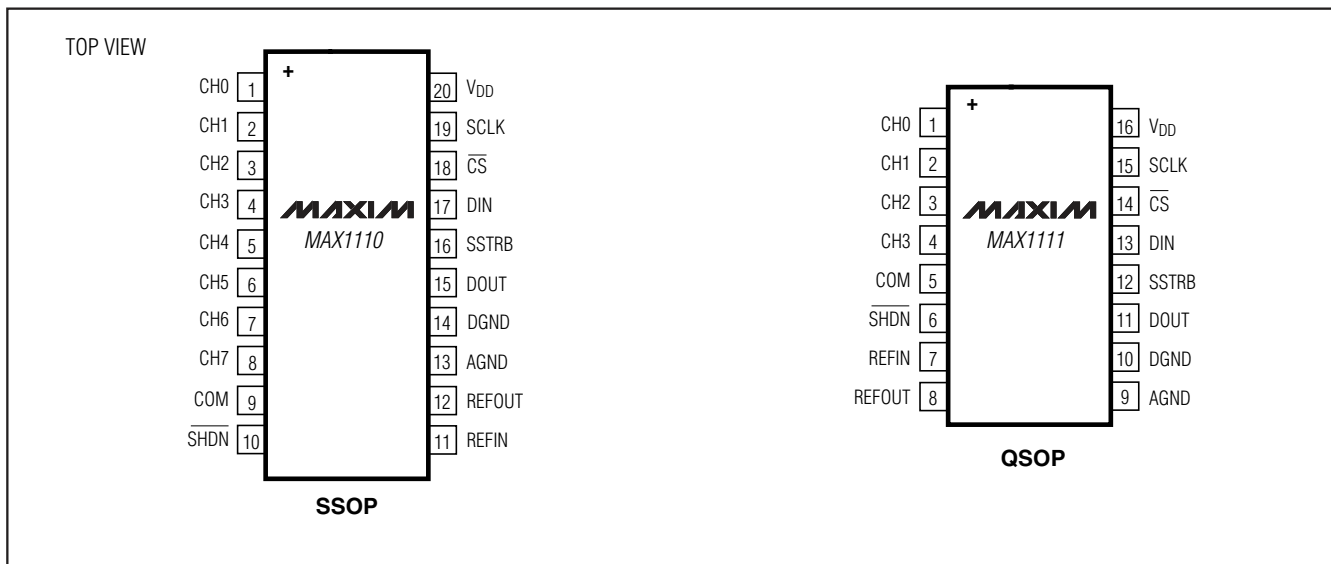

MAX1110/MAX1111

## Ordering Information

PART	TEMP RANGE	PIN-PACKAGE
MAX1110CAP+	0°C to +70°C	20 SSOP
MAX1110C/D	0°C to +70°C	Dice*
MAX1110EAP+	-40°C to +85°C	20 SSOP
MAX1111CEE+	0°C to +70°C	16 QSOP
MAX1111EEE+	-40°C to +85°C	16 QSOP
MAX1111EEE/V+	-40°C to +85°C	16 QSOP

\*Dice are specified at  $T_A = +25^\circ\text{C}$ , DC parameters only.

+Denotes a lead(Pb)-free/RoHS-compliant package.

/V denotes an automotive qualified part.

## Chip Information

PROCESS: CMOS

SUBSTRATE CONNECTED TO DGND

## Package Information

For the latest package outline information and land patterns (footnote), go to [www.maxim-ic.com/packages](http://www.maxim-ic.com/packages). Note that a "+", "#", or "-" in the package code indicates RoHS status only. Package drawings may show a different suffix character, but the drawing pertains to the package regardless of RoHS status.

PACKAGE TYPE	PACKAGE CODE	OUTLINE NO.	LAND PATTERN NO.
20 SSOP	A20+1	<a href="#">21-0056</a>	<a href="#">90-0094</a>
16 QSOP	E16+1	<a href="#">21-0055</a>	<a href="#">90-0167</a>

# +2.7V, Low-Power, Multichannel, Serial 8-Bit ADCs

## Revision History

REVISION NUMBER	REVISION DATE	DESCRIPTION	PAGES CHANGED
3	2/10	Added automotive qualified part to data sheet	19
4	4/11	Removed PDIP packages from data sheet. Revised <i>Timing Characteristics</i> table and included style updates throughout data sheet.	1-7, 10, 13, 14, 16, 18, 19

Maxim cannot assume responsibility for use of any circuitry other than circuitry entirely embodied in a Maxim product. No circuit patent licenses are implied. Maxim reserves the right to change the circuitry and specifications without notice at any time.

20 \_\_\_\_\_ **Maxim Integrated Products, 120 San Gabriel Drive, Sunnyvale, CA 94086 408-737-7600**