

THE INFORMATION CONTAINED HEREIN IS CONSIDERED "PROPRIETARY" TO BEL FUSE INC. AND SHALL NOT BE COPIED, REPRODUCED OR DISCLOSED WITHOUT THE WRITTEN APPROVAL OF BEL FUSE INC.

RoHS



| LED1 POLARITY | | | LED2 POLARITY | | |
|---------------|--------|--------|---------------|--------|-------|
| PIN 13 | PIN 14 | COLOR | PIN 15 | PIN 16 | COLOR |
| - | + | YELLOW | - | + | GREEN |

ELECTRICAL CHARACTERISTICS @ 25°C

URNS RATIO

| | | |
|-----|-----------|-----|
| TP1 | 1CT : 1CT | ±2% |
| TP2 | 1CT : 1CT | ±2% |
| TP3 | 1CT : 1CT | ±2% |
| TP4 | 1CT : 1CT | ±2% |

OCL @ 100kHz/100mVRMS

8mA DC BIAS 350 μH MIN.

INS. LOSS

| | |
|------------------|-------------|
| 0.1MHz TO 1MHz | -1.1 dB MAX |
| 1MHz TO 65MHz | -0.5 dB MAX |
| 65MHz TO 100MHz | -0.8 dB MAX |
| 100MHz TO 125MHz | -1.2 dB MAX |

RET. LOSS (MIN)

| | |
|--------------|-----------------------|
| 0.5MHz-40MHz | -18 dB |
| 40MHz-100MHz | -12+20LOG(f/80MHz) dB |

CM TO CM REJ

100kHz - 100MHz -30 dB MIN

CM TO DM REJ

100kHz - 100MHz -35 dB MIN

HIPOT (Isolation Voltage): 1500 Vrms or 2250VDC

100% OF PRODUCTION TESTED TO COMPLY WITH IEEE 802.3 ISOLATION REQUIREMENTS.

LED 1

V_F (FORWARD VOLTAGE) IF=20mA YELLOW 2.1V TYP.
 λ_D (DOMINANT WAVELENGTH) IF=20mA YELLOW 590nm TYP.

LED 2

V_F (FORWARD VOLTAGE) IF=20mA GREEN 2.2V TYP.
 λ_D (DOMINANT WAVELENGTH) IF=20mA GREEN 570nm TYP.

OPERATING TEMPERATURE: 0°C TO +70°C.

SCHEMATIC

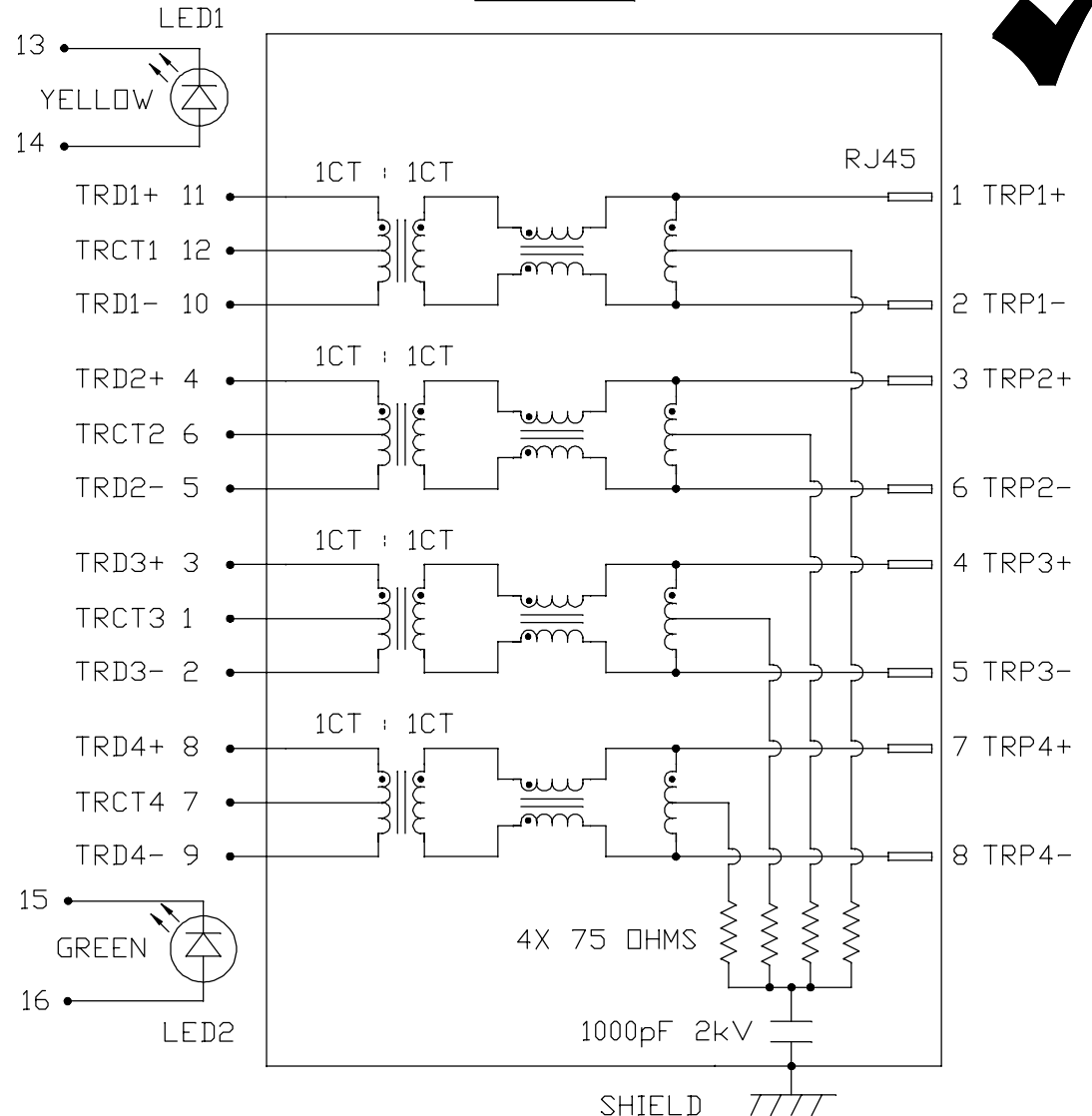

ORIGINATED BY
CHOW WANCHUNG
DATE 2016-08-10

TITLE
Gigabit MagJack®
(12 cores, Tab Up)
0826-1A1T-23-F

PART NO. / DRAWING NO.
08261A1T23-F

FILE NAME
08261A1T23-F_F.DWG

| | |
|-------------------------------|----------------------------|
| STANDARD DIM. TOL. IN INCH | [] METRIC DIM. AS REF. |
| .X | UNIT : INCH [mm] |
| .XX | SCALE : N/A |
| .XXX | SIZE : A4 |

REV. : F PAGE : 2



THE INFORMATION CONTAINED HEREIN IS CONSIDERED "PROPRIETARY" TO BEL FUSE INC. AND SHALL NOT BE COPIED, REPRODUCED OR DISCLOSED WITHOUT THE WRITTEN APPROVAL OF BEL FUSE INC.

MECHANICAL SPECIFICATION

RoHS

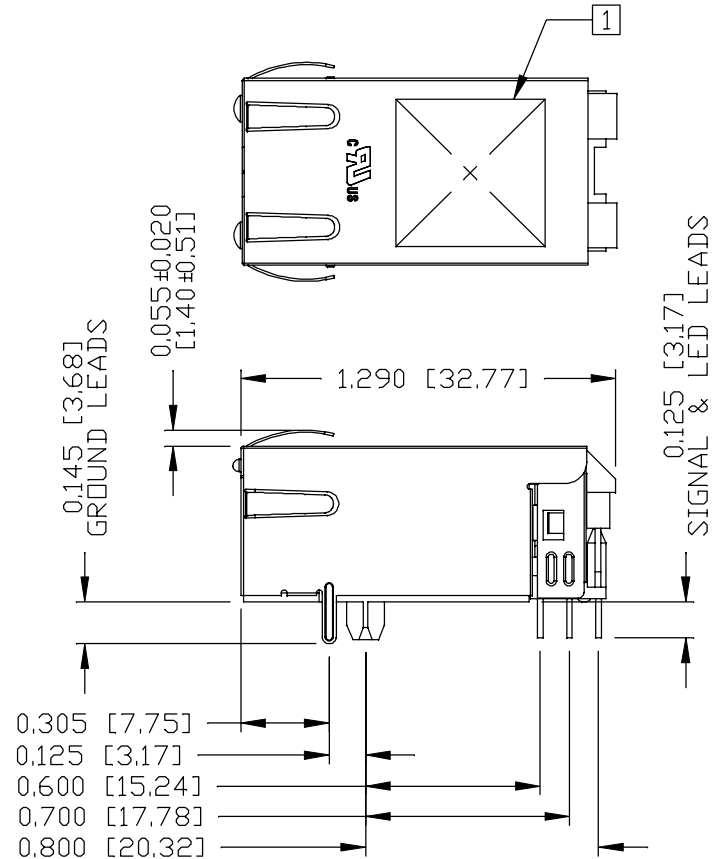
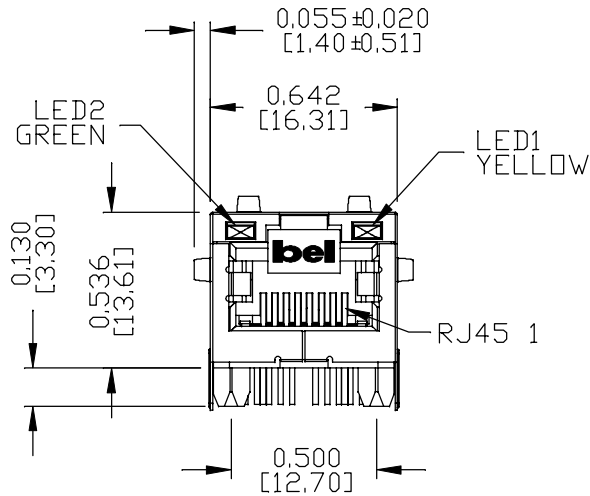

NOTES:

- PLASTIC HOUSING: THERMOPLASTIC PA, BLACK
FLAMMABILITY RATING UL 94V-0
- CONTACTS: 50 MICRO-INCH HARD GOLD PLATING OR EQUIVALENT,
30 MICRO-INCH MIN NICKEL UNDERPLATE.
- OUTPUT PINS: TIN-COATED COPPER WIRE, DIA 0.018 INCH,
100 MICRO-INCH MIN MATTE TIN. PINS ARE SOLDER DIPPED.
- METAL SHIELD: NICKEL PLATED ON COPPER ALLOY.
(ALL GROUND LEADS ARE SOLDER DIPPED)

① MARK PART WITH MFG LOGO, MFG NAME, PART NUMBER, DATE CODE.

c RoHS UL RECOGNIZED - FILE #E196366 AND E169987.

2. THE PRODUCT IS RoHS COMPLIANT.

3. JACK CAVITY CONFORMS TO FCC RULES AND REGULATIONS.

4. THE PART IS RECOMMENDED FOR WAVE SOLDERING. THE SUGGESTED PEAK WAVE SOLDERING CONDITION IS 260°C MAX AND 10 SECONDS MAX.

| | | | | | | | | | | | |
|--|--|---|--|--|--|-------------------------------|--|----------------------------|--|---|----------|
| ORIGINATED BY ANTON LIAO DATE 2016-08-10 | | TITLE Gigabit MagJack® (12 cores, Tab Up) 0826-1A1T-23-F | | PART NO. / DRAWING NO. 08261A1T23-F | | STANDARD DIM. TOL. IN INCH | | [] METRIC DIM. AS REF. | | REV. : F | PAGE : 3 |
| DRAWN BY JESSE LI DATE 2016-08-10 | | FILE NAME 08261A1T23-F_F.DWG | | .X | | UNIT : INCH [mm] | | SCALE : N/A | |  | |
| | | | | .XX | | SIZE : A4 | | | | | |
| | | | | .XXX | | ±0.010 | | | | | |

THE INFORMATION CONTAINED HEREIN IS CONSIDERED "PROPRIETARY" TO BEL FUSE INC. AND SHALL NOT BE COPIED, REPRODUCED OR DISCLOSED WITHOUT THE WRITTEN APPROVAL OF BEL FUSE INC.

RoHS



RECOMMENDED PCB FOOTPRINT

COMPONENT SIDE VIEW

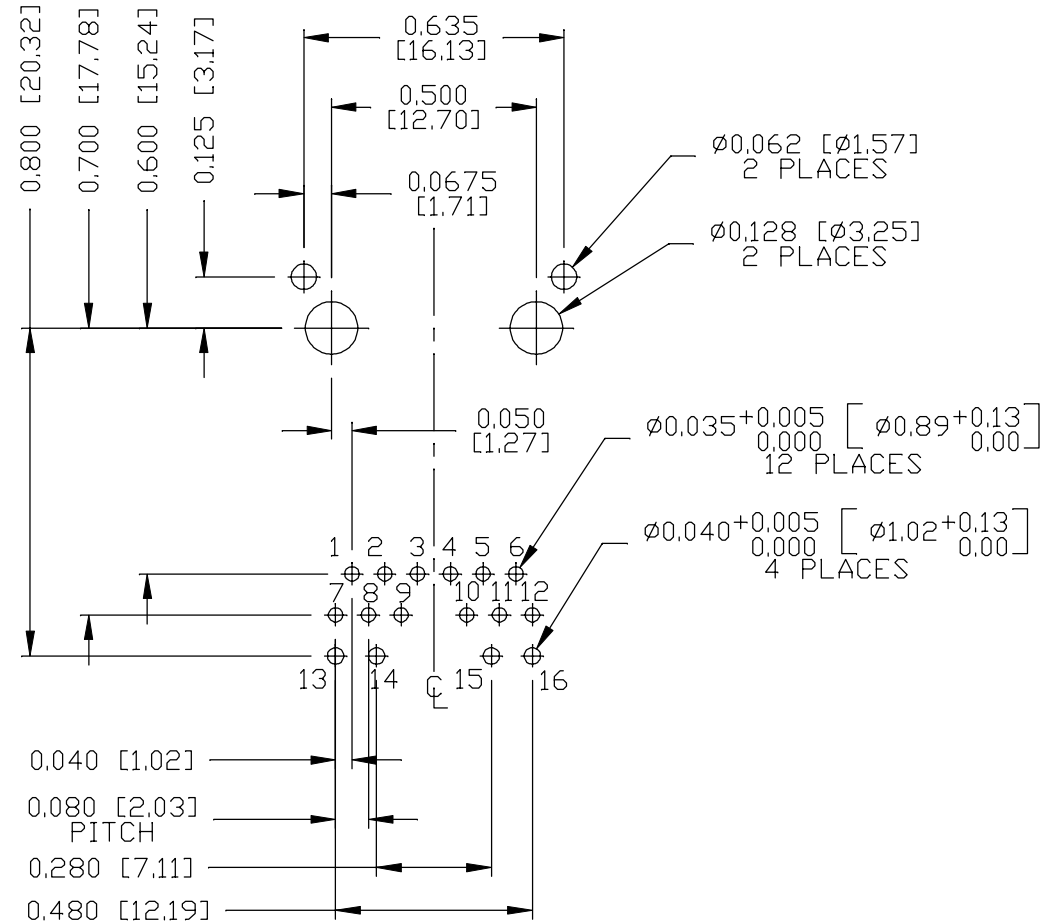
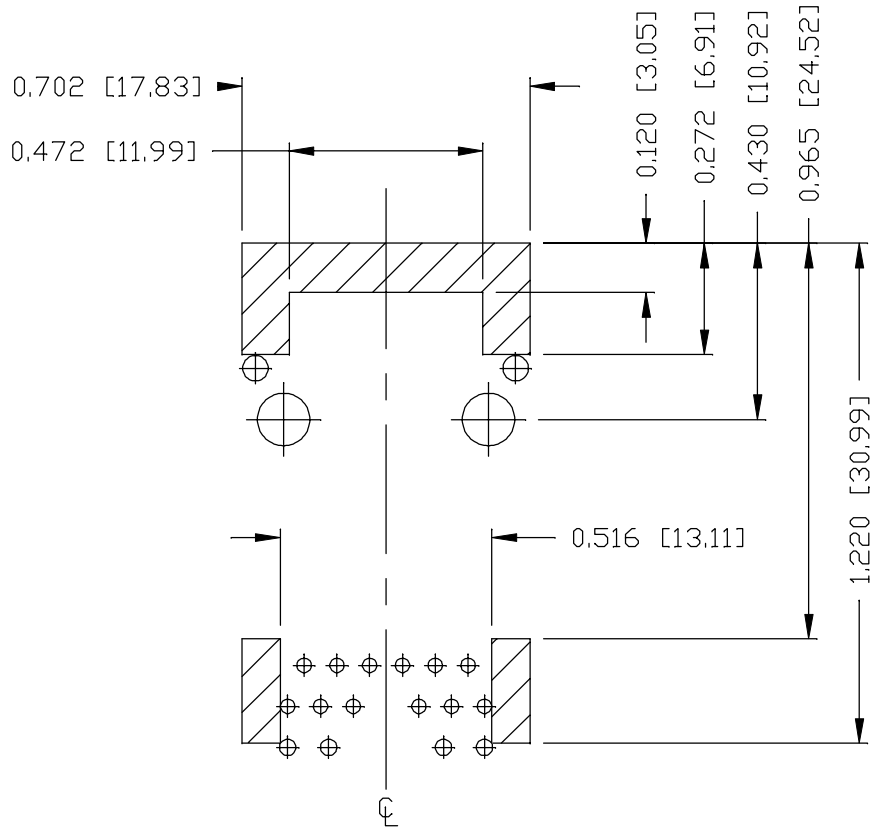

NOTES

THE SHADED AREA ON THE CUSTOMER BOARD ARE RECOMMENDED TO BE CLEAR OFF ANY VIA HOLE OR COMPONENT PAD.

REV. : F PAGE : 4

ORIGINATED BY
ANTON LIAO
DATE 2016-08-10
DRAWN BY
JESSE LI
DATE 2016-08-10

TITLE
Gigabit MagJack®
(12 cores, Tab Up)
0826-1A1T-23-F

PART NO. / DRAWING NO.
08261A1T23-F
FILE NAME
08261A1T23-F_F.DWG

| | |
|-------------------------------|----------------------------|
| STANDARD DIM. TOL. IN INCH | [] METRIC DIM. AS REF. |
| .X | UNIT : INCH [mm] |
| .XX | SCALE : N/A |
| .XXX ±0.004 | SIZE : A4 |



THE INFORMATION CONTAINED HEREIN IS CONSIDERED "PROPRIETARY" TO BEL FUSE INC. AND SHALL NOT BE COPIED, REPRODUCED OR DISCLOSED WITHOUT THE WRITTEN APPROVAL OF BEL FUSE INC.

RoHS



SUGGESTED PANEL OPENING

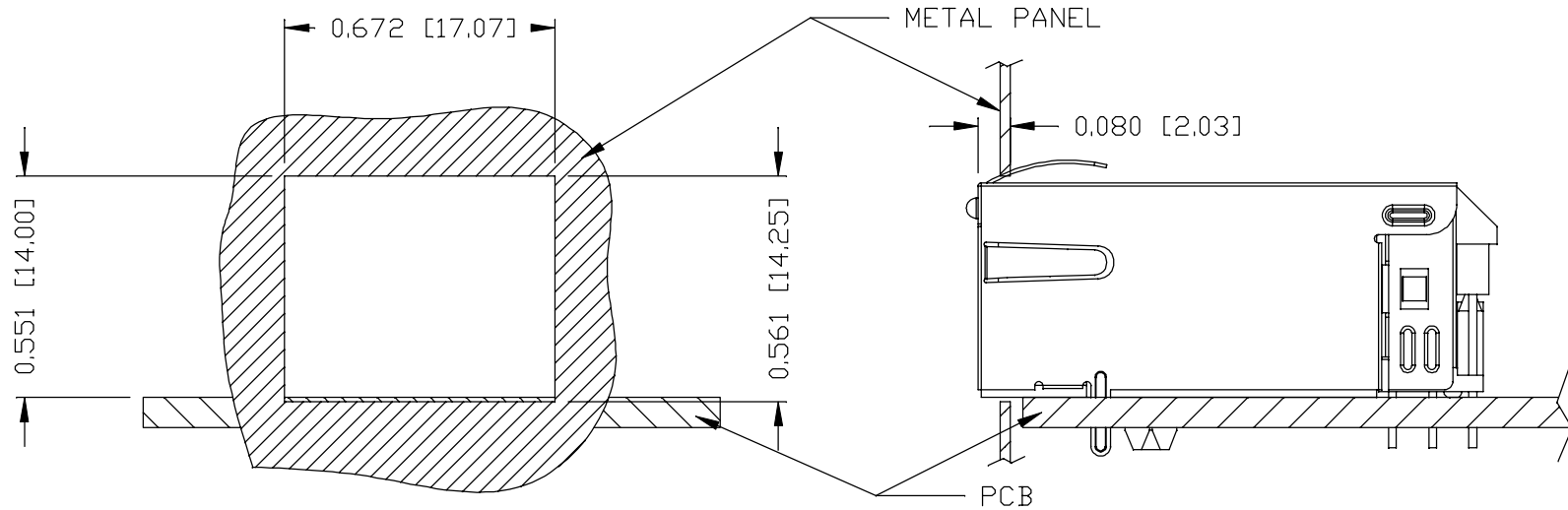

NOTE:

THE DISTANCE OF PANEL INSIDE SURFACE RELATIVE TO FRONT SURFACE OF PART IS ONLY A SUGGESTION. IN CASE THIS DISTANCE IS DIFFERENT, THE REQUIRED PANEL OPENING DIMENSIONS CHANGE ACCORDINGLY.

PACKING INFORMATION

PACKING TRAY : 0200-9999-F6 (TOP)

0200-9999-F7 (BOTTOM)

PACKING QUANTITY : 40 PCS FINISHED GOODS PER TRAY

10 TRAYS (400 PCS FINISHED GOODS) PER CARTON BOX

NOTE : CARDBOARDS ARE PLACED BETWEEN LAYERS OF PACKING TRAY INSIDE CARTON BOX (INCLUDE THE UPPERMOST AND LOWERMOST TRAY)

| | | | |
|--------|---|--------|---|
| REV. : | F | PAGE : | 5 |
|--------|---|--------|---|

| | | | | |
|---|--|---|--|---|
| ORIGINATED BY ANTON LIAO DATE 2016-08-10 DRAWN BY JESSE LI DATE 2016-08-10 | TITLE Glgabit MagJack® (12 cores, Tab Up) 0826-1A1T-23-F | PART NO. / DRAWING NO. 08261A1T23-F | STANDARD DIM. TOL. IN INCH .X | <input type="checkbox"/> METRIC DIM. AS REF. |
| | | FILE NAME 08261A1T23-F_F.DWG | .XX | UNIT : INCH [mm] SCALE : N/A |
| | | .XXX | ±0.004 | <input checked="" type="checkbox"/> SIZE : A4 |

