

APPROVAL SHEET

Dipole ANTENNA
433MHz Working Frequency
Halogens Free Product
P/N: RFDPA131000SBUB802

Customer : _____
Customer 's Part No. : _____
Approval No. : _____
Issue Date : _____

*Contents in this sheet are subject to change without prior notice.

Version	Date	Description	Author
V01	2017 Feb.	New Release	SHLEE

ELECTRICAL CHARACTERISTICS

Item	Specification
Frequency Range	433 MHz(note-1)
Impedance	50 Ohm Nominal
VSWR	2 Max.
Radiation	Omni-directional
Gain(peak)	1.3dBi
Polarization	Linear Vertical
Admitted Power	1W

*note-1: Electrical characteristics will depend on customer's final application.

MATERIAL TABLE

Items	Description
Cable	RG178(Brown)
Antenna Cover	ABS(Black)
Antenna Base	PC+PBT(Black)
Connector	Reverse SMA Plug(Black)
PCB	FR4
Sponge	Black

ORDERING RULE

RF	DPA	1310	00	S	B	U	B	8	02
Type Code	Product Code	Dipole Dimension (Unit: mm)	Cable Length (unit: cm)	Connector Brand	Type of Connector	Application	Project status	Wire Diameter	Project
Walsin RF Device	DPA: Dipole Antenna	Per 2 digits of length, width e.g.: 1510 Length 150.8mm, Width 10mm	2 digits for cable length e.g.: 00 None Cable	A: N C:MCX D:IPEX III E: IPEX IV F: IPEX A13 H: Hirose I: IPEX M: MMCX S: SMA T: TNC U:MURATA N: None	A: Reverse Female B: Reverse Male F: Female M: Male N: None	0: 0GHz 3: 3GHz 6: 6GHz A: 2.4GHz ISM band B: GSM 900/1800 dual band G: GPS band L: 2.4/5.2/5.8 GHz tri-band N: NFC T: LTE band W: WCDMA band	B: MP T:Durin g Test X: Pile Run	0:None 1:∅ 0.81 3:∅ 1.13 6:RG316 7:∅ 1.37 8:RG178	01~99 series number

DIMENSIONS

ELECTRICAL
Frequency: 433 MHz

No.	DESCRIPTION	MAT'L	Color	Q'TY
A	Antenna Cover	ABS	Black	1
B	Antenna Base	PC+PBT	Black	1
C	Connector	Reverse SMA Plug	Brass	Black
D	Cable	RG178	—	Brown
E	PCB	RFPCA1109-06_Rev01	FR4	—
F	Sponge	—	Black	1

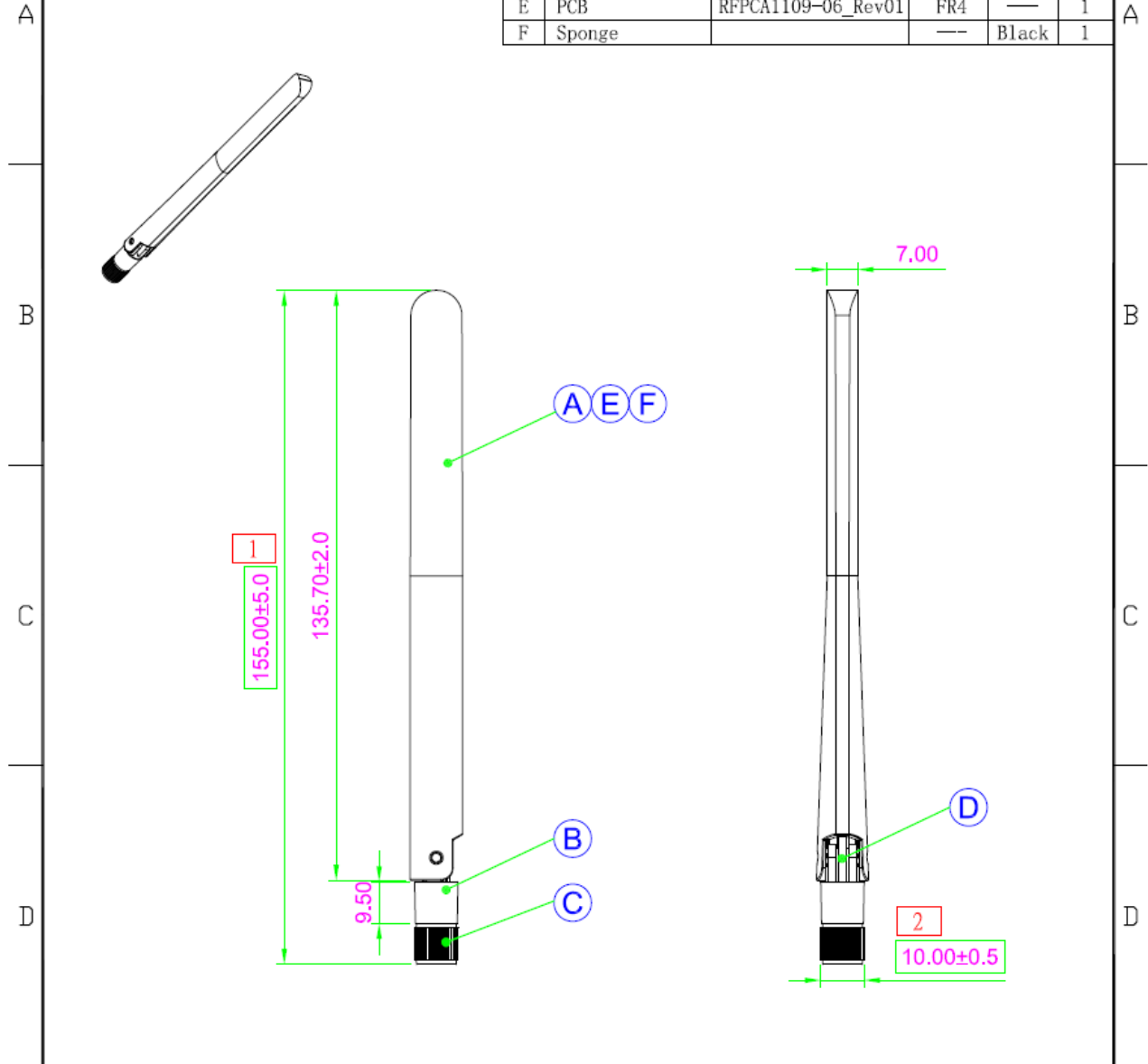

※標記□記號者，為重點檢驗尺寸

		設計DR.	SHLEE	2017.02.08	品名	版本 REV.
		核准	Marco		ARTICLE	A
		容許公差 TOLERANCE			RFDPA131000SBUB802	
		6以下.....±0.2			單位 UNIT	
		6以上~30.....±0.5			比例 SCALE	
		30以上~120.....±0.8			張數 SHEET	
		120以上~315.....±1.2			mm	
		315以上~1000.....±2.0			****	
		1000以上~2000.....±3.0			1	
					☉	

Test Report

■ EXPERIMENTAL SETUP

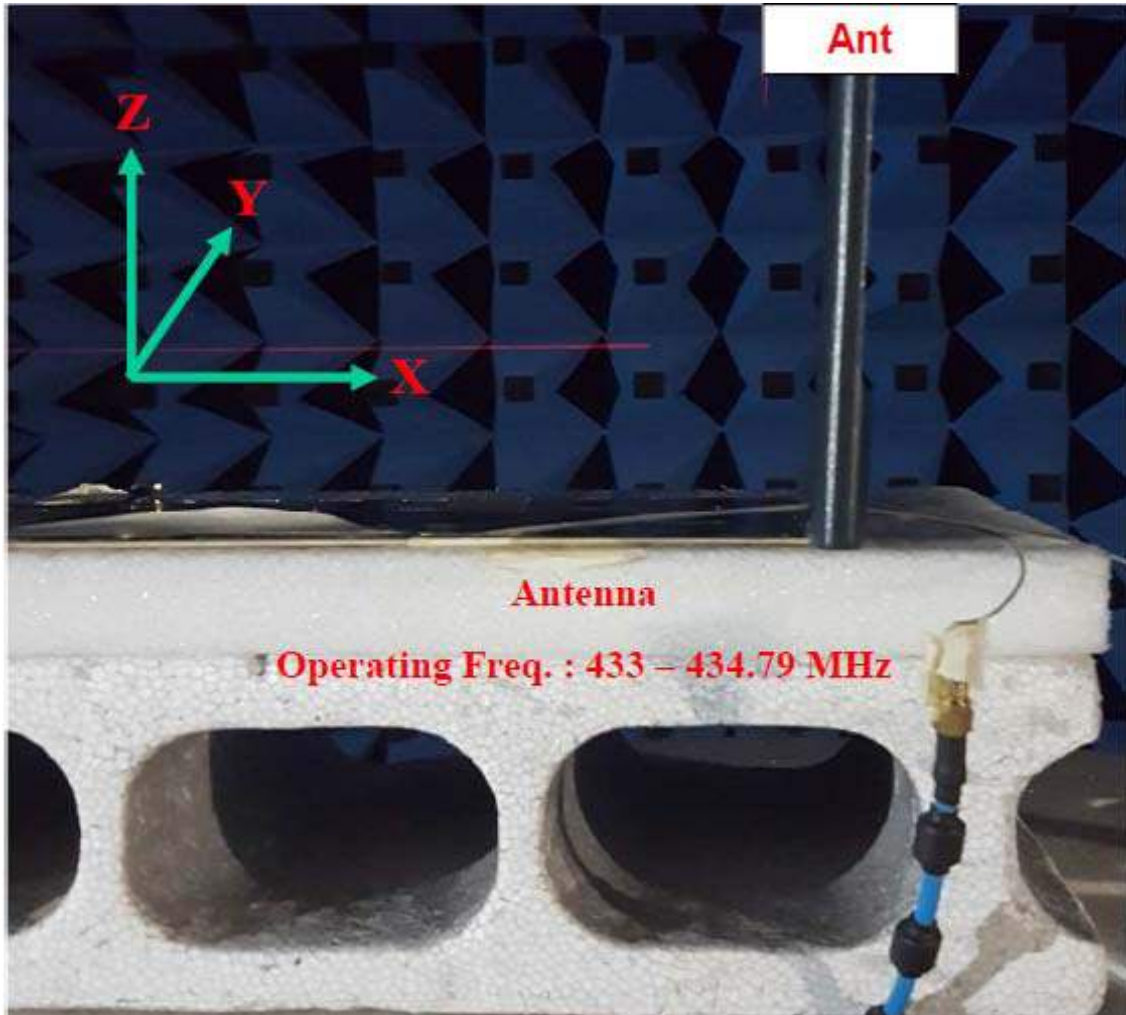

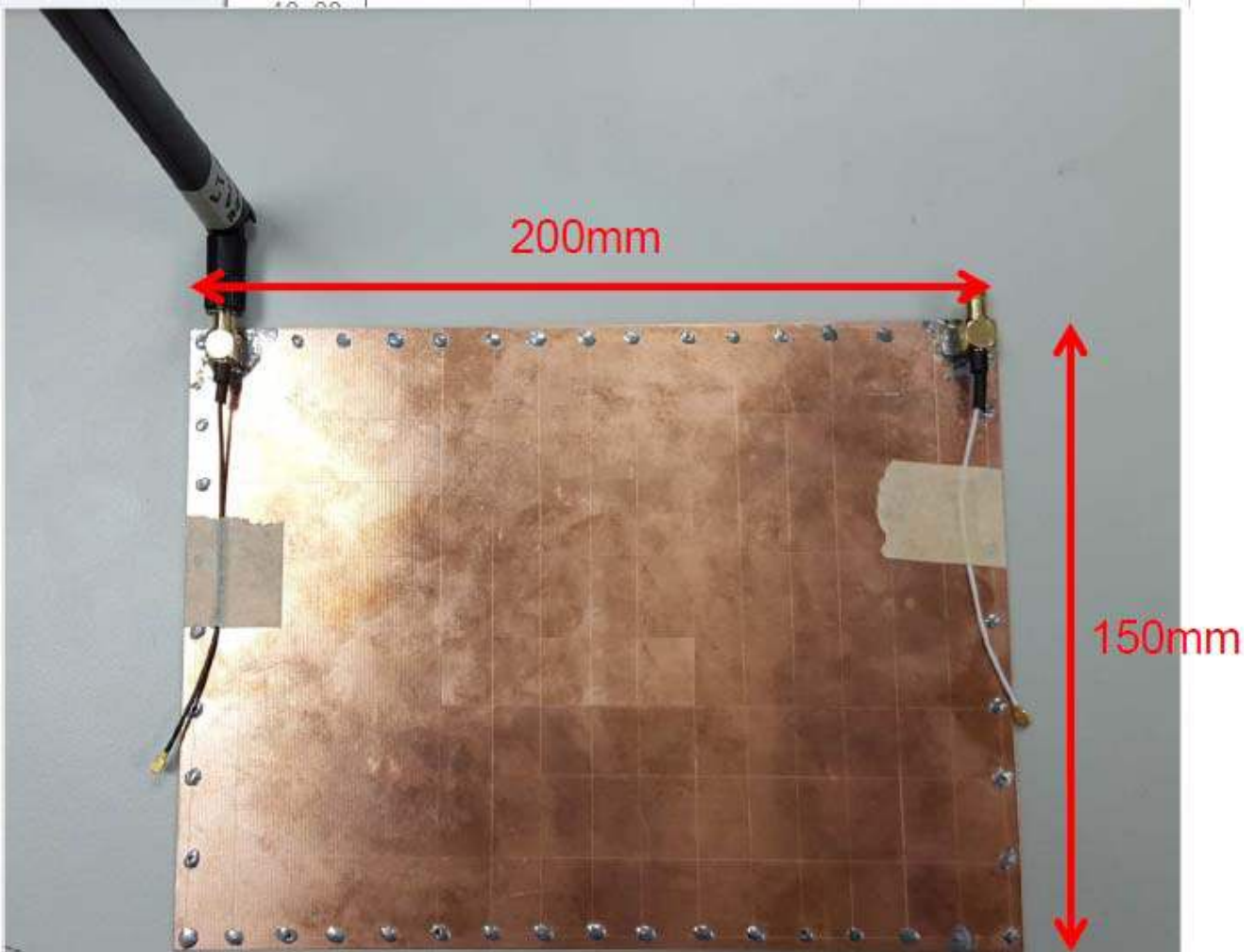

ELECTRICAL CHARACTERISTICS

VSWR

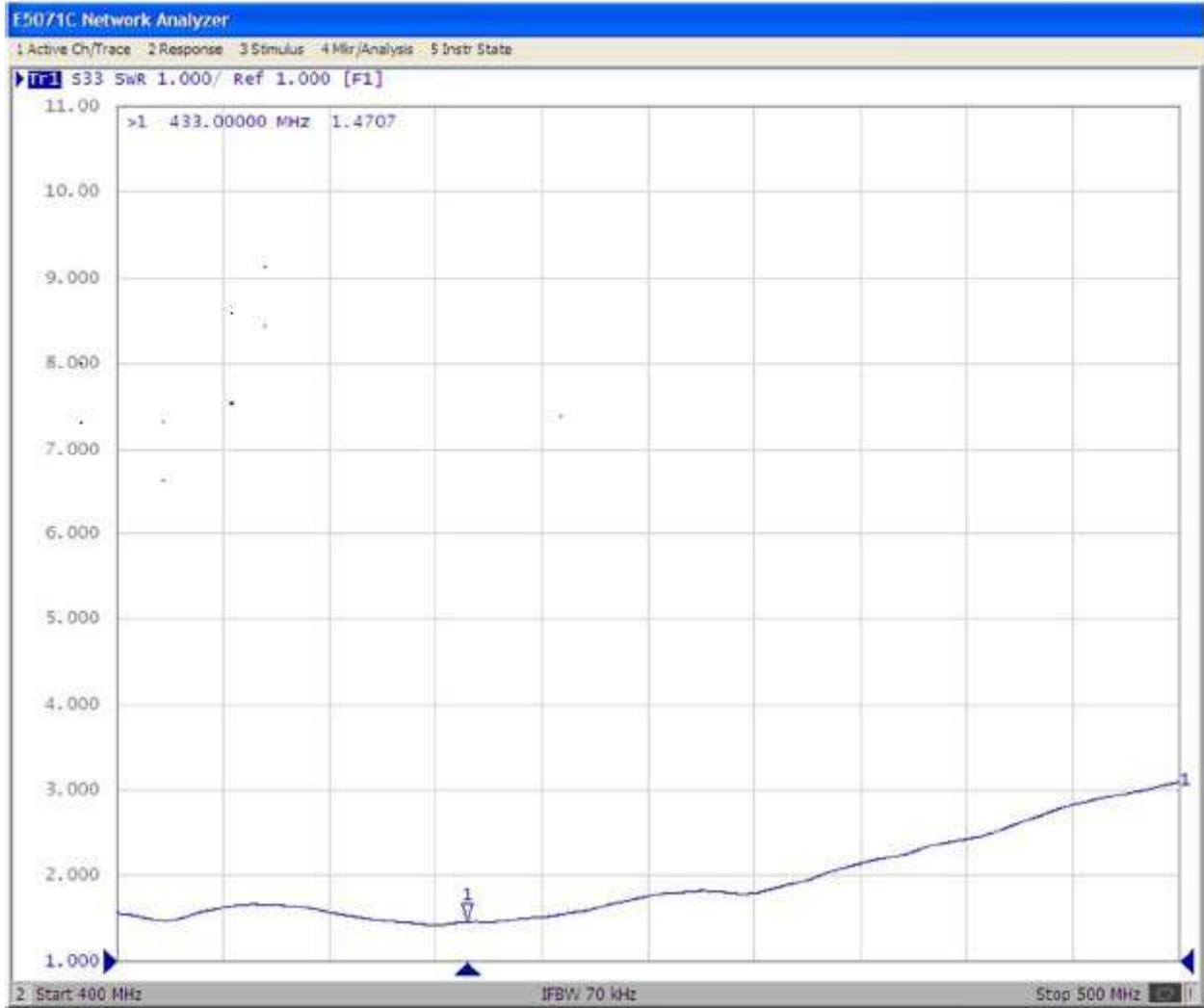

■ Antenna and Peak Gain 433MHz

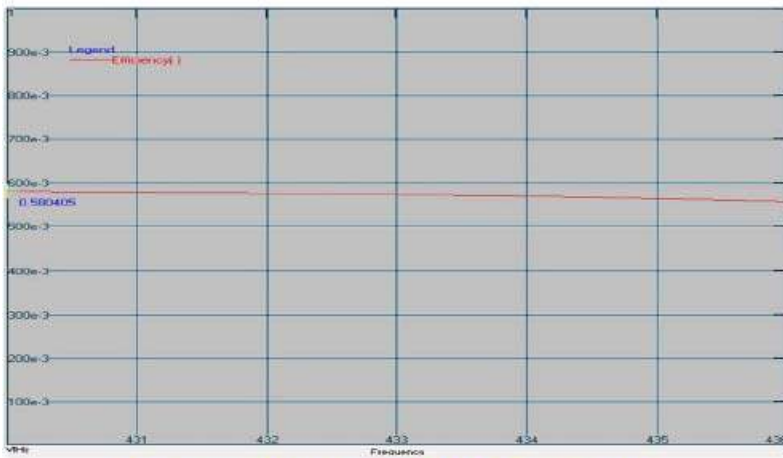
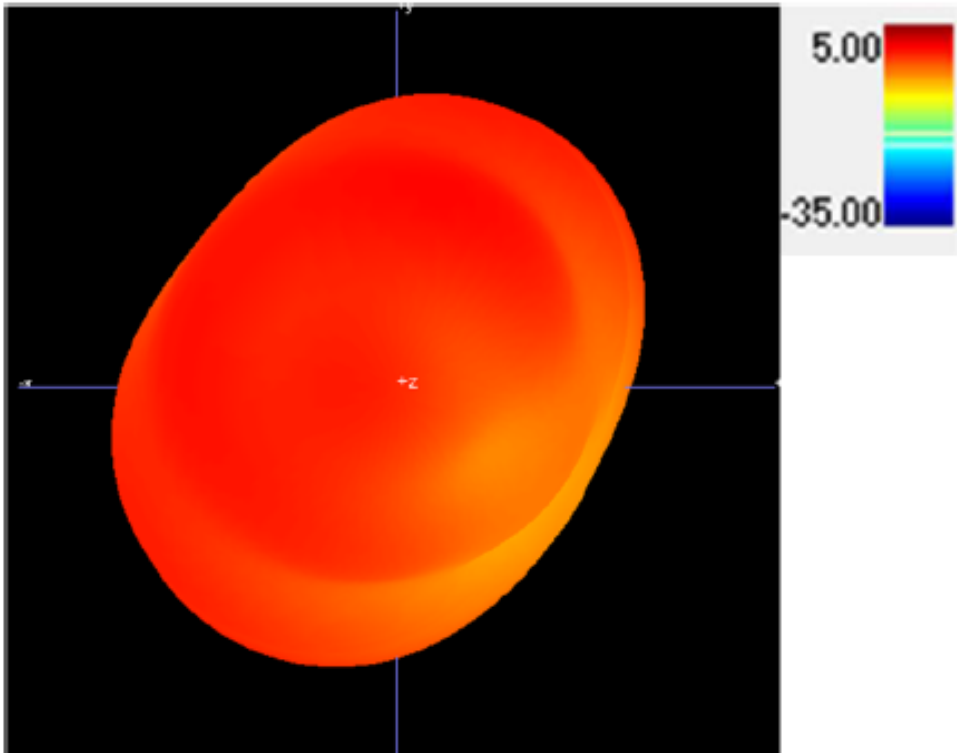

Maximum Efficiency 433MHZ : 57.04 %

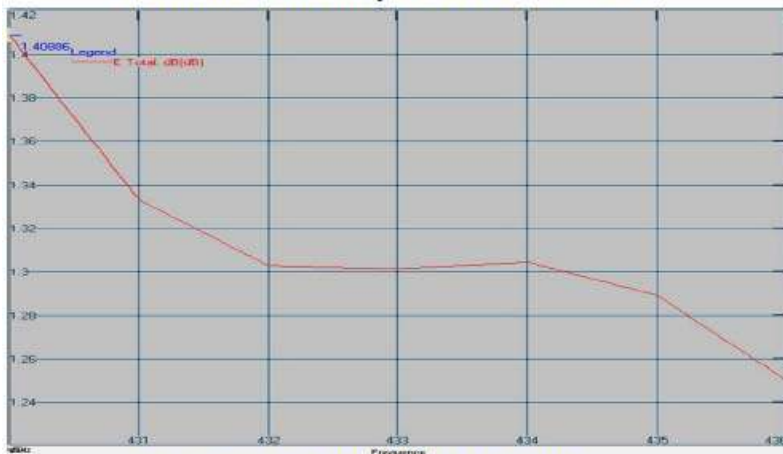

Peak Gain at 433MHZ : 1.3 dBi

RADIATION PATTERN

433 MHz

Phi=0.00deg

Gain . dB

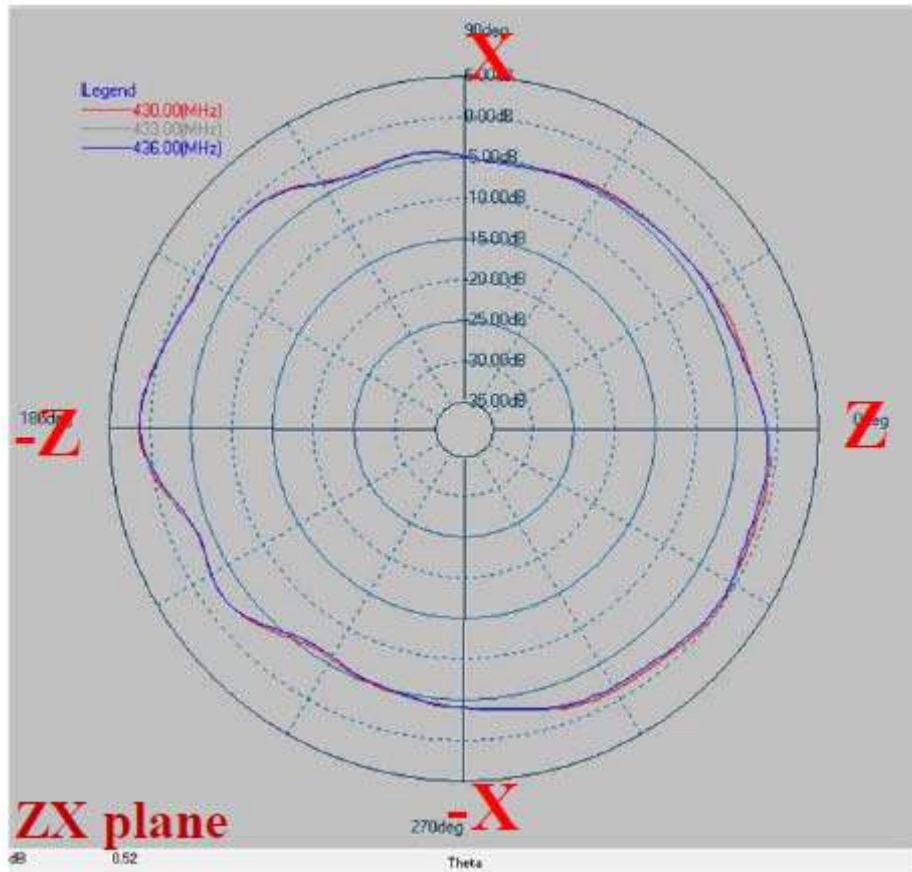

Phi=90.00deg

Gain . dB

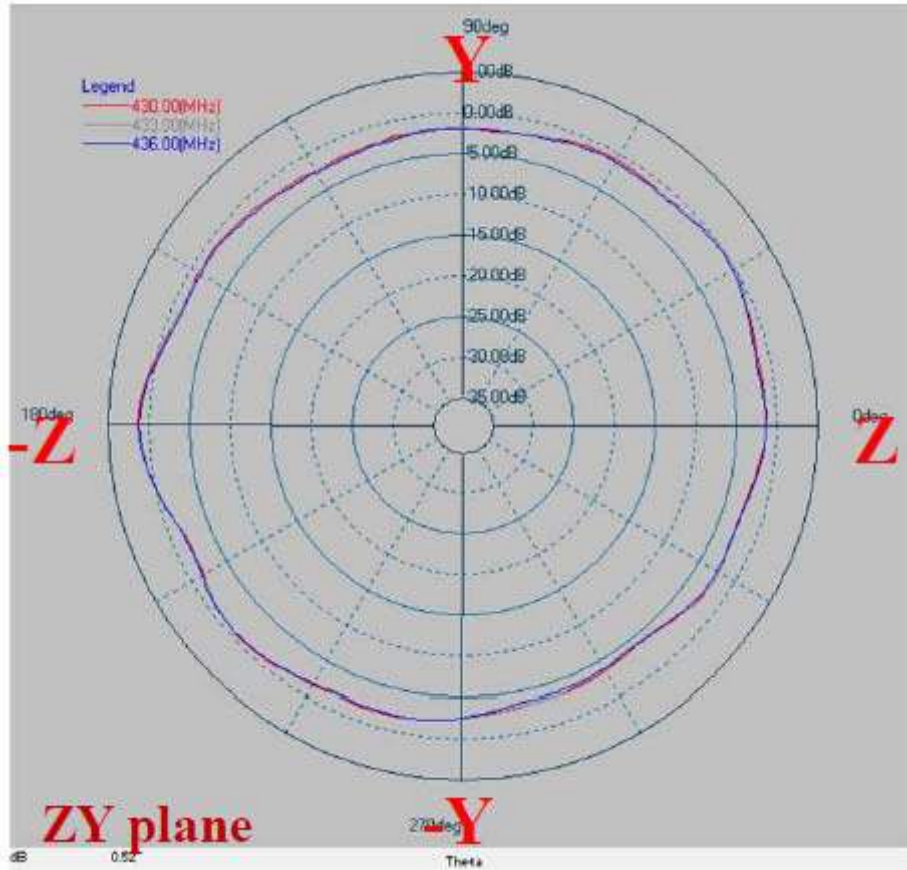

Theta=90.00deg

Gain . dB

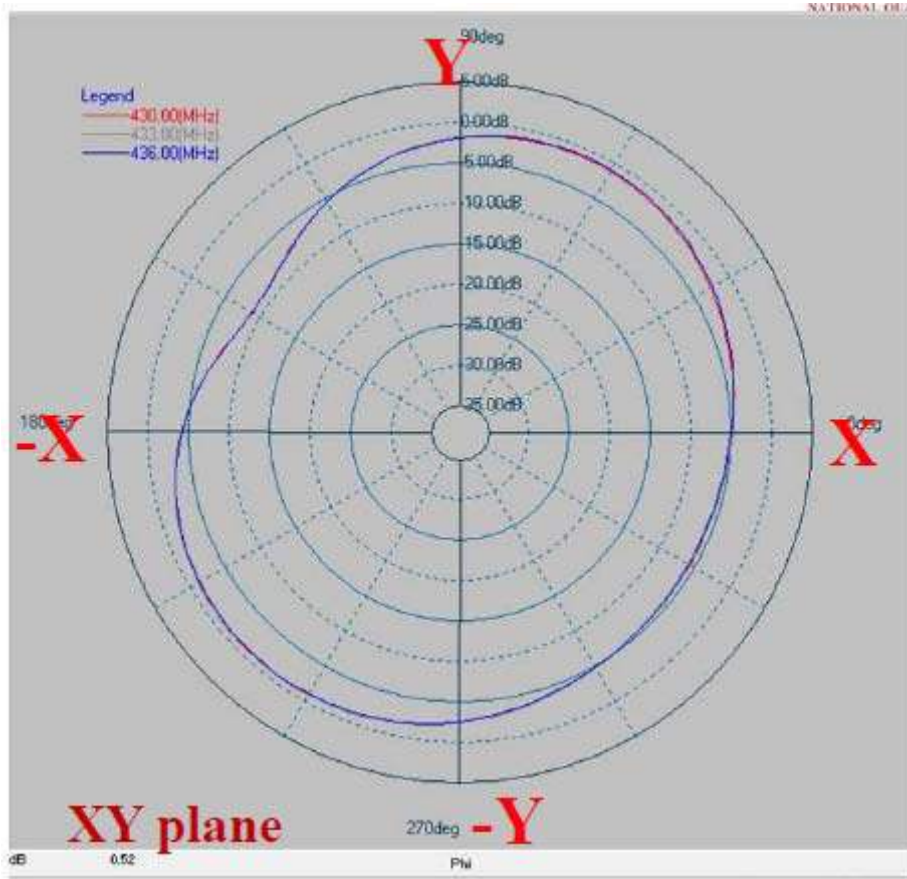

Frequency [MHz]	ZX plane		ZY plane		XY plane	
	Max Value [dB]	Average [dB]	Max Value [dB]	Average [dB]	Max Value [dB]	Average [dB]
430	1.39 dB	-2.24 dB	1.39 dB	-1.47 dB	-0.93 dB	-3.25 dB
433	1.30 dB	-2.31 dB	1.28 dB	-1.52 dB	-0.82 dB	-3.15 dB
436	1.24 dB	-2.45 dB	1.22 dB	-1.63 dB	-1.00 dB	-3.25 dB