

Tous droits strictement réservés. Reproduction ou communication à des tiers interdite sous quelque forme que ce soit sans autorisation écrite du propriétaire. Propriété de © FCI ELECTRONICS. Droits de reproduction FCI ELECTRONICS INC.

All rights strictly reserved. Reproduction or issue to third parties in any form whatever is not permitted without written authority from the proprietor. Copyright © FCI ELECTRONICS INC. Property of © FCI ELECTRONICS

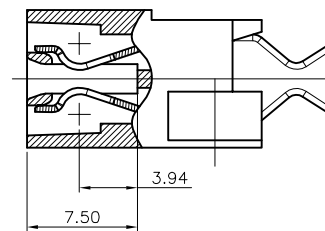

PRODUCT NO.
10034908-001
10034908-001LF

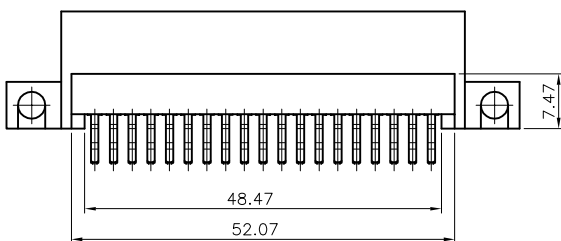
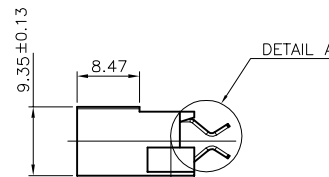
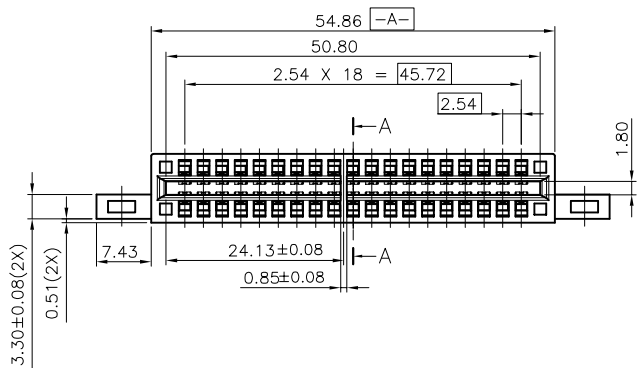
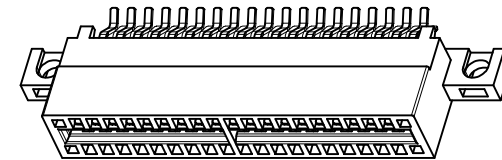
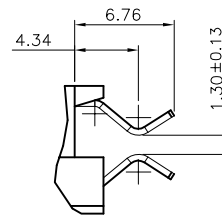
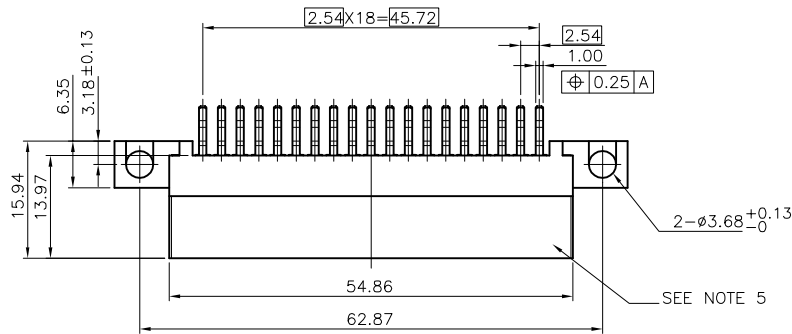

NOTE:

- MATERIAL:
HOUSING: HIGH TEMPERATURE THERMOPLASTIC, UL 94 V-0 FLAME RETARDANT, BLACK.
TERMINAL: HIGH CONDUCTIVITY COPPER ALLOY.
- PLATING: CONTACT AREA: Au 30u" OVER Ni 50u" UNDERPLATED.
SOLDER TAIL: 100u" MATTE PURE TIN OVER Ni 50u" UNDERPLATED.
PART NUMBER 10034908-001LF MEETS EUROPEAN UNION DIRECTIVE AND OTHER COUNTRY REGULATIONS AS DESCRIBED IN GS-22-008; THE HOUSING WILL WITHSTAND EXPOSURE TO 260°C PEAK TEMPERATURE FOR 10 SECONDS IN A REFLOW SOLDER APPLICATION WITH A CIRCUIT BOARD.
- PRODUCT SPECIFICATION: GS-12-279.
- PACKAGING SPEC: GS-14-937.
- MANUFACTURER'S NAME, P/N AND DATE CODE TO APPEAR ON THIS SURFACE AS PER GS-24-007.

mat'l. code				tolerances unless otherwise specified		CUSTOMER COPY		FCI www.fciconnect.com	
ltr	ecn no	dr	date	linear	.X ± 0.8	projection	title		
H	dg06-0306	RYAN	07/30/06		.XX ± 0.25		STRADDLE MOUNT TYPE		
J	dg06-0485	RYAN	11/21/06		.XXX ± 0.13		OF POWER EDGE CONNECTOR		
K	dg06-0524	JULIA	12/26/06	angles	0° ± 2°		product family	PWR EDGE CARD	code
D	dg05-0273	SW	08/09/05	dr	Benny Chen	01/14/04	size	dwg no	—
E	dg05-0287	SW	08/18/05	engr	Benny Chen	01/14/04	scale	5/4	sheet
F	dg05-0339	SW	09/20/05	chr	Paul Wang	01/14/04	1 of 2		
G	dg05-0538	SW	12/13/05	appd	David Su	07/26/04	A3 10034908		
sheet index	revision sheet	K	K						
		1	2						

Tous droits strictement reserves. Reproduction ou communication a des tiers interdite sous quelque forme que ce soit sans autorisation écrite du propriétaire. Propriete de © FCI ELECTRONICS. Droits de reproduction FCI ELECTRONICS INC.

All rights strictly reserved. Reproduction or issue to third parties in any form whatever is not permitted without written authority from the proprietor. Copyright FCI ELECTRONICS INC. Property of © FCI ELECTRONICS

PRODUCT NO.
10034908-001
10034908-001LF

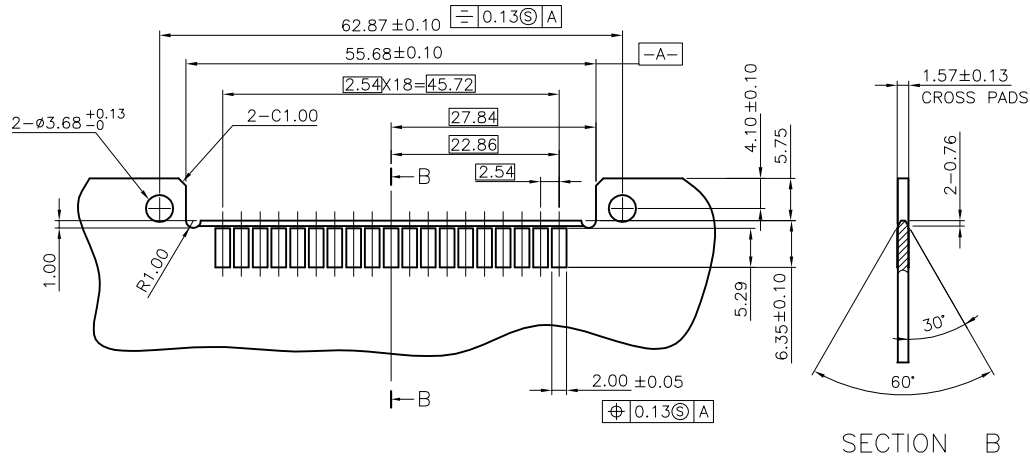

RECOMMENDED PC BOARD LAYOUT FOR CONNECTOR SOLDER TAILS

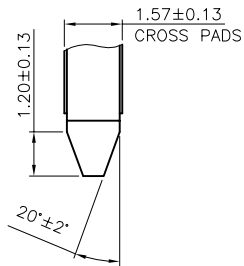

DETAIL D
SCALE 5:1

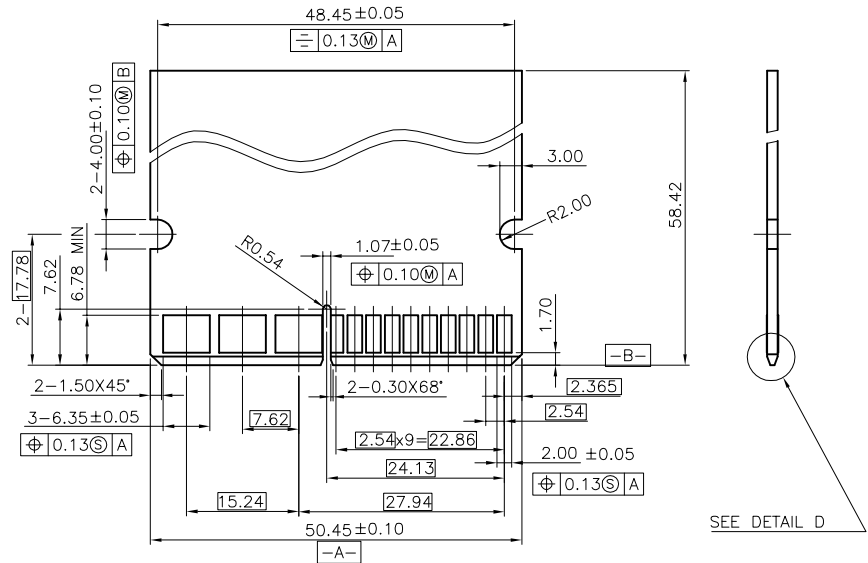

RECOMMENDED MATING BOARD EDGE CONFIGURATION

mat'l. code		tolerances unless otherwise specified		CUSTOMER COPY		FCI www.fciconnect.com	
ltr	ecn no	dr	date	.X ± 0.8	projection	title	
K				linear .XX ± 0.25		STRADDLE MOUNT TYPE OF POWER EDGE CONNECTOR	
				.XXX ± 0.13	0° ± 2°	product family	
				angles		PWR EDGE CARD	
		dr	Benny Chen	01/14/04	mm	code	
		engr	Benny Chen	01/14/04		-	
		chr	Paul Wang	01/14/04	scale	size	
		appd	David Su	07/26/04		10034908	
sheet index	revision sheet				5/4	sheet 2 of 2	